

Ultra-Low Latency (ULL) Networks: A Comprehensive Survey Covering the IEEE TSN Standard and Related ULL Research

Ahmed Nasrallah, Akhilesh Thyagaturu, Ziyad Alharbi, Cuixiang Wang, Xing Shao, Martin Reisslein, and Hesham ElBakoury

Abstract—Many network applications, e.g., industrial control, demand Ultra-Low Latency (ULL). However, traditional packet networks can only reduce the end-to-end latencies to the order of tens of milliseconds. Audio Video Bridging (AVB) standards and IEEE 802.1 Time Sensitive Networking (TSN) standards and related research studies have sought to provide network support for ULL applications. This article provides a comprehensive survey of the existing state-of-the-art techniques for enabling ULL communication across multiple network segments, such as access, backhaul, and core network segments. The purpose of the survey is to provide: i) introduction and tutorial content to understand the fundamentals of ULL communication, ii) identification and classification of the existing state-of-the-art ULL mechanisms, iii) identify the potential pitfalls and challenges, and iv) identify and present future research directions for ULL communication. In particular, we will identify the pitfalls and limitations of existing TSN standards. This survey can then serve as a basis for the development of TSN enhancements to address scenarios and problems that TSN currently cannot address in an adequate manner.

Index Terms—Deterministic networking (DetNet), Preemption, Time-sensitive networking (TSN), Time synchronization, Ultra-low delay.

I. INTRODUCTION

A. Motivation

Traditional networks which provide end-to-end connectivity to the users have only been successful in reducing the operating end-to-end latencies to the order of tens of milliseconds. However, present and future applications demand Ultra-Low Latency (ULL). For instance, the end-to-end latencies should be on the order of a few milliseconds for industrial applications [1], around 1 millisecond for the tactile Internet [2], [3], and on the order of 100 microseconds for the one-way fronthaul in wireless cellular networks.

Please direct correspondence to M. Reisslein.

Supported in part by a gift from Huawei Technologies Co. Ltd.

A. Nasrallah, A. Thyagaturu, Z. Alharbi, and M. Reisslein are with the School of Electrical, Computer, and Energy Eng., Arizona State University, Tempe, AZ 85287-5706, USA, Phone: 480-965-8593, Fax: 480-965-8325, (e-mail: {ahnasral, athyagat, zalharbi, reisslein}@asu.edu).

C. Wang and X. Shao are with the Dept. of Internet of Things Eng., Yancheng Inst. of Techn., Yancheng, Jiangsu Province, P.R. China (e-mail: cwang288@asu.edu, xshao13@asu.edu). C. Wang and X. Shao visited Arizona State Univ., Tempe, while contributing to this study. C. Wang was supported by the Overseas Training Program of the Yancheng Institute of Technology. X. Shao was supported by a Jiangsu Provincial Government Scholarship for Overseas Learning.

H. ElBakoury is with Futurewei Technologies Inc., 2330 Central Expressway, Santa Clara, CA, 95050, USA (e-mail: Hesham.ElBakoury@huawei.com).

For example, critical healthcare applications, e.g., for tele-surgery, and transportation applications [4] require near real-time connectivity. Throughput requirements largely dependent on the application needs, which may widely vary from small amounts of IoT data to large exchanges of media data transfers to and from the cloud (or the fog to reduce latency) [5]. Additionally, autonomous automotive vehicles, augmented and virtual reality (AR/VR), as well as robotic applications which are essential for Industrial IoT (IIoT) may require both high data rates as well as ULL [6], [7]. The high data rates may be required for transporting video feeds from cameras that are used to control vehicles and robots [8]. Therefore, in such heterogeneous environments and applications, a dedicated mechanism to universally accommodate a diverse range of requirements would be very helpful.

B. Contributions and Organization of this Survey

This article provides a comprehensive up-to-date survey of standards and research studies addressing networking mechanisms for ULL applications. Section III covers the IEEE TSN standards that have grown out of the AVB standards and focus primarily on the link layer, while Section IV covers the ULL research studies related to TSN. Section V covers the Internet Engineering Task Force (IETF) Deterministic Networking (DetNet) standards developments, while Section VI covers the ULL research studies related to DetNet.

A large portion of the ULL applications will likely involve wireless communications, whereby the fifth generation (5G) wireless systems will play a prominent role. We therefore survey ULL related standards and research studies for 5G wireless systems in Section VII. Furthermore, many ULL applications will require some support through data centers. We therefore give a brief overview of ULL standards and research directions in the context of data center networks in Section VIII.

Section IX identifies the main gaps and limitation of the existing TSN and DetNet standards and outlines future research directions to address these gaps and limitations.

C. Related Literature

While to the best of our knowledge there is no prior survey on time sensitive networking (TSN), there are prior surveys on topics that relate to TSN. We proceed to review these related surveys and differentiate them from our survey.

A survey on general techniques for reducing latencies in Internet Protocol (IP) packet networks has been presented in [9]. The survey [9] gave a broad overview of the sources of latencies in IP networks and techniques for latency reduction that have appeared in publications up to August 2014. The range of considered latency sources included the network structure, e.g., aspects of content placement and service architectures, the end point interactions, e.g., aspects of transport initialization and secure session initialization, as well as the delays inside end hosts, e.g., operating system delays. In contrast, we provide an up-to-date survey of the IEEE Time Sensitive Networking (TSN) standard for the link layer and the Deterministic Networking (DetNet) standard for the network layer, and related research studies. Thus, in brief, whereas the survey [9] broadly covered all latency sources up to 2014, we comprehensively cover the link and network layer latency reduction standards and studies up to February 2018.

A few surveys have examined specific protocol aspects that relate to latency, e.g., time synchronization protocols have been surveyed in [10], [11], routing protocols have been surveyed in [12]–[14], while congestion control protocols have been covered in [15], [16]. Several surveys have covered latency reduction through mobile edge and fog computing, e.g., see [17]–[20]. Also, the impact of wireless protocols on latency has been covered in a few surveys [21]–[26], while smart grid communication has been covered in [27]. Low-latency coding schemes have been surveyed in [28], [29]. A comprehensive guide to stochastic network calculus, which can be employed to analyze network delays has appeared in [30].

Several surveys have covered the Tactile Internet paradigm [2], [3], [31], [32], which strives for latencies on the order of one millisecond. The AVB standard, which is a predecessor to the IEEE TSN standards development was surveyed in [33], [34]. In contrast to these existing surveys we provide a comprehensive up-to-date survey of the IEEE TSN standards development and the related research studies.

II. BACKGROUND

A. Latency Terminology

Generally, latency refers to the total end-to-end delay of packet from the instant of the beginning of transmission by the sender (talker) to the complete reception by the receiver (listener). The term ultra-low latency (ULL) commonly refers to latencies that are very short, e.g., on the order of a few milliseconds or less than one millisecond. ULL applications often require deterministic latency, i.e., all frames of a given application traffic flow (connection) must have (nearly) the same latency, e.g., for the proper functioning of industrial automation systems. Alternatively, ULL applications may require a deterministically bounded latency, i.e., the frame latencies of a given application traffic flow may vary, but must not exceed a prescribed bound. It is also possible that applications may require probabilistic latency, i.e., a prescribed delay bound should be met with high probability, e.g., for multimedia streaming systems [35], [36], where rare delay bound violations have negligible impact of the perceived quality of the multimedia.

Latency jitter, or jitter for short, refers to the packet latency variations. Often ULL systems require very low jitter. Latency and jitter are two main quality of service (QoS) metrics for ULL networking. We note that there are a wide range of ULL applications with vastly different QoS requirements. For instance, some industrial control applications have relatively high delay bounds on the order of tens of milliseconds, but require that the delay bound be deterministically guaranteed. Other applications may have very tight delay bounds, e.g., less than one millisecond, but can tolerate rare deadline violations.

B. IEEE 802.1 Overview

Before we delve into the standardization efforts of the IEEE Time-Sensitive Network (TSN) Task Group (TG), we briefly explain the organizational structure of the IEEE 802.1 Working Group (WG). The 802.1 WG is chartered to develop and maintain standards and recommended practices in the following areas: 1) 802 LAN/MAN architecture, 2) inter-networking among 802 LANs, MANs, and other wide area networks, 3) security, 4) 802 overall network management, and 5) protocol layers above the MAC and LLC layers. Currently, there are four active task groups in this WG: 1) Time Sensitive Networking, 2) Security, 3) Data Center Bridging, and 4) OmniRAN.

The main IEEE 802.1 standard that has been continuously revised and updated over the years is IEEE 802.1Q-2014 [37], formally known as the IEEE 802.1D standard. That is, IEEE 802.1Q-2014, which we abbreviate to IEEE 802.1Q, is the main Bridges and Bridged Networks standard that incorporated all 802.1Qxx amendments, where “xx” indicates the amendment to the previous version of 802.1Q.

1) *IEEE 802.1 Bridge*: IEEE 802.1Q extensively utilizes the terminology “IEEE 802.1 bridge”, which we abbreviate to “bridge”. A bridge is defined as any network entity within an 802.1 enabled network that conforms to the mandatory or optional/recommended specifications outlined in the standard, i.e., any network node that supports the IEEE 802.1Q functionalities. IEEE 802.1Q details specifications for VLAN-aware bridges and bridged LAN networks. More specifically, IEEE 802.1Q specifies the architectures and protocols for the communications between interconnected bridges (L2 nodes), and the inter-process communication between the layers and sublayers adjacent to the main 802.1 layer (L2).

2) *802.1Q Traffic Classes*: The IEEE 802.1Q standard specifies traffic classes with corresponding priority values that characterize the traffic class-based forwarding behavior, i.e., the Class of Service (CoS) [37, Annex I]. Eight traffic classes are specified in the 802.1Q standard, whereby the priority level ranges from lowest priority (0) to highest priority (7), as summarized in Table II-B2.

C. General Development Steps from Ethernet Towards TSN

Ethernet has been widely adopted as a common mode of networking connectivity due to very simple connection mechanisms and protocol operations. Since its inception in the 1970s [38], [39] and first standardization in the IEEE 802.3 standard in 1983, Ethernet has kept up with the “speed

TABLE I
IEEE 802.1 TRAFFIC CLASSES

Priority	Traffic Class
0	Background
1	Best effort
2	Excellent effort
3	Critical application
4	“Video” < 100 ms latency and jitter
5	“Voice” < 10 ms latency and jitter
6	Internetwork control, e.g., OSPF, RIP
7	Control Data Traffic (CDT), e.g., from IACs

race” and today’s Ethernet definitions support connections up to 400 Gbps. Due to the ever increasing demands, there is an ongoing effort to advance Ethernet connectivity technologies to reach speeds up to 1 Tbps. The best-effort Ethernet service reduces the network complexity and keeps protocol operations simple, while driving down the product costs of Ethernet units. Despite the enormous successes and widespread adoption of Ethernet, the Ethernet definitions fundamentally lack deterministic quality of service (QoS) properties of end-to-end flows. Prior to the development of the TSN standards, ULL applications, e.g., industrial communications, deployed point-to-point communication and circuit switching or specialized/semi-proprietary specifications, such as, fieldbus communication, e.g., IEEE 1394 (FireWire), Process Field Network (Profinet), or Ethernet for Controlled Automation Technology (EtherCAT). In general, the Ethernet definitions lack the following aspects for supporting ULL applications:

- i) Lack of QoS mechanisms to deliver packets in real time for demanding applications, such as real time audio and video delivery.
- ii) Lack of global timing information and synchronization in network elements.
- iii) Lack of network management mechanisms, such as bandwidth reservation mechanisms.
- iv) Lack of policy enforcement mechanisms, such as packet filtering to ensure a guaranteed QoS level for an end-user.

Motivated by these Ethernet shortcomings, the Institute of Electronics and Electrical Engineers (IEEE) and the Internet Engineering Task Force (IETF) have proposed new definitions to introduce deterministic network packet flow concepts. The IEEE has pursued the Time Sensitive Networking (TSN) standardization focusing mainly on physical layer (layer one, L1) and link layer (layer two, L2) techniques within the TSN task group in the IEEE 802.1 working group (WG). The IETF has formed the DEterministic NETwork (DETNET) working group focusing on the network layer (L3) and higher layer techniques.

D. Standards v. Research Studies

In the TSN area, standards have typically preceded research studies, and accordingly, we first survey TSN standards in Section III followed by TSN related research studies in Section IV. This sequence of first standards followed by published research studies may seem counterintuitive as one would think that research studies would be very useful for informing standards.

However, the standardization process is primarily governed by industry. Standardization bodies, such as the IEEE 802.1

WG, the IETF, and the 3GPP, consisting typically of representatives of industry members. A standardization body typically approves a task group (TG) proposal from a small set of members based on current application demands and future needs. An approved TG is commissioned to study and submit a draft consisting of procedures that can meet the requirements. The draft is finalized based on votes from member representatives and will then progress to a standard that is published. Many of the procedures in standards are based on the patents of member companies so that the company that sponsored the standards activity can reap the benefits from licensing its patents. Therefore, all membership companies race to innovate, file patents, and push the patented innovations to standardization. Academic researchers then typically pick up on the standards and conduct and publish research studies on the standardized mechanisms and frameworks.

III. IEEE TSN STANDARDIZATION

This section surveys the standardization efforts of the IEEE 802.1 TSN TG. IEEE 802.1 TSN TG standards and protocols extend the traditional Ethernet data-link layer standards to guarantee data transmission with bounded ultra-low latency, low delay variation (jitter), and extremely low loss, which is ideal for industrial control and automotive applications. TSN can be deployed over Ethernet to achieve the infrastructure and protocol capabilities for supporting real-time Industrial Automation and Control System (IACS) applications.

In order to give a comprehensive survey of the current state of the art of TSN standardization, we categorize the standardization efforts for the network infrastructure supporting ULL applications. We have adopted a classification centered around the notion of the TSN flow defined as follows. An end-to-end unicast or multicast network connection from one end station (talker, sender) to another end station(s) (listener(s), receiver(s)) through the time-sensitive capable network is defined as a *TSN flow*, which we often abbreviate to “flow” and some publications refer to as “stream”. We have organized our survey of the standardized TSN mechanisms and principles in terms of the TSN flow properties, as illustrated in Fig.1. Complementarily to the taxonomy in Fig.1, Fig. 2 provides a historical perspective of the TSN standards and the ongoing derivatives and revisions.

A. Flow Concept

A TSN flow (data link flow) is characterized by the QoS properties (e.g., bandwidth and latency) defined for the traffic class to which the flow belongs. In particular, a TSN flow is defined by the priority code point (PCP) field and VLAN ID (VID) within the 802.1Q VLAN tag in the Ethernet header. The PCP field and VID are assigned based on the application associated with the flow. Fig. 3 outlines the general QoS characteristics of the traffic classes related to the Informational Technology (IT) and Operational Technology (OT) domains. Furthermore, Fig. 3 provides the main features for each block, including typical applications used. As IT and OT establish a converged interconnected heterogeneous network, the delay bottleneck must be diminished to tolerable levels for IACS applications, i.e., the machine and control floor networks.

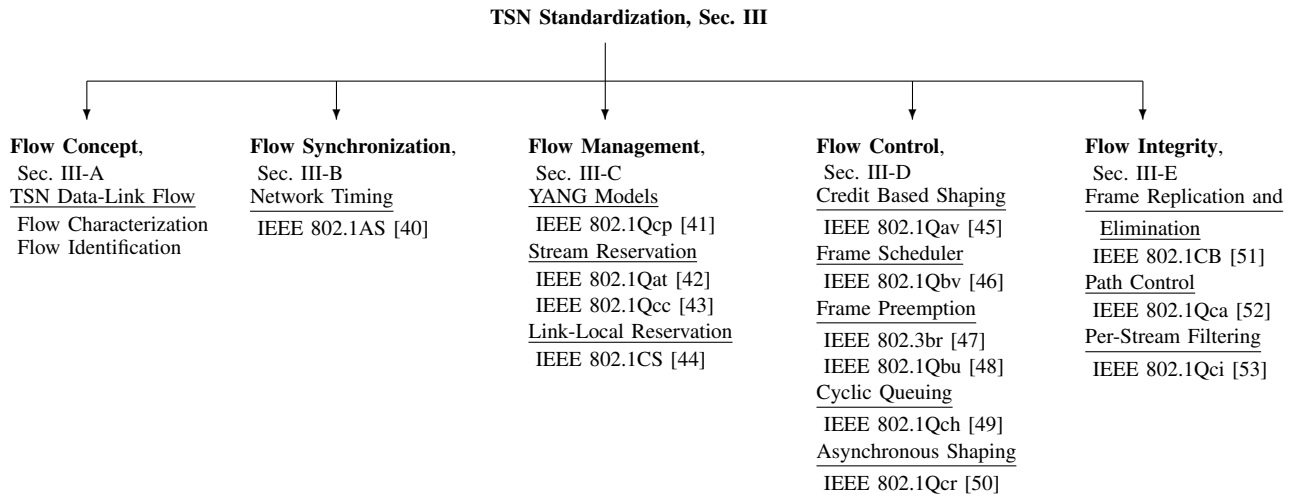

Fig. 1. Classification taxonomy of Time Sensitive Networking (TSN) standardization

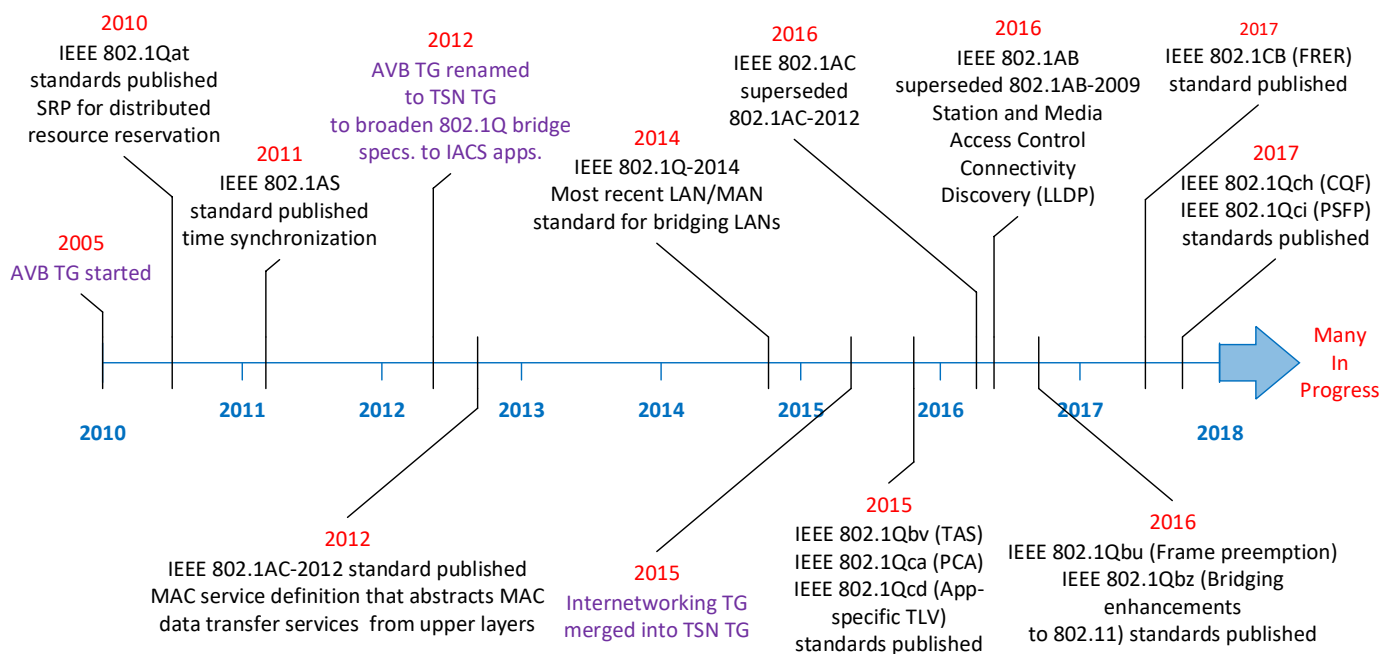

Fig. 2. Timeline of IEEE TSN task group (TG), highlighting significant milestones and depicting the shift from Audio Video Bridging (AVB) to TSN.

1) *Summary and Lessons Learned*: In general, TSN flows are viewed as flows of normal 802.1Q Ethernet frames with a certain priority that gives TSN flow frames more privileges than regular Ethernet non-TSN frames. The key notion is that TSN flow identification must be accurate and clear so as to avoid any mismanagement or errors due to incorrect or confusing flow identification. Furthermore, as opposed to AVB, which focuses more on reliable, jitter-free flows, TSN, in addition to AVB properties, focuses on frame transmission time, frame preemption, and path redundancy.

B. Flow Synchronization

1) *IEEE 802.1AS Time Synchronization for Time-Sensitive Applications*: Many TSN standards are based on a network-wide precise time synchronization, i.e., an established common time reference that is shared by all TSN network entities. The time synchronization is for instance employed to determine op-

portune data and control signaling scheduling. Time synchronization is accomplished through the IEEE 802.1AS standalone standard, which uses a specialized profile (selection of features/configuration) of IEEE 1588-2008 (1588v2) [54], the generic Precision Time Protocol (gPTP), to synchronize clocks between network devices [10], [40]. This time-aware network, also referred to as gPTP domain, as illustrated in Fig. 4, synchronizes time by passing relevant time event messages between the Clock Master (CM) and the Clock Slaves (CSs). The time-aware network utilizes the peer-path delay mechanism to compute both the residence time, i.e., the ingress-to-egress processing, queuing, and transmission time within a bridge, and the link latency, i.e., the single hop propagation delay between adjacent bridges within the time-aware network hierarchy with reference to the GrandMaster clock at the root of the hierarchy [40, Section 11]. The GM clock is defined as the bridge with the most accurate clock

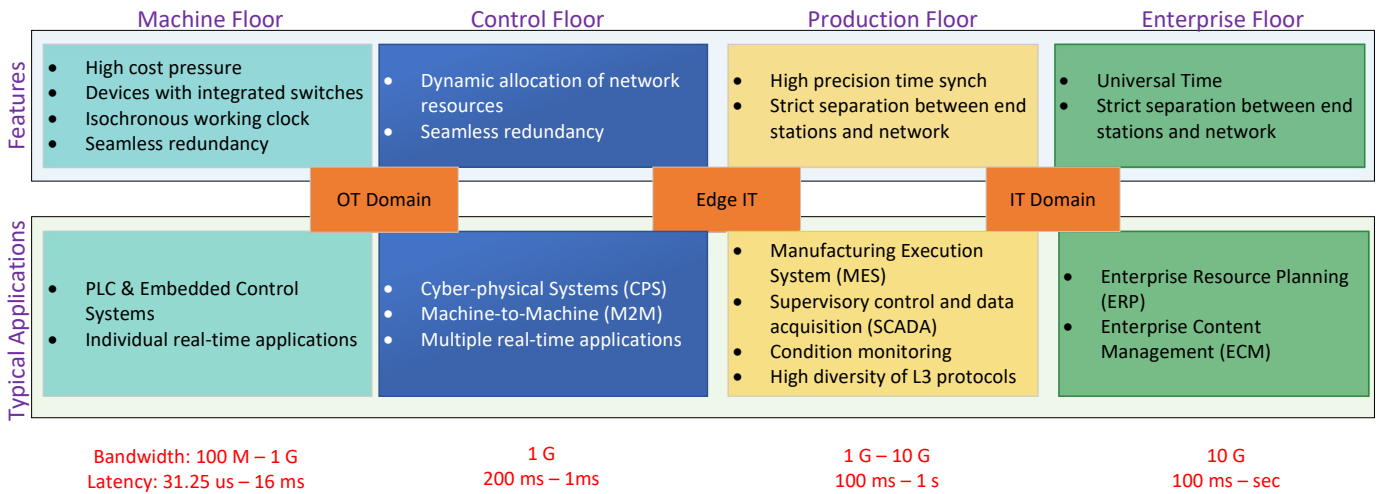

Fig. 3. Illustration of the broad range of QoS requirements according to the network setting (floor), where the machine floor requires the highest level of determinism and lowest latency. Traditional networking is deployed on the enterprise floor. The top row summarizes the features required at each floor, while the bottom row illustrates typical example applications. TSN can, in principle, be deployed everywhere, but typically, TSN is most attractive for the real-time systems in the OT Domain, i.e., the machine and control floors.

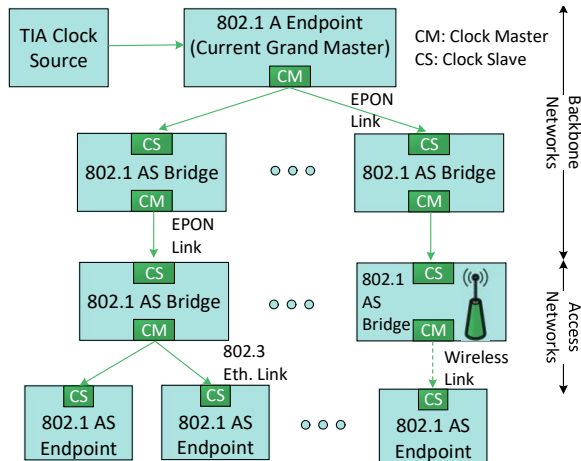

Fig. 4. Illustration of a typical gPTP domain operation and time sharing where the selected GM source distributes timing information to all downstream 802.1AS bridges. Each bridge corrects the delay and propagates the timing information on all downstream ports, eventually reaching the 802.1AS end points (end stations). The International Atomic Time (TIA) is the GM's source for timing information.

source selected by the BMCA algorithm [54].

For example, in Fig. 4, the bottom left-most 802.1AS end point receives time information from the upstream CM which includes the cumulative time from the GM to the upstream CM. For full-duplex Ethernet LANs, the path delay measurement between the local CS and the direct CM peer is calculated and used to correct the received time. Upon adjusting (correcting) the received time, the local clock should be synchronized to the gPTP domain's GM clock.

In general, gPTP systems consist of distributed and interconnected gPTP and non-gPTP devices. gPTP devices can either be a time-aware bridge or end point, while non-gPTP devices include any passive or active device that does not contribute to time synchronization in the distributed network. gPTP is a distributed protocol that uses a master-slave architecture

to synchronize real-time clocks in all devices in the gPTP domain with the root reference (GM) clock. Synchronization is accomplished through a two-phase process: The gPTP devices 1) establish a master-slave hierarchy, and 2) apply clock synchronization operations. In particular, gPTP establishes a master-slave hierarchy using the Best Master Clock Algorithm (BMCA) [54], which is split into two separate algorithms, namely data set comparison and state decision. Each gPTP device stores a gPTP engine, i.e., a gPTP state machine, and employs several gPTP UDP IPv4 or IPv6 multicast and unicast messages to establish the appropriate hierarchy and to correctly synchronize time [40]. Note that any non-time aware bridge cannot relay or synchronize timing messages and hence does not participate in the BMCA clock spanning tree protocol.

The time synchronization accuracy depends mainly on the accuracy of the residence time and link delay measurements. In order to achieve high accuracy, 802.1AS time-aware systems correct the received upstream neighbor master clock's timing information through the GM's frequency ratio, this process is called logical synchronization in the standard. In the synchronization context, frequency refers to the clock oscillator frequency. The frequency ratio is the ratio of the local clock frequency to the frequency of the time-aware system at the other end of an attached link. 802.1AS achieves proper synchronization between time-aware bridges and end systems using both the frequency ratio of the GM relative to the local clock to compute the synchronized time, and the frequency ratio of the neighbor CM relative to the local CS to correct any propagation time measurements.

IEEE802.1AS-REV introduces new features needed for time-sensitive applications. These features include the ability to support multiple time domains to allow rapid switchover should a GM clock fail, and improved time measurement accuracy.

2) *Summary and Lessons Learned*: IEEE 802.1AS provides reliable accurate network wide time synchronization.

All gPTP systems compute both the residence time and the link latency (propagation delay) and exchange messages along a hierarchical structure centered around the selected GM clock to accurately synchronize time. Flow control and management components, e.g., IEEE 802.1Qbv and 802.1Qcc (see Sections III-D and III-C), can utilize the 802.1AS timing synchronization to provide accurate bounded latency and extremely low loss and delay variation for TSN applications.

An open aspect of time synchronization is that the frequent periodic exchange of timing information between the individual network entities can stress and induce backpressure on the control plane. The control plane load due to the time synchronization can ultimately impact ULL applications. A centralized time synchronization system, e.g., based on a design similar to SDN, with message exchanges only between a central synchronization controller and individual network entities could help mitigate control plane overhead. However, such a centralized synchronization approach may create a single-point of failure on the time synchronization process. The detailed quantitative study of these trade-offs is an interesting direction for future research.

C. Flow Management

Flow management enables users or operators to dynamically discover, configure, monitor, and report bridge and end station capabilities.

1) *IEEE 802.1Qcp YANG Data Model*: The TSN TG has proposed the IEEE 802.1Qcp TSN Configuration YANG model standard to achieve a truly universal Plug-and-Play (uPnP) model. The IEEE 802.1Qcp standard utilizes the Unified Modeling Language (UML), specifically the YANG [55], [56] data model. The YANG data model provides a framework for periodic status reporting as well as for configuring 802.1 bridges and bridge components, including Media Access Control (MAC) Bridges, Two-Port MAC Relays (TPMRs), Customer Virtual Local Area Network (VLAN) Bridges, and Provider Bridges [41]. Additionally, IEEE 802.1Qcp is used to support other TSN standard specifications, such as the Security and Datacenter Bridging TG standards 802.1AX and 802.1X.

YANG [55], [56] is a data modeling language for configuration data, state data, remote procedure calls, and notifications for network management protocols, e.g., NETCONF and RESTCONF. NETCONF is the Network Configuration Protocol [57] that provides mechanisms to install, manage, and delete the configurations of network devices. The industry wide adoption of the YANG formalized data modeling language, e.g., by the IETF and the Metro Ethernet Forum (MEF), is an important motivation for integrating, automating, and providing support for YANG data modeling in 802.1 bridges and related services for upper layer components.

2) *IEEE 802.1Qat Stream Reservation Protocol (SRP) and IEEE 802.1Qcc Enhancements to SRP and Centralization Management*: The IEEE 802.1Qat Stream Reservation Protocol (SRP) [42], which has been merged into 802.1Q, provides a fundamental part of TSN. In particular, IEEE 802.1Qat specifies the admission control framework for reserving network resources and advertising streams in packet switched networks

over full-duplex Ethernet links. Most of the standards that use priorities, frame scheduling, and traffic shaping protocols depend on SRP [42], since these protocols work correctly only if the network resources are available along the entire path from the sender (talker) to the receivers (listeners). IEEE 802.1Qat is a distributed protocol that was introduced by the AVB TG to ensure that the AVB talker is guaranteed adequate network resources along its transmission path to the listener(s). This is accomplished using the Multiple Registration Protocol (MRP) [37, Section 10], where the traffic streams are identified and registered using a 48-bit Extended Unique Identifier (EUI-48). The EUI-48 is usually the MAC source address concatenated with a 16-bit handle to differentiate different streams from the same source and is also referred to as *StreamID*. The SRP reserves resources for a stream based on the bandwidth requirement and the latency traffic class using three signaling protocols, namely 1) the Multiple MAC Registration Protocol (MMRP), 2) the Multiple VLAN Registration Protocol (MVRP), and 3) the Multiple Stream Registration Protocol (MSRP) [37], [42, Section 35].

MMRP and MVRP control the group registration propagation and the VLAN membership (MAC address information [37, Sections 10 and 11]), while MSRP conducts the distributed network resource reservation across bridges and end stations. MSRP registers and advertises data stream characteristics and reserves bridge resources to provide the appropriate QoS guarantees according to the talker's declared propagation attributes, which include the SRP parameters that are sent by the end station in MSRP PDUs (MSRPDUs). A station (talker) sends a reservation request with the MRP, i.e., the general MRP application which registers the stream resource reservation. The 802.1 TSN TG has developed the MRP Attribute Declaration (MAD) for describing the request based on the stream's characteristics. All participants in the stream have an MSRP application and MAD specification and each bridge within the same SRP domain can map, allocate, and forward the stream with the necessary resources using the MRP attribute propagation (MAP) [42]. Fig. 5 illustrates the MRP architecture.

In essence, the SRP protocol ensures QoS constraints for each stream through the following steps:

- 1) Advertise stream
- 2) Register paths of stream
- 3) Calculate worst-case latency
- 4) Establish an AVB domain
- 5) Reserve the bandwidth for the stream

Since the existing IEEE 802.1Qat (802.1Q Section 35) SRP features a decentralized registration and reservation procedure, any changes or new requests for registrations or de-registrations can overwhelm the network and result in intolerable delays for critical traffic classes. Therefore, the TSN TG has introduced the IEEE 802.1Qcc standard to improve the existing SRP by reducing the size and frequency of reservation messages, i.e., relaxing timers so that update are only triggered by link state or reservation changes.

Additionally, IEEE 802.1Qcc [43] provides a set of tools to manage and control the network globally. In particular, IEEE 802.1Qcc enhances the existing SRP with a User

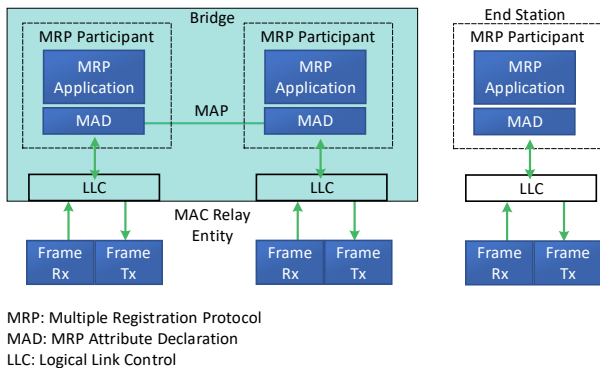

Fig. 5. Illustration of Multiple Registration Protocol (MRP) architecture: Each end station (illustrated on the right) declares the propagation attributes using the MRP Attribute declaration (MAD) and the MRP Applications encapsulated as an MRP participant which gives end stations the ability to register resources. The MRP participant entry is stored in bridges and mapped between all the required ports using MRP Attribute Propagation (MAP). A bridge mapping between two different interfaces in the LAN is illustrated on the left.

Network Interface (UNI) which is supplemented by a Centralized Network Configuration (CNC) node, as shown in Fig. 6. The UNI provides a common method of requesting layer 2 services. Furthermore, the CNC interacts with the UNI to provide a centralized means for performing resource reservation, scheduling, and other types of configuration via a remote management protocol, such as NETCONF [57] or RESTCONF [58]; hence, 802.1Qcc is compatible with the IETF YANG/NETCONF data modeling language.

For a fully centralized network, an optional Centralized User Configuration (CUC) node communicates with the CNC via a standard Application Programming Interface (API), and can be used to discover end stations, retrieve end station capabilities and user requirements, and configure delay-optimized TSN features in end stations (mainly for closed-loop IACS applications). The interactions with higher level reservation protocols, e.g., RSVP, are seamless, similar to how the AVB Transport Protocol IEEE 1722.1 [59] leverages the existing SRP.

802.1Qcc [43] still supports the fully distributed configuration model of the original SRP protocol, i.e., allows for centrally managed systems to coexist with decentralized ad-hoc systems. In addition, 802.1Qcc supports a “hybrid” configuration model, allowing a migration path for legacy AVB devices. This hybrid configuration management scheme when coupled with IEEE 802.1Qca Path Control and Reservation (PCR) (see Section III-E2) and the TSN shapers can provide deterministic end-to-end delay and zero congestion loss.

3) *IEEE 802.1CS Link-Local Reservation Protocol (LRP)*: To effectively achieve tight bounds on latency and zero congestion loss, traffic streams need to utilize effective admission control policies and secure resource registration mechanisms, such as the SRP [42] and the SRP enhancements and management standard [43]. While the MRP [37, Section 10] provides efficient methods for registering streams; the database holding

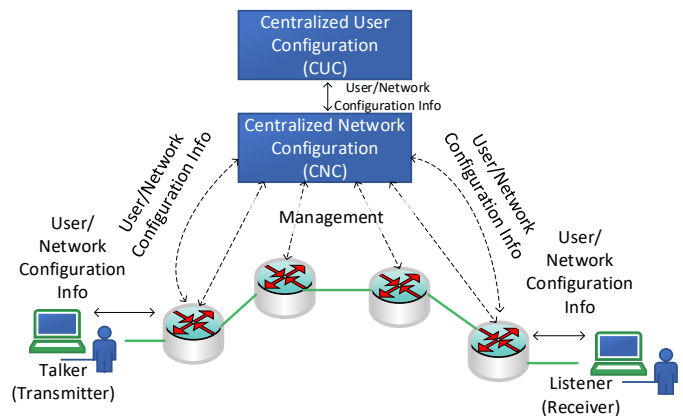

Fig. 6. Illustration of Centralized Network Configuration (CNC): End stations interact with the network entities via the User-Network Interface (UNI). The CNC receives the requests, e.g., flow reservation requests, and provides corresponding management functions. An optional CUC provides delay-optimized configuration, e.g., for closed-loop IACS applications. The solid arrows represent the protocol, e.g., YANG or TLV, that is used as the UNI for exchanging configuration information between Talkers/Listeners (users) and Bridges (network). The dashed arrows represent the protocol, e.g., YANG or TLV, that transfers configuration information between edge bridges and the CNC.

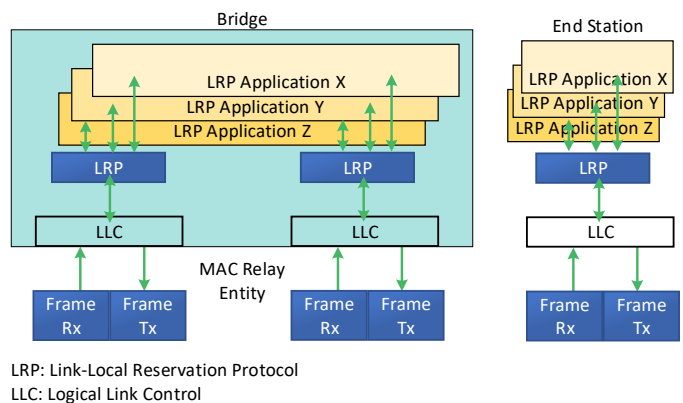

Fig. 7. Illustration of LRP Architecture: A Link-Local Reservation Protocol (LRP) instance (illustrated by the blue LRP box) interacts with each application and provides a generic transport service for multiple registered LRP applications, which are represented by yellow colored boxes near the top of the illustration.

the stream state information, is limited to about 1500 bytes. As more traffic streams coexist and the network scale increases, MRP slows significantly as the database proportionally increases which results in frequent cyclic exchanges through the MAD between all bridge neighbors.

The Link-Local Reservation Protocol (LRP) [44] has been introduced by the 802.1 TSN TG to efficiently replicate an MRP database between two ends of a point-to-point link and to incrementally replicate changes as bridges report new network developments or conditions. Additionally, the LRP provides a purging process that deletes replicated databases when the source of such databases remains unresponsive or the data gets stale. Furthermore, the LRP is optimized to efficiently handle databases on the order of 1 Mbyte.

While MRP is considered application specific, i.e., the MRP operations are defined by each registered application, LRP is an application neutral transport protocol. Fig 7 illustrates

the LRP protocol architecture operating within bridges or end points.

4) *Resource Allocation Protocol (RAP)—Towards a Distributed TSN Control Model:* Although the SRP and the related MSRP (MSRPv1 [43]) were designed for distributed stream configuration (including registration, reservation, and provisioning), SRP is generally restricted to A/V applications with a limited number of Stream Reservation (SR) classes, e.g., classes A and B for the Credit Based Shaper (CBS), see Section III-D1. SRP guarantees the QoS characterized by each stream through the reservation in conjunction with shaper mechanisms, see Section III-D. IEEE 802.1Qcc pushed for more centralized configuration models, where all the newly established TSN features, e.g., shaping, preemption, and redundancy, are supported through the CNC configuration model. Any distributed model is currently restricted to CBS.

The Resource Allocation Protocol (RAP) [60] leverages the LRP to propagate TSN stream configuration frames that include resource reservation and registration information in a manner similar to MSRP. The MSRP (and MSRPv1) is geared towards AVB systems, while RAP is defined for TSN enabled systems for distributed stream configuration. The RAP promises to improve scalability (through LRP), to support all TSN features, to improve performance under high utilization, and to enhance diagnostic capabilities.

5) *Summary and Lessons Learned:* Flow management allows distributed (legacy SRP and RAP) as well as centralized (802.1Qcc and 802.1CS) provisioning and management of network resources, effectively creating protected channels over shared heterogeneous networks. Moreover, flow management offers users and administrators Operations, Administration, Maintenance (OAM) functions to monitor, report, and configure (802.1Qcp and 802.1Qcc) network conditions. This allows for fine-grained support of network services while enforcing long term allocations of network resources with flexible resource control through adaptive and automatic re-configurations.

However, both centralized and distributed flow management models have specific deployment advantages and disadvantages. For example, a centralized entity presents a single point of failure, whereas, distributed schemes incur extensive control plane overhead. A centralized scheme can benefit from SDN implementation and management but could result in new infrastructure cost for the operators. Nevertheless, the choice of deployments can be based on the relative performance levels among centralized and distributed nodes, as well as the use of existing and deploying new infrastructure. Future research needs to thoroughly examine these trade-offs.

Another important future research direction is to examine predictive models that estimate the resource reservation requirements in bridges. Estimations may help in effectively managing queues and scheduling while efficiently utilizing the network resources.

D. Flow Control

Flow control specifies how frames belonging to a prescribed traffic class are handled within TSN enabled bridges.

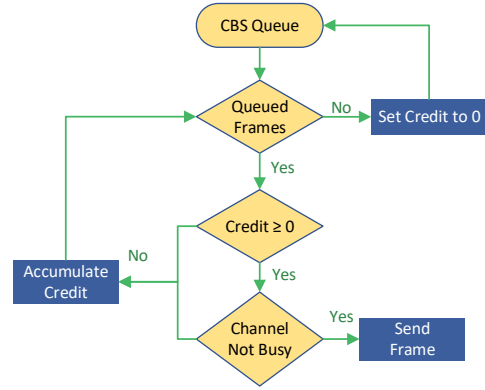

Fig. 8. Flow-chart illustration of the Credit-Based Shaper (CBS) operation for a given queue. A queue is permitted to transmit if both credits are greater than or equal to zero, and the channel is vacant.

1) *IEEE 802.1Qav Forwarding and Queuing of Time-Sensitive Streams:* IEEE 802.1Qav specifies Forwarding and Queuing of Time Sensitive Streams (FQTSS), which has been incorporated into 802.1Q. IEEE 802.1Qav serves as a major enhancement to the forwarding and queuing operation in the traditional Ethernet networks. IEEE 802.1Qav specifies bridge operations that provide guarantees for time-sensitive (i.e., bounded latency and jitter), lossless real-time audio/video (A/V) traffic [45]. The IEEE 802.1Qav standard [37], [45, Section 34], details flow control operations, such as per priority ingress metering and timing-aware queue draining algorithms.

IEEE 802.1Qav was developed to limit the amount of A/V traffic buffering at the downstream receiving bridges and/or end stations. Increasing proportions of bursty multimedia traffic can lead to extensive buffering of multimedia traffic, potentially resulting in buffer overflows and packet drops. Packet drops may trigger retransmissions, which increase delays, rendering the re-transmitted packets obsolete and diminishing the Quality of Experience (QoE).

IEEE 802.1Qav limits the amount of buffering required in the receiving station through the Stream Reservation Protocol (SRP) [42] in conjunction with a credit-based shaper (CBS). The CBS spaces out the A/V frames to reduce bursting and bunching. This spacing out of A/V frames protects best-effort traffic as the maximum AVB stream burst is limited. The spacing out of A/V frames also protects the AVB traffic by limiting the back-to-back AVB stream bursts, which can interfere and cause congestion in the downstream bridge.

The CBS shaper separates a queue into two traffic classes, class A (tighter delay bound) and class B (looser delay bound). Each class queue operates according to the throttling mechanism illustrated in Fig. 8. When no frame is available in the queue, the credit for the queue is set to zero. A queue is eligible for transmission if the credit is non-negative. Credit is increased by *idleSlope* when there is at least one frame in the queue, and decreased by *sendSlope* when a frame is transmitted. The CBS throttles each shaped traffic class to not exceed their preconfigured bandwidth limits (75% of maximum bandwidth due to bandwidth intensive applications, e.g., audio and video). The CBS in combination with the SRP

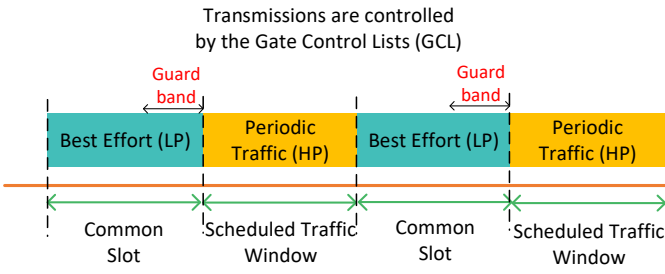

Fig. 9. IEEE 802.1Qbv Time-Aware Shaper (TAS) [46]: Scheduled traffic is sent over synchronized Time-Division Multiplexing “windows” within the Ethernet traffic. Yellow marked frames are time-sensitive traffic that have guaranteed reserved resources across the network, while the blue frames correspond to best-effort low priority (LP) traffic.

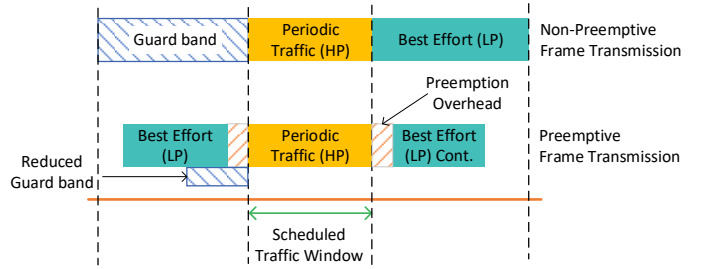

Fig. 11. The IEEE 802.1Qbv transmission selection prevents low priority (best effort) frames from starting transmission if the transmission cannot be completed by the start of the scheduled traffic window. This transmission selection essentially enforces a guard band (sized as a maximum size frame) to protect the scheduled traffic window. With preemption (IEEE 802.3br, IEEE 802.1Qbu) the guard band can be reduced to the smallest Ethernet frame fragment.

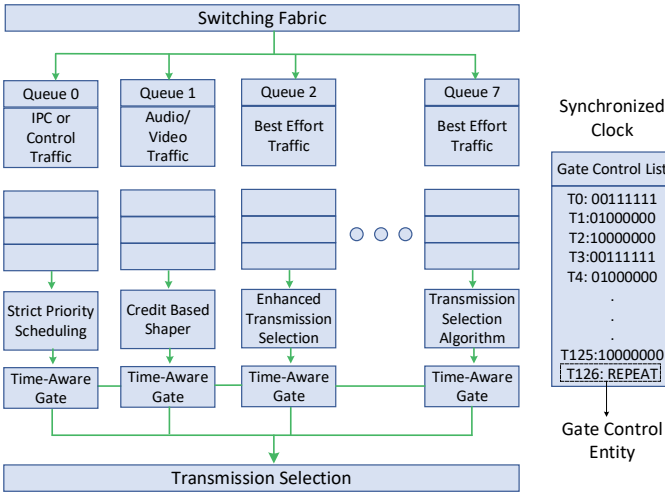

Fig. 10. IEEE 802.1Qbv: Illustration of egress HW queue with 8 SW queues, each with its unique transmission selection algorithm. The transmissions are controlled by the Gate Controlled List (GCL) with multiple Gate Control Entries (GCEs) that determine which SW queues are open. For instance, in time interval T0, the gates for queues 2 through 7 are open, and the transmission selection at the bottom arbitrates access to the medium [37, Section 8.6.8]. In time interval T1, the gate opens for AV traffic from Queue 1, and a credit based shaper (CBS) regulates the frame transmissions from Queue 1. In time interval T2, the gate opens for Queue 0 and strict priority scheduling selects the frames to transmit from Queue 0.

is intended to bound delays to under $250 \mu\text{s}$ per bridge [42]. Overall, the IEEE 802.1Qav Ethernet AVB standard guarantees worst-case latencies under 2 ms for class A and under 50 ms for class B up to seven network hops [45].

However, some key CBS disadvantages are that the average delay is increased and that the delay can be up to $250 \mu\text{s}$ per hop, which may be too high for industrial control applications [61]. Also, CBS struggles to maintain delay guarantee at high link utilizations. In order to address the CBS shortcomings, the TSN TG has introduced other standards, e.g., IEEE 802.1Qbv, 802.1Qch, and 802.1Qcr, which are reviewed in the following subsections. Also, addressing the CBS shortcomings is an active research area, see Section IV-C.

2) *IEEE 802.1Qbv Enhancements to Traffic Scheduling: Time-Aware Shaper (TAS):* As a response to the IEEE 802.1Qav shortcomings, the TSN task group proposed a new traffic shaper, namely the IEEE 802.1Qbv Time-Aware Shaper (TAS) along with the IEEE 802.1Qbu frame preemption tech-

nique to provide fine-grained QoS mechanisms. These QoS mechanisms are suitable for traffic with deterministic end-to-end ULL requirements, e.g., for critical control or Interprocess Communication (IPC) traffic, with sub-microseconds latency requirements. In particular, the Time-Aware Shaper (TAS) schedules critical traffic streams in time-triggered windows, which are also referred to as protected traffic windows or as time-aware traffic windows. Thus, TAS follows the TDMA paradigm, similar to Flexible Time-Triggered Ethernet (FTT-E) [62], [63], whereby each window has an allotted transmission time as shown in Fig. 9. In order to prevent lower priority traffic, e.g., best effort traffic, from interfering with the scheduled traffic transmissions, scheduled traffic windows are preceded by a so-called guard band.

TAS is applicable for ULL requirements but needs to have all time-triggered windows synchronized, i.e., all bridges from sender to receiver must be synchronized in time. TAS utilizes a gate driver mechanism that opens/closes according to a known and agreed upon time schedule, as shown in Fig. 10 for each port in a bridge. In particular, the Gate Control List (GCL) in Fig. 10 represents Gate Control Entries (GCEs), i.e., a 1 or 0 for open or close for each queue, respectively. The frames of a given egress queue are eligible for transmission according to the GCL, which is synchronized in time through the 802.1AS time reference. The period during which a gate is open is referred to as the time-aware traffic window. Frames are transmitted according to the GCL and transmission selection decisions, as illustrated in Fig. 10. Each individual software queue has its own transmission selection algorithm, e.g., strict priority queuing (which is the default). Overall, the IEEE 802.1Qbv transmission selection at the bottom of Fig. 10 transmits a frame from a given queue with an open gate if: (i) The queue contains a frame ready for transmission, (ii) higher priority traffic class queues with an open gate do *not* have a frame to transmit, and (iii) the frame transmission can be completed before the gate closes for the given queue. Note that these transmission selection conditions ensure that low priority traffic is allowed to *start* transmission only if the transmission will be completed by the start of the scheduled traffic window for high priority traffic. Thus, this transmission selection effectively enforces a “guard band” to prevent low priority traffic from interfering with high priority traffic, as

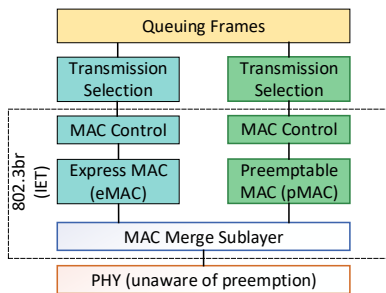

Fig. 12. Illustration of the layering for the Ethernet MAC Merge Sublayer: The MAC Merge Sublayer provides a Reconciliation Sublayer (RS) service for pMAC and eMAC frames. The RS service supports two main ways to hold transmission of a pMAC frame in the presence of an eMAC frame: By preempting (interrupting) the pMAC frame transmission, or by preventing the start of the pMAC frame transmission.

illustrated in Fig 11.

One critical TAS shortcoming is that some delay is incurred due to additional sampling delay, i.e., due the waiting time until the next time-triggered window commences. This sampling delay arises when unsynchronized data is passed from an end-point to the network. Task and message scheduling in end-nodes would need to be coupled with the TAS gate scheduling in the networks in order to achieve the lowest latencies. Moreover, synchronizing TSN bridges, frame selections, and transmission times across the network is nontrivial in moderately sized networks, and requires a fully managed network. Also, the efficient use of bandwidth with TAS needs to be thoroughly examined. Overall, TAS has high configuration complexity. Future research needs to carefully examine the scalability to large networks, the run-time reconfiguration, and the integration of independently developed sub-systems.

3) *IEEE 802.3br and 802.1Qbu Interspersing Express Traffic (IET) and Frame Preemption*: To address the ULL latency requirements and the inverted priority problem, i.e., the problem that ongoing transmission of a lower priority frame prevents the transmission of higher priority frames, the 802.1 TG along with the 802.3 TG introduced frame preemption (802.1Qbu and 802.3br) [47], [48]. Frame preemption separates a given bridge egress port into two MAC service interfaces, namely preemptible MAC (pMAC) and express MAC (eMAC), as illustrated in Fig. 12. A frame preemption status table maps frames to either pMAC or eMAC; by default all frames are mapped to eMAC. Preemptible frames that are in transit, i.e., they are holding on to the resource (transmission medium), can be preempted by express frames. After the transmission of an express frame has completed, the transmission of the preempted frame can resume.

With preemption, the guard band in Fig. 9 can be reduced to the transmission time of the shortest low priority frame fragment. Thus, in the worst case, the transmission of the low priority frame fragment can be completed before starting the transmission of the next high priority frame. The leftover fragmented frame can then be resumed to completion. Note that this preemption occurs only at the link-level, and any fragmented frame is reassembled at the MAC interfaces. Hence the switches process internally only complete frames. That is, any frame fragments transmitted over a physical link to the next

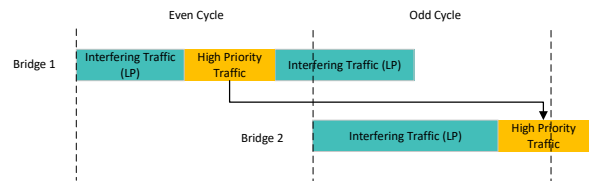

Fig. 13. Illustration of Cyclic Queuing and Forwarding (CQF) without preemption for a linear network: Each High Priority (HP) traffic frame scheduled on a cycle (even or odd) is scheduled to be received at the next bridge in the next cycle, whereby the worst-case HP frame delay can be two cycle times. In the illustrated example, the HP traffic is delayed due to low priority interfering traffic, but still meets the two cycle time delay bound.

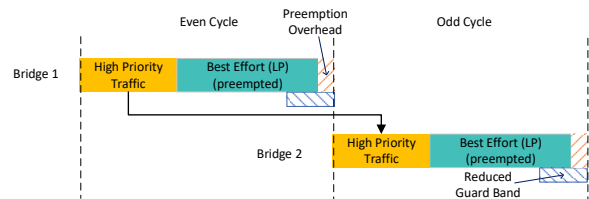

Fig. 14. Illustration of CQF with preemption for a linear network: A Guard Band (GB) before the start of the cycle prevents any Interfering Traffic (IF) from affecting the High Priority (HP) traffic.

bridge are re-assembled in the link layer interface; specifically, the MAC merge sublayer (see Fig. 12) in the link layer of the next bridge, and the next bridge then only processes complete frames. Each preemption operation causes some computational overhead due to the encapsulation processing by the bridge to suspend the current fragment and to transition the operational context to the express traffic frame and vice versa, which is illustrated in Fig. 11. Note that this overhead occurs only in layer 2 in the link interface.

4) *IEEE 802.1Qch Cyclic Queuing and Forwarding (CQF)*: While the IEEE 802.1Qav FQTSS with CBS works well for soft real-time constraints, e.g., A/V traffic, the existing FQTSS has still several shortcomings, including, *i*) pathological topologies can result in increased delay, and *ii*) worst case delays are topology dependent, and not only hop count dependent, thus buffer requirements in switches are topology dependent. The TSN TG introduced Cyclic Queuing and Forwarding (CQF) [49], also known as the Peristaltic Shaper (PS), as a method to synchronize enqueue and dequeue operations. The synchronized operations effectively allow LAN bridges to synchronize their frame transmissions in a cyclic manner, achieving zero congestion loss and bounded latency, independently of the network topology.

Suppose that all bridges have synchronized time, i.e., all bridges are 802.1AS enabled bridges, and suppose for the simplicity of the discussions that wire lengths and propagation times are negligible. Then, time sensitive streams are scheduled (enqueued and dequeued) at each time interval or cycle time with a worst case deterministic delay of two times the cycle time between the sender (talker) and the downstream intermediate receiver, as illustrated in Fig. 13. In essence, the network transit latency of a frame is completely characterized by the cycle time and the number of hops. Therefore, the frame latency is completely independent of the topology parameters and other non-TSN traffic.

CQF can be combined with frame preemption specified in IEEE 802.3Qbu, to reduce the cycle time from the transmission time of a full size frame to the transmission time of a maximum size frame fragment (plus all the TSN traffic), as illustrated in Fig. 14. Note however that for CQF to hold true, all frames must be kept to their allotted cycles, i.e., all transmitted frames must be received during the expected cycle at the receiving downstream intermediate bridge [49]. Therefore, the cycle times, the alignment of the cycle times among the bridges in the network, and the timing of the first and last transmissions within a cycle need to be carefully considered in order to ensure that the desired latency bounds are achieved. To this end, CQF in conjunction with IEEE 802.1Qci ingress policing and IEEE 802.1Qbv Time-Aware Shaper ensures that all frames are kept within a deterministic delay and guaranteed to be transmitted within their allotted cycle time.

5) *IEEE 802.1Qcr Asynchronous Traffic Shaping (ATS)*: While CQF and TAS provide ULL for critical traffic, they depend on network-wide coordinated time and, importantly, due to the enforced packet transmission at forced periodic cycles, they utilize network bandwidth inefficiently [61]. To overcome these shortcomings, the TSN TG has proposed the IEEE 802.1Qcr Asynchronous Traffic Shaper (ATS) [50], which is based on the urgency-based scheduler (UBS) [61]. The ATS aims to smoothen traffic patterns by reshaping TSN streams per hop, implementing per-flow queues, and prioritizing urgent traffic over relaxed traffic. The ATS operates asynchronously, i.e., bridges and end points need not be synchronized in time. Thus, ATS can utilize the bandwidth efficiently even when operating under high link utilization with mixed traffic loads, i.e., both periodic and sporadic traffic.

The UBS is based on the Rate-Controlled Service Disciplines (RCSDs) [64]. RCSDs are a non-work conserving class of packet service disciplines which includes Rate-Controlled Static Priority [65] and Rate-Controlled Earliest Deadline First [66]. The RCSD packet scheduling consist of two components: the rate controller implements the rate-control policies, and the scheduler implements the packet scheduling according to some scheduling policy, e.g., Static-Priority, First-Come-First-Serve, or Earliest Due-Date First. By separating the rate controller and scheduler, the RCSD effectively decouples the bandwidth for each stream from its delay bound, i.e., allocating a prescribed amount of bandwidth to an individual stream is independent of the delay bound. Hence, RCSD can support low delay and low bandwidth streams.

UBS adds a few improvements to RCSDs [64], namely: 1) UBS provides low and predictable worst-case delays even at high link utilization, 2) low implementation complexity due to the separation of per-flow queues from per-flow states where flow state information, such as Head-of-Queue frame and time stamp, is stored, 3) temporal complexity where individual flow delays are analyzed at each hop, i.e., per-hop delay calculation, and end-to-end delays are calculated based on the network topology and by the closed-form composition of the per-hop delays calculated initially, 4) independence of the global reference time synchronization.

The fundamental aim of the RCSD is to individually control frame selection and transmission at each hop between the

transmitter and receiver, i.e., per hop shaping. As pointed out by Specht et al. [61], the RCSD has multiple scalability problems, including dynamic reordering of packets within separate queues according to the packets' eligibility times, i.e., priority queue implementation with non-constant complex data structures, such as heaps. Specialized calendar queues have been proposed to achieve constant complexity [61]. However, calendar queues require RCSD capable switches to have large memory pools, are difficult to control as the network size scales up, and are ideal only for some specific applications with special properties. Therefore, Specht et al. [61] utilize the RCSD concept with the outlined improvements and have proposed a novel UBS solution as the core of the ATS standard.

6) *Summary and Lessons Learned*: Flow control mainly enforces rules to efficiently forward and appropriately queue frames according to their associated traffic classes. All existing flow controls follow similar principles, namely, certain privileges are associated with TSN flows while non-TSN flows are delayed. Nearly all existing schedulers and shapers enforce fair transmission opportunities according to each flow's traffic class. The transmission selection algorithm selects the appropriate stream within a given traffic class according to the network and traffic conditions. Flow control collaborates with flow management, see Section III-C, and flow integrity, see Section III-E, to ensure adequate resources are available for TSN streams.

Overall, we can classify real-time TSN systems into event-triggered systems and time-triggered systems. For example, IEEE 802.1Qbv is a time-triggered shaper, while IEEE 802.1Qcr is an event-triggered shaper. An interesting future research direction is to explore whether both types of shapers can be combined. That is, would it be efficient to dynamically change a flow's priority, individually or collectively, and to reshape flows based on neighbor network conditions while each flow is shaped by a centralized computed schedule incorporating time slots at each egress's port? For example, a stream initially sent with a certain high priority can be downgraded to low priority based on downstream network conditions while adhering to each bridge's time-aware scheduler and gating mechanism.

Also, it will be interesting to investigate whether IEEE 802.1Qbv can be replaced with an event-triggered shaper that guarantees an upper bound on latency, but not generally a deterministic latency. Changing TAS into an event-triggered shaper can lead to more flexible and easily computed schedules since certain events, e.g., incoming frames or network changes, can determine the schedule at runtime due to reconfiguration.

E. Flow Integrity

To accomplish the goals of deterministic ultra-low latency, jitter, and packet loss, TSN streams need to deliver their frames regardless of the dynamic network conditions, including physical breakage and link failures. Several techniques have been standardized to enable flow integrity.

1) *IEEE 802.1CB Frame Replication and Elimination for Reliability (FRER)*: IEEE 802.1CB Frame Replication and

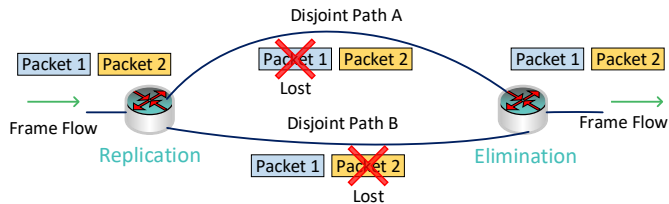

Fig. 15. Illustration of FRER operation: The first bridge replicates the frame and transmits the duplicated frames on two disjoint paths. The FRER operation can be started and ended at any bridge between the sender and receiver.

Elimination for Reliability (FRER) [51], is a stand-alone standard that ensures robust and reliable communication using proactive measures for applications that are intolerant to packet losses, such as control applications. 802.1CB FRER minimizes the impact of congestion and faults, such as cable breakages, by sending duplicate copies of critical traffic across disjoint network paths, as shown in Fig. 15. If both frames reach their destination, the duplicate copy is eliminated. If one copy fails to reach its destination, the duplicate message can still be received, effectively providing seamless proactive redundancy at the cost of additional network resources.

In order to minimize network congestion, the packet replication can be selected based on traffic class and the path information acquired through the TSN stream identification (*stream_handle*), plus a sequence generation function. The sequence generation function generates identification numbers for replicated frames to determine which frames to discard and which to pass on to as to ensure correct frame recovery and merging. The frame redundancy information is carried in a Redundancy Tag [51]. Frame sequence numbers and timing information are also needed for efforts to limit the memory needed for duplicate frame detection and elimination. For example, FRER may only be employed for critical traffic, while best effort and other loss-tolerant traffic is transmitted normally. FRER is compatible with industrial fault-tolerance architectures, e.g., High Availability and Seamless Redundancy (HSR) [67] and the Parallel Redundancy Protocol (PRP) [68]. We note that frame duplication, routing, and elimination are non-trivial tasks that will likely require centralized management. Hence, such protocols can be combined with other standards, e.g., 802.1Qcc and 802.1Qca, to ensure seamless redundancy and fast recovery in time-sensitive networks.

2) *IEEE 802.1Qca Path Control and Reservation (PCR)*: IEEE 802.1Qca Path Control and Reservation (PCR) is based on and specifies TLV extensions to the IETF Link State Protocol (LSP), the Intermediate Station to Intermediate Station (IS-IS) protocol [69]. IEEE 802.1Qca allows the IS-IS protocol to control bridged networks beyond the capabilities of shortest path routing (ISIS-SPB) [37], [70, Section 28], configuring multiple paths through the network [52], [71]. IEEE 802.1Qca PCR aims to integrate control protocols required to provide explicit forwarding path control, i.e., predefined protected path set-up in advance for each stream, bandwidth reservation, data flow redundancy (both protection and restoration), and

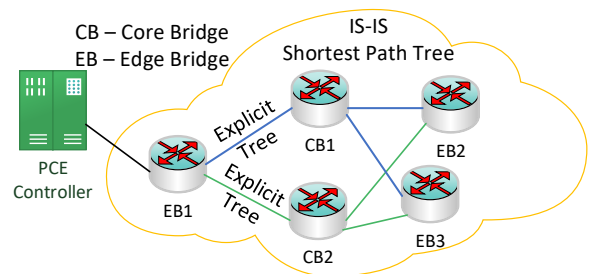

Fig. 16. Illustration of Explicit Paths (EPs): A control plane PCE SDN controller installs computed Explicit Tree (ET) paths via the IS-IS data plane. Two computed ET paths are shown represented by the green and blue lines.

distribution of control parameters for flow synchronization and flow control messages [52].

In general, 802.1Qca specifies bridging on explicit paths (EPs) for unicast and multicast frame transmission, and protocols to determine multiple active topologies, e.g., Shortest Path, Equal Cost Tree (ECT), Internal Spanning Tree (IST), Multiple Spanning Tree Instance (MSTI), and Explicit Tree (ET), in a bridged network. Explicit forwarding paths, as opposed to hop-by-hop forwarding, mitigate disruptions caused by the reconvergence of bridging protocols. PCR has similar goals and evolved from spanning tree protocols, e.g., the Rapid Spanning Tree Protocol (RSTP) [37, Section 13.4], the Multiple Spanning Tree Protocol (MSTP) [37, Section 13.5], and the Shortest Path Bridging (SPB) [37, Section 27].

The IEEE 802.1Qca standard is based on Shortest Path Bridging (SPB) [37, Section 27] and incorporates a Software Defined Networking (SDN) hybrid approach [52]. In the hybrid approach, the IS-IS protocol in the data plane handles basic functions, e.g., topology discovery and default path computation, while the SDN controller [72] in the control plane manages the Explicit Paths (EPs), as shown in Fig. 16. In particular, the controller utilizes dedicated path computation server nodes called Path Computation Elements (PCEs) [73], defined by the IETF PCE WG [73], to manage the EPs. A PCE interacts with the IS-IS protocol to handle and install requests for the network and can interact with the SRP protocol, see Section III-C, to reserve resources along the EPs. Additionally, the PCEs can manage redundancy on the EPs, thus providing protection on top of the EPs by utilizing alternate paths, e.g., Loop Free Alternates (LFAs) [52], that reroute in a few milliseconds.

3) *IEEE 802.1Qci Per-Stream Filtering and Policing (PSFP)*: The IEEE 802.1Qci per-stream filtering and policing (PSFP) standard [53], also known as ingress policing/gating standard, allows for filtering and policing of individual traffic streams based on rule matching. IEEE 802.1Qci prevents traffic overload conditions, that are caused, for instance, by erroneous delivery due to equipment malfunction and Denial of Service (DoS) attacks, from affecting intermediate bridge ports and the receiving end station, i.e., improves network robustness. IEEE 802.1Qci may be used to protect against software bugs on end points or bridges, but also against hostile devices and attacks. IEEE 802.1Qci specifies filtering on a per flow (stream) basis by identifying individual streams with a *StreamID*, which utilizes the 802.1CB stream handler

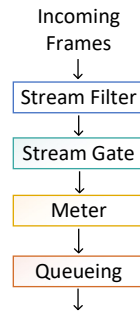

Fig. 17. Illustration of PSFP flow: The flow is first filtered according to per-flow policies. Then, a gating mechanism regulates the flow. Finally, flow metering ensures bandwidth limitations before a frame is queued for forwarding.

method [51]. The identified individual streams can then be aggregated, processed, and finally queued to an input gate. As illustrated in Fig. 17, each gate performs three functions.

The PSFP stream filter performs per-flow filtering by matching frames with permitted stream IDs and priority levels, and then applies policy actions. The PSFP stream gate coordinates all streams such that all frames proceed in an orderly and deterministic fashion, i.e., similar to the 802.1Qch signaling process, see Section III-D4. The PSFP flow metering enforces predefined bandwidth profiles for streams. The metering may, for instance, enforce prescribed maximum information rates and burst sizes.

4) *Summary and Lessons Learned:* Flow integrity provides path redundancy, multi-path selection, as well as queue filtering and policing. Flow integrity supports the ULL performance by enforcing such functions and preventing unauthorized or mismanaged and rogue streams on bridged LAN networks.

In general, as network devices improve in terms of hardware performance, they can be equipped with more state information within the core network. The increased state information allows for fine granular QoS management at the expense of control messages for efficient control dissemination in the network. Future research needs to carefully examine the trade-offs between disseminating more extensive control messages and the resulting QoS management improvements.

F. Discussion on TSN Standardization Efforts

The IEEE TSN TG has standardized deterministic networking for Layer 2 Ethernet based bridging LANs. These standards have been revised and continue to be updated to reflect the convergence of the industrial and consumer markets. Overall, the TSN standards guarantee the required QoS requirements for data transmission and provide sufficient measures to enable end-to-end functional communication safety in the network. Essentially, the TSN standardization provides the recommended practices for enabling low latency, jitter, and data loss, as well as redundancy and reservation. In addition, the TSN standardization provides mechanisms for bandwidth limitation, dynamic reconfiguration, centralized management, and strict timing features.

Timing measurement and sub-microsecond time synchronization as basis for TSN standard mechanisms can be

achieved with IEEE 802.1AS and the updated revised version 802.1AS-REV. Essentially, all gPTP network entities contribute to distributing and correcting delay measurement timing information based on the source GM. 802.1AS-REV provides, among others, GM redundancy for faster convergence.

Several flow management standards, including IEEE 802.1CB (FRER), 802.1Qca (PCR), 802.1Qci (PSFP), 802.1Qcc (Enhanced SRP and centralized Management), 802.1CS (LRP) and RAP have been published or are in progress to enable redundancy, path reservation, bandwidth limitation, dynamic reconfiguration, as well as overall flow integrity and management. Although standard Ethernet provides redundancy features, e.g., through spanning tree protocols, the convergence time in the event of a failure is too slow for real-time IACS applications. Therefore, FRER is used to proactively enable seamless data redundancy at the cost of additional bandwidth consumption. Moreover, PCR in combination with FRER and 802.1Qcc enables fast recovery, efficient path redundancy, and management functionalities for flows dynamically at runtime. Furthermore, PSFP manages, controls, and prevents rogue flows from deteriorating the network performance. Since SRP and the related signaling protocols are fully distributed mechanisms targeted towards AVB applications, the SRP and MRP protocols are not scalable to large networks with real-time IACS applications due to a limited state information database for the registered flows, see Section III-C3. Therefore, LRP in conjunction with RAP as the signaling protocol features a decentralized approach to support resource reservations for scalable TSN enabled networks.

To achieve low latency, several flow control standards have been released, including IEEE 802.1Qbv (TAS), 802.1Qch (CQF), and IEEE 802.1Qcr (ATS). For TAS, IEEE 802.1Qbu frame preemption can ensure that the transmission channel is free for next express traffic transmission. CQF can coordinate ingress and egress operations to reduce the TAS configuration complexity, albeit at the expense of higher delays. Finally, ATS has been proposed to provide deterministic operations independently of the reference time synchronization and low delays for high link utilization. The efficient dynamic configuration of these flow control standard mechanisms, including IEEE 802.1Qbv, is an open challenge that requires extensive future standardization and research efforts.

The TSN standardization has so far excluded the specific consideration of security and privacy. The IEEE 802.1 Security TG has addressed security and privacy in general IEEE 802.1 networks, i.e., functionalities to support secure communication between network entities, i.e., end stations and bridges. The TG has detailed a number of standards and amendments, including 802.1X Port-based Network Access Control (PNAC) [74], [75], 802.1AE MAC Security (MACsec) [76]–[79], and 802.1AR Security Device Identity (DevID) [80], that focus on providing authentication, authorization, data integrity, and confidentiality. Specifically, PNAC utilizes industry standard authentication and authorization protocols enabling robust network access control and the establishment of a secure infrastructure. Furthermore, PNAC specifies the MACsec Key Agreement (MKA) [75] protocol. MACsec specifies the use of cryptographic cipher suites, e.g., Galois/Counter Mode of

Advanced Encryption Standard cipher with 128-bit key (GCM-AES-128), that allow for connectionless user data confidentiality, frame data integrity, and data origin authentication, essentially providing a set of protocols that ensures protection for data traversing Ethernet LANs. For instance, DevID is a unique per-device identifier that cryptographically binds a device to the DevID. Thus, 802.1 LAN devices can be authenticated and appropriate policies for transmission and reception of data and control protocols to and from devices can be applied. The IEEE 802.1 Security TG is working on a couple of amendments to address privacy concerns and to include a YANG model allowing configuration and status reporting for PNAC in 802.1 LANs. The integration of the security protocols and standards with TSN enabled networks needs to be addressed in future research and standardization. For instance, the impact of the security stack overhead on TSN flows and the impact of the security overhead on OT related applications running over Ethernet LANs need to be investigated. Thus, there are ample research opportunities for testing and benchmarking to ensure the efficient integration of legacy security protocols with TSN.

The important area of networks for industrial applications often employs cut-through switching techniques. An interesting future research direction is to investigate how networking with cut-through switching compares with networking based on the TSN standards (tool sets).

More broadly, even though many standards and recommended practices addressing deterministic networking have been published, significant testing and benchmarking is needed to provide assurances to the industry and consumer markets.

IV. TSN RESEARCH STUDIES

This section surveys the existing research studies towards achieving ULL in the context of the TSN standards. The TSN standards provide tool sets to enable TSN characteristics, such as flow synchronization and flow control (see Sec. III), in conventional networks. Based on the application requirements, various TSN standard tools can be independently and selectively adopted on network segments to enable TSN characteristics. Similar to the organization of the review of TSN standards in Fig. 1, we organize the survey of TSN related research studies in Fig. 18 according to the same classification as the TSN standards in Fig. 1. To date there have been no specific research studies on the TSN flow concept; therefore, we omit the flow concept category in Fig. 18.

A. Flow Synchronization

1) *Clock Precision*: Most existing time synchronization implementations are limited to clock precisions on the order of sub-microseconds [100]. The global sharing of the timing information across the network elements allows the clocks in the network elements to be precisely synchronized relative to each other (see Section III-B). The challenges associated with network wide clock synchronization are not limited to one particular network attribute. Rather, a wide set of network attributes, including hardware capabilities, such as clock stability, and isolation from environmental impacts e.g.,

temperature, and software implementations, e.g., for designing an effective closed-loop system to track and correct the timing drifts, influence the synchronization quality in the network as a whole. As a result, most current deployments rely on sub-microseconds clock precision techniques. However, future trends in network applications require a tighter clock synchronization on to the order of sub-nanoseconds in Ethernet networks. For instance, the control system of the CERN Large Hadron Collider (LHC) communication network has to operate with sub-nanosecond precision to share timing and perform time-trigger actions [101].

Gutierrez et al. [81] have analytically evaluated the synchronization process and the quality of the timing error estimation in large scale networks based on the IEEE 802.1AS TSN synchronization standard. In particular, Gutierrez et al. focused on the clock synchronization quality with a small margin of error between each node for a large network consisting of a few thousand nodes with maximum distances between the grandmaster clock and synchronized node clocks spanning up to 100 hops. The study of the protocol behavior included various network aspects, including clock granularity, network topology, PHY jitter, and clock drift. The results from probabilistic analytical modeling and simulation evaluations indicate that implementation specific aspects, such as PHY jitter and clock granularity, have a significant impact on the clock precision with deviations reaching $0.625 \mu\text{s}$ in the TSN synchronization process. Therefore, it is critical to ensure that the physical properties of the clock within each node are accurate so as to ensure the overall quality of the synchronization process in TSN networks that adopt IEEE 802.1AS.

2) *Frequency Synchronization*: Li et al. [82] have introduced a novel networking device architecture that provides ULL switching and routing based on synchronization. Their design integrates a state-of-the-art FPGA with a standard x86-64 processor (which supports both 32 and 64 bit operation) to support TSN functions. The system provides frequency synchronization over standard Ethernet to the entire network. Frequency synchronization enables distribution of timing information with low-jitter across the network. In the frequency synchronization design illustrated in Fig. 19, datapaths are enabled with one or more synchronous modules supported by clock synchronization. These datapaths are allocated resources in terms of bit rate and packet rate based on the worst-case traffic load. This design exploiting hardware synchronization capabilities achieves cut-through latencies of 2 to $2.5 \mu\text{s}$ for twelve Gigabit Ethernet ports at full line rate packet processing [82]. The constituents of the observed latency were identified as pipeline delay, arbitration delay, aggregation delay, backpressure cycles, cross-clock domain synchronization cycles, datapath width adaptation cycles, and head-of-line blocking cycles. Emphasizing the importance of the hardware implementation of the frequency synchronization process, Li et al. [82] suggest that their novel hardware implementation and timing distribution process based on frequency synchronization across networks can be easily extended to other custom designs.

3) *Timing Accuracy*: Although TSN protocols offer very accurate timing information for the inter clock alignment, the

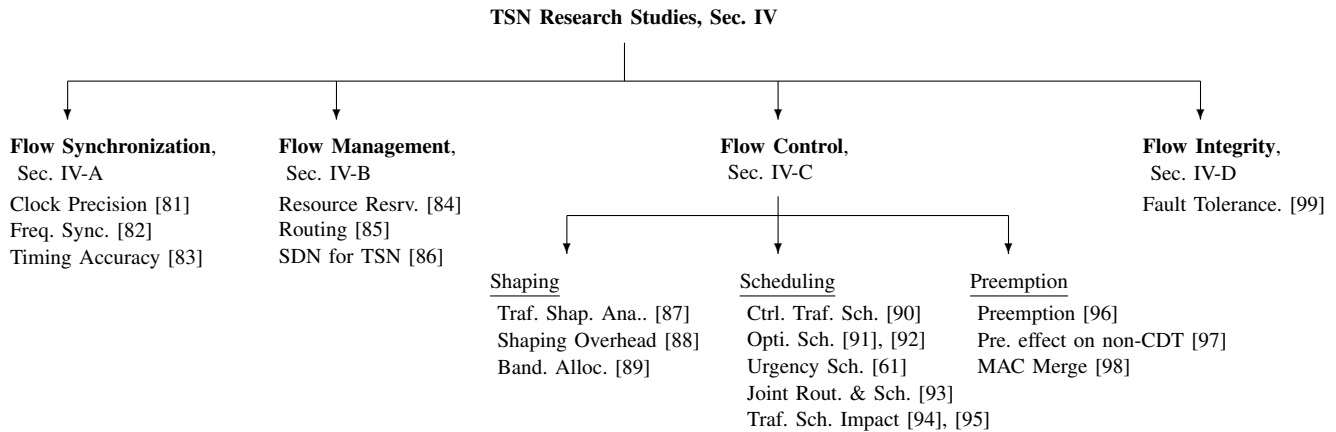

Fig. 18. Classification of TSN research studies.

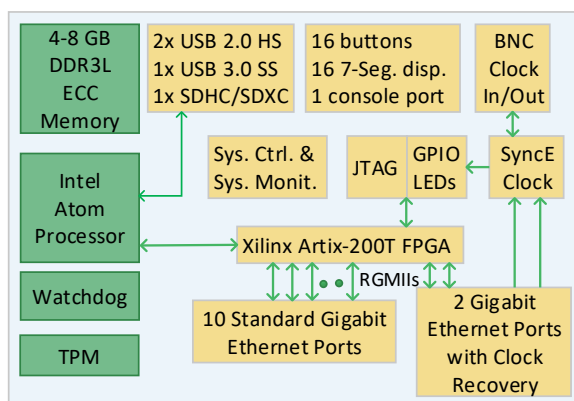

Fig. 19. Illustration of frequency synchronization design supporting TSN with clock recovery and network wide synchronization [82].

validity and accuracy of the received timing information can still be uncertain. That is, typically the timing information received from the grand master is blindly followed by the clock alignment process, which can potentially result in out-of-sync clocks if the received timing information is not accurate. The detection of erroneous timing information by the receiving node can potentially help time critical network applications to re-trigger the verification, calibration, and re-synchronization process. Moreover, nodes can use this information to alert network applications to request a new path or to terminate critical operations that require timing precision. Therefore, timing accuracy is an essential aspect in TSN networks.

The time-error is the relative clock difference between the slave and the grand master. The time-error can still exist even if the slave node applies the timing corrections based on timing error estimation. The timing accuracy represents the overall quality of the timing distribution throughout the network. The timing accuracy at a node can be estimated in two ways: *i*) by receiving the timing information from another source and periodically comparing to check the accuracy, and *ii*) keeping track of the node's self error and (ingress and egress) port latencies to predict the inaccuracy in the received timing. Noseworthy et al. [83] have specifically addressed the timing inaccuracy of a Precision-Time Protocol (PTP) node with the help of an auxiliary node. The proposed network-based system

monitors and measures the timing errors and port latencies to track the self errors independently of the PTP protocol and network application. Such systems can share the information with other nodes so that the other nodes can estimate the timing errors. In addition to the timing error of a PTP node, the ingress and egress delays in the PTP nodes for a specific TSN flow have been estimated and used in the process of clock reference maintenance.

4) *Summary and Lessons Learnt*: An important aspect of timing and synchronization in TSN networks is to estimate the relative timing difference between two nodes. Timing differences may arise because of clock errors, synchronization errors, as well as tracking and estimation errors [10]. Clock errors are caused by the timing drifts resulting from hardware imperfections. Synchronization errors are caused by false timing information and wrong interpretation of timing information. Tracking and estimation errors can arise due to implementation errors. For instance, if a device is in a sleep mode for power savings, the tracking of clock errors can be impacted. In order to achieve high-order precision in the clock implementation for TSN applications, all aspects of the clock errors must be considered to mitigate the effects arising from wrong local timing.

The clock synchronization in the network requires significant bandwidth, i.e., imposes a significant overhead in the network. The synchronization data needs to be propagated throughout the network in a deterministic fashion. Hence, the synchronization traffic interferes with the scheduled and regular traffic. Therefore, the design of TSN networks requires careful consideration of the overhead resulting from the synchronization process and efforts to reduce the overhead. On the other hand, the effectiveness of the protocol that facilitates the synchronization process is limited by the node capability to preserve a synchronized local clock. If the local clock skew is high compared to the frequency of the synchronization process, then the local clock will always have the wrong timing. Therefore, the future design of synchronization protocols and the frequency of synchronization should be based on the node characteristics.

B. Flow Management

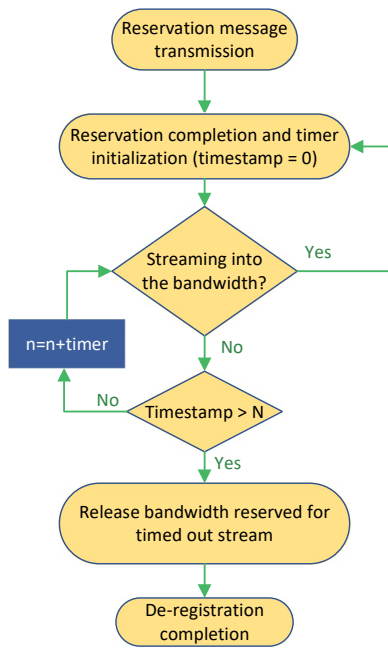

Fig. 20. The automatic flow de-registration process monitors the network for transmission activity and removes the resource reservations when a flow is idle for more than a threshold duration [84].

1) *Resource Reservation*: A resource reservation process is typically applied across the network elements so as to ensure that there are sufficient resources for processing TSN flow frames with priority. The TSN IEEE 802.1 Qat protocol defines the resource reservation mechanism in TSN networks, see Section III-C2. Park et al. [84] revealed that the TSN IEEE 802.1 Qat standard lacks effective procedures for terminating reserved resources. The existing standardized resource release mechanism involves signaling among TSN nodes to establish a distributed management process, such that the connection reservations are torn-down and the resources released when the TSN flow is no longer needed. Similarly, when there is a renewed need for the TSN flow, the connection with its resource reservation is re-initiated based on the flow's traffic requirements. For networks with a few nodes and short end-to-end delays, the management process has relatively low signaling complexity and does not significantly impact the TSN flows. However, Park et al. [84] found that the numbers of nodes that are typical for in-vehicle networks result in a pronounced increase of the overall control message exchanges for the tear-down and re-initiation of connections.

Therefore, Park et al. [84] have proposed an automatic de-registration to tear-down reservations. All participating nodes run the algorithm to de-register the reserved resources in a synchronized manner across the entire network based on the network wide synchronization capability in TSN networks. Figure. 20 presents the flow chart of the automatic de-registration process: A timer is initialized to track the idle times for a specific TSN flow. Once the timer meets a predefined threshold, the resource reservations of the flow are automatically torn-down by all the participating nodes. The de-registration process is simultaneously performed throughout the network based on the synchronized timers. The downside

of such an automatic de-registration process is the overhead for the re-activation process of the resource reservation for TSN flows which were deactivated due to a short period of inactivity. Thus, for highly bursty traffic, the automatic de-registration process may negatively impact the overall network performance since the idle times between traffic bursts may trigger the automatic de-registration.

2) *Bandwidth Allocation*: Bandwidth allocation reserves the physical transmission resources required to meet the delay requirements of an end-to-end flow. A specific bandwidth allocation challenge in TSN arises from the multiple traffic classes, such as the different priority levels for scheduled traffic and best-effort non-scheduled traffic.

Ko et al. [89] have developed a simulation model to study the impact of the Maximum Transmit Unit (MTU) size of TSN traffic packets on the performance for scheduled traffic within a specific bandwidth allocation framework. Specifically, Ko et al. have presented an optimal bandwidth allocation for the scheduled traffic based on TSN definitions. The optimal bandwidth allocation proposed by Ko et al. reserves 25% of the bandwidth to best-effort traffic while the remaining 75% of bandwidth is allocated to different QoS traffic classes. In particular, two classes of QoS traffic were considered, namely scheduled traffic and audio/video traffic. Bandwidth is allocated such that the total bandwidth allocated to scheduled and audio/video is always 75%. The allocation ratio between scheduled and best-effort traffic is maintained constant, while the proposed algorithms changes the bandwidth ratio between the scheduled traffic and the audio/video traffic. The bandwidth allocation for the scheduled traffic was varied by varying its MTU size. The typical in-vehicle network simulations found that an MTU size of 109 bytes optimally allocated bandwidth to the scheduled traffic, which achieved an average end-to-end latency of 97.6 μ s.

3) *Routing*: In contrast to routing mechanisms in conventional networks, Arif et al. [85] have proposed a computationally efficient optimization method to evaluate the routing paths for a TSN end-to-end connection. The proposed solution considers an optimality criterion that minimizes the routing path delays which effectively reduces the end-to-end latency of the TSN flows across the network. The proposed approach also considers multipath jitter, as well as the probability of loop occurrence while evaluating the end-to-end routing path of the TSN flow. The main purpose of the routing is to load balance the TSN flows in the network nodes and thus to reduce the routing path delays.

4) *Software Defined Networking for TSN*: The centralized computation and management of routing of an end-to-end TSN flow follows similar principles as the central control in the SDN paradigm. A formal adoption of the SDN paradigm in TSN networks has been presented by Nayak et al. [86]. Nayak et al. employed SDN principles to evaluate the routing of TSN flows and to apply the evaluated routes to the network nodes. As shown in Fig. 21, the proposed SDN controller implements four main management functions, namely monitor, analyze, plan, and execute to establish and control the TSN flows. Nayak et al have conducted delay and flexibility simulation evaluations of several routing mechanisms with the SDN

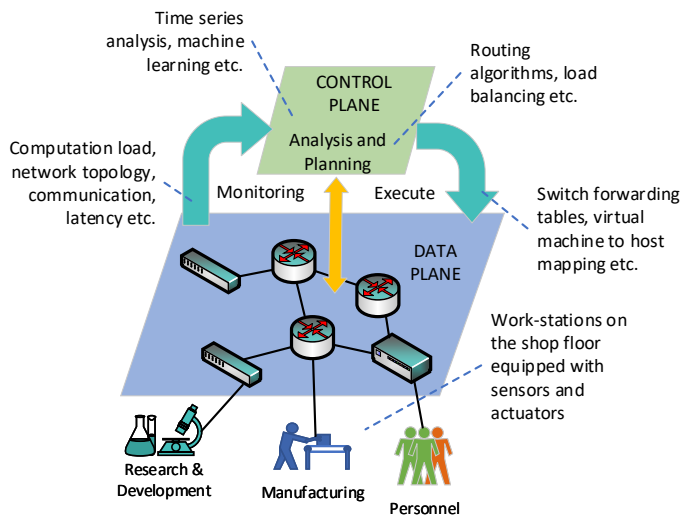

Fig. 21. Software Defined Networking (SDN) based Time Sensitive Networking (TSN) in industrial network setting: Monitoring sensors from various factory locations deliver information to centralized controller. The centralized controller applies the time sensitive networking rules across the industrial networks to support critical connectivity paths [86].

approach and without the SDN approach to quantify the benefits offered by SDN. Based on simulations, Nayak et al. have proposed the adoption of SDN to existing processes for the network management of time-sensitive applications.

While SDN inherently provides management flexibility, the actual deployment characteristics of SDN for TSN still need to be carefully characterized. Towards this goal, Thiele et al. [102] have presented the challenges in adapting SDN for TSN networks. Specifically, Thiele et al. have performed a timing analysis of an end-to-end TSN flow in the SDN framework to verify the limitations of SDN, such as overhead, scalability, and control plane delay in meeting the TSN requirements for in-vehicle networks. Thiele et al. used a compositional performance analysis framework to model the SDN network performance for TSN. The SDN deployment requires a centralized controller for the global management of the TSN network from flow establishment to tear-down. The placement of the controller among the TSN nodes can be challenging since the control signalling communication between nodes and controller can span across the entire network. Each TSN flow establishment process requires the exchange of control messages between a TSN node and the controller. As the numbers of TSN nodes and flows increase, the overhead due to control message exchanges could increase, affecting the overall TSN performance. Moreover, the flow setup process requires the TSN node to request the flow rules from the SDN controller which can increase the flow setup time as compared to a static non-SDN scenario. Therefore, to determine the feasibility of SDN for in-vehicle TSN networks an analytical formulation was verified through simulations. The simulation results demonstrate that the worst-case SDN network configuration delay is 50 ms, which is typically tolerable for admission control and fault recovery in conventional Ethernet networks.

5) *Summary and Lessons Learnt*: In addition to dynamic flow establishment based on current network characteristics, flow management ensures that TSN networks should preserve the time-sensitive characteristics, such as low end-to-end delay, when the network characteristics, such as topology and number of nodes, change. The adaptability of the network to changes in network characteristics is an important network design aspect that needs to be examined in detail in future research. This future research needs to address the control plane as well as the data plane.

Currently, IEEE 802.1Qcc has centralized management, but does not preclude distributed management. The TSN TG has started the process of chartering a project to standardize RAP, see Section III-C4, which uses distributed management. Generally, centralized management can reduce the traffic overhead and reduce the management complexity. The detailed investigation of the trade-offs between centralized and distributed management is an important direction for future research.

The static allocation of link resources to a TSN flow can result in low network efficiency. Dynamic link resource allocation provides more efficiency and flexibility. More specifically, a flow management technique can be implemented to statistically multiplex several flows sharing common network resources, while the worst-case flow performance is still bounded by a maximum prescribed value. A pitfall that needs to be carefully addressed is the network complexity in developing and deploying flow management techniques in actual networks. SDN may be a promising technology for the management of dynamic resource allocation in TSN networks. SDN also provides an inherent platform to design advanced TSN flows management mechanisms, such as admission control and security mechanisms.

C. Flow Control

The overall temporal characteristics of a TSN flow are dictated by the flow control mechanisms that are applied in the intermediate nodes. The flow control mechanism implemented at each TSN node directly impacts the process of frame traversal through each node that a particular flow is defined to pass through. A variety of flow control mechanisms are employed in the intermediate nodes before an enqueued frame is scheduled for transmission over the physical link. The most critical flow control mechanisms in TSN nodes are traffic shaping as well as scheduling and preemption.

Traffic shaping limits the traffic rate to a maximum allowed rate, whereby all traffic exceeding the maximum allowed rate is buffered and scheduled for transmissions at an available opportunity. (In contrast, traffic policing simply drops the exceeding traffic.) The downside of traffic shaping is queuing delay, while the downside of policing is that excess frame dropping can affect the TCP transmission windows at the sender, reducing the overall network throughput.

1) *Traffic Shaping*: Control-Data Traffic (CDT) is the TSN traffic class for transmissions of control traffic with the shortest possible delay. In addition to the CDT class, TSN distinguishes traffic class A and class B. Collectively, these traffic classes are shaped by the traffic shapers in the TSN nodes to meet the

delay requirements. The traffic shapers ensure that *i*) the CDT is allocated resources with strict priority, *ii*) the TSN traffic is isolated from the regular traffic, and *iii*) the wait times for enqueued frames are bounded. Towards this end, various traffic shaping methods have been standardized, see Section III-D, in order to satisfy the requirements of the flows based on their traffic classes.

a) Shaping Analysis: Thangamuthu et al. [87] have conducted a detailed comparison of the standard TSN traffic shaping methods. In particular, Thangamuthu et al. have compared the burst limiting shaper (BLS, a variation of CBS, which was considered in research but not incorporated into the TSN standard), the time aware shaper (TAS), and the peristaltic shaper (PS), see Section III-D. The simulations show that for typical 100 Mbps Ethernet network deployments the in-vehicle delay requirements are met for most applications, except for applications with strict delay requirements. Therefore, additional ULL mechanisms are recommended, in addition to the traffic shaping, to satisfy strict application requirements. Complementarily, Thiele et al. [103], [104] have conducted a formal timing analysis and worst-case latency analysis of the different shapers for an automotive Ethernet topology, while an avionics context has been considered in [105]. Moreover, the wireless fronthaul context, see Section VII-A1, has been considered in [106].

2) Traffic Shaping Overhead: Traffic shaping, in particular the TAS can significantly impact the configuration overhead throughout the network, especially for temporary (short lived) TSN flows. Typically, the TSN flows that originate from plug-and-play devices attached to the TSN network are temporary in nature. The transmission schedule for TAS gate control must be evaluated and maintained at each traversed TSN node corresponding to each temporary flow. The schedule information at each node is generated and managed as a network configuration. These network configurations must be applied across the network to establish an end-to-end TSN flow. The temporary TSN flows resulting from plug-and-play connections create a deluge of management traffic overhead due to the distributed coordination of the synchronized schedule mechanism.

To address this overhead issue, Farzaneh et al. [88] have presented an ontology based automatic configuration mechanism. Application management service and TSN management service entities coordinate the connection establishment and tear-down procedures, managing the control plane actions for the TSN network. A TSN knowledge database is implemented to track and manage new, existing, and previous connections. For each connection, QoS requirements, assignments, and source details, such as port, related topics and devices are identified and analyzed to build an ontology of TSN flows corresponding to an application and device. Thus, whenever the plug-and-play event for a specific device occurs in the network, the TSN configurations are automatically applied, lowering the overhead compared to the conventional distributed connection management. Although the automatic configuration mechanism is similar to the principles of SDN, Farzaneh et al. have discussed the process based automatic configuration mechanism independently of SDN. Nevertheless, the ontol-

ogy based automatic configuration mechanism can be easily adapted to SDN by implementing the proposed application management service and TSN management functions as an SDN application.

3) Scheduling:

a) TTEthernet vs. TSN: Craciunas et al. [107] have presented an overview of scheduling mechanisms for Time-Triggered Ethernet (TTEthernet) [108]–[110] and TSN. In the TTEthernet switch, the incoming frames for an outgoing egress port are temporarily stored in a buffer, and wait for the scheduler to assign a transmission-slot based on the precomputed schedule. In contrast, the incoming frames in TSN are directly inserted into priority queues, and these priority queues are served based on prescribed schedules. The fundamental difference between TTEthernet and TSN is the scheduling procedures, where the TTEthernet buffer is served based on global static scheduling information, i.e., a *tt-network-schedule* assigned to meet the end-to-end delay requirements. In contrast, TSN employs a dynamic schedule local to each node for control frame transmissions from priority queues. TSN switches may be synchronized to network timing and can preempt an ongoing lower priority transmission, which is not possible in a TTEthernet switch. Thus, the deployment of TSN switches as opposed to TTEthernet switches can improve support for delay critical applications. However, the implementation cost and complexity (due to synchronization) of TSN is typically higher than for TTEthernet.

b) Control Traffic Scheduling: Bello et al. [90] have presented an overview of TSN standards and examined the scheduling of control traffic flows in intra-vehicular Ethernet networks. More specifically, Bello et al. focused on the IEEE 802.1Qbv standard for scheduled traffic. Bello et al. have implemented the scheduled traffic mechanism for automotive connectivity applications by utilizing the time-sensitive properties of TSN. In particular, flow prioritization has been used to prioritize the control traffic flows over regular data flows. The traffic flows are separated into multiple priority queues and scheduling procedures are applied across the queues. Bello et al. [90] developed a simulation model for an automotive network to study the behaviors of TSN supported network modules. The simulation evaluations indicated significant latency reductions by up to 50% for the control traffic flows, i.e., the scheduled traffic flows, compared to non-scheduled traffic. A limitation of the Bello et al. [90] study is that it considered only the automotive network domain and did not consider the wider applicability and potential of TSN.

c) Optimization Based Scheduling: An important shortcoming of the IEEE 802.1Qbv standard, which defines the transmission of scheduled traffic in TSN, is that there are no specific definitions of algorithms to determine the transmission schedule of frames on a link. In addition, the IEEE 802.1Qbv standard enforces the use of time spacing, i.e., guard bands, between the scheduled traffic types. The guard bands isolate scheduled traffic belonging to a specific class from other traffic classes, including the best-effort traffic class. A critical pitfall in the IEEE 802.1Qbv standard is that as the number traffic classes increases, there can potentially be a large number of guard band occurrences during the traffic transmissions

over the link. Traffic schedules with frequent guard bands waste bandwidth and can contribute to latency increases. Hence, an important future work direction is to develop traffic transmission schedules with reduced numbers of guard band occurrences in order to prevent wasted bandwidth and to keep latencies low.

Dürr et al. [91] have modeled TSN scheduling as a no-wait job-shop scheduling problem [111]. Dürr et al. then have adapted the Tabu search algorithm [112] to efficiently compute optimal TSN transmission schedules while reducing the occurrences of guard bands. The simulations evaluations indicate that the proposed algorithm can compute the near-optimal schedules for more than 1500 flows on contemporary computing systems while reducing the guard band occurrences by 24% and reducing the overall end-to-end latency for TSN flows. With the minimal duration of guard bands, see Section IV-C4, the receivers have to be actively synchronized for the correct reception of TSN frames. The existence of guard bands in the traffic flows provides an inherent secondary synchronization for the receivers. However, it should be noted that the implementation of such optimization algorithms can increase the network node complexity as well as protocol operations, increasing the overall operational cost of the device.

Craciunas et al. [92] have examined the scheduling of real-time traffic, whereby the transmission schedules are computed through optimization methods. The constraints for the optimization problem formulation are based on the generalized TSN network configuration in terms of the characteristics of the Ethernet frames, physical links, frame transmissions, end-to-end requirements, and flow isolation. While considering a comprehensive set of parameters, the optimization problem is modeled to compute transmission schedules in online fashion (i.e., is frame arrival event driven) to achieve low latency and bounded jitter. While a complex optimization problem can provide a near optimal solution, it is also important to consider the required computation times. Addressing the complexity aspect, Craciunas et al. have proposed several extensions to the optimization process and outlined the implications for the computation time. Craciunas et al. [92] have conducted simulation evaluations for various network loads and configurations. The simulation results indicated that an optimization process can be scalable while achieving the desired level of scheduling benefits, i.e., bounded latency and jitter for an end-to-end connection carrying real-time traffic.

d) Joint Routing and Scheduling: TSN frame transmissions out of the queues can be controlled through gating (see Section III-D2), whereby a predefined event triggers the gate to transmit a frame from a queue according to a prescribed scheduling policy. With event triggering, the frame transmission follow the predefined time triggered pattern, resulting in so-called time triggered traffic [63], [109], [113]. Pop et al. [93] have designed a joint routing and scheduling optimization that evaluates the time trigger events to minimize the worst-case end-to-end frame delay. The time trigger schedule is based on an optimization problem formulated with integer linear programming. The proposed optimization problem comprehensively considers the network topology as well as time trigger flows and AVB flows. The time trigger flows follow the

shortest route, while AVB flows follow a greedy randomized adaptive search approach. Simulation evaluations indicate that the compute time to evaluate the time triggered scheduling and AVB routing optimization is acceptable as compared to the timing of the frame flows. A limitation of the approach by Pop et al. is that the optimizations are not scalable and flexible when there are changes in the properties of network infrastructures (e.g., topology changes). When there are such network infrastructure changes, then the entire optimization process must be reconfigured.

e) Impact of Traffic Scheduling: Although TSN networks provide a pathway to achieve ULL through enhancements to the existing Ethernet standards, the benefits are limited to TSN flows as opposed to best-effort traffic. That is, in case of mixed transmissions, where the TSN defined transmissions are multiplexed with non-scheduled best effort traffic transmissions, there are no guarantees for the effective behavior of the non-scheduled best-effort traffic. If there are requirements for the non-scheduled traffic, such as a hard deadline for frame delivery in an end-to-end connection, the application can be severely affected due to the interference from the scheduled TSN traffic. The behavior characterization of non-scheduled traffic can be challenging and unpredictable due to the interference from scheduled TSN traffic. Therefore, Smirnov et al. [94] have provided a timing analysis to study the uncertainty of critical non-scheduled traffic in presence of scheduled TSN traffic interference. The challenge in the characterization of scheduled interference is to consider all possible traffic scenarios, such as all possible scheduling types, resulting in long computation times. Smirnov et al. propose an approach to integrate the analysis of worst-case scheduled interference with traditional end-to-end timing analysis approaches to reduce the computation times. Such an integrated approach can estimate an upper bound on the scheduled interference for various scheduling types, and the evaluations show significant computation time reductions.

A complementary study by Park et al. [95] has investigated the performance of scheduled traffic as opposed to the non-scheduled traffic. Park et al. performed extensive simulations focusing on TSN to verify whether the end-to-end flow requirements are impacted by increasing numbers of TSN nodes in the presence of non-scheduled traffic. The simulations employed the general network wide synchronous event-triggered method for frame transmissions in TSN networks. The simulation for an in-vehicle network based on the event triggered scheduling for various traffic types show that the delay requirements of control traffic can be successfully met for up to three hops. However, the scheduled traffic needs to be transferred within at most five hops to meet the typical 100 μ s delay requirement for critical control data in in-vehicle networks.

At a given TSN node, the events to trigger an action that is then utilized for traffic scheduling can either be generated by a processing unit within the TSN node or by an external control entity. With the development and proliferation of SDN, future research can develop various event generation techniques based on the centralized SDN control and management. The generated events can trigger various

TSN specified actions, such as frame transmissions, frame dropping, or frame preemption, enabling new applications for SDN control and management. To the best of our knowledge, event triggering methods based on SDN have not yet been investigated in detail, presenting an interesting direction for future research. However, SDN based management of TSN has already proposed and we discuss the applicability of SDN for managing TSN flows in Sec. IV-B4.

While scheduled TSN transmissions provide low latency for prioritized traffic, lower-priority traffic which is also TSN scheduled can be significantly affected by higher priority traffic. In order to advance the understanding of the behaviors of traffic shapers on low-priority TSN traffic, Maixum et al. [114] have analyzed the delay of Ethernet frames that are scheduled according to a hierarchical CBS or a TAS in TSN switches. The evaluations by Maixum et al. indicate that the traffic scheduling for higher priority TSN flows can potentially result in traffic burstiness for lower priority TSN flows, increasing the overall delay for the lower priority traffic. This is because, long bursts of higher priority traffic starve the scheduling opportunities for lower priority frames, leading to the accumulation of low priority traffic. In addition to the static scheduling order, Maixum et al. have also studied the effects of changing the scheduling orders in terms of end-to-end delay for both higher and lower priority levels. The formal worst case delay analysis and simulation results indicate that low priority traffic is severely affected by the scheduled higher priority traffic. Simulations of an automotive use-case indicate a worst case delay for the prioritized traffic of 261 μs , while the worst case delay for low priority traffic is 358 μs .

4) Preemption:

a) *Preemption Mechanism:* Lee et al. [96] have examined the preemption mechanism (see Section III-D3) in conjunction with the TSN timing and synchronization characteristics to estimate the transmission properties of CDT and non-CDT frames. In particular, Lee et al have proposed to insert a special preemption buffer into the transmission selection module that operates across all the different queues at the bottom in Fig. 10 to aid with the preemption mechanism. Lee et al. have then analyzed the timing dynamics of the preemption. Lee et al. note that in actual deployments there are likely timing synchronization errors which impact the frame boundary calculations. Therefore, a minimum safety margin that avoids collisions should be maintained while implementing the preemption mechanism. Lee et al. [96] advocate for a safety margin size of 20 bytes, accounting 5 bytes for an error margin and 15 bytes for synchronization errors. The simulation evaluations justify the impact of the synchronization errors on the safety margin duration and end-to-end delay. Related preliminary preemption analyses have been conducted in [115]

b) *Preemption Effect on Non-CDT:* Preemption prioritizes CDT frame transmissions over the transmission of regular Ethernet frames. Thus, preemption of non-CDT traffic can negatively impact the end-to-end characteristics of non-CDT traffic. In addition, lower priority CDT frames can be preempted by higher priority CDT frames. Hence, the preemption process can impact the end-to-end delay differently for the different priority levels even within the CDT traffic.

Thiele et al. [97] have formulated an analytical model to investigate the implications of the preemption process on the end-to-end delay characteristics of CDT and non-CDT traffic. Thiele et al. have compared standard Ethernet with preemption (IEEE 802.1Q + IEEE 802.3br) and TSN Ethernet with time triggered scheduling and preemption (IEEE 802.1Qbv + IEEE 802.3br) with the baseline of standard Ethernet (IEEE 802.1Q) without preemption. The worst-case end-to-end latency of CDT with preemption was on average 60% lower than for 802.1Q without preemption. Due to the CDT prioritization, the worst-case latency of non-CDT traffic increased up to 6% as compared to the baseline (802.1Q) due to the overhead resulting from the preemption process. Hence, the impact of preemption process of non-CDT traffic is relatively minor as compared to the performance improvements for CDT traffic. Additionally, the latency performance of standard Ethernet with preemption is comparable to that of Ethernet TSN with preemption. Therefore, Thiele et al. [97] suggest that standard Ethernet with preemption could be an alternative to TSN for CDT traffic. Standard Ethernet would be much easier to deploy and manage as than TSN, as TSN requires the design and maintenance of the IEEE 802.1Qbv gate scheduling processes along with time synchronization across the network.

c) *Preemption Analysis and Hardware Implementation:*

Zhou et al. [98] conducted a performance analysis of the frame transmission preemption. In particular, Zhou et al. adapted a standard M/G/1 queueing model to estimate the long run average delay of preemptable and non-preemptable frame traffic and evaluated the frame traffic through simulations. The numerical results from the adapted M/G/1 queueing model and the simulations indicate that preemption is very effective in reducing the frame delays for express non-preemptable traffic relative to preemptable traffic; the average frame delays of the express traffic are one to over three orders of magnitude shorter than for preemptable traffic. Zhou et al. have also provided the VHDL design layout of the transmit unit and receive unit for frame preemption for an FPGA based hardware implementation.

5) *Summary and Lessons Learnt:* Flow control mechanisms ensure that intermediate nodes support the end-to-end behavior of a TSN flow. Traffic shaping controls the frame transmission over the egress port in a TSN switch. Each traffic shaper strives to transmit a frame from a priority queue within the shortest possible deadline while having minimal impact on the transmissions from other queues. A finer resolution of priority levels, i.e., a higher number of priority levels provides increasingly fine control over frame transmissions from multiple queues. As a limiting scenario, an independent queue can be implemented for each individual flow in a TSN node. However, such fine-grained prioritization would require extensive computation and memory resources in each TSN node. To overcome this, virtual queues can be implemented by marking the frames in a single queue, eliminating the need for a number of queues equal to the number of TSN flows. Each marked frame can be scheduled based on the marking value. As low priority flows can potentially face long delays due to resource starvation from the scheduling of high priority flows, dynamic (i.e., changeable) priority values can be assigned to

virtual queues. Dynamic priorities can help prevent prolonged delays for flows that were initially assigned low priority. The priority levels can be dynamically changed based on the wait time or the total transit delay of a frame compared to a predefined threshold. Advanced dynamic priority techniques, such as priority inversion, could be implemented such that the worst-case delay of low priority traffic can be kept within prescribed limits.

D. Flow Integrity

1) *Fault Tolerance*: The AVB task group was mainly introduced to add real-time capabilities to the best effort Ethernet service. Industrial control networks expect more reliable and stricter QoS services as compared to best effort Ethernet network service. Fault tolerance is a critical part of industrial network to ensure the reliability of the network. The general principle for enabling fault tolerance in a network is to introduce redundancy.

Following this general principle, TSN provides fault tolerance through redundancy mechanisms, such as frame replication and elimination as well as path control and reservations, see Section III-E. Kehrer et al. [99] have conducted research on possible fault-tolerance techniques as applied for TSN networks. The main challenges associated with fault tolerance mechanisms in a TSN network are the restoration processes for the end-to-end link failures while preserving the network topology, i.e., without causing any significant break in continuity of network connectivity. To address this, Kehrer et al have compared two approaches: *i*) decoupled stream reservation and redundancy [116], and *ii*) harmonized stream reservation and redundancy (which corresponds to IEEE 802.1CB).

In the decoupling approach, the stream reservation protocol registers and reserves the streams independently of the redundancy requirements. This decoupled approach allows for arbitrary redundancy protocols to be utilized. In contrast, the harmonized approach considers more integrated approach in establishing the reservation and redundancy requirements. More specifically, the IEEE standards approach, the IEEE 802.1Qca stream reservation protocol is coupled with the IEEE 802.1CB frame duplication.

The main pitfall to avoid is to understand the application requirements in terms of flexibility before choosing the redundancy approach. Specific industrial automation networks may have peculiar reliability requirements that may be more flexibly met with the decoupled approach. On the other hand, the decoupled approach has a higher protocol overhead and requires more network bandwidth due to the distributed and independent mechanisms along with the lack of coordination between stream reservation and redundancy, as opposed to the integrated approach.

2) *Summary and Lessons Learnt*: Failure recovery and fault tolerance are key aspects of reliable network design. However, to date there has been only very scant research to address the critical challenges of resource reservation for fault tolerance while considering ULL requirements. Future research has to investigate the wide range of trade-offs and optimizations that arise with reliability through frame replication. For instance, high priority flows could have reservations of dedicated

resources, while low priority flows could share a common reserved resource. The dedicated resources would enable the instantaneous recovery of the high priority TSN flows; albeit, at the expense of a slight reduction of the overall network efficiency due to the redundancy. In the event of failure for a low priority traffic flow, the connection could be reestablished with a new flow path considering that the flows can tolerate delays on the order of the connection reestablishment time. Centralized SDN management can also provide the flexibility of dynamic path computation and resource reallocation in the event of failure. Therefore, the area of flow integrity requires immediate attention from the researchers to design and evaluate the performance in terms of efficient recovery process based on priority.

E. General TSN Research Studies

TSN is being widely adopted in critical small-scale closed automotive and industrial networks to establish reliable ULL end-to-end connections. However, a key TSN limitations is exactly this focus on closed networks, e.g., in-vehicle networks and small-scale robotic networks. The network applications running in robots and in in-vehicle networks often involve significant interactions with external non-TSN networks. Robotic and vehicular network applications require a tight integration with mobility handling procedures by the external network. If advanced network features, such as mobility, are not properly supported in the external network, then the TSN benefits are fundamentally limited to small-scale closed networks. Therefore, smooth interoperability between TSN and different external networks is essential for TSN operation in heterogeneous network scenarios. Ideally, the connectivity between TSN and non-TSN networks should be able to accommodate similar characteristics as TSN to ensure the overall end-to-end connection requirements in heterogeneous deployments.

1) *V2X Communication*: Juho et al. [117] have proposed iTSN, a new methodology for interconnecting multiple TSN networks for large-scale applications. The iTSN methodology utilizes wireless protocols, such as IEEE 802.11p, for the inter-networking between different TSN networks. In particular, the sharing global timing and synchronization information across the interconnected network is important for establishing a common timing platform to support TSN characteristics in the external networks. The iTSN network uses the IEEE 802.11p WAVE short message protocol to share the timing information between different TSN networks. Critical rapid alert messages can be prioritized not only within a given TSN network, but also across multiple interconnecting networks. Thus, the iTSN methodology enables, for instance, vehicular networks to transmit safety critical messages to control nodes, e.g., Road Side Units (RSUs) [118], with delays on the order of microseconds in a heterogeneous deployment. Through the adoption of such reliable inter-connectivity techniques, the vehicle braking safety distance can be achieved in much less (microseconds) than the currently feasible range of milliseconds. Overall, TSN and an interconnecting technique, such as iTSN, can create a communication platform for safe autonomous driving systems.

2) *Network Modeling*: Although TSN standards have received significant attention in networks for automotive driving, a major challenging in network deployment is managing the complexity. As the automotive driving technology progresses, more requirements are imposed on the existing in-vehicle network infrastructure. As the number of sensors increase in an in-vehicle network, the increasing connectivities and bandwidth requirements of the sensors should be correspondingly accommodated in the network planning. However, the dynamic changes in the network requirements for an in-vehicle control system could require a more extensive network infrastructure, resulting in higher expenditures. Considering the complexities of automotive networks, Farzaneh et al. [119] have proposed a framework to analyze the impact of adding new sensors to an existing infrastructure that supports critical applications. In particular, the network configuration that fulfills all the requirements, including newly added sensors, must be dynamically evaluated and implemented. Towards this end, the Farzaneh et al. [119] framework involves a design and verification tool based on a Logic Programming (LP) method to support the reconfiguration and design verification process for an in-vehicle TSN network. The proposed framework consists of comprehensive logical facts and rules from which a user can query the database with the requirements to obtain configurations that satisfy the requirements. A key characteristic of the proposed approach is that the network modeling process considers the most accurate logical facts and rules of the TSN applications and requirements to obtain an efficient configuration and verification process.

3) *TSN Simulation Framework*: Heise et al. [120] have presented the TSimNet simulation framework to facilitate the development and verification of TSN networks. TSimNet was primarily implemented to verify industrial use-cases in TSN networks. The simulation framework is based on OM-NeT++, whereby the non time-based features, such as policy enforcement and preemption are implemented in a modular fashion to increase the flexibility of designing new network mechanism suitable for industrial networks. For instance, the initial evaluation of the simulation framework for frame preemption mechanisms indicates that the end-to-end latency can be increased if the network is not configured in an optimized way for critical functions, such scheduling and traffic shaping. Heise et al. have evaluated the computational cost of the TSimNet framework for various network function simulations, such as policing, recovery, and preemption in terms of CPU and memory requirements. The simulation framework also features Application Specific Interfaces (APIs) for TSN mechanisms that do not require time synchronization, such as stream forwarding, per-stream filtering, as well as frame replication and recovery. APIs can be invoked by the simulation framework through a profile notification. The basic framework modules also include the TSimNet Switch Model, which can identify streams based on MAC, VLAN, and/or IP addresses, while the TSimNet Host Model implements complex functions, such as ingress and egress policy, as well as traffic shaping.

4) *Hardware and Software Design*: Hardware and software component designs to support TSN functions, such as

scheduling, preemption, and time-triggered event generation in TSN nodes require significant engineering and development efforts. Hardware implementations are highly efficient in terms of computational resource utilization and execution latency but result in rigid architectures that are difficult to adapt to new application requirements. On the other hand, software implementations can flexibly adapt to new application requirements, but can overload CPUs due to the softwarization of network functions, such as time-triggered scheduling and hardware virtualization.

Gross et al. [121] have presented a TSN node architecture design where the time-sensitive and computationally intensive network functions are implemented in dedicated hardware modules to reduce the CPU load. The proposed hardware/software co-design approach flexibly allocates network function to be executed completely in hardware, completely in software, or in both hardware and software based on the dynamic load. The flexible allocation is limited to network functions that independently scale with the timing requirements, such as the synchronization protocol. More specifically, Gross et al. have considered time-triggered transmissions, frame reception and timestamping, and clock synchronization. The hardware modules can produce the time-triggered events nearly jitter free, implement frame reception and timestamping in real-time, and synchronize clocks with a high degree of precision. Thus, the hardware modules improve the overall TSN node performance compared to a software-only implementation. The performance evaluations from a prototype implementation based on a Virtex-6 FPGA showed a significant reduction in the CPU load compared to a software-only implementation. Additionally, the precision of the time-triggered event generation in the hardware implementation was improved by a factor of ten compared to software triggered events.

5) *Summary and Lessons Learnt*: The general aspects of TSN that determine the overall success of TSN designs and implementations are the inter-interopability with heterogeneous network architectures, such as LAN, WAN and core network. Most of the research on TSN to date has focused on in-vehicle networks which are independent and isolated from external networks. Another limitation of the TSN research field is the lack of a simulation framework that encompasses large-scale heterogeneous network architectures. Valid use cases that include both localized and external network interactions, such as automotive driving, should be created and considered in benchmark evaluations. Currently, the general use-case in most TSN research studies is an in-vehicle network supporting on-board sensor connectivity and audio/video transmission for infotainment. Future custom TSN simulation frameworks should be based on networks that support next-generation applications with localized and external network interactions, such as automotive driving. Similarly, the SDN based TSN management could exploit hierarchical controller designs to extend the management from localized networks, such as in-vehicle networks, to external networks, such as vehicle-to-any (V2X) networks.

F. Discussion on TSN Research Efforts

The TSN network infrastructure and protocols have to support provide features, such as bounded end-to-end delay and reliability, to support basic features related to critical applications of IoT, medical, automotive driving, and smart homes. TSN based solutions for addressing the requirements of these applications result in a complex network infrastructures supporting various protocols. Hence, simplified TSN network management mechanisms are essential to reduce the complexity while achieving the critical needs of the ULL applications.

The deterministic TSN network behavior has so far been generally applied to a closed network, i.e., a network spanning only the scope of a particular application, for instance, in-vehicle networks. However, the connectivity to external networks, such as cellular and WLAN networks, enhances the capabilities of TSN networks. For instance, in automotive driving, the application requirements can be controlled by weather data from the cloud or by sharing information with a neighboring TSN in-vehicle network. Therefore, reliable, secure, and low-latency communication between multiple TSN networks is essential to support a wide range of future applications. The lack of TSN standards for connecting and communicating with external TSN and non-TSN networks is impeding the research activities in inter-operating networks and needs to be urgently addressed. In summary, we identify the following main future design requirements for TSN research:

- i) Support for a wide range of applications spanning from time-sensitive to delay tolerant applications with flow level scheduling capabilities.
- ii) Connectivity between multiple closed TSN architectures.
- iii) Flexible and dynamic priority allocation to ensure bounded end-to-end latency for lower priority traffic.
- iv) Adoption of SDN for the centralized management of TSN functions with a global network perspective.
- v) Efficient timing information sharing and accurate clock design through self-estimation and correction of local clock skewness.
- vi) Computationally efficient hardware and software designs.

Generally, TDM can enforce a deterministic (100%) latency bound, but the TDM average delay is typically somewhat higher than the statistical multiplexing average delay (and TDM has low utilization for bursty traffic). With proper admission control, statistical multiplexing can provide statistical guarantees for latency bounds, e.g., the probability for exceeding the delay bound can be very low, e.g., less than 10^{-4} probability that the delay bound is violated. These rare occurrences of violating the delay bound “buy” usually much higher utilization (throughput) than TDM and lower average delay (for bursty data traffic) [122]–[126]. An interesting future research direction is to examine the trade-offs between deterministic and probabilistic delay bound assurances in detail for ULL traffic served with TSN mechanisms.

V. DETNET STANDARDIZATION

In this section, we present a detailed overview of the current standardization of the IETF Deterministic Networking (DetNet) WG. The IETF DetNet WG collaborates with the

IEEE 802.1 TSN TG to define a common architecture for layers 2 and 3, whereby the TSN TG focuses on layer 2 bridged networks and the DetNet WG focuses on layer 3 routed segments. Similar to the TSN goals, DetNet aims to support deterministic worst-case bounds on latency, packet delay variation (jitter), and extremely low/zero packet loss, regardless of the number of flows and overall load in the network. Moreover, both TSN and DetNet strive for high reliability and redundancy over disjoint paths targeted towards IACS real-time applications.

The charter of the DetNet WG is to specify an overall architecture that standardizes the data plane and the Operations, Administration, and Maintenance (OAM) for layer 3 ULL support. This charter includes the time synchronization, management, control, and security operations that enable multi-hop routing as well as automatic or manual and dynamic centralized or distributed configuration, and multi-path forwarding. In general, DetNet focuses on extending the TSN data and control plane into the layer 3 domain, thus expanding the scope of TSN beyond LANs.

Since the DetNet WG has only been established recently (started in October, 2014, and became a WG in October, 2015), no IETF RFCs exist yet. However, at the time of writing this article, several IETF drafts have become available and will be covered in the following subsections to provide a comprehensive overview of the ongoing IETF DetNet standardizations.

A. Flow Concept

Similar to the TSN TG, DetNet flows are specified by their QoS classes. DetNet defines each flow’s QoS by 1) the maximum and minimum end-to-end latency, and 2) the packet loss probability requirements [127]. DetNet strives to transport unicast and multicast ULL data flows for real-time applications with extremely low packet loss. In essence, DetNet emulates point-to-point links over a packet switched network, where each link can be shared between multiple DetNet and non-DetNet flows, each with varying flow requirements and properties. A key aspect of DetNet flow control and management is ensuring that non-DetNet flows have no influence on DetNet flows regardless of the network load. Maintaining each DetNet flow’s QoS is achieved through the mechanisms surveyed in this section.

1) *DetNet Flow Types*: Before introducing the DetNet flow types, we first give a brief overview of two main layers of the DetNet architecture stack model. The DetNet Transport Layer has an option to provide congestion protection (see Section V-D). The DetNet Service Layer provides service protection, e.g., through flow duplication (see Section V-E). Four main DetNet flow types have been identified [127]:

- 1) **App-flow**: The native data flow between the source and destination end systems within a DetNet enabled network.
- 2) **DetNet-t-flow**: The specific data flow format bound to the transport layer within a DetNet enabled network. The DetNet-t-flow contains the specific data attributes that provide features for congestion protection.
- 3) **DetNet-s-flow**: The specific data flow format bound to the service layer within a DetNet enabled network. The

DetNet Standardizations, Sec. V

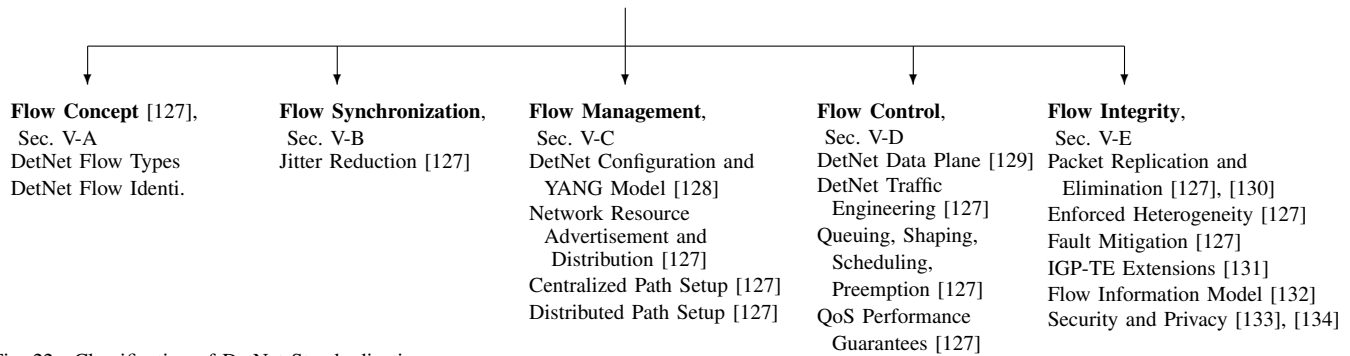

Fig. 22. Classification of DetNet Standardization.

DetNet-s-flow contains the specific data attributes that provide features for replication and elimination functions supporting service protection.

- 4) **DetNet-st-flow**: The specific data flow format that is bound to both the transport and service layers within a DetNet enabled network. The DetNet-st-flow signals the appropriate forwarding function utilizing both the service and transport layer attributes.

2) *DetNet Flow Identification*: In contrast to a conventional strictly layered network architecture, DetNet nodes intentionally violate “layering norms” so that lower layers can detect and become aware of higher layer flow types. This awareness of the higher layer flow types helps to provide specific queuing, shaping, and forwarding services as flows are transported across multiple technology domains. However, violating the layering norms creates new layering and re-layering complexities. Therefore, DetNet must provide a way to easily and correctly identify flows and their associated types. DetNet is architected to allow nodes within the network data plane to distinguish DetNet flows based on the flow ID and DetNet Control Word (CW), i.e., sequencing information, appended in the packet header, whereby the CW is used for replication and elimination purposes.

To achieve accurate flow detection and identification, the flow attribute mapping between layers and across technology domains has to be standardized. For each forwarding of a DetNet flow between different technology domains, the relay node (i.e., router) needs to acquire upper layer information related to the flow type and corresponding attributes. For example, when a DetNet flow is forwarded between two Label Switching Routers (LSRs) that interconnect different Layer 2 bridged domains, then at each domain boundary, the higher layer flow information is passed down to the node for correct forwarding. Three main forwarding methods are considered in DetNet: 1) IP routing, 2) MPLS label switching, and 3) Ethernet bridging. For forwarding across technology domains, each DetNet App-flow packet is appended or encapsulated with multiple flow-IDs (IP, MPLS, or Ethernet). This enables DetNet routing and forwarding between different and disparate IP and non-IP networks, essentially providing network interoperability.

3) *Summary and Lessons Learned*: Although no implementation specifications have been released for DetNet flows, the DetNet WG have outlined a draft specification architecture for defining the key aspects and attributes related to DetNet flows

and DetNet architecture, including the main mechanisms for realizing DetNet flow types and identification methods.

B. Flow Synchronization

The main objective of DetNet is to expand the TSN capabilities to layer 3 routing segments. DetNet relies heavily on the services of the IEEE TSN TG mechanisms. Flow synchronization with respect to the DetNet flow architectural model has not been specifically addressed in [127]. Therefore, it is likely that DetNet will ensure timing synchronization between DetNet capable network entities (bridges, routers, and end systems) through various existing synchronization techniques and profiles, e.g., IEEE 802.1AS and IEEE 1588v2.

1) *Jitter Reduction*: Applications in the mission critical latency traffic class require extremely low delay variations (jitter). High jitter can lead to packet loss downstream and in the worst-case, loss of human life in factory networks. DetNet strives to convergence non-IP networks into a common network infrastructure [127]. DetNet strives to support minimal jitter by bounding the minimum and maximum latency, which is challenging in large scale packet switched networks. DetNet specifies jitter reduction through two main principles: 1) sub-microsecond time synchronization between network entities, and 2) time-of-execution fields embedded within the application packets [127].

2) *Summary and Lessons Learned*: While no specific specifications regarding time synchronization for DetNet network devices exist, the DetNet WG have overall hinted at using other Standardization Development Organization’s (SDO), e.g., IEEE TSN’s 802.1AS III-B, methods.

C. Flow Management

Flow management describes and specifies the mechanisms for discovering and configuring node capabilities.

1) *DetNet Configuration and YANG Model*: In order for DetNet to enable seamless configuration and reconfiguration across various DetNet enabled network entities, a uniform and scalable configuration model needs to be defined. The Internet draft [128] defines distributed, centralized, and hybrid configuration models, related attributes, and the YANG model for DetNet.

a) *DetNet Configuration Model*: Three configuration models have been introduced [128]: fully distributed, fully centralized, and hybrid. For a fully distributed configuration model, UNI information is sent over a DetNet UNI protocol, i.e., sent using the flow information model discussed in Section V-E. A distributed DetNet control plane propagates the UNI and configuration information to each data plane entity. In the centralized configuration model, the CUC sends the UNI information to the CNC, similar to the IEEE 802.1Qcc centralized configuration model, see Section III-C. For the hybrid configuration approach, a combination of distributed and centralized protocols within the control planes are used to coordinate configuration information. The fully distributed and hybrid configuration model are not covered in [128] and are left for future work.

b) *DetNet Configuration Attributes*: Depending on the configuration model and control plane associated protocols (i.e., IGP and RSVP-TE, or CNC and CUC), different configuration parameters or attributes are used. The following main attributes have been defined for the centralized configuration model [128]:

- 1) **DetNet Topology Attributes** specify topology related attributes, such as the node type, whether it is PREF capable or not, and the queueing management algorithm.
- 2) **DetNet Path Configuration Attributes** specify the networked path related attributes, such as the constraints (required min/max latency), and explicit routes using a PCE (with PREF).
- 3) **DetNet Flow Configuration Attributes** specify the DetNet flow attributes, such as the flow ID, priority, traffic specification, and encapsulation method.
- 4) **DetNet Status Attributes** specify the flow status feedback attributes, such as the flow performance (delay, loss, policing/filtering), and the PREF status.

DetNet YANG Model: Similar to IEEE 802.1Qcp, a DetNet YANG model has been defined [128] for the centralized configuration model to convey network configuration parameters.

2) *Network Resource Advertisement and Distribution*: To supplement the DetNet Congestion Protection mechanisms (which are defined for DetNet as flow control mechanisms, including shaping, scheduling, and preemption), and to accurately provision network resources for DetNet flows, each node (or central controller in a centralized setup) needs to share and alert nearby networks of its (end system and/or transit node) capabilities [127] including:

- 1) System capabilities, e.g., shaping and queuing algorithm used, buffer information, and worst-case forwarding delay
- 2) Dynamic state of the node's DetNet resources
- 3) Neighbor nodes and the properties of their relationships, i.e., the properties of the links connecting them, e.g., length and bandwidth

How this information is carried over the control plane and the implementation specification is not available or standardized yet. However, with this information, PCE's automatic path installation (distributed or centralized) can handle each DetNet

flow's QoS requirement assuming that enough resources are available.

3) *Centralized Path Setup*: Similar to IEEE TSN's centralized management model (802.1Qcc), DetNet's centralized path setup leverages PCEs and packet based IP or non-IP network information dissemination to enable global and per-flow optimization across the DetNet enabled network. The DetNet WG [127] has addressed several related key issues, such as the responsibility of the installation of the received path computation (whether by the Network Management Entity (NME) or end systems), and how a path is set up, i.e., through direct interactions between the forwarding devices and the PCEs, or by installing the path on one end of the path through source-routing or explicit-routing information [127].

4) *Distributed Path Setup*: The DetNet WG has developed initial design specifications for a distributed path setup (similar to the 802.1Qat, 802.1Qca, and MRP signaling protocols) utilizing Interior-Gateway Protocol Traffic Engineering (IGP-TE) signaling protocols, defined in Section V-D, e.g., MPLS-TE, RSVP-TE, OSPF-TE, and ISIS-TE [127]. A key issue is how the interactions and integration between layer 2 sub-network peer protocols for TE and path installation will be defined, since significant work has been accomplished by the IEEE 802.1 TSN TG regarding distributed and centralized protocols on path and multi-path setup and signaling protocols.

5) *Summary and Lessons Learned*: Before controlling a DetNet flow, the node's capabilities need to be distributed to the PCE in the control plane. To efficiently disseminate the node capability information, a configuration and YANG model need to be standardized to allow for dynamic reconfiguration, management, and status collection in large scale IP/non-IP based networks.

D. Flow Control

While most control functions for DetNet flows follow the same principles used for IEEE TSN TG deterministic flows, key integration mechanisms and several differences are outlined as follows.

1) *DetNet Data Plane*: To better understand how DetNet services operate, we first provide a brief overview of the DetNet data plane. A DetNet capable network is composed of interconnected end systems, edge nodes, and relay nodes [127]. Transit nodes (e.g., routers or bridges) are used to interconnect DetNet-aware nodes, but are not DetNet-aware themselves. Transit nodes view linked DetNet nodes as end points. DetNet is divided into two main layers: 1) the DetNet service layer, and 2) the transport layer. DetNets can have several hierarchical DetNet topologies where each lower layer services the higher layer. Furthermore, DetNet nodes (end systems and intermediary nodes) are inter-connected to form sub-networks. These sub-networks, e.g., Layer 2 networks, can support DetNet traffic through compatible services, e.g., IEEE 802.1 TSN or point-to-point Optical Transport Network (OTN) service in 5G systems [127].

There are currently various protocol and technology options under consideration for DetNet transport protocols and data encapsulation. Table. II provides an overview of these protocol candidates for the DetNet service and transport layers,

including a brief description of each protocol and the latency impact on a DetNet flow. Although no official solution has emerged yet for the DetNet data plane encapsulation at the network layer, a couple of proposals exist to tackle this problem. According to Korhonen et al. [129], two of the most prominent deployment candidates for the data plane protocols are either UDP/TCP over native-IP (IPv6) or PseudoWire-based (PW) [135] data plane over an MPLS Packet Switched Network (PSN). While many options exist for DetNet data encapsulation, it is imperative to test and discern the corresponding performance overhead for each proposed DetNet node's packet manipulation technique.

2) *DetNet Traffic Engineering*: The IETF Traffic Engineering Architecture and Signaling (TEAS) WG considers Traffic Engineering (IE) architectures for packet and non-packet networks [138], essentially allowing network operators to control traffic traversing their networks. Since DetNet operates with explicit paths, the DetNet WG has drafted a TE architectural design for DetNet utilizing similar methodology as the Software Defined Networking (SDN) paradigm. The DetNet WG defines three main planes [127]: 1) the (user) application plane, 2) the control plane, 3) the network plane. The network plane conforms with the specification of the Internet Research Task Force (IRTF) RFC 7426 [139] that details the structure and architecture of the SDN networking paradigm. This SDN approach shares similarities with the IEEE TSN's 802.1Qcc management scheme and centralized SDN approach.

a) *Application Plane*: The collection of applications and services that define the network behavior constitute the application plane. For example, network services, such as network topology discovery, network provisioning, and path reservation, are all part of network applications that can be utilized through the application plane and can be accessed by a user-application interface or by other services through the service interface [127]. Moreover, the DetNet WG has defined a user agent application for passing DetNet service requests from the application plane via an abstraction Flow Management Entity (FME) to the network plane. The management interface handles the negotiation of flows between end systems, where requested flows are represented by their corresponding traffic specification (Tspec), i.e., the flow characteristics. The applications in the application plane communicate via the service interface with the entities in the control plane

b) *Control Plane*: The collection of functions responsible for controlling (e.g., flow installation and processing in the forwarding plane) and managing (e.g., monitoring, configuring, and maintaining) network devices constitute the control plane. The DetNet TE architecture utilizes the Common Control and Measurement Plane (CCAMP) standardized by the IETF CCAMP WG, where the aggregate control plane, i.e., the control and management planes, is distinctly split between management and measurement entities within the control plane. Additionally, the control plane leverages PCEs and NMEs. PCEs are considered the core of the control plane that, when given the relevant information through the network interface, can compute the appropriate deterministic path that is installed in the network plane devices.

c) *Network Plane*: The aggregate network plane constitutes the operational (control), forwarding (data), and parts of the applications plane aspects under the RFC 7426 standard. The network plane interconnects all the Network Interface Cards (NICs) in the end systems and intermediate nodes (i.e., IP hosts and routers/switches). Additionally, UNIs and Network-to-Network (NNI) interfaces are used for TE path reservation purposes. A network interface is used to enable communication between the network plane and the control plane, whereby the control plane can describe and install the physical topology and resources in the network plane.

In general, this DetNet TE architecture envisions a highly scalable, programmable, and uPnP scheme, where network functionality and configurations are easily implemented and extended.

3) *Queuing, Shaping, Scheduling, and Preemption*: While identifying the appropriate data and control plane solutions is imperative for correct operations in DetNet environments, flow control principles (e.g., queuing, shaping, scheduling, and preemption) must be defined to enable DetNet flows to achieve deterministic bounded latency and packet loss [127]. Flow control usually involves network resource reservation, i.e., bandwidth and buffer space allocation. However, a key aspect of reservation is to standardize reservations across multi-vendor networks, such that any latency in one system that differs in another system is accounted for and handled appropriately.

DetNet flow control will accordingly leverage the IEEE 802.1 TSN queuing and enhanced transmission and traffic shaping techniques surveyed in Section III-D. These TSN mechanisms include the credit-based shaper (802.1Q Section 34), the time-gated or time-aware transmission selection (802.1Qbv), the cyclic queuing and forwarding or peristaltic shaper (802.1Qch), the asynchronous traffic shaper (802.1Qcr), and the preemption within bridges (802.1Qbu and 802.3br). These techniques (except for packet preemption) can relatively easily be implemented in DetNet networks and are a focus of collaboration between the DetNet WG and the TSN TG.

4) *QoS Performance Guarantees between Synchronous and Asynchronous DetNet Flows*: DetNet flows, similar to TSN flows, can be transmitted synchronously or asynchronously. Each method has advantages and disadvantages with respect to congestion protection. Synchronous DetNet flows traverse DetNet nodes that are closely time synchronized (e.g., better than one microsecond accuracy). The time synchronized DetNet nodes can transmit DetNet flows belonging to different traffic classes in a coordinated timely fashion, i.e., based on repeated periodic schedules that are synchronized between the DetNet nodes. This synchronized transmission follows the same principles as the TSN time-aware gated mechanism (802.1Qbv) where buffers are shared based on the coordinated time among the nodes. A main disadvantage of synchronous transmission is that there is a trade-off between fine-grained time synchronized schedules and the required network resource allocation [127].

In contrast, asynchronous DetNet flows are relayed based on the judgment of a given individual node. More specifically, the node assumes the worst-case latency interference among the queued DetNet flows and characterizes flows based on three

TABLE II
CANDIDATE PROTOCOLS FOR DETNET SERVICE AND TRANSPORT LAYERS

Layer	Candidate Protocol	Description	Latency Imp.
Service	PseudoWire (PW)	Emulates networking services across packet switched networks (PSNs), delivers bare minimum network service functionality on physical infrastructure with some degree of fidelity.	Moderate
	Real-Time Trans. Prot. (RTP)	Provides management functionality for applications to manage real-time transmission of multimedia data, with RTP Control Prot. (RTCP).	Low
	User Datagram Prot. (UDP)	Connection-less transmission of packets with low overhead, though no feedback services provided.	Low
	Generic Rout. Encap. (GRE)	Tunneling protocol that encapsulates arbitrary network layer protocol over another network layer protocol, e.g., IPv6 over IPv4.	Moderate
	Layer 2 Tunn. Prot. (L2TP)	Tunneling protocol that supports Virtual Private Network (VPN) over an IP network, e.g. FrameRelay, Ethernet, and ATM.	Moderate
	Virt. Exten. LAN (VXLAN)	Provides encapsulation service on a overlay network over L3, used mainly for virtualization functionality extending and improving VLAN functionality.	Moderate
	Eth. Virtual Priv. Net. (EVPN)	Provides enhanced services for Ethernet based multipoint to multipoint communication in addition to the Virtual Private LAN Service (VPLS [136]) solution.	Moderate
Transport	Internet Prot. Ver. 4 (IPv4)	Connection-less protocol for use in PSNs supporting best-effort services.	Moderate
	Internet Prot. Ver. 6 (IPv6)	Similar to IPv4 but with a larger address space, includes a few improvements and simplifications.	Moderate
	Multi-Prot. Label Swit. Label Swit. Path (MPLS LSP)	Routing prot. that forwards labeled packets that define the source-destination paths without routing table look-ups. Instead, at each hop, the label is used as an index and a new label is generated and sent along the packet to the next hop.	Moderate
	Bit Ind. Explicit Rep. (BIER)	An alternative multicast forwarding technique that does not use per-flow forwarding entries. Instead, a BIER header is used to identify the packet's egress nodes in the BIER domain. A bit string that is set at each ingress node is used, and the flow is replicated at each egress node represented by the bit string.	High
	BIER-Traffic Engin. (BIER-TE)	Operates similarly to BIER but does not require an Interior Gateway Protocol. TE by explicit hop-by-hop forwarding and loose hop forwarding [137] of packets is supported.	High

properties:

- 1) The maximum packet size of each DetNet flow
- 2) The observational interval, i.e., the time a DetNet flow is occupying the resource
- 3) The maximum number of transmissions during the observational interval

Based on the DetNet packet properties and the various header fields resulting from the employed protocol stack, the transmission control limits the DetNet flow's transmission opportunities to a prescribed number of bit times per observational interval. DetNet's design goal of deterministic operation with extremely low packet loss dictates that each flow must be regulated in terms of consumed bandwidth. Furthermore, any unused bandwidth can be allocated to non-DetNet flows, and not to any other DetNet flow since each DetNet flow has its own resource reservation allowance.

5) *Summary and Lessons Learned*: DetNet specifies the control parameters and properties that can integrate with lower layer L2 network transport functionality. These specifications enable deterministic bounds on QoS flow requirements across L3 networks that consist of multiple L2 network segments. DetNet defines a high-level TE architecture that follows an SDN approach, where key concepts and functions that control and manage DetNet flows and the relationships between the planes are defined and specified. This allows users and operators to easily control, measure, and manage flows dynamically

while introducing fast recovery and deterministic bounds on QoS parameters.

E. Flow Integrity

DetNet flow integrity follows similar principles and methods used in IEEE TSN standards and recommended practices. However, some key differences include terminology, L2/L3 integration, and security/privacy considerations.

1) *Packet Replication and Elimination Function*: The Packet Replication and Elimination Function (PREF) shares several similarities with the TSN TG's 802.1CB standard and is derived from IETF's HSR and PRP mechanisms. PREF operates in the DetNet service layer with three main functions [127]:

a) *Packet Sequencing Information*: Packet sequencing adds sequence numbers or time-stamps to each packet belonging to a DetNet flow once. The sequence numbers are used to identify the duplicates if two or more flows converge at a transit or relay node. Moreover, these sequence numbers can be used to detect packet loss and/or reordering.

b) *Replication Function*: Flows are replicated at the source, i.e., with explicit source routes, whereby a DetNet stream is forwarded on two disjoint paths directed to the same destination.

c) *Elimination Function*: Flow elimination is performed at any node in the path with the intent of saving network

resources for other flows further downstream. However, most commonly, the elimination point is at the edge of the DetNet network, near or on the receiver end system. The receiving port selectively combines the replicated flows and performs packet-by-packet selection of which to discard based on the packet sequence number.

PREF is a proactive measure to reduce or even nullify packet loss. However, the PREF replication mechanism needs at least two disjoint paths to ensure reliability. Therefore, in an effort to enable PREF over networks lacking disjoint paths, Huang et al. [130] defined a single-path PREF function. The single-path PREF function does not replicate the DetNet flow over multiple paths; instead, it uses the same path as the original flow. Therefore, only the terminating or edge node has to apply PREF on the flow. The main rationale behind using such a technique is that if parts of a flow on the same path is corrupted or lost, then the replicated flow can cross-check and rebuild the original flow's corrupted or lost packets, essentially performing error correction and remediation. Since more packets are sent on the same link for a single flow than usual, more bandwidth is needed to carry such information within the same bounded delay. Therefore, the technique is mainly used for applications that require low-rate bursty or constant traffic services, e.g., blockchain and IoT constrained protocols.

2) *Enforced Heterogeneity*: Similar to its TSN counterpart, DetNet enforces bandwidth discrimination between DetNet and non-DetNet flows. The DetNet network dedicates 75% of the available bandwidth to DetNet flows. However, to keep bandwidth utilization high, any bandwidth that has been reserved for DetNet flows, but is not utilized can be allocated to non-DetNet flows (though not to other DetNet flows). Thus, DetNet's architectural model ensures proper coexistence between differentiated services and applications [127]. Additionally, DetNet flows are transmitted in such a way that ensures non-DetNet flows are not starved, i.e., given transmission opportunities. Moreover, some flow control properties from Section V-D are employed so as to guarantee the highest priority non-DetNet flows a bounded worst-case latency at any given hop.

3) *Fault Mitigation*: In addition to the flow replication and bandwidth discrimination, DetNet networks are designed with robustness targeted towards real-time systems that reduces the chances of a variety of possible failures. One of the key mechanisms in reducing any disruption for DetNet flows is applying filters and policies, similar to IEEE 802.1Qci (PSFP), that detect misbehaving flows and can flag flows that exceed a prescribed traffic volume [127]. Furthermore, DetNet fault mitigation mechanisms can take actions according to predefined rules, such as discarding packets, shutting down interfaces, or entirely dropping the DetNet flow. The filters and policers techniques prevent rogue flows from degrading the performance of conformant DetNet flows.

4) *IGP-TE Extensions for DetNet Networks*: To effectively utilize DetNet techniques, i.e., explicit routes, congestion and resource protection, important network information, such as node capabilities, available resources, device performance, needs to be communicated to and processed at the control

entities [131]. The DetNet WG utilizes a PCE where the necessary network information is fed as input, and the PCE can effectively compute a path that satisfies the QoS requirements of the DetNet flow. Additionally, some information can be distributed and collected using already defined TE metric extensions for OSPF and ISIS protocols.

Key parameters, including the employed congestion control method, the available DetNet bandwidth, as well as the minimum and maximum queuing delay are embedded in sub-TLVs [131]. Based on these parameters, OSPF and ISIS can accurately compute the path according to the perceived network topology and status.

5) *Flow Information Model*: In order to simplify implementation and to enable DetNet services to operate on Layers 2 and 3, a DetNet flow information model must be defined to describe the flow characteristics such that nodes within L2 or L3 provide support flows properly between the sender and receiver end systems [132]. Farkas et al. [132] has specified a DetNet flow and service information model based on the data model described in IEEE 802.1Qcc's centralized management and reservation standard.

6) *Security and Privacy Considerations*: While ensuring bounded worst-case latency and zero packet loss are the main goals of DetNet, security and privacy concerns are also important [127]. DetNet is envisaged as a converged network that integrates the IT and OT domains. Technologies that once were considered applications operating in isolation or with very limited Internet connectivity, e.g., cyber-physical systems (CPS) applications, such as the power grid as well industrial and building control, are now interconnected [140]. The interconnection makes these CPS applications susceptible to external attacks and threats that are widespread on consumer IT-based networks [133]. Since any potential attack can be fatal and cost considerable damage, CPS applications present attractive targets for cyber-attackers.

Mizrahi et al. [133] have defined a threat model and analyzed the threat impact and mitigation for the DetNet architecture and DetNet enabled network. The attacks that are associated with several use cases have been detailed in [134]. Since security models and threat analysis are outside the scope of this paper, we only briefly note that the three main DetNet security aspects are (i) protection of the signaling or control protocol, (ii) authentication and authorization of the physical controlling systems, and (iii) identification and shaping of DetNet flows and protection from spoofing and Man-in-the-Middle (MITM) attacks and refer to [133] for further details.

7) *Summary and Lessons Learned*: The integrity and protection of DetNet flows against possible failures, including intentional and non-intentional failures, is imperative for the envisaged convergence of the IT and OT domains, i.e., the linking of CPSs with the consumer/enterprise systems. Furthermore, the secure information dissemination across DetNet enabled networks, including access control and authentication, must be addressed.

Future work should examine whether it would be feasible to ensure reliability without explicit packet replication. The underlying idea of replication is to proactively replicate packets for mission-critical applications, since ULL packets

become stale if retransmissions are used. Therefore, replication is the easiest way to achieve reliability, albeit at the added cost of bandwidth. State of the art Ethernet technology has now been standardized to allow up to 400 Gbps bandwidth. Hence, there should be enough bandwidth for replication for low to moderate proportions of mission-critical applications. If mission-critical applications account for large portions of the applications, then alternative reliability mechanisms based on low-latency coding, e.g., low-latency network coding [141]–[143], may be required

F. Discussion on DetNet Standardization Efforts

DetNet strives to extend and integrate L2 techniques and mechanisms with the aim of enabling end-to-end deterministic flows over bridges and routers, i.e., DetNet L3 nodes beyond the LAN boundaries. DetNet is envisioned to run over converged packet switched networks, in particular IP-based networks. Essentially, the DetNet architecture provides deterministic properties, e.g. bounded worst-case latency, jitter, and packet loss, with the goal of IT and OT convergence requiring L2 and L3 capabilities.

The DetNet WG has so far focused mainly on flow management, Sec. V-C, and flow integrity, Sec. V-E. The DetNet specifications to date provide correct end-to-end navigation and encapsulation, including the DetNet data plane and overall DetNet architecture utilizing stable well-known standards, i.e., IETF RFCs and IEEE standards. For instance, DetNet employs PCE for path computation, HSR and PRP for path redundancy, as well as SDN and centralized approach to the overall DetNet.

VI. DETERMINISTIC NETWORKING (DETNET) RESEARCH EFFORTS

The IETF DetNet standardizations define procedures to enable deterministic Layer 3 data paths, which can operate over IEEE TSN Layer 2 bridged networks. The data paths defined by DetNet standards are capable of supporting bounded characteristics for the path, such as bounded end-to-end latency, packet loss, packet delay variation (i.e., jitter), and high reliability.

A. Flow Control: Scheduling

An important aspect of the deterministic characteristics of the packet flow is the centralized network wide scheduling. The centralized network wide scheduling has already been adopted by many low-latency end-to-end connectivity technologies, such as MultiProtocol Label Switching (MPLS). In case of MPLS, the Path Computing Element (PCE) is a centralized network entity that computes the optimal end-to-end path based on global topology information. The PCE also agrees with the principles of SDN, where all the network control decisions are centralized. Therefore, the PCE can achieve the characteristics of DetNet. Alternatively, advanced wireless protocols, especially for industrial applications that require deterministic characteristics, such as ISA100.11a and wireless HART, already use centralized routing mechanisms [144].

Adopting wired technologies, such as DetNet, to wireless networks poses challenges due to the possibility of hidden

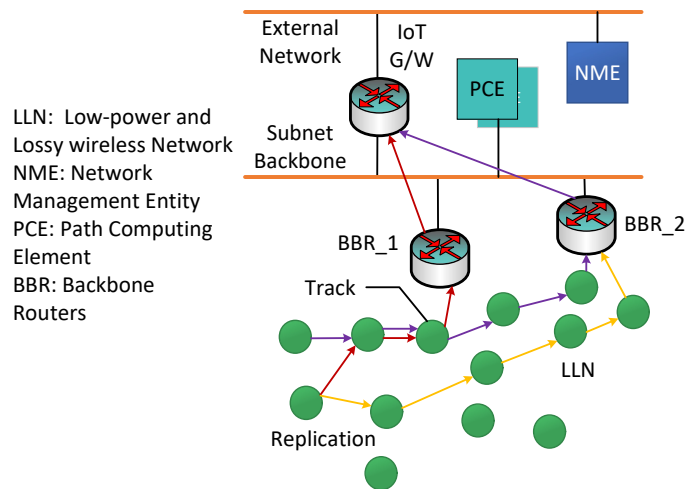

Fig. 23. IPv6 Time Slotted Channel Hopping (6TiSCH) Architecture [145]: Software Defined Networking (SDN) based applications for Deterministic Networking (DetNet) include the Path Computing Element (PCE) for centralized computing of paths supporting frame replication for reliability in low-power and lossy networks.

and exposed nodes. Additionally, the wireless node mobility makes it more complicated to track the delay characteristics. As a result, for wireless technologies supporting DetNet, a promising method for enabling determinism is by scheduling all transmissions through a centralized decision entity. Time Slotted Channel Hopping (TSCH) is a physical layer access technique where multiple devices access the physical resources in terms of time and frequency slots [146]. However, every subsequent physical layer access over the same channel hops to a different frequency slot to achieve independence from interference and jamming. TSCH has been widely adopted for IoT access methods [147] because of its simplicity and resilience to interference [148]. Moreover, IoT wireless devices have widely adopted IPv6 as their default IP layer. 6TiSCH is a scheduling mechanism [149] based on TSCH supporting IPv6 to achieve DetNet characteristics. Thumbert et al. [145] have identified the challenges associated with centralized scheduling in 6TiSCH based on SDN to design end-to-end low latency connectivity. The Path Computing Element (PCE) in the 6TiSCH architecture conducts the centralized monitoring and scheduling management of a TSCH network. The PCE also interacts with the Network Management Entity (NME) to compute the optimal allocations and to assign the transmission resources to the devices. The challenges in applying DetNet for 6TiSCH include dynamic network topology changes and the corresponding run-time modifications of the network resources in response to network topology changes. Additionally, the traffic classification should be uniformly supported between low power wireless links and wired networks.

1) *Summary and Lessons Learnt:* There are many critical IoT applications that depend on reliable communication connectivity, such as health care and automotive applications. DetNet offers an option to enable a reliable end-to-end connection. However, applying the DetNet properties to wireless networks, especially for the IoT applications [147], requires a generic support for topology changes and the link reliability

must be ensured. This is necessary because of the wireless node mobility, whereby a device can physically change its position. The position change can affect the wireless link characteristics, requiring a dynamic network reconfiguration to ensure optimal network behavior. Therefore, in addition to the PCE and Network Management Entity (NME) to track the network characteristics, an important requirement for mobile wireless networks is to track the wireless node characteristics to enable the dynamic adaptation to changes in the wireless properties. However, the tracking and dynamic network reconfiguration can potentially cause network overhead and affect the overall latency and efficiency. Hence, incorporating DetNet into wireless networks requires careful consideration of mitigation techniques for addressing the wireless network challenges while keeping overheads low.

B. Flow Integrity

Industrial applications require determinism, i.e., a bounded and deterministic delay value, along with reductions in the end-to-end packet latency. Towards this end, Armas et al. [150] have presented a path diversity mechanism with packet replication to study the DetNet properties. Armas et al. have conducted a comprehensive performance evaluation to understand the influence of the number of nodes and the number of replications on the energy consumption and the end-to-end packet delay. Armas et al. implemented a centralized scheduler based on SDN principles in the DetNet architecture framework to compute the disjoint paths and to apply the flow rules on networks with up to 80 nodes. The packet loss over the network was evaluated through simulations. The results indicated that with a packet replication factor of 1, where each packet is duplicated once, the packet loss was reduced by 90% on average, showing the potential of packet replication. As the packet replication factor was further increased, the packet loss was completely eliminated. For a given network deployment, the complete packet loss elimination can be achieved with some combination of a degree of disjoint paths and a packet replication factor; any additional replication would then waste resources. The energy consumption almost doubles (is ~ 1.863 times higher) for a packet replication factor of 1, while the packet replication factor 4 increases the energy consumption by almost 3 times (~ 2.914), showing significant energy consumption increases due to packet replication. In addition to the reliability, the simulation evaluations have found end-to-end packet latency reductions of up to 40% with a packet replication factor of 1, demonstrating the latency reduction potential of path diversity.

1) *Summary and Lessons Learnt:* Although packet replication is a promising method to achieve deterministic network characteristics, especially in regards to end-to-end packet latency, several pitfalls may severely affect the network operations, requiring careful network design. Pitfalls include increased bandwidth requirements, increased energy consumption, and potentially latency increases. More specifically, bandwidth shortages may arise when replicated packet traffic competes with non-replicated traffic, potentially increasing congestion and delays. Also, as the number of flows with

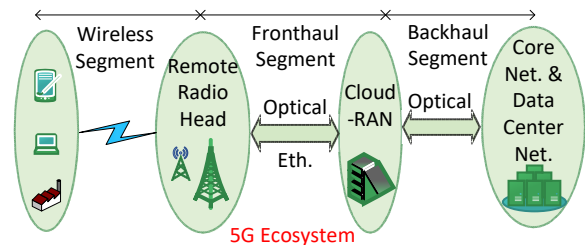

Fig. 24. The main network segments that constitute the 5G ecosystem are the wireless, fronthaul, backhaul, core, and data center segments. In addition to various research efforts over wireless segments, a variety of research efforts have been conducted in the fronthaul, backhaul, core, and data center networks. In this article we focus on the ULL techniques in these network segments

packet replication increases in the network, the flow management process becomes extremely difficult in the event of failures that require the reallocation of resources. Therefore, addressing the packet replication challenges is a critical aspect of designing reliability mechanisms. SDN based flow management mechanism can potentially optimize the replication factor while minimizing the bandwidth utilization, consumed energy, and end-to-end packet latency.

C. Discussion on DetNet Research Efforts

Overall, there has been relatively little DetNet research to date, leaving a wide scope for future research on architectural and protocol improvements. Key future research challenges include the control plane management, virtualization, and the inter-operation with external networks. DetNet depends on TSN to support deterministic L2 layer support, and hence requires strict scheduling techniques for resource sharing over L2 layers. Moreover, flow synchronization and flow control (e.g., for traffic shaping) are generally L2 features and hence DetNet does not address these aspects. On the other hand, flow management is a fundamental aspect of DetNet to oversee the management of end-to-end flow connections. SDN inherently provides a centralized management platform to manage the end-to-end connections through continuous monitoring and network reconfigurations to preserve the deterministic network service characteristics. SDN can also play an important role in integrating DetNet with external networks, as well as in operating in both small scale and large scale wide area networks. There has also been a lack of use case definitions in emerging markets, such as automatic driving and industrial control networks.

VII. 5G ULTRA-LOW LATENCY (ULL)

5th Generation (5G) cellular technology is a paradigm shift in the network connectivity as 5G is expected to provide a comprehensive overhaul to the network infrastructure by establishing an end-to-end ultra-reliable and ultra-low latency connection [3], [32]. 5G is also expected to improve the network efficiency in terms of network utilization, control plane overhead, and energy savings.

As illustrated in Fig. 24, the overall 5G ecosystem can be classified in terms of wireless access, fronthaul, backhaul,

core, and data center network segments. The wireless access is responsible for the wireless connectivity between the devices and the radio nodes. The fronthaul connects the radio nodes to the radio baseband processing units, while the backhaul connects the radio baseband processing units to core networks. The core network interconnects with the data center networks to provide end-to-end services to devices. A large number of 5G research efforts have been conducted in the wireless access domain; additionally, many articles have presented overviews of the 5G advancements [151]–[161].

The recent survey on low latency characteristics in 5G by Parvez et al. [25] focuses on waveform designs, wireless protocol optimizations, microwave backhaul architectures, SDN architectures for backhaul and core networks, and content caching mechanism for 5G. In contrast, our focus is on the low latency services that enable the fronthaul and backhaul mechanism in regards to the transport mechanisms, such as Ethernet. To the best of our knowledge, there is no prior survey that comprehensively covers the ULL aspects across the 5G network segments from the fronthaul to the core networks focusing on the transport mechanisms of the user data and the control plane signalling. We fill this gap by providing a comprehensive survey of ULL techniques across the wireless access, fronthaul, backhaul, core networks in this section (Sec. VII). Sec. VIII covers the ULL mechanisms related to the data center segment.

5G ULL mechanisms are motivated by applications that require ultra low end-to-end latency. As discussed by Lema et al. [162], the business use cases for low latency 5G networks include health-care and medical, driving and transport, entertainment, and industry automation. Remote health-care and medical interventions, including robotic tele-surgery, require reliable communication with ultra-low latency. Assisted and automatic driving require high data rates for sensor data processing as well as low latency to ensure quick responses to changing road conditions. Immersive and integrated media applications, such as Augmented Reality (AR) and Virtual Reality (VR) for gaming and entertainment require high data rates for video transmissions and extremely low latency to avoid the jitter in the video and audio. With these demanding business needs and application requirements, 5G is expected to continuously evolve to support ultra and extremely-low latency end-to-end connectivity.

A. 5G ULL Standardization Efforts

In this section, we identify the key components in 5G standards for supporting ULL mechanisms. Various standardization organizations contribute to the development of 5G standards, including the IEEE and IETF, as well as the Third Generation Partnership Project (3GPP), and the European Telecommunications Standards Institute (ETSI). We first discuss the standards related to the 5G fronthaul interface, and subsequently we present the 5G architecture components which include the backhaul. The fundamental latency limits of 5G standards are summarized in Table III. The 4.9G corresponds to the optimization efforts for LTE towards 5G, where a drastic more than 10 fold reduction in the latency is

TABLE III
LATENCY COMPARISON AT MULTIPLE COMPONENTS OF NETWORK CONNECTIVITY OVER 3G (HIGH SPEED PACKET ACCESS (HSPA)), 4G (LTE), 4.9G (PRE 5G), AND 5G [163].

Delay Comp. (ms)	3G	4G	4.9G	5G
DL Trans.	2	1	0.14	0.125
UL Trans.	2	1	0.14	0.125
Frame alig.	2	1	0.14	0.125
Scheduling	1.3	0-18	Pre-sch.	Cont. based and pre-sch.
UE proc.	8	4	0.5	0.250
eNB proc.	3	2	0.5	0.250
Trans.+Core	2	1	0.1	0.1
Total Delay (ms)	20	10-28	1.5	1

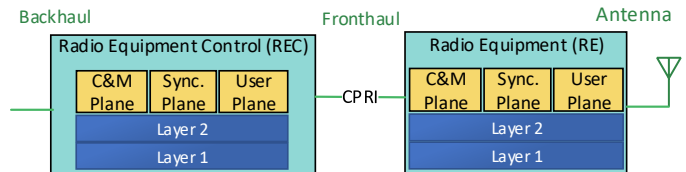

Fig. 25. Common Public Radio Interface (CPRI) system overview [164]: The Radio Equipment Control (REC) connects to the Radio Equipment (RE) via the CPRI interface. The REC is part of the Base Band Unit (BBU) and the RE is part of the Remote Radio Head (RRH) in the Cloud-RAN architecture.

achieved. The current standardization efforts have targeted the total delay for 5G to be 1 ms or lower.

1) Common Public Radio Interface (CPRI and eCPRI):

a) *CPRI*: The Common Public Radio Interface (CPRI) [165] is a digital interface for transporting information between Radio Equipment (RE) and Radio Equipment Control (REC). The RE resides at the Remote Radio Head (RRH) and is responsible for the transmission of radio signals while the baseband signal processing is conducted at the BaseBand Unit (BBU) which implements the REC. In particular, CPRI provides the specifications for packing and transporting baseband time domain In-phase/Quadrature (I/Q) samples. Figure 25 illustrates the connectivity of BBU and REC with the RRH and RE using the CPRI. CPRI mandates the physical layer (L1) to be optical Ethernet transmissions over fiber, while the MAC layer can include control and management, synchronization, and user data. CPRI has been widely adapted for LTE and 4G deployments due to the protocol simplicity and readily available dark fiber owned by cellular operators [166].

5G is expected to support high bandwidth connections up to several Gbps, resulting in very high effective I/Q CPRI data rates. For instance, a massive MIMO connectivity with 64 antennas for both transmission and reception would result in more than 100 Gbps requirement [167]. Additionally, the CPRI Service Level Agreements (SLAs) require delays below 75 μ s. Therefore, CPRI poses serious scalability issues as the required data rate increases drastically with the number of antennas for massive MIMO especially in 5G Networks [167]. Dense Wavelength Division Multiplexing (DWDM) and Optical Transport Networks (OTNs) can support the stringent CPRI SLA requirements. However, dense deployments of 5G radio nodes due to the short mmWave range requires fiber connectivity to large numbers of radio nodes. Therefore, eCPRI, an

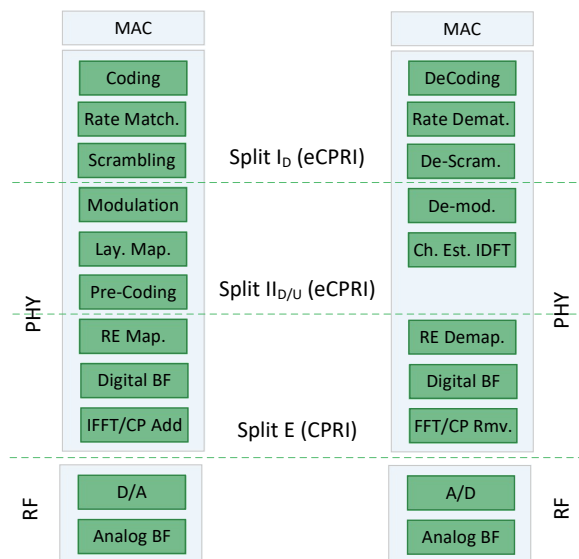

Fig. 26. Split options defined by eCPRI: split E corresponds to the CPRI data, split II_D corresponds to downlink data after pre-coding, split I_U corresponds to uplink data after RE-demap, and split I_D corresponds to data after scrambling operation in the downlink.

TABLE IV
CPRI SPLIT E AS WELL AS eCPRI SPLITS I_D , II_D (DOWNLINK), AND I_U (UPLINK) ONE-WAY PACKET DELAY AND PACKET LOSS REQUIREMENTS [169].

CoS name	Example use	One-way max. packet delay	One-way pkt. loss ratio
High	User Plane	100 μ s	10^{-7}
Medium	User Plane (slow), C&M Plane (fast)	1 ms	10^{-7}
Low	C&M Plane	100 ms	10^{-6}

enhanced version of CPRI, has been proposed to address the scalability issues of CPRI [168]. The 5G fronthaul enabled by eCPRI will not only reduce the effective bandwidth, but also relax latency requirements compared to CPRI. Generally, the scheduling delay is a major delay component. 5G implements pre-scheduling and contention based data transmission where data is piggybacked onto RACH and sent directly without the connection establishment to reduce the scheduling delay.

b) *CPRI*: eCPRI reduces the effective data rate carried over the L1 connection between RE and REC. eCPRI also removes the mandatory L1 requirements, thus allowing operators to implement cheap Ethernet links. More specifically, the data rate reduction is achieved by various functional split options as show in Fig. 26. eCPRI primarily defines two split options in the downlink. The I_D splits performs PHY layer bit scrambling at the BBU, while RF transmissions are modulated at the RRH. Similarly, the II_D splits conducts pre-coding, Resource Element (RE) mapping, digital Bandpass Filter (BF), and IFFT/FFT and Cyclic Prefix (CP) at the BBU. In contrast to the downlink, eCPRI defines only one split option in the uplink I_U , whereby the PHY layer functions, including the channel estimation and beyond, are conducted at the BBU, while RE demapping to RF transmissions are processed at the RRH. In contrast to eCPRI, CPRI only carries the output from the IFFT/FFT and Cyclic Prefix (CP) at the BBU to

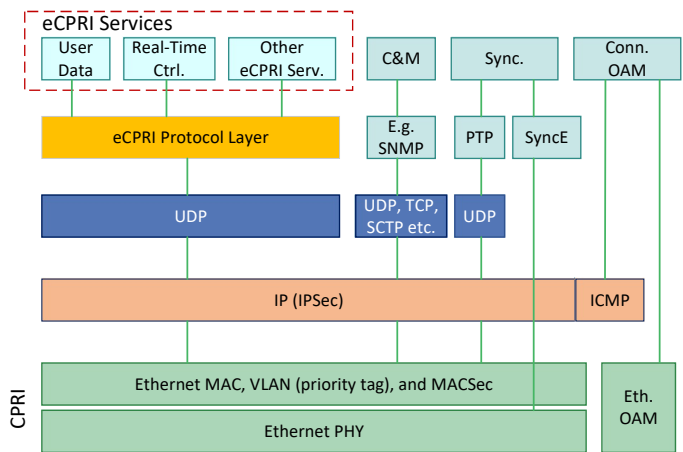

Fig. 27. The eCPRI protocol stack consists of the eCPRI protocol layer, which transports the data from various split options over generic UDP and IP protocol layers. The lower layers, PHY and MAC, are equivalent to the CPRI protocol. The eCPRI services as well as the eCPRI control and management data along with synchronization are supported by the eCPRI protocol stack.

the RF Digital to Analog (D/A) converter at the RRH. The delay requirements for the various Classes of Service (CoS) for the I_D and II_D splits (eCPRI) and the E split (CPRI) are summarized in Table IV. The high CoS corresponding to split E (CPRI) requires the one way maximum packet delay to be on the order of 100 μ s. The split E transports the I/Q data and in-band Control and Management (C&M) information. The medium CoS, which supports both the user and C&M plane data, requires 1 ms delay. The low CoS for the uplink eCPRI I_U split requires 100 ms delay.

The eCPRI services include:

- i) User plane I/Q data transport between BBU and RRH, user plane control and management (C&M), and support services, such as remote reset.
- ii) Time synchronization between BBU and RRH.
- iii) Operation and management (OAM), including eCPRI connection setup, maintenance and tear down.

eCPRI supports various message formats to transport I/Q data according to the adopted split option. The protocol stack description of eCPRI services over IP and Ethernet is illustrated in Fig. 27. The eCPRI specific protocol layer transports the time domain I/Q data for split E, or frequency domain I/Q data for splits I_D and I_U . eCPRI messages are transmitted as UDP/IP packets whereby the eCPRI header and data constitute the UDP packet payload. The UDP packet headers contain both the source and destination IP addresses of the eCPRI nodes. Various message types control the overall operation of eCPRI over Ethernet links, including one-way delay measurement, remote reset, and event indication.

Unlike CPRI, which requires point-to-point and point-to-multipoint operation in a master-to-slave configuration, eCPRI is agnostic to the network topology which may encompass local area networks, as well as public routers and switches. The logical topologies that are possible with eCPRI include:

- Point-to-point, i.e., one BBU to one RRH which is similar to CPRI.

- Point-to-multi-point, i.e., one BBU to multiple RRHs (supported in CPRI as well)
- Multi-point-to-multi-point, i.e., multiple BBUs to multiple RRHs (mesh configuration), unique to eCPRI.

In a generalized Ethernet network carrying multiple traffic types (including best effort traffic), the user plane I/Q data and the real time O&M data require high priority transmissions. TSN mechanisms, see Sec. III, can enable Ethernet networks to meet the eCPRI delay requirements. Traffic carrying eCPRI management messages and user plane data can be regarded as the Control Data Traffic (CDT) that is transmitted with high priority scheduling over the TSN network. Traffic requirements for user plane data vary for the different split options, which can be assigned different TSN priority levels. For instance, the C&M data is typically not as delay sensitive as user plane data; hence, a lower priority can be assigned to C&M traffic. However for critical C&M data, such as remote reset while troubleshooting a Remote Equipment (RE) problem may require higher priority levels than user data. Therefore, two priority levels can be assigned to C&M traffic, i.e., a part with priority higher than user data and other part with priority lower than user data. These priority levels can be readily supported by TSN networks, which accommodate eight independent priority queues.

c) *Summary and Lessons Learned:* 5G technology supports diverse applications with a wide range of data rates and latency requirements, which directly translate to requirement for a flexible and scalable fronthaul. CPRI and eCPRI provide standardized protocols for inter-operating with existing cellular infrastructures. CPRI may not be suitable for supporting massive broadband services due to the very high required I/Q data rates. Also, the CPRI latency requirements need to be carefully considered and may require the judicious use of the scheduled traffic concept [106]. eCPRI overcomes the data rate issue through functional splits but increases the complexity of remote radio nodes. Another shortcoming of eCPRI is that the system considers asymmetrical OFDM in-downlink and uplink, i.e., SC-OFDM in the uplink. Symmetrical OFDM systems are being investigated for increased spectral uplink efficiency [167]. However, there is no specific split defined for symmetrical OFDM systems in eCPRI. Remote spectrum analysis for troubleshooting RF issues is possible in CPRI; whereas, eCPRI does not provide such remote RF evaluation capabilities, although splits I_U and I_D allow for remote RF management. Hence, transmission of sampled time domain I/Q samples from RRH back to the BBU must be developed for advance troubleshooting mechanisms.

2) *IEEE 802.1CM: Time-Sensitive Networking for Fronthaul:* The IEEE 802.1CM standard [170] is a CPRI-IEEE 802.1 collaboration to provide bridged Ethernet connectivity for fronthaul networks. An 802.1CM bridge must support a data rate of 1 Gbps or higher on each port. The IEEE 802.1CM requirements are derived from CPRI and eCPRI so as to support various splits, such as splits at the FFT, demapping, and scrambling radio functions. IEEE 802.1CM defines mechanisms for end stations, bridges, and LANs to establish Ethernet networks that can support the time sensitive transmissions of fronthaul streams. In the current cellular

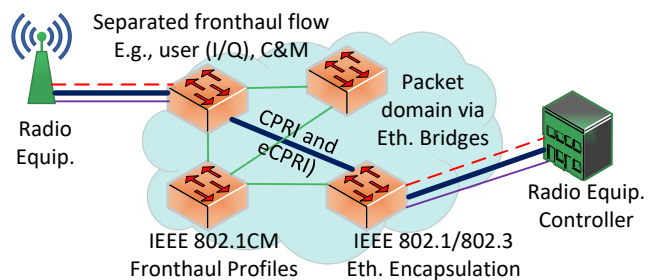

Fig. 28. IEEE 802.1 CM defines the support for Ethernet-based fronthaul in a bridged network. Flows are separated into different classes and a specific fronthaul profile is applied to each class to transport the flows over the Ethernet bridges based on the flow requirements.

network deployments, the separation between RRH and BBU requires connectivity with stringent latency and capacity requirements. These fronthaul connection requirements could not be readily provided by today's bridged Ethernet networks.

IEEE 802.1CM provides specific mechanisms, such as scheduling, preemption and synchronization mechanisms, to satisfy the fronthaul requirements. Mobile operators can utilize large segments of existing bridged networks to support 5G fronthaul networks, reducing capital expenditures. Moreover, centralized management mechanisms can be employed for automatic network reconfigurations, reducing the operational expenditures compared to manual network configuration. IEEE 802.1CM distinguishes Class 1 traffic for CPRI and Class 2 traffic for eCPRI. In terms of network synchronization, two mechanisms are specified in the IEEE 802.1 CM standard: i) packet timing using protocols, such as the Precision Time Protocol (PTP) for point-to-point synchronization distribution from a remote common master, and ii) co-located common master for both BBU and RRH.

a) *Latency Components of a Bridge:* A bridge supporting fronthaul network functionalities needs to tightly control the latency and synchronize its functions. The latency for a single hop in a bridge network is the time duration from the arrival of the last bit of a given frame at a given port in a bridge to the arrival of the last bit of the same frame at a particular port at the next hop bridge. The main delay component are:

- Store and forward delay t_{SF} due to all the elements responsible for the internal frame forwarding from ingress to egress port.
- Queueing (interference) delay $t_{Queueing}$ due to ongoing transmissions of higher priority frames.
- Self queuing delay $t_{Self_Queueing}$ due to frames of the same class that arrive across multiple ports and need to be sequentially queued.
- Periodic Constant Bit Rate (CBR) high priority data flow delay $t_{MaxGoldFrameSize+Pre+SFD+IPG}$ e.g., IQ data are referred to as gold flows in IEEE 802.1 CM. Delay of a gold frame with max. frame size with Preamble (Pre), Start Frame Delimiter (SFD), and the Inter Packet Gap (IPG).

The total worst-case self-queuing delay in a bridge can be evaluated based on the number N of ingress ports can receive interfering gold frames which need to be transmitted over egress port p , and the total number of flows $F_{i,p}$ supported

between ingress port i and egress port p . Let $G_k^{i,p}$ denote the maximum of number of frames belonging to a gold flow k traversing from ingress port i to egress port p that can be grouped into a single time window before the reception of frames at the ingress edge port of the bridge network. The resulting worst case self-queuing delay at port j can be evaluated as

$$t_{\text{Self_Queueing}}^{j,p} = t_{\text{MaxGoldFrameSize+Pre+SFD+IPG}} \times \sum_{i=1, i \neq j}^{N_P} \sum_{k=1}^{F_{i,p}} G_k^{i,p}. \quad (1)$$

Therefore, the total worst-case delay $t_{\text{MaxBridge}}$ for gold flows in a bridge can be evaluated as

$$t_{\text{MaxBridge}} = t_{\text{MaxGoldFrameSize+Pre+SFD+IPG}} + t_{\text{SF}} + t_{\text{Queueing}} + t_{\text{SelfQueueing}}. \quad (2)$$

Without preemption, the maximum queuing delay t_{Queueing} incurred by gold flows depends on the maximum size of the low priority frame along with preamble (Pre), Start Frame Delimiter (SFD), and the Inter Packet Gap (IPG) which results in $t_{\text{Queueing}} = t_{\text{MaxLowFrameSize+Pre+SFD+IPG}}$. However with preemption, a high priority frame is transmitted right after the transmission of the fragment of the preemptable frame, which includes the Cyclic Redundancy Check (CRC) and Inter Frame Gap (IFG).

b) Fronthaul Profiles: In general, the fronthaul flows in a bridged network are classified into High Priority Fronthaul (HPF), Medium Priority Fronthaul (MPF), and Low Priority Fronthaul (LPF) flows. The HPF corresponds to class 1 I/Q data and class 2 user plane data with the requirement of 100 μs end-to-end one-way latency. Similarly, the MPF corresponds to the class 2 user plane (slow) data and class 2 C&M (fast) data. The LPF could include the C&M data of class 1 and 2 traffic. IEEE 802.1 CM defines two profiles, namely profiles A and B, to service different fronthaul technologies supporting both class 1 and 2. The priority assignment for the MPF data is typically considered to a priority level which is immediately below the HPF. Whereas, the LPF data is assigned to a priority which is immediately below MPF. In contrast to the traffic classes which are designed based on the relative priorities, the profiles are designed based on the worst-case end-to-end delay within a given traffic class.

Profile A: The goal of profile A is to simplify the deployments and support only strict priority, focusing on the transport of user data (i.e., I/Q) as high priority traffic class and C&M data with lower priority traffic class. The maximum frame size for all traffic is 2000 octets.

Profile B: Profile B adopts advanced TSN features, including frame preemption, as defined in IEEE 802.3br and 802.1Qbu, as well as strict priorities to carry user data (i.e., I/Q) as high priority traffic class and C&M data as low priority preemptable traffic classes. The maximum frame size for user data is 2000 octets, while all other traffic can have variable traffic sizes.

c) Summary and Lessons Learned: IEEE 802.1CM primarily supports CPRI and eCPRI connectivity over bridged

networks. IEEE 802.1CM enables cellular operators to use the existing Ethernet infrastructure reducing the capital and operational expenditures. However, the lack of support for generalized fronthaul limits the applicability of the IEEE 802.1CM standard to a wider set of 5G applications such as crosshaul [171]. The relative performance of the low priority traffic as compared to the higher priority traffic still needs to be thoroughly investigated to understand the behavior of traffic classes when operated with high loads that approach the link capacities.

Although the delay and synchronization aspects have been specified in the standards, the security and reliability issues have not yet been considered in detail. Hence, security and reliability present a wide scope for future research and standards development. These security and reliability issues can be investigated by the fronthaul task force which is responsible for the IEEE 802.1 CM standards development.

We note that a cellular operator may choose to change priority levels as desired. Hence a pitfall to avoid is when regular traffic (i.e., non-fronthaul traffic) is assigned higher priority than fronthaul user data or C&M traffic, then the self-queuing and queuing delay would increase for the fronthaul traffic. Thus, the relative priority levels of the different traffic priority classes needs to be carefully considered in the network resource allocation.

3) Next Generation Fronthaul Interface (NGFI):

a) Overview: Although the IEEE 802.1 CM, CPRI, and eCPRI fronthaul protocols provide implementation directions for fronthaul networks, the lack of fronthaul architectural standardizations has prompted the IEEE standards group to commission the IEEE 1914 Working Group (WG) [172] to define the standards for packet-based Fronthaul Transport Networks (FTN). In particular, the IEEE 1914 WG has defined two standards: *i)* IEEE P1914.1 focusing on architectural concepts related to both data and management fronthaul traffic in an Ethernet based mobile FTN networks, and *ii)* IEEE P1914.3 focusing on the encapsulation of I/Q data for Radio Over Ethernet (RoE). In comparison to IEEE 1914.3, the latency impact on the fronthaul deployment is mainly influenced by IEEE P1914.1. Hence, we primarily focus on architectural concepts, protocol operations, traffic management, and requirements as well as the definitions for fronthaul link as defined by IEEE P1914.1. The goals of IEEE P1914.1 are to support 5G critical use cases, such as massive broadband services and to design a simplified fronthaul architecture which can utilize the existing standard Ethernet deployments of cellular operators. However, IEEE 1914.1 distances itself from defining the functional split aspects of the fronthaul, while aligning with 3GPP to support functional split suitable for 5G.

b) Two-Level Fronthaul Architecture: IEEE P1914.1 defines a two-level fronthaul architecture that separates the traditional RRU to BBU connectivity in the CRAN architecture into two levels, namely levels I and II. Level I connects the RRH via a Next Generation Fronthaul Interface-I (NGFI-I) to a new network element, the so-called Digital Unit (DU). Level II connects the DU via an NGFI-II interface to the Central Unit (CU), as shown in Fig. 29(a). Figs. 29(b) and (c) show different deployment options with integrated RRH and DU,

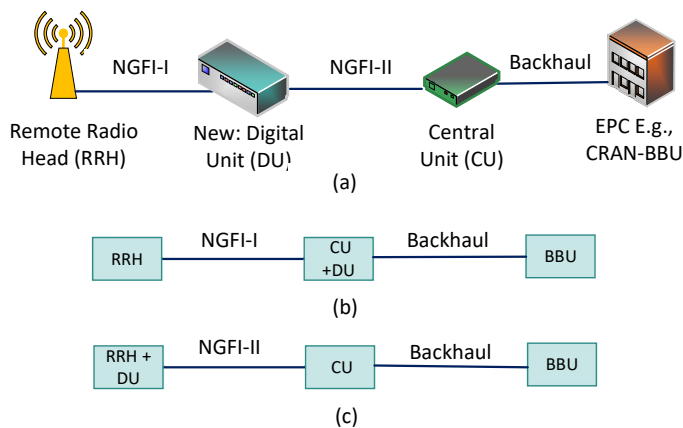

Fig. 29. Illustration of two-level architecture options for next-generation fronthaul transport network: (a) RRH is connected via NGFI-I fronthaul interface to Digital Unit (DU) and DU is connected via NGFI-II interface to Central Unit, (b) RRH is connected via NGFI-I interface to integrated CU and DU, and (c) DU is integrated with RRH and connected via NGFI-II to CU.

TABLE V
NGFI TRANSPORT CLASSES OF SERVICE

Class	Sub Class	Max. Lat.	Pri.	App.
C&M	Sync.	TBD	TBD	
	Low Lat. RAN ctrl. plane	100 μ s	2	
Data Plane	Subclass 0	50 μ s	0	ULL data
	Subclass 1	100 μ s	1	Low split.
	Subclass 2	1 ms	2	Med. split
	Subclass 3	3 ms	3	High split
	Subclass 4	10 ms	4	Legacy Backhaul
Trans. Net. C&M	Trans. Net. ctrl. plane	1 ms	2	

and with integrated CU and BBU, respectively. The purpose of the two-level architecture is to distribute (split) the radio node (i.e., eNB/base station) protocol functions between CU and DU such that latencies are relaxed, giving more deployment flexibilities. In general, NGFI-I is targeted to interface with the lower layers of the function split which have stringent delay and data rate requirements. In contrast, NGFI-II is targeted to interface with higher layers of the function split relative to NGFI-I, relaxing the requirements for the fronthaul link.

The NGFI is designed to mainly address:

- i) Scalability: To enable C-RANs and Virtual-RANs that are functional split and traffic independent.
- ii) Resource Utilization: To achieve statistical multiplexing by supporting variable MIMO and Coordinated Multi-point (CoMP) for 5G.
- iii) Flexibility: To operate in a radio technology agnostic manner while supporting SDN controlled dynamic reconfiguration.
- iv) Cost Effective: To utilize existing cellular network infrastructure.

Additionally, NGFI supports connectivity to Heterogeneous Networks (HetNets) by decoupling the transport requirements from the radio technologies. Thus, multiple traffic classes, as summarized in Table V, can be transported by the NGFI

network, mainly to support latencies according to the application demands. The C&M class supports low-latency control plane data for radio node signalling. Data plane latencies vary according to the different subclasses 0–4 to support multiple technologies and deployment versions with multiple split options. Subclass 0 requires the highest priority with 50 μ s of maximum allowed latency, while subclass 4 has the lowest priority and a 10 ms maximum delay bound. For instance, subclass 4 can be used for the legacy backhaul over the NGFI interface. The traffic of each subclass is independently transported between the end points without any mutual interference while achieving statistical multiplexing gain among the subclasses.

c) *Summary and Lessons Learned:* The NGFI primarily addresses the scalability and cost issues with the current fronthaul solutions, such as CPRI where connections between DU and CU can be directly connected by an Ethernet link supporting IEEE P1914.1 specifications. For the existing deployments with CPRI solutions, the NGFI L2 transport service with subclass 0 can readily accommodate the requirements without any changes to the infrastructure deployments. Thus, NGFI is expected to play a significant role in the unification of heterogeneous radio technologies at the transport level and support converged fronthaul and backhaul networks for both convergence and coexistence of 4G and 5G technologies. An important aspect to investigate in future research is the trade offs between link utilization and multiplexing gain for the standard Ethernet networks while adopting these new fronthaul support architectures and protocols.

4) Backhaul Networks:

a) *Overview:* The backhaul networks consisting of core network elements play a critical role in setting up the end-to-end flows. Core networks control the user data scheduling in both uplink and downlink. The control signalling of the radio technology, e.g., LTE, can contribute to flow latency when user devices transition among various states, e.g., idle to active (connected) and vice versa. For scenarios with intermittent data activity, devices typically implement a state transitioning mechanism from active to idle to conserve computing and wireless resources. For instance, if the inter packet delay is more than 40 ms, the device can pro-actively change the radio control state to idle. Thus, within a single ULL flow session, there can be multiple user device state transitions between idle and active. The core network manages the control plane signalling of the radio technology whereby advanced methods can be implemented to reduce the state transition overhead during flow setup, thereby reducing the latency. For ULL flows, whether the traffic is intermittent or has a constant bit rate, the end-to-end latency should be minimized for both flow setup and steady state traffic flow.

An efficient backhaul network design can reduce control plane signalling for both initial ULL flow setup and steady state traffic. We give brief overviews of the two standardization efforts that efficiently implement the 5G core network functions for setting up and supporting ULL flows, namely Control and User Plane Separation (CUPS) of EPC and Next Generation (NG) Core.

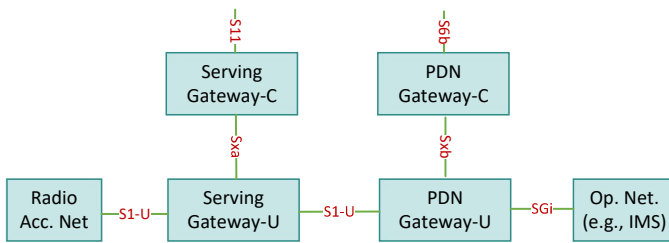

Fig. 30. Illustration of Control and User Plane Separation (CUPS) for the EPC as proposed by the 3GPP [173]. The Serving-GW (S-GW) functions and the PDN-Gateway (P-GW) functions in the EPC are split between S-GW-C (i.e., control), S-GW-U, and P-GW-U (i.e., user) to increase the flexibility of existing EPC networks.

b) Control and User Plane Separation (CUPS) of EPC:

The SDN paradigm of separating the control and data plane functions while centralizing the overall control plane has provided substantial advantages in traditional networks, such as data center networks. The 3GPP has proposed Control and User Plane Separation (CUPS) [173] for the Evolved Packet Core (EPC) backhaul of the LTE radio technology to adapt SDN principles in the cellular backhaul core networks to achieve similar benefits. In the current network deployments, cellular operators are facing increased capital and operational expenditures while scaling the infrastructures to meet the capacity demand from the users. This infrastructure scaling problem is exacerbated by the integrated control and user plane functions in the existing backhaul networks. Thus, the main advantages of CUPS are *i)* flexible deployments in both distributed and centralized control plane, and *ii)* independent scaling of control and user plane functions.

CUPS plays an important role in reducing the overall end-to-end latency through the cellular operator networks by choosing the user plane nodes that are close to the RAN node. In particular, the data is transported without having to interact with the control plane nodes for the path setup, which is especially beneficial for user mobility scenarios. That is, the flow paths of user plane nodes are dynamically adapted according to the requirements and mobility, without having to negotiate with control plane entities, such as SGW-C and PGW-C. This capability will greatly increase the backhaul flexibility for the existing LTE radio technology deployments. The new interfaces Sxa, Sxb, and Sxc have been introduced to communicate between the control and user planes of the Serving-GW (S-GW). The CUPS architecture has been presented in Fig. 30 and the highlights of CPUS in comparison to the existing EPC are:

- i) Removal of GPRS Tunneling Protocol (GTP) and session management between control plane entities.
- ii) A cross connection interface between control and user plane, where any control function can interact with any user function.
- iii) A UE is served by a single control plane, but the data flow path may go through multiple data plane functions.
- iv) A control plane function is responsible for creation, managing, and terminating a flow over the user plane functions. All the 3GPP control functions, such as PCC,

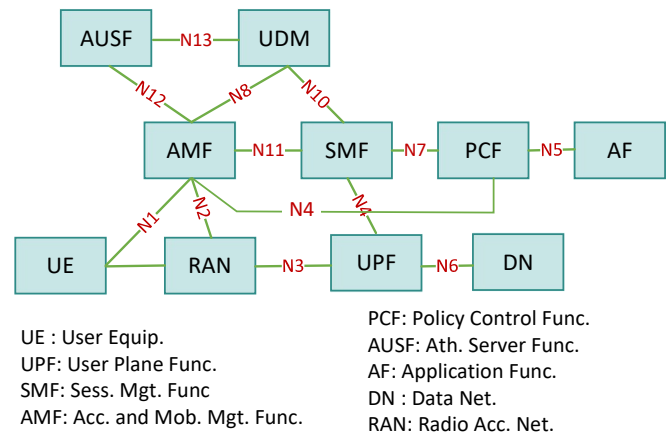

Fig. 31. Illustration of 3GPP Next Generation (NG) Core: Point-to-point reference architecture based on service functions to support 5G radio nodes.

charging, and admission control are supported within control plane function, while the user plane is completely agnostic to the 3GPP control functions.

- v) A legacy EPC consisting of S-GW and PDN-GW can be replaced with new user plane and control plane split nodes without any impact on existing implementations.

c) Summary and Lessons Learned: CUPS provide a mechanism to adapt advanced resource management functions, such as SDN, to existing networks while improving the flexibility. The reduction of data plane and control plane overhead, particularly the removal of GTP tunneling, allows user data to be transported without the encapsulation and GTP sessions. Moreover, the user device state transitions trigger control plane activities in the core networks. Therefore, the separation of control and data plane not only increases the flexibility but also reduces the radio control signalling to support ULL flows. Thus, cellular operators can incrementally upgrade towards 5G deployments. For distributed deployments, future research needs to thoroughly examine the placement and implementation of control and user plane entities without impacting the overall EPC system behavior.

5) Next Generation (NG) Core:

a) Overview of NG Core Architecture: The 3GPP Next Generation (NG) core [174] is equivalent to the LTE Evolved Packet Core (EPC). However, the NG core network has been redesigned to separate and isolate the network nodes based on service functions, i.e., function related to the radio technology service, such as user authentication and session management. While EPC core provides the network functionality for the LTE backhaul, the NG core specifically provides the backhaul for the standalone 5G New Radio (NR) technology [175]. A non-standalone 5G would operate in coexistence with EPC and LTE support. The existing EPC core collectively implements multiple service functions defined for LTE radio technologies within the backhaul network gateways, such as S-GW and P-GW in a combined fashion. In contrast, the NG core separates the service functions at the network nodes level. The service function concept is akin to Network Function Virtualization (NFV) in that multiple virtualized network functions are needed to implement a single service function of a radio

technology.

b) NG Core Elements: The point-to-point NG core architecture is based on service functions supporting the 5G radio nodes, as shown in Fig. 31. The fundamental motivation of the NG core is to support advanced network implementations and network management schemes, such as network slicing, NFV, network service function chaining, and SDN to address the scalability and flexibility of the core network. Each NG core element is connected to other elements through Nx interfaces. Critical NG core elements include:

- i) The Access and Mobility Function (AMF) implements the access control and mobility aspects of the user context.
- ii) The Session Management Function (SMF) is responsible for the data path setup and tracking and terminating based on the policy function.
- iii) The User Plane Function (UPF) defines the data path characteristics based on the users requirements and policy.
- iv) The Policy Control Function (PCF) controls the user policy, such as roaming and network resource allocations for network management, including network slicing.
- v) The Unified Data Management (UDM) manages the subscriber information which is used for admission control and for defining the data path policies.
- vi) The Network Repository Function (NRF) maintains the registry of service functions distributed throughout the network.

c) Summary and Lessons Learnt: The NG core decouples the network service functions from gateway functions allowing core network to implement the network nodes based on service functions enhancing the deployment flexibility. As a result, operators have more freedom in transitioning from an existing core network to the NG core by separating the core network elements based on the service functions. However, future research needs to thoroughly examine the overhead of the control plane management, e.g., virtualization [176]. For instance, the overhead directly influences power consumption, and network efficiency for the ULL flow setup in the core network data path, which must be carefully evaluated. Therefore, performance, resource utilization, and overhead must be considered while designing the optimal infrastructure deployment.

6) Discussion on 5G ULL Standardization Efforts: In this section we have provided a brief overview of key components in the 5G standardization efforts that contribute to ULL connectivity. Several wireless connectivity and signalling optimizations have reduced the latency overhead in the data and control planes of the wireless air interface. An example is the contention based data transmission without a grant, i.e., simultaneous Random Access CHannel (RACH) preamble + data transmission. Also, the new Radio Resource Control (RRC) inactive state reduces the signalling for the RRC inactive to active state transition (compared to the conventional LTE RRC idle to RRC active transition). In addition to the wireless air interface, 5G network latency components are incurred in fronthaul, backhaul, and core networks. A wide variety of options, e.g., functional splits of CPRI and

NGFI for the fronthaul, exist for meeting the requirements of 5G components. Therefore, the design of an end-to-end 5G supported system requires a comprehensive latency analysis across all segments to select the right candidate set of transport mechanisms, protocols, and architectural solutions.

Overall, the adaptability of each solution for 5G deployment could impact the end-to-end ULL flow latency. Flexibility could improve the scalability and network utilization, but the control plane separation requires careful consideration of control plane overhead and latency. Similarly, deployments of new architectures, such as NG core, could result in efficient backhaul management to support ULL mechanism with minimal overhead, but may require high expenditures for cellular operators. Nevertheless, as deployment options vary widely based on the implementation, relative performance evaluation based on distances between different nodes, interfaces, protocol overhead, transport mechanisms, and architectural consideration need to be conducted in future research as ground work towards optimal 5G system design.

B. 5G ULL Research Efforts

1) 5G Wireless Access ULL Research Efforts: In this section we survey ULL techniques in the 5G wireless access segment. Efforts to reduce the latency in the wireless access segment have been mainly focused on two aspects: *i)* shortening of the Transmission Time Interval (TTI), and *ii)* reduced processing time for each TTI [187]. The TTI is the fundamental time unit for the protocol operations, e.g., transmissions, in a given wireless technology, e.g., LTE. A shorter TTI contributes to an overall reduced Round-Trip Time (RTT) due to shorter cycles. For example, in LTE, the number of OFDM symbols in one TTI can be reduced from 7 to 2 or 3 OFDM symbol to reduce the latency [188]. In contrast to LTE which uses only Orthogonal Frequency Division Multiplexing (OFDM) based waveforms, the New Radio (NR) access technology [189] for 5G provides a platform to design and implement more flexible waveforms based on both OFDM and non-OFDM over wide range spectrum resources including microwave and mmWave [190].

In terms of reducing the TTI processing time, if a given TTI is divided into sub-blocks, and each block is independently processed in a pipelined fashion, the overall processing time can be reduced [187]. Without pipelined processing, the radio node has to wait for the entire TTI frame to arrive before starting to process the symbol, incurring the delay. Figure 33 demonstrates how pipelined processing reduces the overall latency by the dividing a single TTI frame into multiple sub blocks.

As an alternative to reducing the number of OFDM symbols in a TTI for reducing the TTI duration, the OFDM sub carrier spacing in the frequency domain can be increased, thus inherently reducing the TTI duration in the time domain (i.e., reducing the OFDM symbol duration). However, such techniques require increased guard bands in both the frequency and time domains to protect from inter-carrier and inter-symbol interferences as well as increased hardware complexity in terms of tight synchronization and sensitive receiver designs.

5G ULL Research Efforts, Sec. VII-B

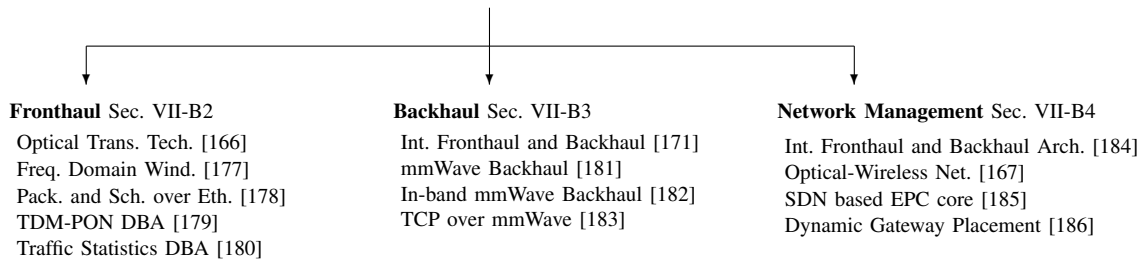

Fig. 32. Classification of 5G Research Efforts.

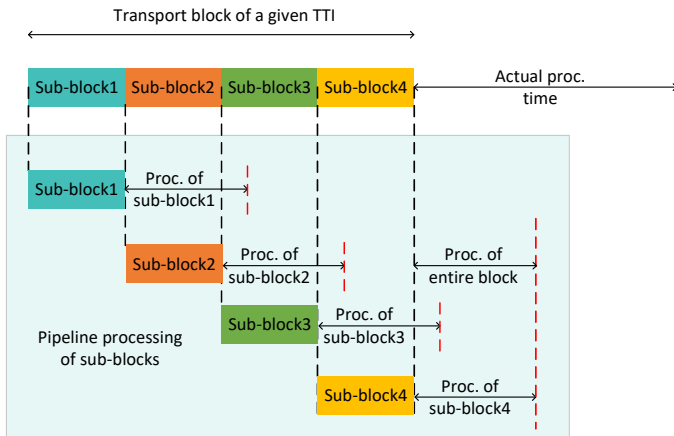

Fig. 33. A given frame can be divided into multiple sub-blocks. Each sub-block is independently processed without having to wait for the entire frame to arrive to start the processing, reducing the overall latency [187].

The next generation Node B radio node in the context of 5G is often referred to as gNB; this gNB is equivalent to the eNB in 4G LTE. For simplicity, we follow the common eNB terminology to refer to the radio node in both legacy and 5G technology. The wireless link latency in 5G networks can typically be attributed to two sources: *i*) user plane latency when the User Equipment (UE) is in CONNECTED state (i.e., active radio link is established between UE and radio node (eNB/gNB)), and *ii*) control plane latency when device is in idle state (i.e., no active radio link connectivity exists). For the user plane latency, especially in the uplink, the delay is constituted by scheduling, and UE to eNB transport delay, inclusive of the processing delay of packets. For the wireless control plane, the delay is constituted by the state change from IDLE to CONNECTED through a signaling process such as PAGING and Random Access CHannel (RACH). With increasing numbers of devices connecting to 5G network, robust scheduling mechanisms are essential to preserve the fairness among all the devices in terms of latency and data rate. Intermittent data generation, e.g., in IoT, increases the control plane signaling due to the IDLE to CONNECTED transitions [191]. Furthermore, in small cells environment, the device mobility, e.g., for automotive and industrial robot applications, can result in data and control plane delay. The data plane delay in mobility scenarios is associated with the wireless link discontinuity during the handover process.

Whereas, the control plane delay in the mobility scenarios is associated with the signaling over the core network due to device transitions between eNBs.

Robotic systems in industrial networks require ULL for control system loops. As compared to unlicensed wireless access (e.g., WiFi), the licensed LTE and 5G technologies not only provide ultra reliable and low latency connectivity for a closed ecosystem of industrial networks but also support seamless mobility for robotic systems [192]. The scheduling of data from the devices is a MAC layer procedure which incurs significant delays in 5G wireless networks. To address the scheduling delay, pro-active granting, similar to Semi-Persistent Scheduling (SPS), i.e., periodic grants to device for transmission, can be employed. However, pro-active granting could reduce the overall link utilization due to over-provisioning of scheduling resources. In LTE with 1 ms TTI, the Round Trip Time (RTT) for a Scheduling Request (SR) and GRANT is at least 4 ms, resulting in data transmission delays of 8 ms or more. Proactive granting can reduce the packet delay to less than 4 ms by eliminating the SR and GRANT procedures.

2) *Fronthaul*: The fronthaul segment connects the radio nodes, i.e., radio transmission nodes, and radio processing nodes, i.e., radio signal processing [193]. Typically, radio nodes are referred to as Remote Radio Units (RRUs) and radio processing nodes are referred to as Base Band Units (BBUs). Cloud-RAN (CRAN) technology [194] centralizes and virtualizes the BBU functions such that a given BBU can connect to and serve several RRHs. Initial CRAN designs entirely virtualized the BBU functions and transported only time domain In-Phase/Quadrature (I/Q) samples to RRHs. However, the time domain I/Q transport technology was limited by strict delay and bandwidth requirements that hampered the scalability of deployments. However, recent CRAN designs feature flexible BBU function separation between CRAN and RRU to meet scalability and latency demands [195], [196]. While there exists extensive discussions on fronthaul challenges and future designs [197]–[199], we focus on the key aspects of fronthaul techniques supporting ULL connectivity.

a) *Optical Transport Techniques*: The Common Public Radio Interface (CPRI) [165] imposes an overall fronthaul link delay limit of 5 ms, excluding the propagation delay [165]. Typically, the distance between BBU and RRU is 20 km with a delay tolerance of 100 μ s and a frequency accuracy within 2 ppm (parts per billion). In addition to the CPRI

requirements, the deployment consideration should also consider the availability of fiber, cost efficiency, CPRI propagation delay, as well as administration and management, since fiber providers are different from mobile network providers. The main topology consideration for deployments are the point-to-point, daisy chain, multi-path ring and mesh topologies. Point-to-point links provide dedicated fiber resources for the fronthaul connectivity, but can be expensive. The daisy chain topology allows the fiber resources to be shared among multiple RRUs; however, a link failure can impact all the connected RRUs. Multipath ring and mesh topologies provide generally a better balance between fiber availability, cost, and resilience to link failures. Fronthaul data can be transported through several optical transport techniques [166]:

Optical Transport Network (OTN): The OTN uses a TDM approach over a single wavelength which can be extended to multiple wavelengths through dense wavelength division multiplexing (DWDM). OTN has relatively high power consumption, as OTN equipment requires power for the optical transmissions at both receiver and transmitter.

Passive Optical Network (PON): PONs may provide a cost-effective option for fiber deployments, if PONs are already deployed for fiber to the home connections. Recent PON developments [200]–[203] support both high bit rates and low latencies to meet the fronthaul requirements. PON technology is also power efficient as compared to the OTN.

Point-to-Point with CWDM: Point-to-point links with a wavelength multiplexer for Coarse Wavelength Division Multiplexing (CWDM) are generally cheaper than an OTN with DWDM. Motivated by diverse optical transport options, Chanclou et al. [166] have proposed a WDM optical network solution to meet the data rates and latency requirements of the CRAN fronthaul. Automatic wavelength assignment is enabled by passively monitoring the RRUs through a self-seeded approach [204] that considers the bit rates, latencies, jitter and synchronization, as well as fiber availability of the CPRI links.

b) Frequency Domain Windowing: The general 5G end-to-end latency guideline is 1 ms, while the total fronthaul link (propagation) delay budget is 200 μs [205]. Consider a 20 km fronthaul link, then the processing delay (for CPRI signal and protocol processing) would need to be significantly lower the link (propagation) delay, i.e., on the order of few μs . The general consideration for the processing delay in the fronthaul is 5 μs . In an effort to further reduce the processing delay of 5 μs , Liu et al. [177] have designed an optical transport system supporting the CPRI-equivalent rate of 59 Gbps. 48 LTE RF signals of 20 MHz each were transmitted through a single WDM channel with an effective RF bandwidth of 1.5 GHz. The processing delay was reduced through a Frequency Domain Windowing (FDW) technique that reduces the overall FFT/IFFT size in the process of channel aggregation and de-aggregation. FDW is applied to each N -point IFFT corresponding to every aggregated channel. The FDW technique attenuates the high-frequency components such that the inter-channel crosstalk is reduced. As a result, the effective FFT/IFFT size can be reduced, thereby reducing the overall processing latency. The experimental results for the

fronthaul distance of 5 km have shown an overall fronthaul delay reduction from 5 μs to 2 μs .

c) Packetization and Scheduling over Ethernet: Similar to optical transport of I/Q data from BBU to RRH, I/Q data can be digitized and packetized for the transmissions over Ethernet. Radio over Ethernet (RoE) [206]–[209] defines the process of converting radio signal I/Q data to packets which can be transported over Ethernet. The main issues associated with the packetization process while encapsulating the I/Q data over the fronthaul link are: *i)* overhead, *ii)* packetization latency, and *iii)* scheduling delay. The packetization overhead results from the frame and packet headers. Therefore, to reduce the overhead, each frame must be created with the maximum I/Q data possible such that the overall number of packets and Ethernet frames is minimized. However, the larger frame sizes adds wait time for the data filling up the maximum frame size increasing the overall latency. Hence, reducing the latency requires the transmission of short frames.

The scheduling of Ethernet frames can provide multiplexing gain through resource sharing, however, the scheduling can incur queuing delays. Therefore, to achieve low latency the overhead, packetization latency, and scheduling delay must be carefully considered. Chang et al. [178] have evaluated the CRAN performance in terms of packetization and scheduling on the Ethernet fronthaul. For higher functional splits, e.g., splits along layer boundaries, for instance when the complete PHY layer is implemented in the RRH, or the complete MAC and PHY layers are implemented in RRH, an RRH Ethernet gateway has been introduced to perform the scheduling, aggregate the traffic from RRH nodes, and discard the packets which past their deadlines. For instance, look-ahead depth packetization packs channel estimation I/Q data such that the channel estimation data precedes regular payload data in the demodulation. That is, demodulation does not wait for all the frame I/Q data to process the I/Q data related to channel estimation.

In contrast, the prefetch method waits uniformly over all the I/Q data for the packetization to receive the Reference Signal (RS) symbols consisting of I/Q for channel estimation. More specifically, the prefetching is performed after the demodulation, and the packetization before scheduling the I/Q samples only when all the required RS symbols within the look-ahead depth buffer have received the RS symbols. Various scheduling policies were applied to study the impact of the packetization process based on first-come, first-served (FCFS), shortest processing time (SPT), least remaining bit (LRB), earliest due date (EDD), and least slack time (LST). The performance analysis provided insights towards maximum number of RRHs supported over the RRH link for a given Ethernet link capacity, packet size, scheduling policy, and functional split. The simulation results showed that packetization techniques (e.g., look-ahead depth and prefetch) while employing the scheduling policy LRB with packet discarding provided a significant multiplexing gain by supporting the maximum number of RRHs.

d) TDM-PON Dynamic Bandwidth Allocation: In a PON system, distributed Optical Network Units (ONUs) connects to a central Optical Line Terminal (OLT) via a shared optical

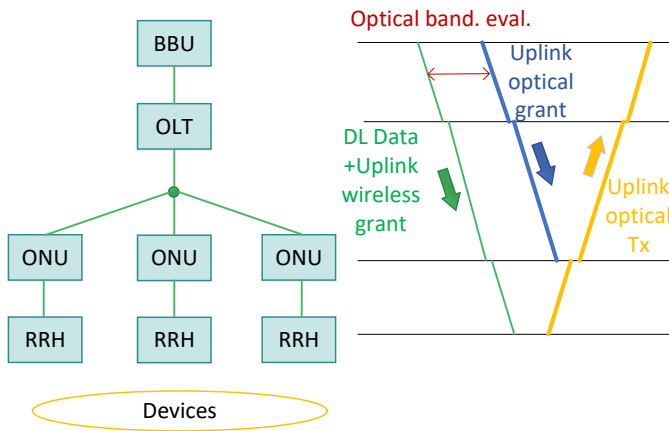

Fig. 34. DBA scheme optimizing latency: Grants for the optical transmissions are evaluated in advance and sent to ONUs based on the wireless uplink information which is known to the BBU [179].

fiber. The transmissions from the ONUs to the OLT are controlled by a scheduler implemented at the OLT. In a TDM-PON system, the OLT coordinates the transmissions from multiple ONUs such that there are no collisions on the shared fiber. The Dynamic Bandwidth Allocation (DBA) mechanism assigns the transmission resources to ONUs based on the QoS deadlines. For each DBA polling cycle, each ONU transmits a REPORT message indicating the queue size to the OLT. The OLT processes the REPORT messages from all ONUs to determine the transmission schedule. The transmission schedule is then sent to all the ONUs with GRANT messages indicating the exact transmission details for each specific ONU. This polling DBA mechanism consists of reporting the demands and waiting for the grants from centralized scheduler; therefore, typically, the total end-to-end PON delay is on the order of milliseconds [210], i.e., much higher than the fronthaul requirements of a few micro seconds. A PON system in the CRAN framework connects the RRHs to ONUs, and the BBU to the OLT. Thus, the BBU can schedule transmissions from the RRHs. Due to the PON delay characteristics, the PON system is not readily suitable for fronthaul application.

To address the PON delay, Tashiro et al. [179] have presented a novel DBA mechanism specifically for fronthaul applications. As the BBU assigns the grants for wireless upstream transmissions of the devices attached to an RRH (i.e., ONU), the RRH upstream bandwidth requirements are known at the BBU (i.e., OLT) ahead in time. In wireless LTE systems, the request reporting to grant reception (related to wireless scheduling) is separated by 4 ms in the protocol operations, similarly the grant reception to RF transmissions is separated by 4 ms. Hence, the total protocol delay from request to transmission is 8 ms. As illustrated in Fig. 34, concurrent to the grant evaluation for wireless transmissions, grants for the optical transmissions or the RRHs (i.e., ONUs) can also be evaluated and transmitted to the RRHs ahead of time, eliminating the report and grant cycle between ONUs and OLT. The experimental evaluation of TDM PON system with advance scheduling has demonstrated average end-to-end

latencies of less than $40 \mu\text{s}$, and packet jitters of less than $25 \mu\text{s}$ for fronthaul distances up to 20 km.

e) *Traffic Statistics Based Bandwidth Allocation*: Fixed Bandwidth Allocation (FBA) can address the overhead and scheduling delay incurred by the DBA mechanism, but fixed bandwidth allocations may waste resources due to over provisioning. For variable traffic, statistical multiplexing can be employed to increasing the bandwidth and resource utilization. Based on this principle, Kobayashi et al. [180] have proposed a TDM-PON bandwidth allocation scheme based on the traffic statistics of the variable fronthaul traffic. The proposed scheme considers the long term traffic characteristics on the order of several hours. The allocated bandwidth is then adapted based on the estimated long term mean and variance. The estimated bandwidth allocation is applied over the subsequent time period, and a new bandwidth allocation is estimated for each time period. The experimental results demonstrated end-to-end fronthaul latencies of $35 \mu\text{s}$, while the effective link bandwidth utilization was increased by 58% compared to FBA.

However, one of the shortcomings of the proposed bandwidth allocation based on traffic statistics is that it does not consider the specific fronthaul split option. For a traditional CRAN, where the RF I/Q samples are transported from RRH to BBU, a constant bit rate is required at all times; thus the FBA can efficiently meet the fronthaul requirements. Traffic variations according to varying user activity occur only for higher order functional CRAN splits. Therefore, traffic statistics based bandwidth allocation is limited to higher order functional split fronthaul designs.

f) *Summary and Lessons Learnt*: In a typical CRAN deployment where the RF I/Q is transported from RRH to BBU, the fronthaul traffic is independent of the user data which results in a constant bit rate over fronthaul links at all times to support the normal operations of BBU and RRH. Hence, there can be significant power consumption overhead for the CRAN deployment [211], [212]. Therefore, the new designs of fronthaul solutions should consider the overall energy consumption factor in addition to the end-to-end latency [213]. Several advanced physical layer techniques, such as, modulation, detection, and DSP (e.g., I/Q compression) for fiber transmissions have been proposed as part of energy efficient designs [214]–[216]. While the higher order functional split provide statistical multiplexing gain, the worst case delay must be analyzed to ensure that latency is within the delay budget of the fronthaul link. Fronthaul infrastructure is typically non-flexibly and must support the deployments of future 5G networks [217]. Therefore, the fronthaul designs, such as bandwidth allocation and resource sharing mechanism should be able to readily accommodate the new developments in the 5G technology. Although several techniques exist to mitigate the delay in fronthaul networks, there is no research efforts in addressing the synchronization of RRH and BBU to a universal timing. Flexible fronthaul techniques can be developed based on the reconfigurable network functions and physical layer entities such as modulators and transparent spectral converters in the framework of Software Defined Optical Networks (SDON) [218]. For instance, Cvijetic et al. [219] have proposed a SDN based topology-reconfigurable

optical fronthaul architecture. The dynamic reconfiguration of fronthaul can support low latency inter BS communications necessary for bidirectional Coordinated MultiPoint (CoMP) for inter-cell interference cancellation and inter-cell D2D.

3) Backhaul:

a) *Integrated Fronthaul and Backhaul:* The backhaul connects Radio Access Networks (RANs) to core networks, e.g., the LTE backhaul connects the RAN eNB node (base station) to the Evolved Packet Core (EPC) core network. Typically, in CRAN technology, the RRH only implements a split part of the eNB functions, for instance, the eNB PHY layer is implemented at the RRH, while the MAC and higher layers are implemented at the BBU. Thus, the RRH, the BBU, and the fronthaul connecting them, jointly constitute an eNB. Thus, if the endpoints of a link in a 5G network are the RRH and BBU, then the link operates as a fronthaul. On the other hand, if the endpoints are the eNB and EPC, then the link operates as a backhaul. With the centralization of the computing in the core network, such as in a CRAN, the BBU and EPC can be implemented at a single physical location which enables the deployment of a common infrastructure in an architecture to support both eNBs and RRHs over a common platform.

The crosshaul (Xhaul) architecture [171] provides a common platform to support both fronthaul and backhaul using an Xhaul transport network. In the SDN framework, the Xhaul transport network provides reconfigurability while operating over heterogeneous switches and links, such as microwave, mmWave, optical, and high speed Ethernet. In an effort to ensure the ULL capability of configurable integrated fronthaul and backhaul networks, Li et al. [220] have proposed an X-Ethernet based on Flexible Ethernet [221] technology for the Xhaul architecture. The experimental demonstration of X-Ethernet has demonstrated an average latency of 640 ns as compared to 30–50 μ s in a traditional Ethernet switch, indicating that X-Ethernet can be deployed as a part of the Xhaul data plane. As the control plane latency of X-Ethernet for reconfigurations has not been identified, the overall suitability of X-Ethernet for Xhaul needs further investigations.

b) *MillimeterWave (mmWave) Backhaul:* Millimeter-Wave (mmWave) radio technology for wireless communications operates in the spectrum between 30 and 300 GHz [190]. mmWaves have relatively short wavelengths and thus suffer pronounced signal attenuation with propagation distance and due to obstacles. Also, mmWaves exhibit high directionality. Therefore, mmWave technology exploits beamforming by focusing the signal energy in a narrow spatial beam to support longer propagation distances. The high attenuation property of mmWave signals facilitates geographical frequency reuse; thus saving the operators spectrum resources by avoiding co-channel interference. The availability of high bandwidths in the mmWave spectrum can achieve high capacity links which are suitable for both fronthaul and backhaul. However, the suitability of mmWave for the fronthaul latency requirements still needs to be examined. On the other hand, mmWave technology can readily support backhaul links.

Gao et al. [181] have presented a mmWave based backhaul for 5G using massive-MIMO to support a high number of

radio nodes, i.e., Base Stations (BSs). The proposed approach exploits Beam Division Multiplexing (BDM) whereby an independent beam is dedicated to a BS, thus creating a backhaul link through spatial multiplexing. Each mmWave beam supports a high capacity link, hence, a Time Division Multiplexing (TDM) scheduling can be employed to share the resources within a single beam, supporting multiple BSs over a single link. However, the scheduling of BDM resources with TDM can incur significant end-to-end latency as compared to BDM without TDM, and therefore must be carefully evaluated specific to the backhaul latency requirements.

c) *In-band millimeterWave (mmWave) Backhaul:* In-band mmWave technique shares the spectrum resources with the wireless access (i.e., BS to device), and backhaul (i.e., BS to BS and BS to core network). Since the wireless access and backhaul resources compete over the same spectrum resources in the in-band communication, there can be significant overhead in terms of capacity and latency. To analyze the in-band mmWave communications in terms of capacity, Taori et al. [182] have conducted a feasibility study and showed 25% resources of the mmWave link is sufficient to support the user data rates over the wireless link up to 0.8 Gbps. Typically, in the in-band backhaul connectivity, the resources are shared in TDM fashion between wireless and backhaul applications impacting both wireless and backhaul end-to-end connectivity during congestion. Although the suitability of in-band communication is justified in terms of capacity, the implications of in-band communication on the latency has not been characterized, and hence can compromise the performance of entire end-to-end connectivity if not carefully considered. Taori et al. [182] have also proposed a point-to-multipoint transmission for BS to BS (inter-BS) communication based on in-band mmWave backhaul connectivity. Inter-BS communication is necessary to support mobility features such as handover and redirection, as well as advanced radio features, such as inter cell interference cancellation using Coordinated MultiPoint (CoMP) and self organizing networks. As the deployments of BS increase to meet the capacity demands through small cells, the demand for coordination among neighboring BSs will increase. Hence, Inter-BS communication is an important aspect of 5G that needs to be addressed in a flexible, simple and cost effective manner. In-band mmWave connectivity provides a cost effective solution for inter-BS connectivity along with the flexibility due to a wireless connection, as compared to physical deployment of optical infrastructure. Point-to-multiple mmWave connectivity results in a simpler and cost effective solution through a dynamic reconfiguration of mmWave links based on the requirements.

d) *TCP over 5G mmWave Links:* mmWave links have typically high bandwidths, but are prone to outages as they require Line-of-Sight (LoS). Thus, there are high chances for temporary link disruptions, which can result in temporary congestion. TCP congestion control mechanism could negatively impact the overall capacity and the latency when a link is interrupted temporarily as a result of buffer bloating. Active Queue Management (AQM) can be applied to adaptively drop packets from the queue such that the queue size is contained for a particular flow to keep the end-to-end delay on average

within a threshold. Control Delay (CoDel) [222] is an AQM technique which ensures the lowest packet sojourn delay, i.e., packet delay from ingress to egress. Each packet is time-stamped at the ingress and elapsed time is evaluated for the packet drop decision, ensuring the minimum queue delay for a particular flow. The time interval between packet drops is reduced inversely proportional to the square root of the number of drops to achieve linear throughput variations in relation to the drop count.

To investigate the impact of temporary 5G mmWave link disruptions on end-to-end network connections, Pieska et al. [183] have evaluated the TCP performance studying the tradeoff between capacity and latency. The evaluation indicated that the disruption duration and frequency directly impact the TCP performance in addition to the aggressiveness of the TCP variant, such as TCP Reno, TCP Illinois, TCP cubic, and TCP Scalable. Although CoDel is a promising technique in curtailing the buffer bloat in regular TCP networks, Non-LoS (NLOS) occurrences of a mmWave link can result in significant throughput loss in case of TCP over mmWave link due to extensive CoDel packet dropping, especially for a single flow of the TCP Reno variant. However, the evaluations indicated that CoDel can achieve low latency and fast recovery for flows with low RTT and disruption duration. Nevertheless, to avoid the implications of buffer bloat, new TCP designs should be able to accommodate short link disruptions specifically for 5G mmWave connectivity for access, fronthaul, and backhaul.

e) Summary and Lessons Learnt: With the ever increasing capacity demands, there are growing requirements for infrastructure deployments, particularly in access networks. Small cells where the devices are close to the radio nodes are widely adopted to save power and to offload the burden on the macro wireless cells [223]. However, the small cell traffic needs to be eventually aggregated at the backhaul, resulting in demanding requirements for the small cell connectivity with the core networks. The connectivity can be provided through fiber backhaul links that can be shared through FiWi techniques among multiple wireless nodes [161]. mmWave technology is another promising technology for meeting the high bandwidth and ULL requirements for next generation connectivity, such as, small cell backhaul supporting 5G, and fronthaul and backhaul sharing [224]. As compared to the power consumption of optical communications, the power consumption of mmWave links is typically significantly higher due to the scattering of wireless transmissions as compared to the guided optical waves in an fiber. Therefore, mmWave requires new energy efficient methods in resource management and shared backhaul and fronthaul for 5G applications.

In contrast, optical wireless [225] utilizes the visible light for communications with similar characteristics as mmWave. In addition to the directionality (LoS) and spatial multiplexing properties, optical wireless suffers from interferences due to ambient light sources. Similar to mmWave designs, the system design should be robust to accommodate disruptions due to temporary link obstructions. Future designs should also ensure synchronization on the order of 65 ns [106], [164], [226] while supporting the shared fronthaul and backhaul.

4) Network Management: ULL mechanisms are closely related to network management for meeting the flow demands in terms of resource allocation, reliability, congestion control, and end-to-end QoS. The increasing number of protocols that support the fronthaul and backhaul connectivity in a single end-to-end path creates a heterogeneous environment. The comprehensive (end-to-end) management of this heterogeneous network environment can be complex without the support of an inter-operative mechanism. Management mechanisms based on Software Defined Network (SDN) could provide a single platform for the coordination of multitude of protocols.

a) Integrated Fronthaul and Backhaul Architecture: Both Distributed-RAN (DRAN) and CRAN offer unique deployment options for cellular operators to enable cellular connectivity to the users. DRAN conducts the baseband signal processing at the remote Base Station (BS). As a result the BS to core network (backhaul) connectivity has relaxed QoS requirements and thus can be leased in the access network domain. On the other hand, CRAN requires dedicated fiber links (typically owned by the cellular operator) for connecting the radio nodes to the core network. Therefore, 5G networks are expected to uniformly support DRAN and CRAN architectures in enable cellular connectivity to the users.

Jungnickel et al. [184] have proposed an integrated fronthaul and backhaul based on SDN to commonly support DRAN and CRAN deployments for cellular operators. Traditional Ethernet deployment strategies [227], such as the E-tree, can be adapted for the CRAN, and the E-LAN for D-RAN based on their topology support. To utilize the existing fiber, independent wavelengths can be used to meet the latency and capacity requirements of the fronthaul and backhaul. For example, the backhaul can use TDM within a single wavelength that is shared among multiple radio nodes, and the fronthaul requires a dedicated wavelength between radio node and CRAN. However, the sharing of traditional access networks in E-Tree and E-LAN mode can cause security issues. Nevertheless, SDN provides both flexibility of statistical multiplexing in both the optical and electrical domains, and security through the virtualization of the network infrastructure. In a similar study, Ameigeiras et al. [228] have proposed a hierarchical SDN architecture based on virtualization, as well as Ethernet and IPv6 technologies focusing on low latency.

b) Optical Wireless Networking: The inter-working of optical and wireless technologies has been explored in FiWi networks [200]. As next generation applications demands ULL and high reliability, there is a greater need to integrate optical and wireless technologies with minimal impact on the traditional cellular infrastructures, such as 4G LTE. Towards this end, the 5G STEP-FWD project [167] has been funded by the European Commission to develop novel networking solutions that closely integrate the optical and wireless technologies within the 5G framework.

Vardakas et al. [167] have proposed a high capacity and low latency 5G backhaul architecture as illustrated in Fig. 35. Network densification is supported by small cells which are connected to macro BSs through PONs, mainly: *i)* Optical Line Terminals (OLTs) connected through fiber links, *ii)*

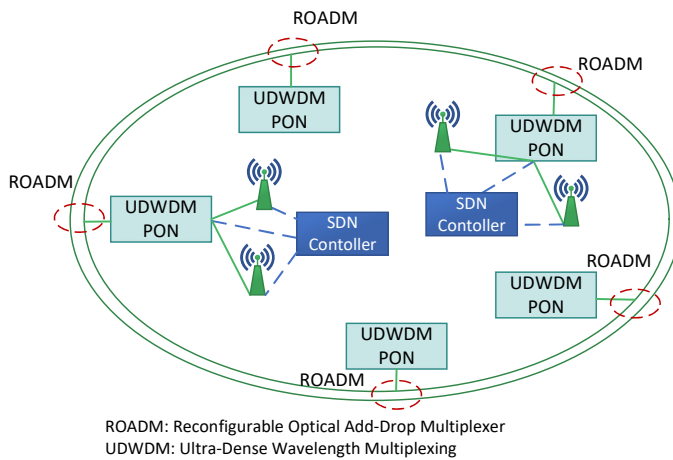

Fig. 35. Simplified version of ULL optical wireless architecture where WDM ring connects to wireless nodes and SDN controller through PON framework [167].

point-to-point dedicated links, and *iii*) local Optical Network Units (ONUs) connections through fiber protection ring offered by dark fiber. The dark fiber utilization provides a cost effective solution as the infrastructure already exists. The wireless access by the small cells and backhaul connectivity supported by PONs are controlled by a unified SDN management framework. mmWave-UDWDM technology effectively utilizes the wavelength and space division multiplexing, while PONs provide effective backhaul connectivity. The SDN management can support dynamic reconfigurability to support advanced network features, such as self-organization and self-healing for ultra-reliable infrastructure networks.

c) SDN Based Evolved Packet Core (EPC) Networks:

Pagé et al. [185] have presented an SDN architecture for the LTE Evolved Packet Core (EPC) to support low-latency towards an evolutionary 5G core network. OpenFlow technology has been integrated into the switching nodes that connect the BSs (i.e., eNBs) to the EPC. The advantages of SDN based switching include reduced need for protocol based transport services, such as GTP, elimination of the Serving-Gateway (S-GW) which conventionally provides flow based services, such as buffering and connection management. In contrast to the conventional LTE backhaul connectivity, where the S-GW anchors the connections of the eNBs to the P-GW, the SDN based EPC is managed by an SDN controller, which replaces the S-GW control plane functions. The S-GW data plane functions are replaced by the SDN supported switching nodes. Thus, the SDN architecture eliminates the data and control bearer based connectivity [229] by replacing the large GTP messages with small SDN control messages. Additionally, the SDN based switching nodes can assist in attach and mobility procedures to reduce the overall load on the EPC core. As a result, the overall end-to-end latency can be reduced by reducing the data plane and control plane latency introduced by the intermediate nodes in the EPC core.

d) Dynamic Gateway Placement: Lakkakorpi et al. [186] have proposed a low latency technique in an SDN based backhaul network architecture that is fully reconfigurable. The

gateway functions and queue management are configured to achieve low latency by minimizing the flow reestablishment procedures. The SDN controller dynamically programs the switching nodes to implement the network functions based on the flow characteristics. More specifically, an anchor switching node is dynamically selected to implement the gateway functions and AQM based on the flow mobility characteristics. For instance, in case of frequent handovers, the flow path must be often reconfigured to pass from one gateway function node to another. Therefore, the gateway functions can be implemented deeper in the core networks for the specific flows with frequent handovers, such that only the path routing is updated during handovers. This implementation of the gateway functions in the core networks also distributes the gateway functions across the switching nodes, reducing the overall burden on the core network.

e) Summary and Lessons Learnt: In addition to the optimization of handover latencies in the wireless access, the backhaul architecture should also support lower handover latencies. Chen et al. [230] have discussed the need for efficient backhaul architecture to support ultra-short handover latencies. However, the discussions are limited to DBA mechanisms in PONs for optimizing the LTE X2 and S1 interfaces.

In 5G technology, handovers can cause temporary disruptions to large data flows which can result in buffer-bloat problems across the network. New congestion control mechanisms must be adapted for to address the short and temporary disruptions due to handovers during the large data transfers. SDN based strategies can help to address these challenging handover problems [231]. However, existing studies have not considered the control plane latency and complexity, which may significantly impact the overall end-to-end latency. Therefore while ensuring the flexibility and reliability in 5G networks, it is also important to consider the end-to-end latency, through infrastructure based solutions, such as, dense wavelength-division multiplexed (DWDM) optical ring transport networks [232] using dark fiber, which is both energy and cost efficient.

5) Discussion on ULL 5G Research Efforts: There have been numerous research efforts in the wireless access segment of 5G networks. However, there is still a need for research to solve compelling technical challenges [233] in enabling enabling ultra-reliable ULL communication. These research challenges include infrastructure reuse, as well as cost and power efficiency.

With the radio node densification, user mobility between radio nodes is expected to increase dramatically, which can significantly increase the control plane complexity in terms of user context updates in the core networks. Therefore, a light weight (i.e., reduced user context) user information set must be managed by the core networks, as opposed to intense policy and security mechanisms that contribute to control plane complexity. End-to-end security can reduce the burden of security measures by the core network. Similarly, user activities can be tracked by the radio node to enforce the policy and QoS measures across the network.

SDN plays an important role in not only for managing fronthaul, backhaul, and core networks, but also for greatly

reducing the network complexity by reducing the network function implementation in dedicated entities, such as policy enforcement and user authentication. SDN can also integrate the heterogeneous protocol operations through dynamic packet header manipulation such that the overhead from protocols is minimized.

Content caching in edge nodes has been widely discussed for reducing the delivery latency in the fog-RAN and edge computing domains [234]–[237]. SDN provides a platform for caching content across the entire network as well as based on user demands, optimizing both content caching and latency. Although 5G technology is primarily focused on power optimization of user devices and wireless radio nodes [238]–[240], the overall energy consumption of the network responsible for the end-to-end packet delivery should also be considered in future designs.

VIII. DATA CENTER NETWORKS

A. Data Center Network ULL Standardization Efforts

In this section we present a brief overview of the standardization efforts for Data Center Bridging (DCB), also known as Converged Enhanced Ethernet (CEE) and Data Center Ethernet (DCE), which target ULL requirements. The Addressing and DCB TG as part of the 802.1 WG focuses on standardizing two main areas: 1) addressing protocols for distributing local and multicast MAC addresses within bridged LANs, and 2) the DCB standardization that extends and provides enhancements to the existing 802.1 bridge specification targeted towards data centers. The main motivation behind the DCB standards is to provide a converged network where all applications run over a single shared physical infrastructure, i.e., Converged Network Approach (CNA), as opposed to the previous Disparate Network Approach (DNA) approach of having application-specific networks run over different link-layer technologies, e.g., Fiber Channel for Storage-Area Networks (SANs), InfiniBand for High-Performance Computing (HPC), and Ethernet for LAN connectivity and network management.

The benefits of CNA datacenter networks include: 1) management and maintenance simplification, 2) reliable and deterministic transport over Ethernet as the underlying data-link technology, 3) low capital and operating expenditure (CAPEX and OPEX) as well as space requirements due to the usage of common adapters, switches, and cables, etc [241], [242]. In addition to supporting application-specific traffic on a single converged network, DCB can support both TSN and non-TSN traffic in shared datacenter environments. In particular, the TG has published a number of standards that provide lossless Ethernet services to 802.1 bridges which we proceed to briefly review.

1) *Priority-based Flow Control (PFC)*: Priority-based Flow Control [37], [243, Section 36] (PFC) facilitates fine-grained link level flow control within 802.1 bridges for datacenter environments so as to assure near-zero frame loss due to lack of buffer space or bursty traffic. In particular, PFC controls, i.e., stops, the transmission of frames associated with one or more priorities, referred to as Classes of Service (CoSs), for a specified amount of time; there are eight CoSs in the

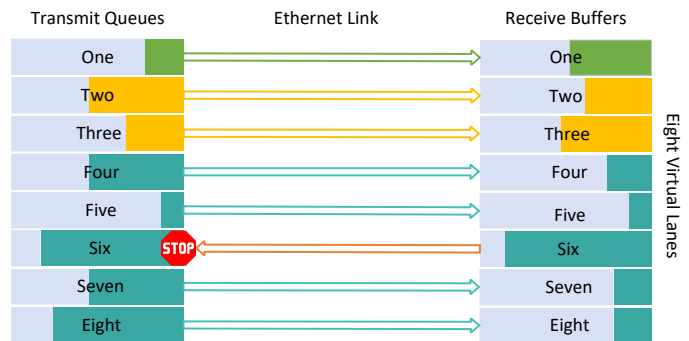

Fig. 36. Priority Based Flow-Control (PFC) [241], [243]: IEEE 802.3 PAUSE frame with extended PFC data is sent to the upstream station requesting the 6th priority level to stop transmission.

case of 802.1Q. PFC is defined only for a pair of directly connected peers using full duplex MACs, e.g., IEEE 802.3 MACs operating in point-to-point full duplex mode, to eliminate frame loss due to congestion for loss sensitive protocols, e.g., FCoE, whilst sharing the same network with traditional loss-insensitive protocols. Also, DCB is limited to datacenter networks of limited extent due to the impact of PFC on congestion spreading behavior, i.e., inhibiting transmission of non-PFC (disabled PFC) flows, which can occur when mixing PFC and non-PFC priorities in the same queue. The PFC operation is similar to 802.3 PAUSE frames [244], but operates on individual 802.1Q frame priority levels. Essentially, PFC extends the 802.3 PAUSE frame with two PFC fields: 1) an 8 bit mask that specifies which 802.1 priority level should be paused, and 2) a timer value specifying the length of time the traffic flow associated with the specific priority level should be stopped. The operation is governed by the direct peer receiver that sends an 802.3 PAUSE frame with extended PFC data, as illustrated in Fig. 36. After the bridge receives the request, the bridge blocks (pauses) all outgoing frames with the identified priorities to the receiver. When the requested timer expires, the bridge resumes transmission of the paused frames. Note that while certain frames are paused, proper buffer management is required to store the paused frames long enough for congestion to dissipate. Utilizing Congestion Notification (CN), see Section VIII-A2, can reduce the frequency with which PFC is invoked by proactively sending congestion notifications [243].

2) *Congestion Notification (CN)*: Congestion management and Notification [37], [245, Section 30-33] (CN), also known as Quantized Congestion Notification (QCN) strives to keep the core network congestion-free and push congestion towards the edge. CN is a layer 2 protocol that provides end-to-end congestion management for protocols that do not already have congestion control mechanisms built in, e.g., FCoE. CN operates within a Congestion Notification Domain (CND), i.e., all the network entities must adhere to the congestion management and notification protocol. CN instructs network entities through Congestion Notification Messages (CNMs) to throttle individual upstream flows to mitigate queue congestion downstream. Unlike PFC where the notification request flows to one device at a time, CN finds and signals congestion information to the source of the traffic congestion, i.e., the

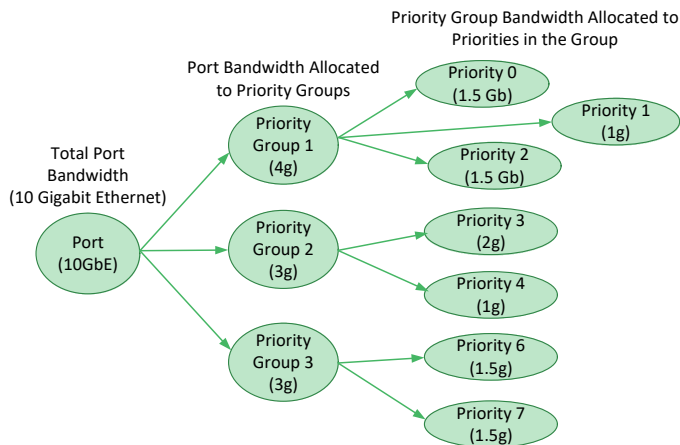

Fig. 37. Enhanced Transmission Selection (ETS) [242], [246]: The port/link bandwidth is divided between the traffic groups and further into traffic classes belonging to each group, creating a bandwidth allocation hierarchy.

edge device (end host). CN can benefit native congestion management protocols, such as TCP, by reducing the reaction time to congestion.

3) *Enhanced Transmission Selection (ETS)*: Since datacenter network traffic is highly diverse, the IEEE 802.1 DCB TG has proposed a priority-based Enhanced Transmission Selection (ETS) mechanism. ETS [37], [246, Section 37] provides a common management framework for assigning port bandwidth to traffic classes (CoSs) belonging to defined priority groups, where key ETS parameters are passed between network entities using the DCBX (see section VIII-A4) protocol. Each traffic class is allocated a percentage of available bandwidth on the data link between directly connected peers, as illustrated in Fig. 37. If a traffic class does not use its allocated bandwidth, ETS allows other traffic classes to use the available bandwidth to ensure efficient link utilization and guarantees a minimum amount of bandwidth to every flow.

4) *Data Center Bridging eXchange (DCBX)*: The Data Center Bridging eXchange (DCBX) protocol [37], [247, Section 38] enables DCB devices to exchange configuration parameters and state information with directly connected peers. DCBX is a discovery and capability exchange protocol mainly for conveying capabilities and DCB specifications (e.g., PFC, CN, and ETS) between neighbors to ensure consistent configuration across the network. For example, DCBX can be used to determine if two linked peer devices support PFC. Additionally, DCBX can be used to detect misconfiguration of a particular feature or parameter, e.g., priority groups in ETS, between linked peers. Furthermore, a DCBX device can use the information from its peer to configure its own DCB features to match the configuration of its linked peer. DCBX consists of DCB application Type-Length-Value (TLV) settings that are carried over Link Layer Discovery Protocol (LLDP) packets. Thus, DCBX leverages and extends functionality provided by IEEE 802.1AB [248] LLDP.

5) *Discussion on DCB Standardization Efforts*: Historically, TCP has been (and still is) a very popular method for reliable IP-based transport. However, L2 Ethernet has evolved with the addition of DCB extensions, e.g., PFC,

TABLE VI
DCB FEATURES AND BENEFITS [241]

Feature		Benefit
Priority-based Flow Control (PFC)	Flow	Provides capability to manage bursty single traffic source on a multi-protocol link
Enhanced Transm. Selection (ETS)	Se-	Enables bandwidth mgt. between traffic types for multi-protocol links
Congestion Noti. (CN)	(CN)	Addresses sustained conges. problem by moving corrective action to the edge net.
DCB Exch. Proto. (DCBX)	Proto.	Allows auto-exchange of Ethernet parameters between switches and endpoints

CN, ETS, DCBX, see Sections VIII-A1, VIII-A2, VIII-A3, and VIII-A4 respectively. This evolved L2 Ethernet protocol suite can provide reliability and fine-grained bandwidth allocation without the TCP overhead. The evolved Ethernet is a viable framework for data transport in data center environments, specifically storage and clustering applications, where transmission rates are high. Moreover, DCB enables near zero packet loss, eliminating TCP slow-start and thus allowing flow transmission at near multi-gigabit line-rates. In general, the amount of lossless traffic that an evolved Ethernet network can accommodate depends on several network characteristics, such as bandwidth, traffic load, frame size, and physical distances between devices. Table VI summarizes the added Ethernet extensions and the associated benefits to Datacenter Bridging [241].

Although the DCB Ethernet extensions target modern datacenter networks, the combination of TSN enabled mechanisms with certain DCB specifications (e.g., PFC or CN) need to be investigated. Several mechanisms specified by the 802.1 TSN TG already enable deterministic robust communication that eliminates congestion. In particular, would there be any merit in applying the PFC or CN DCB mechanisms when TSN mechanisms, e.g., the Time-Aware Shaper (TAS), Cyclic Queuing and Forwarding (CQF), and Per-Stream Filtering and Policing (PSFP) (see Section III-D), can eliminate congestion without the need to throttle or exchange congestion notification messages, thus reducing control data overhead and complexity?

B. Data Center ULL Networks Research Studies

Datacenter architectures and related protocol designs continue to be a major focal point in the research literature. Several surveys have focused on DCNs specifically targeting energy efficiency, cost, and DCN/Edge-Fog architectural evolution [288]–[293]. Similarly, [294], [295] survey optical interconnects (all-optical and hybrid) in DCN with emphasis on connectivity, scalability, and power/cost ratio consumption. In terms of datacenter virtualization and cloud computing, [296]–[299] survey recent solutions and architectures, i.e., topological designs and networking techniques that attempt to mitigate multi-tenant DCN responsiveness in addition to scalability issues for cloud-based DCN. Chen et al. [300] have focused on the hardware aspects of DCN, including architectural components and qualitative/quantitative discussions and trends on future DCNs in terms of performance comparisons among typical DCN topology designs, connectivity, bandwidth calculation, and diameter estimation. In terms of transport protocols,

DCN ULL Research Efforts, Sec. VIII-B

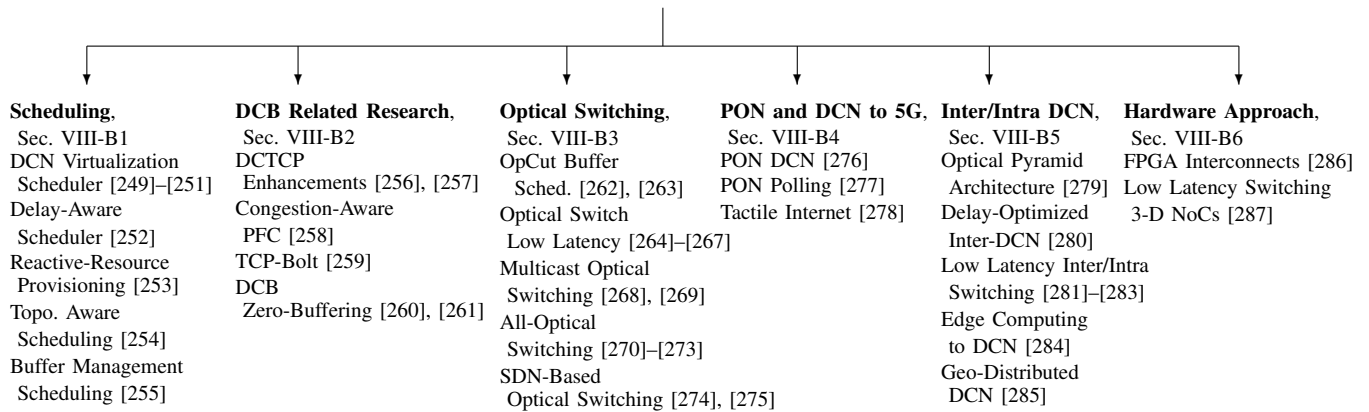

Fig. 38. Classification taxonomy ULL research efforts

specifically TCP, in DCN, [301]–[304] have surveyed recent solutions related to TCP as the reliable transport protocol, e.g., many-to-one incast transmission congestion, outcast (unfairness), latency (Flow Completion Time, FCT), delayed ACK, and routing/path selection problems. Liu et al. [305] have recently surveyed the literature with strict emphasis on latency, e.g., mean and tail FCT, in DCNs, specifically on reducing queue lengths, accelerating retransmissions, prioritizing mice flows, and exploiting multi-path routes. Relative to the existing surveys, this section will mainly focus on recent (since 2013) ULL focused studies based on the taxonomy illustrated in Fig. 38.

1) *Scheduling*: Scheduling is a key ULL research area in datacenter switches that arbitrate between different flows contending for the same output channel. Similarly, network virtualization is common in modern cloud and datacenter architectures. However, the schedulers in popular hypervisors/Virtual Machine Monitors (VMMs), e.g., Xen’s credit-based scheduler [306], incur increased communication latencies between co-located Virtual Machines (VMs). Therefore, Guan et al. [249] have designed and implemented a Communication-aware Inter-VM Scheduling (CIVSched) scheme that schedules network packets between VM tenants whilst taking into account the communication behavior between the VMs. Specifically, CIVSched inspects packets sent between local co-resident VMs and preferentially schedules the target VM while identifying the target process to reduce intra-VM latency.

Additionally, the recent emergence of SDN-based designs featuring decoupled data and control planes with centralized orchestration and control have prompted DCN scheduling re-designs. For example, Cao et al [250] have presented an SDN-based orchestrator that controls, i.e., virtualizes, schedules, and coordinates, the provisioning of Virtual Data Centers (VDCs) within Micro-DC (M-DC) that are equipped with Optical Burst Switching (OBS) ring topologies for intra-communication and OBS over wavelength optical networking paradigm for inter-communication between geographically distributed M-DCs. The SDN-based scheduling design can scale up or down depending on the QoS and load of the users while also taking into account the total scalar distance/number of hops to reduce

latency due to geographical location. Similar scheduler designs to shape traffic or provision resources according to dynamic conditions, predictive models, and traffic characteristics in order to improve scalability and to reduce latency have been investigated in [251]–[255].

2) *DCB Related Research*: Enabling DCB, see Section VIII-A, broadly on arbitrary networks with irregular topologies and without special traffic engineering/routing may cause large buffering delays, unfairness, HoL blocking, and deadlock. To mitigate these effects and to improve FCT, i.e., to add ULL properties, Stephens et al. [259] have developed TCP-Bolt, a TCP derivative for DCNs. TCP-Bolt extends DCTCP [307], which was designed for short (2-8 kbyte flows), to efficiently serve medium flows (64 kbyte–16MB). TCP-Bolt serves these medium flows with low queue occupancy by proactively probing the network for congestion while eliminating TCP slow-start and retransmissions. Stephens et al. have designed an Edge-Disjoint Spanning Trees (EDSTs) algorithm to prevent deadlocks and to ensure that all paths within the DCN are isolated. Similarly, addressing congestion control and management in DCNs, Avci et al. [258] have proposed and evaluated a Congestion Aware Priority Flow Control (CaPFC) link layer mechanism to proactively control congestion in DCB networks, see Section VIII-A. CaPFC monitors both ingress and egress queues using per-input counters at each egress port, as opposed to PFC (see Section VIII-A1) which monitors only ingress ports. CaPFC proactively prevents egress buffer overflows that causes Head of the Line (HoL) blocking and the spread of congestion across the network. Similar studies have examined methods to improve Data Center TCP (DCTCP), the de-facto transport protocol in DCNs, and improve known weaknesses in the DCB standardization, including efficient/optimized congestion control and Active Queuing/Buffer Management (AQM) [256], [257], [260], [261], [308].

3) *Optical Switching*: Conventional small scale DCs deploy purely electronic switching, which is cost efficient and easier to install than optical DCN interconnects. However electronic switching has significantly less bandwidth capacity, higher latencies, and higher signal attenuation than optical communication. Due to the proliferation and advantages of pure optical

interconnect in modern high performance computing (HPC) DCNs, Liu et al. [262] have investigated packet scheduling, including an adaptive pipelining scheme, in low latency Optical Cut-through (OpCut) switches that avoid conversion overhead from optical-electrical-optical (OEO) conversions. The scheduling emulates a “Virtual Input Queue” (VIQ) where each packet is timestamped and sent to an auxiliary array maintained in each receiver buffer, enabling practical search by the receiver for each timestamped packet. Similarly, Liu et al. [263] extends [262] with an in-order packet scheduler utilizing Wavelength Division Multiplexing (WDM). Liu et al. have developed an approximation algorithm that maintains packet order and approximates the optimal scheduling within a constant factor linear timing complexity.

Guo et al. [268] have proposed Guaranteed Latency Multicast Scheduling (GLMS), a high-speed multicast scheduling scheme, for hybrid optical packet switches in datacenter networks. GLMS strives to guarantee a maximum latency bound for all transmitted packets in OpCut switches. GLMS considers the schedule of each arriving packet for multiple time slots and subsequently transmits the packet. If the transmission fails, i.e., fails to cut-through, then the packet is buffered for future transmissions. GLMS guarantees latency bounds through *i*) cut-through scheduling, and *ii*) buffer scheduling. Furthermore, pipelines and parallel operation in GLMS relax the scheduling time constraint, reducing the timing complexity to make line-rate scheduling practically feasible. Similarly, Guo et al. [269] have investigated input-buffered multicast scheduling in all-optical interconnects. Guo et al. have proposed an optical buffer based on multicast-enabled fiber-delay-lines (M-FDL), that enables flexible packet duplication and controllable delays in buffered multicast switching. Similarly [264] has proposed optical switching designs for DCNs that minimize latency and power consumption.

Motivated by the limitations of modern DCNs, e.g., bandwidth bottlenecks, high latencies, manual operation, and poor scalability, specifically with the ubiquitous use of all Optical Packet/Circuit Switching (OPS & OCS), Perello et al. [270] have surveyed state-of-the-art DCN solutions, specifically targeting HPC and Big Data applications. The European project LIGHTNESS [272], [273] is highlighted by Perello et al in regards to the SDN-based unified control plane architecture. Similar articles have demonstrated the use of all-optical interconnects, specifically with the LIGHTNESS DCN solution [271]–[273], while other studies have examined DCN solutions for hybrid OPS and OCS in multi-tenant virtualization [275] and SDN-based flow management for low latency applications [265], [274].

4) *PON and DCN to 5G*: The upcoming Tactile Internet (TI) adds a new dimension to the 5G based mobile Internet. The TI vision requires ULL with extremely high availability, reliability and security. To this end, Wong et al. [278] have combined time and wavelength division multiplexing (TWDM) with Passive Optical LAN (TWDM-POL) to provide end-to-end ULL for real-time haptic delivery. The combined network includes a predictive resource allocation algorithm, the Tactile Internet capable Dynamic Wavelength and Bandwidth Allocation Algorithm (TI-DWBA), that controls/steers

TI (latency sensitive) and non-TI traffic within the Central Office (CO) dedicated server.

Furthermore, Passive Optical Networks (PONs) are used extensively between Internet Service Providers (ISPs) and their customers. Addressing low latency requirements in PONs, Berisa et al. [277] have developed a PON low latency polling (LLP) mechanism. LLP decouples the in-band report messages from the upstream data transmission window and schedules them independently from the OLT such that the report message can arrive immediately before a grant is sent by the OLT. Similarly, Gong et al. [276] have developed an architecture that replaces conventional ToR electronic switches with PON interconnects that utilize the advantages of PONs, i.e., higher efficient bandwidth, and lower latencies, within DCNs.

5) *Inter/Intra DCN*: Classical interconnections within and between DCs, i.e., intra/inter traffic, employ hierarchical topologies. The top layer, i.e., the high performance core switch, is usually connected to several aggregation switches that are further interconnected to several Top-of-Rack (ToR) switches on server racks. As an alternative to this classical hierarchical DC topology, Yuang et al. [279] have developed the Optical Pyramid Data Center Architecture (OPMDC). POMDC is based on Wavelength Selective Switch (WSS)-based optical switching nodes. OPMDC enables scalable and high bandwidth, low latency, as well as reduced power consumption and wiring complexity in HPC DCNs.

Similarly, addressing inter-datacenter traffic QoS requirements, specifically latency-sensitive traffic, Liu et al. [280] have developed a centralized SDN based traffic engineering approach that strives for delay-optimized routing. Liu et al. have implemented their traffic engineering at the application layer (instead of the network layer to reduce complexity at low layers). Liu et al. explicitly route different flows between datacenters taking into account the latency requirement, and strive for sparse paths, i.e., one path per flow (two in rare cases), to improve protocol convergence and reduce timing complexity. Similar studies have addressed inter/intra communication for HPC applications [281], and low latency client-server traffic for geo-distributed DCNs [285], and DCN-to-Edge computing frameworks [284].

6) *Hardware Approach*: While software solutions present an attractive research trend due to the extensible and portable nature of software that minimizes cost and installation requirements, a hardware approach to DCN components can significantly improve QoS metrics. Identifying key bottlenecks, e.g., cost, space, and power, in the technological trends in Key-Value Stores (KVS) [309] within DCN servers, Lockwood et al. [286] have developed a unique approach of using programmable logic, i.e., Field Programmable Gate Arrays (FPGAs), to implement a ULL KVS. Compared to the typical software approach, the proposed FPGA base approach scales up to provide higher throughput while reducing latency and power consumption. Lockwood et al have introduced a new open standard message format, Open Compute Storage Message (OCSM), that reduces the overhead for data parsing and field extraction in hardware.

Rezaei et al. [287] have developed Fine-grained 3D Resource SHaring, “FRESH” to exploit the benefits of 3D tech-

nology inter-layer communication, specifically for Network-on-Chip (NoC) technology. FRESH leverages inter-layer communication by utilizing Through-Silicon Vias (TSVs), providing ULL and minimizing energy consumption for communication within a router's micro-architecture. FRESH operates by dynamically sharing links and crossbars between vertically adjacent routers effectively spreading router performance under a variety of traffic loads, i.e., elastic control.

7) *Discussion on DCB Research Efforts:* Datacenter networking components and related paradigms, both in hardware and software, continue to have significant impacts on research trends, and significant efforts are made to achieve ULL in DCNs. While traditional datacenter architectures may be satisfactory for the traditional use of communication and applications, the onset of IoT, M2M, Industry 4.0, and Tactile Internet have pushed the traditional DCNs to the limit in terms of QoS/QoE metrics (such as bandwidth, latency, and jitter), cost and over-provisioning capital, and space/power consumption.

Figure 38 summarizes the recent DCN research studies towards ULL requirements. Typically, many research studies focus slightly more on bandwidth capacity in DCNs due to the large scale data distribution and generation. However, recent studies have emphasized the importance of timely data delivery through enhanced technologies focusing on optical interconnects and PONs that deliver data with much higher QoS compared to conventional electronic technologies. Similarly, SDN-based designs have become centralized to simplify the DCN management, while incorporating sophisticated virtualization, scheduling and provisioning techniques.

While significant research efforts have enhanced DCN, integrating the 802.1 TSN (Section III) and DetNet (Section V) specifications with the enhanced DCN architectures and protocols should be explored in future research. For instance, effectively utilize the TSN flow control and management mechanisms (see Section III-D and III-C, respectively) has the potential to substantially improve the communication within and between DCNs.

IX. FUTURE WORK AND OUTLINE

In this section we discuss the main open TSN and DetNet research problems and outline directions for future research efforts in TSN and DetNet networks.

A. Time Sensitive Networks (TSN)

1) *Inter-Scheduler Coordination:* Time aware shapers implement local scheduling principles specific to each TSN node. The end-to-end time sensitive characteristics of a flow are established under the assumption that each TSN node in the flow path guarantees the time sensitive characteristics. However, if an intermediate TSN node fails to enforce the TSN characteristics due to overload, or due to scheduler or timing inaccuracies, the overall end-to-end flow characteristics can be compromised. This situation is may be more likely for TSN nodes that are positioned where multiple flows can aggregate as opposed to the edge nodes (that are traversed by only few flows).

To address this shortcoming, future research should develop a robust inter-scheduler coordination mechanism. The coordination mechanism should facilitate interactions between the time aware shapers in the TSN nodes in a flow path to ensure the overall end-to-end time sensitive characteristic of the flow. For instance, upon the frame reception at the destination, the overall end-to-end latency can be estimated and the information can be fed back to the nodes. The nodes can then establish a self performance profile of the TSN nodes. The interactions of the time aware shapers would enable inter-scheduler coordination such that each TSN node can guarantee the time sensitive scheduling relative to the end-to-end behavior of the flow path similar to time-triggered scheduling [63].

However, time-triggered scheduling depends on time synchronization to synchronously trigger the scheduling over the entire flow path. In contrast, the inter-scheduler coordination enables dynamic changes of the scheduler policies, such as timing adjustments of frame transmissions (i.e., to delay or advance the transmissions in the scheduled time slots) correcting the synchronization inaccuracy. Thus, the time aware scheduler depends not only on the time synchronization, but also on the end-to-end flow characteristics. The inter-scheduler coordination can be enabled through a centralized mechanism. For instance, an SDN based control can monitor the end-to-end characteristics of the flows, and configure the timing advances and corrections of the time aware schedulers at specific TSN nodes as required.

2) *In-band Control Plane Overhead:* Control plane data in TSN network corresponds to the data generated from the control functions, e.g., for setting up connections, synchronizing nodes, managing flows, and tearing down connections. The impact of control plane data in TSN networks has been largely ignored to date in research and standardization. Control plane traffic could be transported with the in-band connectivity of the high priority Control Data Traffic (CDT) class, which carries time critical information from data sources, such as sensors. However, the control plane traffic would then competes with the CDT traffic.

Resource reservations in TSN networks to enable the deterministic time-sensitive properties are typically estimated based on CDT traffic requirements. Since the control plane traffic rates are generally significantly lower than the CDT traffic, the in-band control plane traffic is generally ignored in the system design and resource reservations. However, new use TSN cases, such as robotics and automated drones, may require the establishment of short lived TSN flows with commensurate frequent triggering of control plane activities. Thus, new use cases may significantly increase control plane data traffic. Therefore, new resource reservations designs, especially for the in-band control plane data transport should consider both the control plane data traffic as well as the CDT traffic in evaluating the resource reservation requirements. We anticipate that it will be particularly challenging to ensure the requirements of the varying and dynamic control plane data as compared to the steady CDT traffic.

3) *Low Priority Deadline Traffic:* TSN nodes preempt an ongoing low priority frame transmission for transmitting

an incoming high priority frame to guarantee the absolute minimum TSN node transit delay of the high priority frame. Depending on the intensity of the high priority traffic, a low priority frame can be preempted several times. As a result, the end-to-end delay characteristics of the low priority traffic cannot be guaranteed as the preemption occurrences depend directly on the high priority traffic intensity. If the high priority traffic intensity is significantly higher than the low priority traffic intensity, then end-to-end delay of the low priority traffic can be greatly increased. Generally, low priority traffic carries delay sensitive data, that is less critical than high priority traffic data, but still should be delivered within a worst case deadline. In the current state of the art, there exists no mechanism in research nor standards to ensure the worst case end-to-end delay of low priority traffic under preemption.

Therefore, future research needs to develop new mechanisms to ensure a bounded worst case delay for low priority traffic in TSN networks. A key challenge in designing a bounded worst case delay for low priority traffic is to not degrade the performance of high priority traffic. Rather, the new mechanisms should opportunistically accommodate low priority traffic transmissions to meet a worst case deadline.

4) *Impact of Synchronization Inaccuracy*: Several techniques for improving the synchronization accuracy while minimizing the synchronization errors have been developed for TSN networks. However, there is a lack of studies that quantify the implications of synchronization inaccuracies on the TSN network performance in terms of end-to-end delay and throughput. For low cost devices which are typically employed in large scale networks and for remote applications in IoT scenarios, the synchronization may not be as accurate as for industrial and robotic applications. Due to synchronization errors in TSN nodes, the transmissions scheduled by the time-aware shaper over a particular time slot, can extend or advance to adjacent time slots, which can impact the overall scheduling mechanism in a TSN node. For instance, in a time-triggered network, where all the TSN nodes schedule a flow based on synchronized timing information, synchronization errors can offset the time-triggers which can miss the schedule of a very short frame depending on the timing offset duration. Therefore, the performance impact due to synchronization errors for multiple priority traffic classes, frame sizes, and timing offset durations requires a close investigation.

5) *Ingress and Egress Nodes for TSN*: TSN networks are typically implemented in closed environments, such as automotive and industrial environments. However, most use cases require external connectivity to inter-operate with other networks. So far, no mechanism exists for establishing a common platform for the inter-operation of TSN networks with external non-TSN networks.

We envision the inter-operation of TSN networks with non-TSN networks in two ways: *i*) centralized SDN management, and *ii*) ingress and egress for the TSN network. In case of the centralized SDN, a TSN flow outside the TSN network can be distinguished and apply for resource reservations to ensure the delay sensitive characteristics. In case of ingress and egress nodes, an outside flow that requires TSN properties while traversing through a TSN network can be identified and

configured over the entire flow path such that the end-to-end flow integrity is preserved.

6) *TSN Performance for 5G Fronthaul Applications*: Fronthaul networks transport the highly delay sensitive In-phase/Quadrature (I/Q) symbol information between the central base band processing units and the remote radio heads. Therefore, typical deployments prefer optical fiber to establish high capacity and low latency links. Although traditional Ethernet can meet the capacity requirements, delay requirements are challenging to achieve with Ethernet networks. However, due to time sensitive properties, TSN Ethernet is being considered as a potential candidate L2 protocol for 5G fronthaul applications as an alternative to the Common Public Radio Interface (CPRI) and eCPRI [165] protocols. The adoption of TSN for existing Ethernet infrastructures could result in significant capital and operating expenditures for new fiber deployments. But, the actual performance of TSN networks for fronthaul applications has not yet been investigated for the various fronthaul splits [198]. The PHY and sub-PHY splits require strict deadlines on the order of sub-microseconds. On the other hand, function splits in the MAC, Radio Resource Control (RRC), and higher cellular protocol layers relax the delay requirements to the order of milliseconds. A comprehensive performance evaluation considering the full range of aspects of fronthaul applications, such as relative performance between Ethernet Passive Optical Networks (EPONs) and TSN Ethernet, packetization, functional split, and fronthaul distances for a Cloud Radio Access Network (CRAN) system could provide deep insight towards deployment considerations for mobile operator networks. Generally, latency reductions for 5G wireless networks have begun to attract significant research interest, see e.g., [3], [32], [154]–[162], [187], [191], [192], [233], [234], [238], [310]–[327]. Investigating the combined impacts of the various latency reduction techniques in these emerging studies in conjunction with TSN based fronthaul will be a very important direction for future research.

7) *TSN Applied to Wide Area Networks*: The time-sensitive protocol mechanisms that are applied to micro-environments, such as automotive networks, can also be applied to macro-environments, such as Wide Area Networks (WANs). In most situations, the end-to-end network delay is dominated by the wait time in the queues (buffers) of intermediate forwarding nodes. With the TSN rules applied to nodes, the overall end-to-end delay of a flow over a WAN network can be significantly reduced. However, WAN networks typically handle large numbers of flows and operate at very large capacities, making the TSN flow management very challenging. Despite these challenges, WAN network should, in principle, be capable of supporting TSN characteristics for specific flows that require strict end-to-end latency bound, such as remote surgery in health-care applications, where a doctor could operate on a patient across the WAN network. One possible approach to handle the challenging flow management could be through SDN based control. The large geographical WAN area would likely require an SDN control hierarchy consisting of multiple control plane entities, such as, local and root controllers, as well an orchestrator.

B. Deterministic Networking (DetNet)

1) *Packet Replication and Elimination*: Packet replication inherently increases the flow reliability by increasing the probability of packet delivery to the end destination. Additionally, packet replication can reduce the overall end-to-end latency due to disjoint paths [150]. However, a major disadvantage of packet replication is the increase in the effective bandwidth required for a flow. The required bandwidth can be decreased by reducing the degree of replication, which can effectively reduce the reliability. Thus, a balance between bandwidth and degree of packet replication must be ensured to operate the network within the required bandwidth (capacity) and latency limitation.

Towards this end, we propose a reverse packet elimination mechanism in which the destination node triggers an instruction to the nodes in the reverse path to apply a packet drop action. For instance, consider the forward direction of a flow with four disjoint paths, i.e., each packet is replicated four times. These replicated packets traverse independently across the disjoint path through the network to reach the common end destination. We can assume that one packet will arrive earlier than the others, considering that multiple packets will likely arrive at the destination. In the current implementation, the other packets are discarded when they eventually arrive at the destination. Thus effective bandwidth is four fold increased in the forward direction.

In a DetNet/SDN framework, the destination node can be made aware of the exact nodes traversed by the different paths. That is, for a given path with node 0 denoting the source node and node n denoting the destination node, the destination node knows the $n-1$ intermediate nodes. If there is a sufficient bandwidth in reverse direction, the destination node can send a short drop-packet in the reverse direction on paths through which the destination nodes has not yet received the packets; upon reception drop-packet, the intermediate nodes drop the forward packet. This drop-packet would traverse through nodes $n-1, n-2, \dots$ backward towards the source node while applying the rule to drop until the drop-packet meets the forward packet. Thus, because of the reverse back propagation of the drop-packet, some of the forward direction bandwidth is freed up. In many networking scenarios, the ratio of uplink traffic to downlink traffic is low, and therefore the uplink can typically readily accommodate the reverse back propagation of the drop-packet. Future research would need to conduct a rigorous performance study of the proposed drop-packet approach for a wide range of network conditions, such as number of flows, relative delay in diversity paths, and numbers of intermediate paths can be investigated.

2) *Virtualization: L2 Independent Mechanisms*: Although DetNet focuses on the network layer (L3) and higher layers, DetNet relies on the time sensitive link layer (L2) to establish the deterministic L3 packet flow properties. Therefore, promoting DetNet mechanisms which are independent of the time sensitive link layer could result in the wide adoption of DetNet due to the simpler and more cost effective infrastructure support. For instance, packet replication and fragmentation does not require timing information and can

be implemented independently of the link layer. One way to achieve independence from the link layer is through Network Function Virtualization (NFV), which can dynamically scale the resource reservations based on the demands of the flows. However, such NFV mechanisms would require hypervisor and control plane management [328]. NFV also provides a platform for centralized control plane management through the SDN framework. Thus, through a unique combination of SDN and NFV, DetNet can be independently adapted to networks without time sensitive link layer properties.

3) *Inter-networking*: The DetNet inter-networking with an external network (i.e., a non-DetNet network) is still an open issue. Generally, a DetNet requires a centralized in-domain controller to establish an end-to-end packet flow. Therefore, if an external flow needs to traverse a DetNet network, the flow requirements must be configured within the DetNet network. Ingress and egress nodes could be introduced to manage the configurations for the incoming and outgoing external flows. In particular, an ingress node could perform admission control to make accept/reject decisions for flows. The ingress node would then also track and manage the packet flows. During this process, ingress node could cooperate with the DetNet centralized control entity (e.g., a Path Computing Element (PCE)) to accomplish the flow setup over the DetNet network. Thus, the cooperation between ingress node and PCE would enable the inter-networking of the DetNet and non-DetNet networks. Of particular importance will be the study of interactions with data center networks. Latency reduction techniques for data center networks have received increasing attention in recent years, see for instance [249], [252]–[254], [256], [258], [262]–[264], [268]–[270], [277]–[280], [286], [287]. Thus, it will be important the extend DetNet into the data center networking domain.

4) *Application-adaptive Resource Reservations*: With the increasing number of applications requiring connectivity on the end user devices, the diversity of the traffic types has been increasing. Traditional data included voice and user-data, such as files and media, while the present data sources includes sensor data as well as tracking and analytics information. Time sensitive advanced applications in the automotive and industrial sectors requires special reservations of transmission resources to meet their ULL requirements. Therefore, we believe application-based resource reservations in L2 and PHY (i.e., proactive grants, periodic grants and semi-persistent scheduling) across the entire network are a promising technique to achieve the fundamental limits of ULL end-to-end latency for the users.

5) *Integration and Support for 5G Backhaul Networks*: To meet the growing data demands by ubiquitous mobile devices, 5G networks are expected to increase the infrastructure deployments through small cells. The small cells are deployed close to the users/devices, such as in shopping malls, stadiums, and on university campuses. However, the deployment of large numbers of small cells increases the backhaul network complexity. Cellular backhaul for small cells requires deterministic latency for establishing secure IP layer connectivity with the core networks. Hence, DetNet can provide backhaul connectivity for the small cells in 5G networks.

However, the integration of DetNet at the protocol level (e.g., GPRS Tunneling Protocol (GTP) and IPSec) with the existing cellular networks is yet to be thoroughly investigated. Key challenge are to achieve the low complexity overall control plane management as well as to keep the impact on the existing 5G control plane minimal.

C. 5G Networks

1) *Seamless Networks Access*: Although 5G is envisioned to support ULL and high data rates in both the wireless air interface and the core networks, the seamless network access across multiple operators and connectivity technologies, such as cable and DSL networks, is still an open issue in terms of inter-networking functions. The inter-networking functions across multiple networks and technology domains must be able to negotiate the same set of services while the devices are operating in the 5G domain.

2) *Network Session Migration*: The current network connectivity technology trends, including the 5G technology, enumerate several network interfaces that concurrently connect a user device to different networks, such as WiFi, LTE, 3G, and Ethernet. However, the actual network characteristics of each interface change over time. For instance, in cellular communications the transmit power is proportional to the distance from the base stations. Hence due to device mobility, the transmit power varies based on the relative distance between base station and device. While there exists a static way of choosing the network interface based on application requirement [329], a dynamic selection based on the network interface characteristics in real time remains an open research challenge. Additionally, once a session is established over an interface, any changes in the network characteristics that impede the connection quality would negatively impact the end-to-end latency. To maintain low latencies, an active session should be handed over to a different interface without interrupting the session.

D. Data-Center Networks

1) *Cut-Through Switching with TSN/ULL in DCNs*: Cut-through optical and hybrid switching are increasingly used in modern DCNs to reduce latency. In particular, cut-through transmission is typically useful between two ports running at similar data rates, which is generally the case for intra-DCN transmissions but not for inter-DCNs transmissions. Integrating the TSN mechanisms with DCB into DCNs with cut-through transmission is challenging due to multiple concerns, including bit errors in headers since cut-through transmission skips the CRC check. Missed bit errors can potentially lead to incorrect forwarding, higher risk of congestion, and delay contract violations, and, to a lesser degree, to the security concerns when frames are visible to unauthorized recipients. Furthermore, Ethernet frames that use MAC service interfaces generally follow the store-and-forward approach, where each frame is received and sent as whole. Therefore, formal definitions on MAC service interfaces to receive and forward parts of a frame must be defined. Generally, cut-through switching is

used in highly traffic-engineered specialized networks. Therefore, the viability and applicability of cut-through switching integrated with TSN in DCNs that offer converged Ethernet lossless services with guaranteed latencies are key challenges that need further investigation.

2) *Micro-Virtual DCNs*: Recent advances in hardware, virtualization, and the advent of edge computing enable DCNs to be virtualized and strategically distributed geographically in so-called Micro-DCs. Micro-DCs reduce the latencies perceived by users. Integrating TSN mechanisms to achieve guaranteed ULL latencies in such distributed and highly scalable networks is a challenging task. Additionally, Micro-DCs enable seamless convergence of OT and IT by installing the micro-DCs on the factory floors. These local micro-DCs in conjunction with ULL edge networks can efficiently support complex OT and IT applications. Extensive performance studies are required to evaluate such a new computing and networking paradigm.

X. CONCLUSION

This survey has comprehensively covered networks supporting ultra-low latency (ULL) applications. Providing ULL support requires specialized network protocol mechanisms that have been standardized for the link layer in the IEEE Time Sensitive Networking (TSN) set of standards and for the network layer in the IETF DETERministic NETWORKing (DETNET) specifications. In addition, extensive research studies have begun to investigate in detail the performance characteristics and limitations of these link and network layer ULL mechanisms. Aside from this link and network layer perspective, extensive standardization and research efforts have approached ULL support from the perspective of the common wireless device-to-data center communication chain. In particular, the emerging fifth generation (5G) wireless systems as well as emerging data center systems provide extensive support mechanisms for ULL applications.

The survey has revealed numerous gaps and limitations of the existing ULL networking mechanisms that present a wide range of avenues for future research. Aside from addressing the limitations of the individual ULL support mechanisms, there is an urgent need to comprehensively evaluate the cooperation of the various developed ULL mechanisms. Judicious configuration and cooperation of the various ULL mechanisms will likely be critical for providing effective ULL services to the end users.

REFERENCES

- [1] M. Wollschlaeger, T. Sauter, and J. Jasperneite, "The future of industrial communication: Automation networks in the era of the Internet of Things and Industry 4.0," *IEEE Industrial Electronics Magazine*, vol. 11, no. 1, pp. 17–27, Mar. 2017.
- [2] G. P. Fettweis, "The tactile internet: Applications and challenges," *IEEE Vehicular Technology Magazine*, vol. 9, no. 1, pp. 64–70, Mar. 2014.
- [3] M. Maier, M. Chowdhury, B. P. Rimal, and D. P. Van, "The tactile Internet: Vision, recent progress, and open challenges," *IEEE Communications Magazine*, vol. 54, no. 5, pp. 138–145, May 2016.
- [4] A. Finzi, A. Mifdaoui, F. Frances, and E. Lochin, "Incorporating TSN/BLS in AFDX for mixed-criticality avionics applications: Specification and analysis," *arXiv preprint arXiv:1707.05538*, 2017.

- [5] P. Schulz, M. Matthe, H. Klessig, M. Simsek, G. Fettweis, J. Ansari, S. A. Ashraf, B. Almeroth, J. Voigt, I. Riedel, A. Puschmann, A. Mitschele-Thiel, M. Muller, T. Elste, and M. Windisch, "Latency critical IoT applications in 5G: Perspective on the design of radio interface and network architecture," *IEEE Communications Magazine*, vol. 55, no. 2, pp. 70–78, Feb. 2017.
- [6] D. Delaney, T. Ward, and S. McLoone, "On consistency and network latency in distributed interactive applications: A survey-Part I," *Presence: Teleoperators & Virtual Environments*, vol. 15, no. 2, pp. 218–234, Apr. 2006.
- [7] —, "On consistency and network latency in distributed interactive applications: A survey-Part II," *Presence: Teleoperators and Virtual Environments*, vol. 15, no. 4, pp. 465–482, Aug. 2006.
- [8] C. Bachhuber, E. Steinbach, M. Freundl, and M. Reisslein, "On the minimization of glass-to-glass and glass-to-algorithm delay in video communication," *IEEE Transactions on Multimedia*, vol. 20, no. 1, pp. 238–252, Jan. 2018.
- [9] B. Briscoe, A. Brunstrom, A. Petlund, D. Hayes, D. Ros, J. Tsang, S. Gjessing, G. Fairhurst, C. Griwodz, and M. Welzl, "Reducing internet latency: A survey of techniques and their merits," *IEEE Communications Surveys & Tutorials*, vol. 18, no. 3, pp. 2149–2196, Third Qu. 2016.
- [10] M. Lévesque and D. Tipper, "A survey of clock synchronization over packet-switched networks," *IEEE Communications Surveys & Tutorials*, vol. 18, no. 4, pp. 2926–2947, Fourth Qu. 2016.
- [11] Y. Luo, F. J. Effenberger, and N. Ansari, "Time synchronization over Ethernet passive optical networks," *IEEE Communications Magazine*, vol. 50, no. 10, pp. 136–142, Oct. 2012.
- [12] J. W. Guck, A. Van Bemten, M. Reisslein, and W. Kellerer, "Unicast QoS routing algorithms for SDN: A comprehensive survey and performance evaluation," *IEEE Communications Surveys & Tutorials*, vol. 20, no. 1, pp. 388–415, First Qu. 2018.
- [13] S. M. Laursen, P. Pop, and W. Steiner, "Routing optimization of AVB streams in TSN networks," *ACM SIGBED Review*, vol. 13, no. 4, pp. 43–48, Sep. 2016.
- [14] R. B. da Silva and E. S. Mota, "A survey on approaches to reduce BGP interdomain routing convergence delay on the internet," *IEEE Communications Surveys & Tutorials*, vol. 19, no. 4, pp. 2949–2984, Fourth Qu. 2017.
- [15] J. Luo, J. Jin, and F. Shan, "Standardization of low-latency TCP with explicit congestion notification: A survey," *IEEE Internet Computing*, vol. 21, no. 1, pp. 48–55, Jan.-Feb. 2017.
- [16] C. Xu, J. Zhao, and G. M. Muntean, "Congestion control design for multipath transport protocols: A survey," *IEEE Communications Surveys & Tutorials*, vol. 18, no. 4, pp. 2948–2969, Fourth Qu. 2016.
- [17] P. Mach and Z. Becvar, "Mobile edge computing: A survey on architecture and computation offloading," *IEEE Communications Surveys & Tutorials*, vol. 19, no. 3, pp. 1628–1656, Third Qu. 2017.
- [18] C. Mouradian, D. Naboulsi, S. Yangui, R. H. Glioth, M. J. Morrow, and P. A. Polakos, "A comprehensive survey on fog computing: State-of-the-art and research challenges," *IEEE Communications Surveys & Tutorials*, vol. 20, no. 1, pp. 416–464, First Qu. 2018.
- [19] J. Ni, K. Zhang, X. Lin, and X. S. Shen, "Securing fog computing for Internet of Things applications: Challenges and solutions," *IEEE Communications Surveys & Tutorials*, vol. 20, no. 1, pp. 601–628, First Qu. 2018.
- [20] T. Taleb, K. Samdanis, B. Mada, H. Flinck, S. Dutta, and D. Sabella, "On multi-access edge computing: A survey of the emerging 5G network edge cloud architecture and orchestration," *IEEE Communications Surveys & Tutorials*, vol. 19, no. 3, pp. 1657–1681, Third Qu. 2017.
- [21] I. Al-Anbagi, M. Erol-Kantarci, and H. T. Mouftah, "A survey on cross-layer quality-of-service approaches in WSNs for delay and reliability-aware applications," *IEEE Communications Surveys & Tutorials*, vol. 18, no. 1, pp. 525–552, First Qu. 2016.
- [22] M. Doudou, D. Djenouri, and N. Badache, "Survey on latency issues of asynchronous MAC protocols in delay-sensitive wireless sensor networks," *IEEE Communications Surveys & Tutorials*, vol. 15, no. 2, pp. 528–550, Second Qu. 2013.
- [23] R. Ford, M. Zhang, M. Mezzavilla, S. Dutta, S. Rangan, and M. Zorzi, "Achieving ultra-low latency in 5G millimeter wave cellular networks," *IEEE Communications Magazine*, vol. 55, no. 3, pp. 196–203, Mar. 2017.
- [24] P. Park, S. C. Ergen, C. Fischione, C. Lu, and K. H. Johansson, "Wireless network design for control systems: A survey," *IEEE Communications Surveys & Tutorials*, in print, vol. PP, no. 99, pp. 1–1, 2018.
- [25] I. Parvez, A. Rahmati, I. Guvenc, A. I. Sarwat, and H. Dai, "A survey on low latency towards 5G: RAN, core network and caching solutions," *arXiv preprint arXiv:1708.02562*, 2017.
- [26] G. Sutton, J. Zeng, R. Liu, W. Ni, D. Nguyen, B. Jayawickrama, X. Huang, M. Abolhasan, and Z. Zhang, "Enabling ultra-reliable and low latency communications through unlicensed spectrum," *IEEE Network*, in print, 2018.
- [27] M. Erol-Kantarci and H. T. Mouftah, "Energy-efficient information and communication infrastructures in the smart grid: A survey on interactions and open issues," *IEEE Communications Surveys & Tutorials*, vol. 17, no. 1, pp. 179–197, First Qu. 2015.
- [28] A. Badr, A. Khisti, W. T. Tan, and J. Apostolopoulos, "Perfecting protection for interactive multimedia: A survey of forward error correction for low-delay interactive applications," *IEEE Signal Processing Magazine*, vol. 34, no. 2, pp. 95–113, Mar. 2017.
- [29] A. Douik, S. Sorour, T. Y. Al-Naffouri, and M. S. Alouini, "Instantly decodable network coding: From centralized to device-to-device communications," *IEEE Communications Surveys & Tutorials*, vol. 19, no. 2, pp. 1201–1224, Second Qu. 2017.
- [30] M. Fidler and A. Rizk, "A guide to the stochastic network calculus," *IEEE Communications Surveys & Tutorials*, vol. 17, no. 1, pp. 92–105, First Qu. 2015.
- [31] A. Aijaz, M. Simsek, M. Dohler, and G. Fettweis, "Shaping 5G for the tactile internet," in *5G Mobile Communications*. Springer, Cham, Switzerland, 2017, pp. 677–691.
- [32] M. Simsek, A. Aijaz, M. Dohler, J. Sachs, and G. Fettweis, "5G-enabled tactile internet," *IEEE Journal on Selected Areas in Communications*, vol. 34, no. 3, pp. 460–473, Mar. 2016.
- [33] J. Eveleens, "Ethernet AVB overview and status," in *Proc. IEEE SMPTE Technical Conf. Exhibition*, Oct. 2014, pp. 1–11.
- [34] M. D. J. Teener, A. N. Fredette, C. Boiger, P. Klein, C. Gunther, D. Olsen, and K. Stanton, "Heterogeneous networks for audio and video: Using IEEE 802.1 audio video bridging," *Proceedings of the IEEE*, vol. 101, no. 11, pp. 2339–2354, Nov. 2013.
- [35] M. Amjad, M. H. Rehmani, and S. Mao, "Wireless multimedia cognitive radio networks: A comprehensive survey," *IEEE Communications Surveys & Tutorials*, in print, vol. PP, no. 99, pp. 1–1, 2018.
- [36] R. Trestian, I. S. Comsa, and M. F. Tuysuz, "Seamless multimedia delivery within a heterogeneous wireless networks environment: Are we there yet?" *IEEE Communications Surveys & Tutorials*, in print, vol. PP, no. 99, pp. 1–1, 2018.
- [37] "IEEE Standard for Local and metropolitan area networks—Bridges and Bridged Networks," *IEEE Std 802.1Q-2014 (Revision of IEEE Std 802.1Q-2011)*, pp. 1–1832, Dec. 2014.
- [38] R. M. Metcalfe and D. R. Boggs, "Ethernet: Distributed packet switching for local computer networks," *Communications of the ACM*, vol. 19, no. 7, pp. 395–404, Jul. 1976.
- [39] R. M. Metcalfe, "Computer/network interface design: Lessons from Arpanet and Ethernet," *IEEE Journal on Selected Areas in Communications*, vol. 11, no. 2, pp. 173–180, Feb. 1993.
- [40] "IEEE Standard for Local and Metropolitan Area Networks - Timing and Synchronization for Time-Sensitive Applications in Bridged Local Area Networks," *IEEE Std 802.1AS-2011*, pp. 1–292, Mar. 2011.
- [41] M. Holness, "IEEE Draft Standard for Local and metropolitan area networks—Media Access Control (MAC) Bridges and Virtual Bridged Local Area Networks Amendment: YANG Data Model," *IEEE P802.1Qcp/D0.7 December 2016*, Dec. 2016.
- [42] "IEEE Standard for Local and Metropolitan Area Networks—Virtual Bridged Local Area Networks Amendment 14: Stream Reservation Protocol (SRP)," *IEEE Std 802.1Qat-2010 (Revision of IEEE Std 802.1Q-2005)*, pp. 1–119, Sep. 2010.
- [43] "IEEE Draft Standard for Local and metropolitan area networks—Media Access Control (MAC) Bridges and Virtual Bridged Local Area Networks Amendment: Stream Reservation Protocol (SRP) Enhancements and Performance Improvements," *IEEE P802.1Qcc/D2.0, October 2017*, pp. 1–207, Jan. 2017.
- [44] N. Finn, "IEEE Draft Standard for Local and metropolitan area networks—Media Access Control (MAC) Bridges and Virtual Bridged Local Area Networks Amendment: Link-local Registration Protocol," *IEEE P802.1CS/D1.2 December 2017*, Dec. 2017.
- [45] "IEEE Standard for Local and Metropolitan Area Networks - Virtual Bridged Local Area Networks Amendment 12 Forwarding and Queuing Enhancements for Time-Sensitive Streams," *IEEE Std 802.1Qav-2009 (Amendment to IEEE Std 802.1Q-2005)*, pp. C1–72, Jan. 2009.
- [46] "IEEE Standard for Local and metropolitan area networks - Bridges and Bridged Networks - Amendment 25: Enhancements for Scheduled Traffic," *IEEE Std 802.1Qbv-2015 (Amendment to IEEE Std 802.1Q-*

- as amended by IEEE Std 802.1Qca-2015, IEEE Std 802.1Qcd-2015, and IEEE Std 802.1Q—/Cor 1-2015), pp. 1–57, Mar. 2016.
- [47] “IEEE Standard for Ethernet Amendment 5: Specification and Management Parameters for Interspersing Express Traffic,” *IEEE Std 802.3br-2016 (Amendment to IEEE Std 802.3-2015 as amended by IEEE Std 802.3bw-2015, IEEE Std 802.3by-2016, IEEE Std 802.3bq-2016, and IEEE Std 802.3bp-2016)*, pp. 1–58, Oct. 2016.
- [48] “IEEE Standard for Local and metropolitan area networks – Bridges and Bridged Networks – Amendment 26: Frame Preemption,” *IEEE Std 802.1Qbu-2016 (Amendment to IEEE Std 802.1Q-2014)*, pp. 1–52, Aug. 2016.
- [49] “IEEE Standard for Local and metropolitan area networks–Bridges and Bridged Networks–Amendment 29: Cyclic Queuing and Forwarding,” *IEEE Std 802.1Qch-2017 (Amendment to IEEE Std 802.1Q-2014 as amended by IEEE Std 802.1Qca-2015, IEEE Std 802.1Qcd(TM)-2015, IEEE Std 802.1Q-2014/Cor 1-2015, IEEE Std 802.1Qbv-2015, IEEE Std 802.1Qbu-2016, IEEE Std 802.1Qbz-2016, and IEEE Std 802.1Qci-2017)*, pp. 1–30, Jun. 2017.
- [50] J. Specht, “IEEE Draft Standard for Local and metropolitan area networks–Media Access Control (MAC) Bridges and Virtual Bridged Local Area Networks Amendment: Asynchronous Traffic Shaping,” *IEEE P802.1Qcr/D0.2, November 2017*, Nov. 2017.
- [51] “IEEE Standard for Local and metropolitan area networks–Frame Replication and Elimination for Reliability,” *IEEE Std 802.1CB-2017*, pp. 1–102, Oct. 2017.
- [52] “IEEE Standard for Local and metropolitan area networks–Bridges and Bridged Networks – Amendment 24: Path Control and Reservation,” *IEEE Std 802.1Qca-2015 (Amendment to IEEE Std 802.1Q— as amended by IEEE Std 802.1Qcd-2015 and IEEE Std 802.1Q—/Cor 1-2015)*, pp. 1–120, Mar. 2016.
- [53] “IEEE Standard for Local and metropolitan area networks–Bridges and Bridged Networks–Amendment 28: Per-Stream Filtering and Policing,” *IEEE Std 802.1Qci-2017 (Amendment to IEEE Std 802.1Q-2014 as amended by IEEE Std 802.1Qca-2015, IEEE Std 802.1Qcd-2015, IEEE Std 802.1Q-2014/Cor 1-2015, IEEE Std 802.1Qbv-2015, IEEE Std 802.1Qbu-2016, and IEEE Std 802.1Qbz-2016)*, pp. 1–65, Sep. 2017.
- [54] “IEEE Standard for a Precision Clock Synchronization Protocol for Networked Measurement and Control Systems,” *IEEE Std 1588-2008 (Revision of IEEE Std 1588-2002)*, pp. 1–300, Jul. 2008.
- [55] M. Bjorklund, “YANG - A Data Modeling Language for the Network Configuration Protocol (NETCONF),” RFC 6020, Oct. 2010. [Online]. Available: <https://rfc-editor.org/rfc/rfc6020.txt>
- [56] A. Bierman, “Guidelines for Authors and Reviewers of YANG Data Model Documents,” RFC 6087, Jan. 2011. [Online]. Available: <https://rfc-editor.org/rfc/rfc6087.txt>
- [57] R. Enns, M. Bjorklund, A. Bierman, and J. Schwluder, “Network Configuration Protocol (NETCONF),” RFC 6241, Jun. 2011. [Online]. Available: <https://rfc-editor.org/rfc/rfc6241.txt>
- [58] A. Bierman, M. Bjorklund, and K. Watsen, “RESTCONF Protocol,” RFC 8040, Jan. 2017. [Online]. Available: <https://rfc-editor.org/rfc/rfc8040.txt>
- [59] “IEEE Standard for Device Discovery, Connection Management, and Control Protocol for IEEE 1722(TM) Based Devices,” *IEEE Std 1722.1-2013*, pp. 1–366, Oct. 2013.
- [60] F. Chen, “Resource Allocation Protocol (RAP) based on LRP for Distributed Configuration of Time-Sensitive Streams,” 2017, <http://ieee802.org/1/files/public/docs2017/tsn-chen-RAP-whitepaper-0917-v01.pdf>.
- [61] J. Specht and S. Samii, “Urgency-based scheduler for time-sensitive switched ethernet networks,” in *Proc. IEEE Euromicro Conf. on Real-Time Systems*, Jul. 2016, pp. 75–85.
- [62] P. Pedreiras, P. Gai, L. Almeida, and G. C. Buttazzo, “FTT-Ethernet: A flexible real-time communication protocol that supports dynamic QoS management on Ethernet-based systems,” *IEEE Transactions on Industrial Informatics*, vol. 1, no. 3, pp. 162–172, Aug. 2005.
- [63] P. Meyer, T. Steinbach, F. Korf, and T. C. Schmidt, “Extending IEEE 802.1 AVB with time-triggered scheduling: A simulation study of the coexistence of synchronous and asynchronous traffic,” in *Proc. IEEE Vehicular Networking Conf. (VNC)*, 2013, pp. 47–54.
- [64] H. Zhang and D. Ferrari, “Rate-controlled service disciplines,” *Journal of High Speed Networks*, vol. 3, no. 4, pp. 389–412, 1994.
- [65] —, “Rate-controlled static-priority queueing,” in *Proc. IEEE Infocom*, 1993, pp. 227–236.
- [66] L. Georgiadis, R. Guérin, V. Peris, and K. N. Sivarajan, “Efficient network QoS provisioning based on per node traffic shaping,” *IEEE/ACM Transactions on Networking*, vol. 4, no. 4, pp. 482–501, Aug. 1996.
- [67] H. Kirrmann, K. Weber, O. Kleineberg, and H. Weibel, “HSR: Zero recovery time and low-cost redundancy for industrial ethernet (high availability seamless redundancy, IEC 62439-3),” in *Proc. IEEE Conf. on Emerging Technologies & Factory Automation (ETFA)*, 2009, pp. 1–4.
- [68] H. Kirrmann, M. Hansson, and P. Muri, “IEC 62439 PRP: Bumpless recovery for highly available, hard real-time industrial networks,” in *Proc. IEEE Conf. on Emerging Technologies and Factory Automation (ETFA)*, 2007, pp. 1396–1399.
- [69] D. Oran, “OSI IS-IS Intra-domain Routing Protocol,” RFC 1142, Feb. 1990. [Online]. Available: <https://rfc-editor.org/rfc/rfc1142.txt>
- [70] P. Unbehagen, N. Bragg, D. Allan, D. Fedyk, and P. J. Ashwood-Smith, “IS-IS Extensions Supporting IEEE 802.1aq Shortest Path Bridging,” RFC 6329, Apr. 2012. [Online]. Available: <https://rfc-editor.org/rfc/rfc6329.txt>
- [71] J. Farkas, N. Bragg, P. Unbehagen, G. Parsons, P. J. Ashwood-Smith, and C. Bowers, “IS-IS Path Control and Reservation,” RFC 7813, Jun. 2016. [Online]. Available: <https://rfc-editor.org/rfc/rfc7813.txt>
- [72] F. Bannour, S. Souihi, and A. Mellouk, “Distributed SDN control: Survey, taxonomy, and challenges,” *IEEE Communications Surveys & Tutorials*, vol. 20, no. 1, pp. 333–354, First Qu. 2018.
- [73] J. Vasseur, A. Farrel, and G. Ash, “A Path Computation Element (PCE)-Based Architecture,” RFC 4655, Aug. 2006. [Online]. Available: <https://rfc-editor.org/rfc/rfc4655.txt>
- [74] “IEEE Standard for Local and metropolitan area networks–Port-Based Network Access Control,” *IEEE Std 802.1X-2010 (Revision of IEEE Std 802.1X-2004)*, pp. 1–205, Feb 2010.
- [75] “IEEE Standard for Local and metropolitan area networks – Port-Based Network Access Control Amendment 1: MAC Security Key Agreement Protocol (MKA) Extensions,” *IEEE Std 802.1Xbx-2014 (Amendment to IEEE Std 802.1X-2010)*, pp. 1–107, Dec 2014.
- [76] “IEEE Standard for Local and Metropolitan Area Networks: Media Access Control (MAC) Security,” *IEEE Std 802.1AE-2006*, pp. 1–150, Aug 2006.
- [77] “IEEE Standard for Local and metropolitan area networks–Media Access Control (MAC) Security Amendment 1: Galois Counter Mode–Advanced Encryption Standard– 256 (GCM-AES-256) Cipher Suite,” *IEEE Std 802.1AEBn-2011 (Amendment to IEEE Std 802.1AE-2006)*, pp. 1–52, Oct 2011.
- [78] “IEEE Standard for Local and metropolitan area networksMedia Access Control (MAC) Security Amendment 2: Extended Packet Numbering,” *IEEE Std 802.1AEBw-2013 (Amendment to IEEE Std 802.1AE-2006)*, pp. 1–67, Feb 2013.
- [79] “IEEE Standard for Local and metropolitan area networks–Media Access Control (MAC) Security - Amendment 3:Ethernet Data Encryption devices,” *IEEE Std 802.1AECg-2017 (Amendment to IEEE Std 802.1AE-2006 as amended by IEEE Std 802.1AEBn-2011 and IEEE Std 802.1AEBw-2013)*, pp. 1–143, May 2017.
- [80] “IEEE Standard for Local and metropolitan area networks - Secure Device Identity,” *IEEE Std 802.1AR-2009*, pp. 1–77, Dec 2009.
- [81] M. Gutiérrez, W. Steiner, R. Dobrin, and S. Punnekkat, “Synchronization quality of IEEE 802.1 AS in large-scale industrial automation networks,” in *Proc. IEEE Real-Time and Embedded Technology and Applications Symposium (RTAS)*, 2017, pp. 273–282.
- [82] C. Liß, M. Ulbricht, U. F. Zia, and H. Müller, “Architecture of a synchronized low-latency network node targeted to research and education,” in *Proc. IEEE Int. Conf. on High Performance Switching and Routing*, Jun. 2017, pp. 1–7.
- [83] B. Noseworthy, “Network-based application-independent time-error and direct port latency measurement,” in *Proc. IEEE Int. Symp. on Precision Clock Synchronization for Measurement, Control, and Communication*, Sep. 2016, pp. 1–6.
- [84] D. Park, J. Lee, C. Park, and S. Park, “New automatic de-registration method utilizing a timer in the IEEE 802.1 TSN,” in *Proc. IEEE Int. Conf. on Computer Commun. and the Internet*, Oct. 2016, pp. 47–51.
- [85] F. A. R. Arif and T. S. Atia, “Load balancing routing in time-sensitive networks,” in *Proc. IEEE Int. Scientific-Practical Conf. Problems of Infocommunications Science and Technology*, Oct. 2016, pp. 207–208.
- [86] N. G. Nayak, F. Dürr, and K. Rothermel, “Software-defined environment for reconfigurable manufacturing systems,” in *Proc. IEEE Int. Conf. on the Internet of Things*, Oct. 2015, pp. 122–129.
- [87] S. Thangamuthu, N. Concer, P. J. L. Cuijpers, and J. J. Lukkien, “Analysis of ethernet-switch traffic shapers for in-vehicle networking applications,” in *Proc. IEEE Design, Automation Test in Europe Conf. Exhibition*, Mar. 2015, pp. 55–60.
- [88] M. H. Farzaneh and A. Knoll, “An ontology-based plug-and-play approach for in-vehicle time-sensitive networking (TSN),” in *Proc.*

- IEEE Information Technology, Electronics and Mobile Communication Conf.*, Oct. 2016, pp. 1–8.
- [89] J. Ko, J.-h. Lee, C. Park, and S.-k. Park, “Research on optimal bandwidth allocation for the scheduled traffic in IEEE 802.1 AVB,” in *Proc. IEEE Int. Conf. on Vehicular Electronics and Safety (ICVES)*, 2015, pp. 31–35.
- [90] L. L. Bello, “Novel trends in automotive networks: A perspective on ethernet and the IEEE audio video bridging,” in *Proc. IEEE Emerging Technology and Factory Automation*, Sep. 2014, pp. 1–8.
- [91] F. Dürr and N. G. Nayak, “No-wait packet scheduling for IEEE time-sensitive networks (TSN),” in *Proc. ACM Int. Conf. on Real-Time Networks and Systems*, 2016, pp. 203–212.
- [92] S. S. Craciunas, R. S. Oliver, M. Chmelifk, and W. Steiner, “Scheduling real-time communication in IEEE 802.1 Qbv time sensitive networks,” in *Proc. ACM Int. Conf. on Real-Time Networks and Systems*, 2016, pp. 183–192.
- [93] P. Pop, M. L. Raagaard, S. S. Craciunas, and W. Steiner, “Design optimisation of cyber-physical distributed systems using IEEE time-sensitive networks,” *IET Cyber-Physical Systems: Theory Applications*, vol. 1, no. 1, pp. 86–94, 2016.
- [94] F. Smirnov, M. Glaß, F. Reimann, and J. Teich, “Formal timing analysis of non-scheduled traffic in automotive scheduled TSN networks,” in *Proc. IEEE Design, Automation Test in Europe Conf. Exhibition*, Mar. 2017, pp. 1643–1646.
- [95] C. Park, J. Lee, T. Tan, and S. Park, “Simulation of scheduled traffic for the IEEE 802.1 time sensitive networking,” in *Information Science and Applications, LNEE Vol. 376*. Springer, Singapore, 2016, pp. 75–83.
- [96] H. Lee, J. Lee, C. Park, and S. Park, “Time-aware preemption to enhance the performance of audio/video bridging (AVB) in IEEE 802.1 TSN,” in *Proc. IEEE Int. Conf. on Computer Commun. and the Internet*, Oct. 2016, pp. 80–84.
- [97] D. Thiele and R. Ernst, “Formal worst-case performance analysis of time-sensitive ethernet with frame preemption,” in *Proc. IEEE 21st Int. Conf. on Emerging Techn. and Factory Automation (ETFA)*, 2016, pp. 1–9.
- [98] Z. Zhou, Y. Yan, S. Ruepp, and M. Berger, “Analysis and implementation of packet preemption for time sensitive networks,” in *Proc. IEEE Int. Conf. on High Performance Switching and Routing (HPSR)*, Jun. 2017, pp. 1–6.
- [99] S. Kehrer, O. Kleineberg, and D. Heffernan, “A comparison of fault-tolerance concepts for IEEE 802.1 time sensitive networks (TSN),” in *Proc. IEEE Emerging Technology and Factory Automation*, Sep. 2014, pp. 1–8.
- [100] S. Sommer, A. Camek, K. Becker, C. Buckl, A. Zirkler, L. Fiege, M. Armbruster, G. Spiegelberg, and A. Knoll, “RACE: A centralized platform computer based architecture for automotive applications,” in *Proc. IEEE Int. Elec. Vehi. Conf.*, 2013, pp. 1–6.
- [101] D. Cussans, “Trigger logic unit (tlu) design ready,” Advanced European Infrastructures for Detectors at Accelerators (AIDA-2020), AIDA-2020-MS43, Tech. Rep., Feb. 2017.
- [102] D. Thiele and R. Ernst, “Formal analysis based evaluation of software defined networking for time-sensitive ethernet,” in *Proc. Design, Automation Test in Europe Conf. Exhibition*, Mar. 2016, pp. 31–36.
- [103] D. Thiele, R. Ernst, and J. Diemer, “Formal worst-case timing analysis of ethernet TSN’s time-aware and peristaltic shapers,” in *Proc. IEEE Vehicular Networking Conference (VNC)*, 2015, pp. 251–258.
- [104] D. Thiele and R. Ernst, “Formal worst-case timing analysis of ethernet TSN’s burst-limiting shaper,” in *Proc. IEEE Design, Automation Test in Europe Conf. Exhibition*, Mar. 2016, pp. 187–192.
- [105] F. He, L. Zhao, and E. Li, “Impact analysis of flow shaping in Ethernet-AVB/TSN and AFDX from network calculus and simulation perspective,” *Sensors*, vol. 17, no. 5, pp. 1–33, 2017.
- [106] T. Wan and P. Ashwood-Smith, “A performance study of CPRI over Ethernet with IEEE 802.1Qbu and 802.1Qbv enhancements,” in *Proc. IEEE Globecom*, 2015, pp. 1–6.
- [107] S. S. Craciunas and R. S. Oliver, “An overview of scheduling mechanisms for time-sensitive networks,” Real-time Summer School, LEcole dEte Temps Reel (ETR), Tech. Rep., 2017.
- [108] —, “Combined task-and network-level scheduling for distributed time-triggered systems,” *Real-Time Systems*, vol. 52, no. 2, pp. 161–200, Mar. 2016.
- [109] H. Kopetz, A. Ademaj, P. Grillinger, and K. Steinhammer, “The time-triggered ethernet (TTE) design,” in *Proc. IEEE Int. Symp. on Object-Oriented Real-Time Distr. Computing (ISORC)*, 2005, pp. 22–33.
- [110] W. Steiner, G. Bauer, B. Hall, M. Paulitsch, and S. Varadarajan, “TTEthernet dataflow concept,” in *Proc. IEEE Int. Symp. on Network Computing and Applications (NCA)*, 2009, pp. 319–322.
- [111] T. Yamada and R. Nakano, “Job shop scheduling,” in *Genetic Algorithms in Engineering Systems, IEE Control Engineering Series 55*, A. Zalzal and P. Fleming, Eds. The Institution of Electrical Engineers, 1997, pp. 134–160.
- [112] F. Glover, “Tabu search—Part I,” *ORSA Journal on Computing*, vol. 1, no. 3, pp. 190–206, Summer 1989.
- [113] S. Rumpf, T. Steinbach, F. Korf, and T. C. Schmidt, “Software stacks for mixed-critical applications: Consolidating IEEE 802.1 AVB and time-triggered ethernet in next-generation automotive electronics,” in *IEEE Int. Conf. on Consumer Electronics—Berlin (ICCE-Berlin)*, 2014, pp. 14–18.
- [114] D. Maxim and Y.-Q. Song, “Delay analysis of AVB traffic in time-sensitive networks (TSN),” in *Proc. ACM Int. Conf. on Real-Time Networks and Systems (RTNS)*, Oct. 2017, pp. 18–27.
- [115] W.-K. Jia, G.-H. Liu, and Y.-C. Chen, “Performance evaluation of IEEE 802.1 Qbu: Experimental and simulation results,” in *Proc. IEEE Conf. on Local Computer Networks (LCN)*, 2013, pp. 659–662.
- [116] O. Kleineberg, P. Fröhlich, and D. Heffernan, “Fault-tolerant audio and video bridging (AVB) Ethernet: A novel method for redundant stream registration configuration,” in *Proc. IEEE Conf. on Emerging Technologies & Factory Automation (ETFA)*, 2012, pp. 1–8.
- [117] J. Lee and S. Park, “New interconnection methodology of TSNs using V2X communication,” in *Proc. IEEE Computing and Commun. Workshop and Conf.*, Jan. 2017, pp. 1–6.
- [118] Z. MacHardy, A. Khan, K. Obana, and S. Iwashina, “V2X access technologies: Regulation, research, and remaining challenges,” *IEEE Communications Surveys & Tutorials*, in print, vol. PP, no. 99, pp. 1–1, 2018.
- [119] M. H. Farzaneh, S. Shafaei, and A. Knoll, “Formally verifiable modeling of in-vehicle time-sensitive networks (TSN) based on logic programming,” in *Proc. IEEE Vehicular Networking Conference*, Dec. 2016, pp. 1–4.
- [120] P. Heise, F. Geyer, and R. Obermaier, “TSimNet: An industrial time sensitive networking simulation framework based on OMNeT++,” in *Proc. IEEE Int. Conf. on New Technologies, Mobility and Security*, Nov. 2016, pp. 1–5.
- [121] F. Groß, T. Steinbach, F. Korf, T. C. Schmidt, and B. Schwarz, “A hardware/software co-design approach for ethernet controllers to support time-triggered traffic in the upcoming IEEE TSN standards,” in *Proc. IEEE Int. Conf. on Consumer Electronics—Berlin*. IEEE, 2014, pp. 9–13.
- [122] E. W. Knightly and N. B. Shroff, “Admission control for statistical QoS: Theory and practice,” *IEEE Network*, vol. 13, no. 2, pp. 20–29, Mar/Apr 1999.
- [123] J. Liebeherr, D. E. Wrege, and D. Ferrari, “Exact admission control for networks with a bounded delay service,” *IEEE/ACM Transactions on Networking*, vol. 4, no. 6, pp. 885–901, Dec. 1996.
- [124] M. Reisslein and K. W. Ross, “Call admission for prerecorded sources with packet loss,” *IEEE Journal on Selected Areas in Communications*, vol. 15, no. 6, pp. 1167–1180, Aug. 1997.
- [125] M. Reisslein, K. W. Ross, and S. Rajagopal, “A framework for guaranteeing statistical QoS,” *IEEE/ACM Transactions on Networking*, vol. 10, no. 1, pp. 27–42, Feb. 2002.
- [126] Z.-L. Zhang, Z. Liu, J. Kurose, and D. Towsley, “Call admission control schemes under generalized processor sharing scheduling,” *Telecommunication Systems*, vol. 7, no. 1-3, pp. 125–152, Jun. 1997.
- [127] N. Finn, P. Thubert, B. Varga, and J. Farkas, “Deterministic Networking Architecture,” Internet Engineering Task Force, Internet-Draft draft-ietf-detnet-architecture-04, Oct. 2017, work in Progress. [Online]. Available: <https://datatracker.ietf.org/doc/html/draft-ietf-detnet-architecture-04>
- [128] X. Geng and M. Chen, “DetNet Configuration YANG Model,” Internet Engineering Task Force, Internet-Draft draft-geng-detnet-conf-yang-00, Oct. 2017, work in Progress. [Online]. Available: <https://datatracker.ietf.org/doc/html/draft-geng-detnet-conf-yang-00>
- [129] J. Korhonen, L. Andersson, Y. Jiang, N. Finn, B. Varga, J. Farkas, C. J. Bernardos, T. Mizrahi, and L. Berger, “DetNet Data Plane Encapsulation,” Internet Engineering Task Force, Internet-Draft draft-ietf-detnet-dp-sol-00, Oct. 2017, work in Progress. [Online]. Available: <https://datatracker.ietf.org/doc/html/draft-ietf-detnet-dp-sol-00>
- [130] D. Huang, “Single-path PREF,” Internet Engineering Task Force, Internet-Draft draft-huang-detnet-single-path-pref-00, Dec. 2017, work in Progress. [Online]. Available: <https://datatracker.ietf.org/doc/html/draft-huang-detnet-single-path-pref-00>
- [131] X. Geng and M. Chen, “IGP-TE Extensions for DetNet Information Distribution,” Internet Engineering Task Force, Internet-Draft draft-geng-detnet-info-distribution-01, Sep. 2017, work in

- Progress. [Online]. Available: <https://datatracker.ietf.org/doc/html/draft-geng-detnet-info-distribution-01>
- [132] J. Farkas, B. Varga, rodneycummings@ni.com, Y. Jiang, and Y. Zha, "DetNet Flow Information Model," Internet Engineering Task Force, Internet-Draft draft-ietf-detnet-flow-information-model-00, Jan. 2018, work in Progress. [Online]. Available: <https://datatracker.ietf.org/doc/html/draft-ietf-detnet-flow-information-model-00>
- [133] T. Mizrahi, E. Grossman, A. J. Hacker, S. Das, J. Dowdell, H. Austad, K. Stanton, and N. Finn, "Deterministic Networking (DetNet) Security Considerations," Internet Engineering Task Force, Internet-Draft draft-ietf-detnet-security-01, Oct. 2017, work in Progress. [Online]. Available: <https://datatracker.ietf.org/doc/html/draft-ietf-detnet-security-01>
- [134] E. Grossman, C. Gunther, P. Thubert, P. Wetterwald, J. Raymond, J. Korhonen, Y. Kaneko, S. Das, Y. Zha, B. Varga, J. Farkas, F.-J. Goetz, J. Schmitt, X. Vilajosana, T. Mahmoodi, S. Spirou, P. Vizarreta, D. Huang, X. Geng, D. Dujovne, and M. Seewald, "Deterministic Networking Use Cases," Internet Engineering Task Force, Internet-Draft draft-ietf-detnet-use-cases-13, Sep. 2017, work in Progress. [Online]. Available: <https://datatracker.ietf.org/doc/html/draft-ietf-detnet-use-cases-13>
- [135] P. Pate and S. Bryant, "Pseudo Wire Emulation Edge-to-Edge (PWE3) Architecture," RFC 3985, Mar. 2005. [Online]. Available: <https://rfc-editor.org/rfc/rfc3985.txt>
- [136] M. Lasserre and V. Kompella, "Virtual Private LAN Service (VPLS) Using Label Distribution Protocol (LDP) Signaling," RFC 4762, Jan. 2007. [Online]. Available: <https://rfc-editor.org/rfc/rfc4762.txt>
- [137] T. Eckert, G. Cauchie, W. Braun, and M. Menth, "Traffic Engineering for Bit Index Explicit Replication (BIER-TE)," Internet Engineering Task Force, Internet-Draft draft-ietf-bier-te-arch-00, Jan. 2018, work in Progress. [Online]. Available: <https://datatracker.ietf.org/doc/html/draft-ietf-bier-te-arch-00>
- [138] Y. Lee, D. Ceccarelli, T. Miyasaka, J. Shin, and K. koog Lee, "Requirements for Abstraction and Control of TE Networks," Internet Engineering Task Force, Internet-Draft draft-ietf-teas-actn-requirements-08, Jan. 2018, work in Progress. [Online]. Available: <https://datatracker.ietf.org/doc/html/draft-ietf-teas-actn-requirements-08>
- [139] E. Haleplidis, K. Pentikousis, S. Denazis, J. H. Salim, D. Meyer, and O. Koufopavlou, "Software-Defined Networking (SDN): Layers and Architecture Terminology," RFC 7426, Jan. 2015. [Online]. Available: <https://rfc-editor.org/rfc/rfc7426.txt>
- [140] V. Watson, A. Tellabi, J. Sasmannahausen, and X. Lou, "Interoperability and security challenges of Industry 4.0," in *INFORMATIK 2017*. Gesellschaft für Informatik, Bonn, Germany, 2017, pp. 973–985.
- [141] V. Roca, B. Teibi, C. Burdinat, T. Tran-Thai, and C. Thienot, "Block or convolutional AL-FEC codes? a performance comparison for robust low-latency communications," 2017.
- [142] S. Pandi, F. Gabriel, J. A. Cabrera, S. Wunderlich, M. Reisslein, and F. H. Fitzek, "PACE: Redundancy engineering in RLNC for low-latency communication," *IEEE Access*, vol. 5, pp. 20477–20493, 2017.
- [143] S. Wunderlich, J. A. Cabrera, F. H. Fitzek, and M. Reisslein, "Network coding in heterogeneous multicore IoT nodes with DAG scheduling of parallel matrix block operations," *IEEE Internet of Things Journal*, vol. 4, no. 4, pp. 917–933, 2017.
- [144] M. Nixon and T. Round Rock, "A comparison of WirelessHART and ISA100. 11a," *Whitepaper, Emerson Process Management*, pp. 1–36, 2012.
- [145] P. Thubert, M. R. Palattella, and T. Engel, "6TiSCH centralized scheduling: When SDN meet IoT," in *Proc. IEEE Conf. on Standards for Communications and Networking (CSCN)*, Oct. 2015, pp. 42–47.
- [146] R. T. Hermeto, A. Gallais, and F. Theoleyre, "Scheduling for IEEE802.15.4-TSCH and slow channel hopping MAC in low power industrial wireless networks: A survey," *Computer Communications*, vol. 114, pp. 84–105, Dec. 2017.
- [147] T. Qiu, N. Chen, K. Li, M. Atiqzaman, and W. Zhao, "How can heterogeneous internet of things build our future: A survey," *IEEE Communications Surveys & Tutorials*, in print, vol. PP, no. 99, pp. 1–1, 2018.
- [148] T. Watteyne, M. Palattella, and L. Grieco, "Using IEEE 802.15.4e time-slotted channel hopping (TSCH) in the Internet of Things (IoT): Problem Statement," RFC 7554, May 2015. [Online]. Available: <https://rfc-editor.org/rfc/rfc7554.txt>
- [149] P. Thubert, T. Watteyne, R. Struik, and M. Richardson, "An architecture for IPv6 over the TSCH mode of IEEE 802.15.4. draft-ietf-6tisch-architecture-10," *IETF Draft, March*, 2015.
- [150] J. d. Armas, P. Tuset, T. Chang, F. Adelantado, T. Watteyne, and X. Vilajosana, "Determinism through path diversity: Why packet replication makes sense," in *Proc. IEEE Int. Conf. on Intelligent Networking and Collaborative Systems*, Sep. 2016, pp. 150–154.
- [151] N. Bhusan, J. Li, D. Malladi, R. Gilmore, D. Brenner, A. Damjanovic, R. Sukhvasi, C. Patel, and S. Geirhofer, "Network densification: the dominant theme for wireless evolution into 5G," *IEEE Communications Magazine*, vol. 52, no. 2, pp. 82–89, 2014.
- [152] M. Agiwal, A. Roy, and N. Saxena, "Next generation 5G wireless networks: A comprehensive survey," *IEEE Communications Surveys & Tutorials*, vol. 18, no. 3, pp. 1617–1655, 2016.
- [153] E. Hossain and M. Hasan, "5G cellular: key enabling technologies and research challenges," *IEEE Instrumentation & Measurement Magazine*, vol. 18, no. 3, pp. 11–21, 2015.
- [154] S. Dutta, M. Mezzavilla, R. Ford, M. Zhang, S. Rangan, and M. Zorzi, "Frame structure design and analysis for millimeter wave cellular systems," *IEEE Transactions on Wireless Communications*, vol. 16, no. 3, pp. 1508–1522, Mar. 2017.
- [155] M. Luvisotto, Z. Pang, and D. Dzung, "Ultra high performance wireless control for critical applications: Challenges and directions," *IEEE Transactions on Industrial Informatics*, vol. 13, no. 3, pp. 1448–1459, Jun. 2017.
- [156] C. She, C. Yang, and T. Q. S. Quek, "Radio resource management for ultra-reliable and low-latency communications," *IEEE Communications Magazine*, vol. 55, no. 6, pp. 72–78, Jun. 2017.
- [157] G. Durisi, T. Koch, J. Östman, Y. Polyanskiy, and W. Yang, "Short-packet communications over multiple-antenna rayleigh-fading channels," *IEEE Transactions on Communications*, vol. 64, no. 2, pp. 618–629, Feb. 2016.
- [158] O. Ploder, N. Palaoro, B. Etzlinger, and A. Springer, "A cross-layer approach for ultra-low-latency machine type communication," in *Proc. IEEE ICC*, 2017, pp. 1–6.
- [159] P. Mogensen, K. Pajukoski, E. Tiirola, J. Vihriala, E. Lahetkangas, G. Berardinelli, F. M. Tavares, N. H. Mahmood, M. Lauridsen, D. Catania, and A. Cattoni, "Centimeter-wave concept for 5G ultra-dense small cells," in *Proc. IEEE VTC*, 2014, pp. 1–6.
- [160] F. Pflug and T. Fingscheidt, "Robust ultra-low latency soft-decision decoding of linear PCM audio," *IEEE Transactions on Audio, Speech, and Language Processing*, vol. 21, no. 11, pp. 2324–2336, Nov. 2013.
- [161] H. Beyranvand, M. Lvesque, M. Maier, J. A. Salehi, C. Verikoukis, and D. Tipper, "Toward 5G: FiWi enhanced LTE-A HetNets with reliable low-latency fiber backhaul sharing and WiFi offloading," *IEEE/ACM Transactions on Networking*, vol. 25, no. 2, pp. 690–707, Apr. 2017.
- [162] M. A. Lema, A. Laya, T. Mahmoodi, M. Cuevas, J. Sachs, J. Markendahl, and M. Dohler, "Business case and technology analysis for 5G low latency applications," *IEEE Access*, vol. 5, pp. 5917–5935, 2017.
- [163] "Low latency in 4.9G/5G: Solutions for millisecond latency," Nokia Corporation. [Online]. Available: https://onestore.nokia.com/asset/201407/Nokia_Low-latency_in_4dot9_and_5G_Networks_White_Paper_EN.pdf
- [164] "CPRI specification," Common Public Radio Interface. [Online]. Available: <http://www.cpri.info/>
- [165] A. De la Oliva, J. A. Hernández, D. Larrabeiti, and A. Azcorra, "An overview of the CPRI specification and its application to C-RAN-based LTE scenarios," *IEEE Communications Magazine*, vol. 54, no. 2, pp. 152–159, Feb. 2016.
- [166] P. Chanclou, A. Pizzinat, F. Le Clech, T.-L. Reedeker, Y. Lagadec, F. Saliou, B. Le Guyader, L. Guillo, Q. Deniel, S. Gosselin *et al.*, "Optical fiber solution for mobile fronthaul to achieve cloud radio access network," in *Proc. IEEE Future Network and Mobile Summit*, 2013, pp. 1–11.
- [167] J. S. Vardakas, I. T. Monroy, L. Wosinska, G. Agapiou, R. Brenot, N. Pleros, and C. Verikoukis, "Towards high capacity and low latency backhauling in 5G: The 5G STEP-FWD vision," in *Proc. IEEE Int. Conf. on Transparent Optical Networks*. IEEE, 2017, pp. 1–4.
- [168] P. Monti, Y. Li, J. Mårtensson, M. Fiorani, B. Skubic, Z. Ghebretensae, and L. Wosinska, "A flexible 5g ran architecture with dynamic baseband split distribution and configurable optical transport," in *Proc. IEEE Int. Conf. Transparent Optical Networks*. IEEE, 2017, pp. 1–1.
- [169] "Requirements for the eCPRI transport network v1.0," Common Public Radio Interface. [Online]. Available: http://www.cpri.info/downloads/Requirements_for_the_eCPRI_Transport_Network_V1_0_2017_10_24.pdf
- [170] "IEEE P802.1CM/D2.0 time-sensitive networking for fronthaul," LAN/MAN Standards Committee of the IEEE Computer Society. [Online]. Available: <http://www.ieee802.org/1/files/private/cm-drafts/d2/802-1CM-d2-0.pdf>
- [171] A. De La Oliva, X. C. Pérez, A. Azcorra, A. Di Giglio, F. Cavaliere, D. Tiegelbckers, J. Lessmann, T. Hausteina, A. Mourad, and P. Iovanna,

- “Xhaul: toward an integrated fronthaul/backhaul architecture in 5G networks,” *IEEE Wireless Communications*, vol. 22, no. 5, pp. 32–40, 2015.
- [172] “Next generation fronthaul interface (1914) working group,” IEEE. [Online]. Available: <http://sites.ieee.org/sagroups-1914>
- [173] “Control and user plane separation of EPC nodes (CUPS),” 3GPP. [Online]. Available: <http://www.3gpp.org/news-events/3gpp-news/1882-cups>
- [174] J. Kim, D. Kim, and S. Choi, “3GPP SA2 architecture and functions for 5G mobile communication system,” *ICT Express*, vol. 3, no. 1, pp. 1–8, 2017.
- [175] “3gpp specification series for 5g nr,” 3GPP. [Online]. Available: <http://www.3gpp.org/DynaReport/38-series.htm>
- [176] U. Habiba and E. Hossain, “Auction mechanisms for virtualization in 5G cellular networks: Basics, trends, and open challenges,” *IEEE Communications Surveys & Tutorials*, vol. PP, no. 99, pp. 1–1, 2018.
- [177] X. Liu, H. Zeng, N. Chand, and F. Effenberger, “Experimental demonstration of high-throughput low-latency mobile fronthaul supporting 48 20-MHz LTE signals with 59-gb/s CPRI-equivalent rate and 2- μ s processing latency,” in *Proc. IEEE European Conf. on Optical Communication*. IEEE, 2015, pp. 1–3.
- [178] C.-Y. Chang, N. Nikaiein, and T. Spyropoulos, “Impact of packetization and scheduling on C-RAN fronthaul performance,” in *Proc. IEEE GLOBECOM*. IEEE, 2016, pp. 1–7.
- [179] T. Tashiro, S. Kuwano, J. Terada, T. Kawamura, N. Tanaka, S. Shigematsu, and N. Yoshimoto, “A novel DBA scheme for TDM-PON based mobile fronthaul,” in *Optical Fiber Communications Conference and Exhibition (OFC)*, 2014. IEEE, 2014, pp. 1–3.
- [180] T. Kobayashi, D. Hisano, T. Shimada, J. Terada, A. Otaka *et al.*, “Bandwidth allocation scheme based on simple statistical traffic analysis for tdm-pon based mobile fronthaul,” in *Optical Fiber Communication Conference*. Optical Society of America, 2016, pp. W3C–7.
- [181] Z. Gao, L. Dai, D. Mi, Z. Wang, M. A. Imran, and M. Z. Shakir, “Mmwave massive-MIMO-based wireless backhaul for the 5G ultra-dense network,” *IEEE Wireless Communications*, vol. 22, no. 5, pp. 13–21, 2015.
- [182] R. Taori and A. Sridharan, “Point-to-multipoint in-band mmwave backhaul for 5G networks,” *IEEE Communications Magazine*, vol. 53, no. 1, pp. 195–201, 2015.
- [183] M. Pieska and A. Kessler, “Tcp performance over 5G mmWave linkstradeoff between capacity and latency,” in *Proc. IEEE Int. Conf. on Wireless and Mobile Computing, Networking and Communications*. IEEE, 2017, pp. 385–394.
- [184] V. Jungnickel, K. Habel, M. Parker, S. Walker, C. Bock, J. F. Riera, V. Marques, and D. Levi, “Software-defined open architecture for front-and backhaul in 5G mobile networks,” in *Proc. IEEE Int. Conf. Transparent Optical Networks*. IEEE, 2014, pp. 1–4.
- [185] J. Pagé and J.-M. Dricot, “Software-defined networking for low-latency 5G core network,” in *Proc. IEEE Int. Conf. Military Communications and Information Systems*. IEEE, 2016, pp. 1–7.
- [186] J. Lakkakorpi, H. Flinck, J. Heinonen, P. Korja, T. Partti, and K. Soranko, “Minimizing delays in mobile networks: With dynamic gateway placement and active queue management,” in *Wireless Days*. IEEE, 2016, pp. 1–3.
- [187] S. Nagata, L. H. Wang, and K. Takeda, “Industry perspectives,” *IEEE Wireless Communications*, vol. 24, no. 3, pp. 2–4, Jun. 2017.
- [188] P. K. Agyapong, M. Iwamura, D. Staehle, W. Kiess, and A. Benjebbour, “Design considerations for a 5G network architecture,” *IEEE Communications Magazine*, vol. 52, no. 11, pp. 65–75, 2014.
- [189] S. Parkvall, E. Dahlman, A. Furuskar, and M. Frenne, “NR: The new 5G radio access technology,” *IEEE Communications Standards Magazine*, no. 1, pp. 24–30, 2017.
- [190] S. A. Busari, K. M. S. Huq, S. Mumtaz, L. Dai, and J. Rodriguez, “Millimeter-Wave massive MIMO communication for future wireless systems: A survey,” *IEEE Communications Surveys & Tutorials*, in print, vol. PP, no. 99, pp. 1–1, 2018.
- [191] X. Meng, J. Li, D. Zhou, and D. Yang, “5G technology requirements and related test environments for evaluation,” *China Communications*, vol. 13, no. Supplement 2, pp. 42–51, 2016.
- [192] S. A. Ashraf, I. Aktas, E. Eriksson, K. W. Helmersson, and J. Ansari, “Ultra-reliable and low-latency communication for wireless factory automation: From LTE to 5G,” in *Proc. IEEE Int. Conf. Emerging Technologies and Factory Automation*, 2016, pp. 1–8.
- [193] A. Pizzinat, P. Chanclou, F. Saliou, and T. Diallo, “Things you should know about fronthaul,” *IEEE/OSA Journal of Lightwave Technology*, vol. 33, no. 5, pp. 1077–1083, 2015.
- [194] A. Checko, H. L. Christiansen, Y. Yan, L. Scolari, G. Kardaras, M. S. Berger, and L. Dittmann, “Cloud RAN for mobile networks technology overview,” *IEEE Communications surveys & tutorials*, vol. 17, no. 1, pp. 405–426, 2015.
- [195] D. Wubben, P. Rost, J. S. Bartelt, M. Lalam, V. Savin, M. Gorgoglione, A. Dekorsy, and G. Fettweis, “Benefits and impact of cloud computing on 5G signal processing: Flexible centralization through cloud-RAN,” *IEEE signal processing magazine*, vol. 31, no. 6, pp. 35–44, 2014.
- [196] J. Bartelt, P. Rost, D. Wubben, J. Lessmann, B. Melis, and G. Fettweis, “Fronthaul and backhaul requirements of flexibly centralized radio access networks,” *IEEE Wireless Communications*, vol. 22, no. 5, pp. 105–111, 2015.
- [197] I. A. Alimi, A. L. Teixeira, and P. P. Monteiro, “Towards an efficient C-RAN optical fronthaul for the future networks: A tutorial on technologies, requirements, challenges, and solutions,” *IEEE Communications Surveys & Tutorials*, vol. 20, no. 1, pp. 708–769, First Qu. 2018.
- [198] C.-Y. Chang, N. Nikaiein, R. Knopp, T. Spyropoulos, and S. S. Kumar, “FlexCRAN: A flexible functional split framework over ethernet fronthaul in cloud-RAN,” in *Proc. IEEE ICC*, 2017, pp. 1–7.
- [199] A. Rostami, P. Ohlen, K. Wang, Z. Ghebretensae, B. Skubic, M. Santos, and A. Vidal, “Orchestration of RAN and transport networks for 5G: An SDN approach,” *IEEE Communications Magazine*, vol. 55, no. 4, pp. 64–70, 2017.
- [200] F. Aurzada, M. Lévesque, M. Maier, and M. Reisslein, “FiWi access networks based on next-generation PON and gigabit-class WLAN technologies: A capacity and delay analysis,” *IEEE/ACM Transactions on Networking (ToN)*, vol. 22, no. 4, pp. 1176–1189, 2014.
- [201] A. M. Mikaeil, W. Hu, T. Ye, and S. B. Hussain, “Performance evaluation of XG-PON based mobile front-haul transport in cloud-RAN architecture,” *IEEE/OSA Journal of Optical Communications and Networking*, vol. 9, no. 11, pp. 984–994, 2017.
- [202] P. Chanclou, L. A. Neto, K. Grzybowski, Z. Tayq, F. Saliou, and N. Genay, “Mobile fronthaul architecture and technologies: A RAN equipment assessment,” *Journal of Optical Communications and Networking*, vol. 10, no. 1, pp. A1–A7, 2018.
- [203] J.-i. Kani, J. Terada, K.-I. Suzuki, and A. Otaka, “Solutions for future mobile fronthaul and access-network convergence,” *Journal of Lightwave Technology*, vol. 35, no. 3, pp. 527–534, 2017.
- [204] F. Saliou, G. Simon, P. Chanclou, M. Brunero, L. Marazzi, P. Parolari, M. Martinelli, R. Brenot, A. Maho, S. Barbet *et al.*, “Self-seeded RSOAs WDM PON field trial for business and mobile fronthaul applications,” in *Optical Fiber Communication Conference*. Optical Society of America, 2015, pp. M2A–2.
- [205] X. Liu and F. Effenberger, “Emerging optical access network technologies for 5G wireless,” *Journal of Optical Communications and Networking*, vol. 8, no. 12, pp. B70–B79, 2016.
- [206] M. Al-Hares, P. Assimakopoulos, D. Muench, and N. J. Gomes, “Scheduling in an Ethernet fronthaul network,” in *Proc. IEEE European Conf. on Networks and Communications (EuCNC)*, 2017, pp. 1–5.
- [207] M. K. Al-Hares, P. Assimakopoulos, D. Muench, and N. J. Gomes, “Modeling time aware shaping in an Ethernet fronthaul,” in *Proc. IEEE GLOBECOM*, 2017, pp. 1–6.
- [208] P. Assimakopoulos, M. K. Al-Hares, and N. J. Gomes, “Switched Ethernet fronthaul architecture for cloud-radio access networks,” *IEEE/OSA Journal of Optical Communications and Networking*, vol. 8, no. 12, pp. B135–B146, Dec. 2016.
- [209] P. Assimakopoulos, G. S. Birring, M. K. Al-Hares, and N. J. Gomes, “Ethernet-based fronthauling for cloud-radio access networks,” in *Proc. IEEE Int. Conf. on Transparent Optical Networks (ICTON)*, 2017, pp. 1–4.
- [210] F. Aurzada, M. Scheutzw, M. Reisslein, N. Ghazisaidi, and M. Maier, “Capacity and delay analysis of next-generation passive optical networks (NG-PONs),” *IEEE Transactions on Communications*, vol. 59, no. 5, pp. 1378–1388, 2011.
- [211] N. Carapellese, A. Pizzinat, M. Tornatore, P. Chanclou, and S. Gosselin, “An energy consumption comparison of different mobile backhaul and fronthaul optical access architectures,” in *Optical Communication (ECOC), 2014 European Conference on*. IEEE, 2014, pp. 1–3.
- [212] Z. Tan, C. Yang, and Z. Wang, “Energy consume analysis for ring-topology TWDM-PON front-haul enabled cloud RAN,” *Journal of Lightwave Technology*, vol. 35, no. 20, pp. 4526–4534, 2017.
- [213] J. Wu, S. Guo, H. Huang, W. Liu, and Y. Xiang, “Information and communications technologies for sustainable development goals: State-of-the-art, needs and perspectives,” *IEEE Communications Surveys & Tutorials*, in print, vol. PP, no. 99, pp. 1–1, 2018.
- [214] X. Liu, F. Effenberger, N. Chand, L. Zhou, and H. Lin, “Demonstration of bandwidth-efficient mobile fronthaul enabling seamless aggregation

- of 36 E-UTRA-like wireless signals in a single 1.1-GHz wavelength channel," in *Optical Fiber Communications Conference and Exhibition (OFC)*, 2015. IEEE, 2015, pp. 1–3.
- [215] K.-G. Nguyen, Q.-D. Vu, M. Juntti, and L.-N. Tran, "Energy efficient precoding C-RAN downlink with compression at fronthaul," *arXiv preprint arXiv:1703.05996*, 2017.
- [216] A. Thyagaturu, Z. Alharbi, and M. Reisslein, "R-FFT: Function split at ifft/fft in unified LTE CRAN and cable access network," *IEEE Transactions on Broadcasting*, in print, 2018.
- [217] N. J. Gomes, P. Chanclou, P. Turnbull, A. Magee, and V. Jungnickel, "Fronthaul evolution: from CPRI to ethernet," *Optical Fiber Technology*, vol. 26, pp. 50–58, 2015.
- [218] M. Mao, R. Giddings, B. Cao, Y. Xu, M. Wang, and J. Tang, "DSP-enabled reconfigurable and transparent spectral converters for converging optical and mobile fronthaul/backhaul networks," *Optics Express*, vol. 25, no. 12, pp. 13 836–13 856, 2017.
- [219] N. Cvijetic, A. Tanaka, K. Kanonakis, and T. Wang, "SDN-controlled topology-reconfigurable optical mobile fronthaul architecture for bidirectional CoMP and low latency inter-cell D2D in the 5G mobile era," *Optics express*, vol. 22, no. 17, pp. 20 809–20 815, 2014.
- [220] R. Li, R. Wang, N. Halachmi, Q. Zhong, W. Cheng, L. Wang, and J. Wang, "X-ethernet: Enabling integrated fronthaul/backhaul architecture in 5G networks," in *Proc. IEEE Int. Conf. Standards for Communications and Networking*. IEEE, 2017, pp. 121–125.
- [221] IETF, "Flexible ethernet (FlexE) deep dive - IETF datatracker." [Online]. Available: <https://datatracker.ietf.org/meeting/98/materials/slides-98-ccamp-102-flexe-technology-deep-dive/>
- [222] K. Nichols, V. Jacobson, A. McGregor, and J. Iyengar, "Controlled delay active queue management," 2018.
- [223] D. Xu, Y. Li, X. Chen, J. Li, P. Hui, S. Chen, and J. Crowcroft, "A survey of opportunistic offloading," *IEEE Communications Surveys & Tutorials*, in print, vol. PP, no. 99, pp. 1–1, 2018.
- [224] P.-H. Kuo and A. Mourad, "Millimeter wave for 5G mobile fronthaul and backhaul," in *Proc. IEEE European Conf. on Networks and Communications*, 2017, pp. 1–5.
- [225] V. Jungnickel, D. Schulz, J. Hilt, C. Alexakis, M. Schlosser, L. Grobe, A. Paraskevopoulos, R. Freund, B. Siessegger, and G. Kleinpeter, "Optical wireless communication for backhaul and access," in *Proc. IEEE European Conf. on Optical Communication*. IEEE, 2015, pp. 1–3.
- [226] D. Chitimalla, K. Kondepu, L. Valcarengi, M. Tornatore, and B. Mukherjee, "5G fronthaul-latency and jitter studies of CPRI over ethernet," *IEEE/OSA Journal of Optical Communications and Networking*, vol. 9, no. 2, pp. 172–182, Feb. 2017.
- [227] R. Chundury, "Mobile broadband backhaul: Addressing the challenge," *Planning Backhaul Networks*, *Ericsson Review*, no. 3, pp. 4–9, 2008.
- [228] P. Ameigeiras, J. J. Ramos-Munoz, L. Schumacher, J. Prados-Garzon, J. Navarro-Ortiz, and J. M. Lopez-Soler, "Link-level access cloud architecture design based on SDN for 5G networks," *IEEE Network*, vol. 29, no. 2, pp. 24–31, 2015.
- [229] C. Cox, *An introduction to LTE: LTE, LTE-advanced, SAE and 4G mobile communications*. John Wiley & Sons, 2012.
- [230] J. Chen and J. Li, "Efficient mobile backhaul architecture offering ultra-short latency for handovers," in *Proc. IEEE Int. Conf. Transparent Optical Networks*. IEEE, 2016, pp. 1–1.
- [231] V. Yazıcı, U. C. Kozat, and M. O. Sunay, "A new control plane for 5G network architecture with a case study on unified handoff, mobility, and routing management," *IEEE communications magazine*, vol. 52, no. 11, pp. 76–85, 2014.
- [232] E. Wong, E. Grigoreva, L. Wosinska, and C. M. Machuca, "Enhancing the survivability and power savings of 5G transport networks based on DWDM rings," *IEEE/OSA Journal of Optical Communications and Networking*, vol. 9, no. 9, pp. D74–D85, 2017.
- [233] C.-P. Li, J. Jiang, W. Chen, T. Ji, and J. Smee, "5G ultra-reliable and low-latency systems design," in *Proc. IEEE European Conf. on Networks and Commun.*, 2017, pp. 1–5.
- [234] J. Liu, B. Bai, J. Zhang, and K. B. Letaief, "Cache placement in Fog-RANs: From centralized to distributed algorithms," *IEEE Transactions on Wireless Communications*, vol. 16, no. 11, pp. 7039–7051, Nov. 2017.
- [235] A. Sengupta, R. Tandon, and O. Simeone, "Fog-aided wireless networks for content delivery: Fundamental latency tradeoffs," *IEEE Transactions on Information Theory*, vol. 63, no. 10, pp. 6650–6678, 2017.
- [236] J. Kakar, S. Gherekhloo, Z. H. Awan, and A. Sezgin, "Fundamental limits on latency in cloud-and cache-aided hetnets," in *Proc. IEEE Int. Conf. on Communications*. IEEE, 2017, pp. 1–6.
- [237] A. Radwan, M. F. Domingues, and J. Rodriguez, "Mobile caching-enabled small-cells for delay-tolerant e-health apps," in *Proc. IEEE Int. Conf. on Communications Workshops*. IEEE, 2017, pp. 103–108.
- [238] K. Miyanabe, K. Suto, Z. M. Fadlullah, H. Nishiyama, N. Kato, H. Ujikawa, and K. i. Suzuki, "A cloud radio access network with power over fiber toward 5G networks: QoE-guaranteed design and operation," *IEEE Wireless Communications*, vol. 22, no. 4, pp. 58–64, Aug. 2015.
- [239] M. Olsson, C. Cavdar, P. Frenger, S. Tombaz, D. Sabella, and R. Jantti, "5GrEEn: Towards green 5G mobile networks," in *Wireless and Mobile Computing, Networking and Communications (WiMob)*, 2013 *IEEE 9th International Conference on*. IEEE, 2013, pp. 212–216.
- [240] D. Sabella, A. De Domenico, E. Katranaras, M. A. Imran, M. Di Girolamo, U. Salim, M. Lalam, K. Samdanis, and A. Maeder, "Energy efficiency benefits of RAN-as-a-service concept for a cloud-based 5G mobile network infrastructure," *IEEE Access*, vol. 2, pp. 1586–1597, 2014.
- [241] "Data center bridging. at-a-glance," Cisco. [Online]. Available: https://www.cisco.com/c/dam/en/us/solutions/collateral/data-center-virtualization/ieee-802-1-data-center-bridging/at_a_glance_c45-460907.pdf
- [242] "Learn about data center bridging," Juniper. [Online]. Available: https://www.juniper.net/documentation/en_US/learn-about/data-center-bridging.pdf
- [243] "IEEE Standard for Local and metropolitan area networks—Media Access Control (MAC) Bridges and Virtual Bridged Local Area Networks—Amendment 17: Priority-based Flow Control," *IEEE Std 802.1Qbb-2011 (Amendment to IEEE Std 802.1Q-2011 as amended by IEEE Std 802.1Qbe-2011 and IEEE Std 802.1Qbc-2011)*, pp. 1–40, Sept 2011.
- [244] "IEEE Standards for Local and Metropolitan Area Networks: Supplements to Carrier Sense Multiple Access With Collision Detection (CSMA/CD) Access Method and Physical Layer Specifications - Specification for 802.3 Full Duplex Operation and Physical Layer Specification for 100 Mb/s Operation on Two Pairs of Category 3 Or Better Balanced Twisted Pair Cable (100BASE-T2)," *IEEE Std 802.3x-1997 and IEEE Std 802.3y-1997*, pp. 1–324, 1997.
- [245] "IEEE Standard for Local and metropolitan area networks— Virtual Bridged Local Area Networks Amendment 13: Congestion Notification," *IEEE Std 802.1Qau-2010 (Amendment to IEEE Std 802.1Q-2005)*, pp. c1–119, April 2010.
- [246] "IEEE Standard for Local and metropolitan area networks—Media Access Control (MAC) Bridges and Virtual Bridged Local Area Networks—Amendment 18: Enhanced Transmission Selection for Bandwidth Sharing Between Traffic Classes," *IEEE Std 802.1Qaz-2011 (Amendment to IEEE Std 802.1Q-2011 as amended by IEEE Std 802.1Qbe-2011, IEEE Std 802.1Qbc-2011, and IEEE Std 802.1Qbb-2011)*, pp. 1–110, Sept 2011.
- [247] "IEEE Standard for Local and metropolitan area networks— Bridges and Bridged Networks - Amendment 23: Application Virtual Local Area Network (VLAN) Type, Length, Value (TLV)," *IEEE Std 802.1Qcd-2015 (Amendment to IEEE Std 802.1Q-2014)*, pp. 1–108, March 2015.
- [248] "IEEE Standard for Local and metropolitan area networks - Station and Media Access Control Connectivity Discovery," *IEEE Std 802.1AB-2016 (Revision of IEEE Std 802.1AB-2009)*, pp. 1–146, March 2016.
- [249] B. Guan, J. Wu, Y. Wang, and S. U. Khan, "CIVSched: A communication-aware inter-VM scheduling technique for decreased network latency between co-located VMs," *IEEE Transactions on Cloud Computing*, vol. 2, no. 3, pp. 320–332, Jul. 2014.
- [250] X. Cao, I. Popescu, G. Chen, H. Guo, N. Yoshikane, T. Tsuritani, J. Wu, and I. Morita, "Optimal and dynamic virtual datacenter provisioning over metro-embedded datacenters with holistic sdn orchestration," *Optical Switching and Networking*, vol. 24, pp. 1–11, 2017.
- [251] F. Liu, J. Guo, X. Huang, and J. C. S. Lui, "eba: Efficient bandwidth guarantee under traffic variability in datacenters," *IEEE/ACM Transactions on Networking*, vol. 25, no. 1, pp. 506–519, Feb 2017.
- [252] M. Khabbaz, K. Shaban, and C. Assi, "Delay-aware flow scheduling in low latency enterprise datacenter networks: Modeling and performance analysis," *IEEE Transactions on Communications*, vol. 65, no. 5, pp. 2078–2090, May 2017.
- [253] A. G. Kumbhare, Y. Simmhan, M. Frincu, and V. K. Prasanna, "Reactive resource provisioning heuristics for dynamic dataflows on cloud infrastructure," *IEEE Transactions on Cloud Computing*, vol. 3, no. 2, pp. 105–118, Apr. 2015.
- [254] W. Wang, Y. Sun, K. Salamatian, and Z. Li, "Adaptive path isolation for elephant and mice flows by exploiting path diversity in datacenters,"

- IEEE Transactions on Network and Service Management*, vol. 13, no. 1, pp. 5–18, Mar. 2016.
- [255] A. Shpiner and E. Zahavi, “Race cars vs. trailer trucks: Switch buffers sizing vs. latency trade-offs in data center networks,” in *High-Performance Interconnects (HOTI), 2016 IEEE 24th Annual Symposium on*. IEEE, 2016, pp. 53–59.
- [256] K. He, W. Qin, Q. Zhang, W. Wu, J. Yang, T. Pan, C. Hu, J. Zhang, B. Stephens, A. Akella, and Y. Zhang, “Low latency software rate limiters for cloud networks,” in *Proc. ACM Asia-Pacific Workshop on Networking (APNet)*, 2017, pp. 78–84.
- [257] P. Teymoori, D. Hayes, M. Welzl, and S. Gjessing, “Even lower latency, even better fairness: Logistic growth congestion control in datacenters,” in *2016 IEEE 41st Conference on Local Computer Networks (LCN)*, Nov 2016, pp. 10–18.
- [258] S. N. Avci, Z. Li, and F. Liu, “Congestion aware priority flow control in data center networks,” in *Proc. IEEE IFIP Networking Conf. and Workshops*, May 2016, pp. 126–134.
- [259] B. Stephens, A. L. Cox, A. Singla, J. Carter, C. Dixon, and W. Felter, “Practical dcb for improved data center networks,” in *INFOCOM, 2014 Proceedings IEEE*. IEEE, 2014, pp. 1824–1832.
- [260] M. Alizadeh, A. Kabbani, T. Edsall, B. Prabhakar, A. Vahdat, and M. Yasuda, “Less is more: trading a little bandwidth for ultra-low latency in the data center,” in *Proc. USENIX Conf. on Networked Systems Design and Implementation*, 2012, pp. 19–19.
- [261] M. Alizadeh, T. Edsall, S. Dharmapurikar, R. Vaidyanathan, K. Chu, A. Fingerhut, F. Matus, R. Pan, N. Yadav, G. Varghese *et al.*, “Conga: Distributed congestion-aware load balancing for datacenters,” in *ACM SIGCOMM Computer Communication Review*, vol. 44, no. 4. ACM, 2014, pp. 503–514.
- [262] L. Liu, Z. Zhang, and Y. Yang, “Packet scheduling in a low-latency optical interconnect with electronic buffers,” *IEEE/OSA Journal of Lightwave Technology*, vol. 30, no. 12, pp. 1869–1881, Jun. 2012.
- [263] —, “In-order packet scheduling in optical switch with wavelength division multiplexing and electronic buffer,” *IEEE Transactions on Communications*, vol. 62, no. 6, pp. 1983–1994, Jun. 2014.
- [264] S. Liu, Q. Cheng, M. R. Madarbox, A. Wonfor, R. V. Penty, I. H. White, and P. M. Watts, “Low latency optical switch for high performance computing with minimized processor energy load [invited],” *IEEE/OSA Journal of Optical Communications and Networking*, vol. 7, no. 3, pp. A498–A510, Mar. 2015.
- [265] W. Miao, S. Di Lucente, J. Luo, H. Dorren, and N. Calabretta, “Low latency and efficient optical flow control for intra data center networks,” *Optics express*, vol. 22, no. 1, pp. 427–434, 2014.
- [266] W. Miao, F. Yan, and N. Calabretta, “Towards petabit/s all-optical flat data center networks based on wdm optical cross-connect switches with flow control,” *Journal of Lightwave Technology*, vol. 34, no. 17, pp. 4066–4075, Sept 2016.
- [267] L. Wang, X. Wang, M. Tornatore, K. joon Kim, S. M. Kim, D.-U. Kim, K.-E. Han, and B. Mukherjee, “Priority-aware scheduling for packet-switched optical networks in datacenter,” in *2017 International Conference on Optical Network Design and Modeling (ONDM)*, May 2017, pp. 1–5.
- [268] Z. Guo and Y. Yang, “High-speed multicast scheduling in hybrid optical packet switches with guaranteed latency,” *IEEE Transactions on Computers*, vol. 62, no. 10, pp. 1972–1987, Oct. 2013.
- [269] —, “Low-latency multicast scheduling in all-optical interconnects,” *IEEE Transactions on Communications*, vol. 62, no. 4, pp. 1310–1323, Apr. 2014.
- [270] J. Perello, S. Spadaro, S. Ricciardi, D. Careglio, S. Peng, R. Nejabati, G. Zervas, D. Simeonidou, A. Predieri, M. Biancani, H. J. S. Dorren, S. D. Lucente, J. Luo, N. Calabretta, G. Bernini, N. Ciulli, J. C. Sancho, S. Iordache, M. Farreras, Y. Becerra, C. Liou, I. Hussain, Y. Yin, L. Liu, and R. Proietti, “All-optical packet/circuit switching-based data center network for enhanced scalability, latency, and throughput,” *IEEE Network*, vol. 27, no. 6, pp. 14–22, Nov. 2013.
- [271] F. Yan, W. Miao, H. Dorren, and N. Calabretta, “On the cost, latency, and bandwidth of lightness data center network architecture,” in *2015 International Conference on Photonics in Switching (PS)*, Sept 2015, pp. 130–132.
- [272] G. Saridis, S. Peng, Y. Yan, A. Aguado, B. Guo, M. Arslan, C. Jackson, W. Miao, N. Calabretta, F. Agraz *et al.*, “Lightness: A deeply-programmable sdn-enabled data centre network with ocs/ops multicast/unicast switch-over,” in *Optical Communication (ECOC), 2015 European Conference on*. IEEE, 2015, pp. 1–3.
- [273] G. M. Saridis, S. Peng, Y. Yan, A. Aguado, B. Guo, M. Arslan, C. Jackson, W. Miao, N. Calabretta, F. Agraz *et al.*, “Lightness: A function-virtualizable software defined data center network with all-optical circuit/packet switching,” *Journal of Lightwave Technology*, vol. 34, no. 7, pp. 1618–1627, 2016.
- [274] W. Miao, F. Agraz, S. Peng, S. Spadaro, G. Bernini, J. Perello, G. Zervas, R. Nejabati, N. Ciulli, D. Simeonidou *et al.*, “Sdn-enabled ops with qos guarantee for reconfigurable virtual data center networks,” *Journal of Optical Communications and Networking*, vol. 7, no. 7, pp. 634–643, 2015.
- [275] A. Pagès, M. P. Sanchís, S. Peng, J. Perello, D. Simeonidou, and S. Spadaro, “Optimal virtual slice composition toward multi-tenancy over hybrid ocs/ops data center networks,” *Journal of Optical Communications and Networking*, vol. 7, no. 10, pp. 974–986, 2015.
- [276] Y. Gong, Y. Lu, X. Hong, S. He, and J. Chen, “Passive optical interconnects at top of the rack for data center networks,” in *Optical Network Design and Modeling, 2014 International Conference on*. IEEE, 2014, pp. 78–83.
- [277] T. Berisa and M. Maier, “Low-latency polling for passive optical networks,” *IEEE Communications Letters*, vol. 17, no. 6, pp. 1288–1291, Jun. 2013.
- [278] E. Wong, M. P. I. Dias, and L. Ruan, “Predictive resource allocation for tactile internet capable passive optical LANs,” *IEEE/OSA Journal of Lightwave Technology*, vol. 35, no. 13, pp. 2629–2641, Jul. 2017.
- [279] M. C. Yuang, P. L. Tien, H. Y. Chen, W. Z. Ruan, T. K. Hsu, S. Zhong, J. Zhu, Y. Chen, and J. Chen, “OPMDC: Architecture design and implementation of a new optical pyramid data center network,” *IEEE/OSA Journal of Lightwave Technology*, vol. 33, no. 10, pp. 2019–2031, May 2015.
- [280] Y. Liu, D. Niu, and B. Li, “Delay-optimized video traffic routing in software-defined interdatacenter networks,” *IEEE Transactions on Multimedia*, vol. 18, no. 5, pp. 865–878, May 2016.
- [281] I. Fujiwara, M. Koibuchi, H. Matsutani, and H. Casanova, “Swap-and-randomize: A method for building low-latency hpc interconnects,” *IEEE Transactions on Parallel and Distributed Systems*, vol. 26, no. 7, pp. 2051–2060, July 2015.
- [282] V. Persico, A. Botta, P. Marchetta, A. Montieri, and A. Pescapé, “On the performance of the wide-area networks interconnecting public-cloud datacenters around the globe,” *Computer Networks*, vol. 112, pp. 67–83, 2017.
- [283] T. Zhang, J. Wang, J. Huang, Y. Huang, J. Chen, and Y. Pan, “Adaptive marking threshold method for delay-sensitive tcp in data center network,” *Journal of Network and Computer Applications*, vol. 61, pp. 222–234, 2016.
- [284] M. Patel and A. Pandya, “Edge computing: Design a framework for monitoring performance between datacenters and devices of edge networks,” 2017.
- [285] Q. Pu, G. Ananthanarayanan, P. Bodik, S. Kandula, A. Akella, P. Bahl, and I. Stoica, “Low latency geo-distributed data analytics,” in *ACM SIGCOMM Computer Communication Review*, vol. 45, no. 4. ACM, 2015, pp. 421–434.
- [286] J. W. Lockwood and M. Monga, “Implementing ultra low latency data center services with programmable logic,” in *Proc. IEEE Symp. High-Performance Interconnects*, 2015, pp. 68–77.
- [287] S. H. S. Rezaei, A. Mazloumi, M. Modarressi, and P. Lotfi-Kamran, “Dynamic resource sharing for high-performance 3-D networks-on-chip,” *IEEE Computer Architecture Letters*, vol. 15, no. 1, pp. 5–8, Jan. 2016.
- [288] A. Hammadi and L. Mhamdi, “A survey on architectures and energy efficiency in data center networks,” *Computer Communications*, vol. 40, pp. 1–21, 2014.
- [289] J. Shuja, K. Bilal, S. A. Madani, M. Othman, R. Ranjan, P. Balaji, and S. U. Khan, “Survey of techniques and architectures for designing energy-efficient data centers,” *IEEE Systems Journal*, vol. 10, no. 2, pp. 507–519, 2016.
- [290] K. Bilal, S. U. R. Malik, O. Khalid, A. Hameed, E. Alvarez, V. Wijaysekara, R. Irfan, S. Shrestha, D. Dwivedy, M. Ali *et al.*, “A taxonomy and survey on green data center networks,” *Future Generation Computer Systems*, vol. 36, pp. 189–208, 2014.
- [291] F. Jalali, S. Khodadustan, C. Gray, K. Hinton, and F. Suits, “Greening iot with fog: A survey,” in *Edge Computing (EDGE), 2017 IEEE International Conference on*. IEEE, 2017, pp. 25–31.
- [292] F. P. Tso, S. Jouet, and D. P. Pazaros, “Network and server resource management strategies for data center infrastructures: A survey,” *Computer Networks*, vol. 106, pp. 209–225, 2016.
- [293] X. Jin, F. Zhang, A. V. Vasilakos, and Z. Liu, “Green data centers: A survey, perspectives, and future directions,” *arXiv preprint arXiv:1608.00687*, 2016.

- [294] C. Kachris and I. Tomkos, "A survey on optical interconnects for data centers," *IEEE Communications Surveys Tutorials*, vol. 14, no. 4, pp. 1021–1036, Fourth 2012.
- [295] G. C. Sankaran and K. M. Sivalingam, "A survey of hybrid optical data center network architectures," *Photonic Network Communications*, vol. 33, no. 2, pp. 87–101, 2017.
- [296] B. Wang, Z. Qi, R. Ma, H. Guan, and A. V. Vasilakos, "A survey on data center networking for cloud computing," *Computer Networks*, vol. 91, pp. 528–547, 2015.
- [297] M. F. Bari, R. Boutaba, R. Esteves, L. Z. Granville, M. Podlesny, M. G. Rabbani, Q. Zhang, and M. F. Zhani, "Data center network virtualization: A survey," *IEEE Communications Surveys & Tutorials*, vol. 15, no. 2, pp. 909–928, 2013.
- [298] B. Lebednik, A. Mangal, and N. Tiwari, "A survey and evaluation of data center network topologies," *arXiv preprint arXiv:1605.01701*, 2016.
- [299] Z. Á. Mann, "Allocation of virtual machines in cloud data centers: a survey of problem models and optimization algorithms," *Acm Computing Surveys (CSUR)*, vol. 48, no. 1, p. 11, 2015.
- [300] T. Chen, X. Gao, and G. Chen, "The features, hardware, and architectures of data center networks: A survey," *Journal of Parallel and Distributed Computing*, vol. 96, pp. 45–74, 2016.
- [301] Y. Ren, Y. Zhao, P. Liu, K. Dou, and J. Li, "A survey on tcp incast in data center networks," *International Journal of Communication Systems*, vol. 27, no. 8, pp. 1160–1172, 2014.
- [302] P. Sreekumari and J.-i. Jung, "Transport protocols for data center networks: a survey of issues, solutions and challenges," *Photonic Network Communications*, vol. 31, no. 1, pp. 112–128, 2016.
- [303] R. Rojas-Cessa, Y. Kaymak, and Z. Dong, "Schemes for fast transmission of flows in data center networks," *IEEE Communications Surveys & Tutorials*, vol. 17, no. 3, pp. 1391–1422, 2015.
- [304] T. Hafeez, N. Ahmed, B. Ahmed, and A. W. Malik, "Detection and mitigation of congestion in sdn enabled data center networks: A survey," *IEEE Access*, 2017.
- [305] S. Liu, H. Xu, and Z. Cai, "Low latency datacenter networking: A short survey," *arXiv preprint arXiv:1312.3455*, 2013.
- [306] P. Barham, B. Dragovic, K. Fraser, S. Hand, T. Harris, A. Ho, R. Neugebauer, I. Pratt, and A. Warfield, "Xen and the art of virtualization," in *ACM SIGOPS operating systems review*, vol. 37, no. 5. ACM, 2003, pp. 164–177.
- [307] M. Alizadeh, A. Greenberg, D. A. Maltz, J. Padhye, P. Patel, B. Prabhakar, S. Sengupta, and M. Sridharan, "Data center tcp (dctcp)," in *ACM SIGCOMM computer communication review*, vol. 40, no. 4. ACM, 2010, pp. 63–74.
- [308] M. Noormohammadpour and C. S. Raghavendra, "Datacenter traffic control: Understanding techniques and trade-offs," *IEEE Communications Surveys & Tutorials, in print*, vol. PP, no. 99, pp. 1–1, 2018.
- [309] B. Atikoglu, Y. Xu, E. Frachtenberg, S. Jiang, and M. Paleczny, "Workload analysis of a large-scale key-value store," in *ACM SIGMETRICS Performance Evaluation Review*, vol. 40, no. 1. ACM, 2012, pp. 53–64.
- [310] N. Abbas, Y. Zhang, A. Taherkordi, and T. Skeie, "Mobile edge computing: A survey," *IEEE Internet of Things Journal*, vol. 5, no. 1, pp. 450–465, Feb. 2018.
- [311] I. Ahmad, W. Chen, and K. Chang, "LTE-railway user priority-based cooperative resource allocation schemes for coexisting public safety and railway networks," *IEEE Access*, vol. 5, pp. 7985–8000, 2017.
- [312] G. Carvajal, L. Aranedo, A. Wolf, M. Figueroa, and S. Fischmeister, "Integrating dynamic-TDMA communication channels into COTS ethernet networks," *IEEE Transactions on Industrial Informatics*, vol. 12, no. 5, pp. 1806–1816, Oct. 2016.
- [313] W. Chen, S. A. Patel, P. Gaal, H. Xu, and T. Luo, "Techniques for handling channel state information (CSI) in ultra low latency ULL-LTE," Dec. 21 2015, US Patent App. 14/977,163.
- [314] D. Choudhury and T. Inoue, "Guest editorial special issue on 5G wireless communication systems and technologies," *IEEE Transactions on Microwave Theory and Techniques*, vol. 64, no. 7, pp. 2205–2206, Jul. 2016.
- [315] M. Condoluci, T. Mahmoodi, E. Steinbach, and M. Dohler, "Soft resource reservation for low-delayed teleoperation over mobile networks," *IEEE Access*, vol. 5, pp. 10445–10455, 2017.
- [316] G. Durisi, T. Koch, and P. Popovski, "Toward massive, ultrareliable, and low-latency wireless communication with short packets," *Proceedings of the IEEE*, vol. 104, no. 9, pp. 1711–1726, Sep. 2016.
- [317] L. Fan, Z. Dong, and P. Yuan, "The capacity of device-to-device communication underlying cellular networks with relay links," *IEEE Access*, vol. 5, pp. 16840–16846, 2017.
- [318] B. Lee, S. Park, D. J. Love, H. Ji, and B. Shim, "Packet structure and receiver design for low latency wireless communications with ultra-short packets," *IEEE Transactions on Communications*, vol. 66, no. 2, pp. 796–807, Feb. 2018.
- [319] F. Lu, L. Cheng, M. Xu, J. Wang, S. Shen, and G. K. Chang, "Orthogonal and sparse chirp division multiplexing for MMW fiber-wireless integrated systems," *IEEE Photonics Technology Letters*, vol. 29, no. 16, pp. 1316–1319, Aug. 2017.
- [320] S. A. Patel, W. Chen, A. Damnjanovic, P. Gaal, M. S. Vajapeyam, and H. Xu, "Traffic data allocations in low latency LTE downlink communications," Oct. 28 2015, US Patent App. 14/925,501.
- [321] J. Pilz, M. Mehlhose, T. Wirth, D. Wieruch, B. Holfeld, and T. Haustein, "A tactile internet demonstration: 1 ms ultra low delay for wireless communications towards 5G," in *Proc. IEEE INFOCOM Wkshps*, 2016, pp. 862–863.
- [322] B. P. Rimal, D. P. Van, and M. Maier, "Mobile edge computing empowered fiber-wireless access networks in the 5G era," *IEEE Communications Magazine*, vol. 55, no. 2, pp. 192–200, Feb. 2017.
- [323] M. Salem, A. Adinoyi, H. Yanikomeroglu, and D. Falconer, "Fair resource allocation toward ubiquitous coverage in OFDMA-based cellular relay networks with asymmetric traffic," *IEEE Transactions on Vehicular Technology*, vol. 60, no. 5, pp. 2280–2292, Jun. 2011.
- [324] T. K. Vu, C. F. Liu, M. Bennis, M. Debbah, M. Latva-aho, and C. S. Hong, "Ultra-reliable and low latency communication in mmWave-enabled massive MIMO networks," *IEEE Communications Letters*, vol. 21, no. 9, pp. 2041–2044, Sep. 2017.
- [325] J. Y. Wei and R. I. McFarland, "Just-in-time signaling for WDM optical burst switching networks," *IEEE/OSA Journal of Lightwave Technology*, vol. 18, no. 12, pp. 2019–2037, Dec. 2000.
- [326] J. Wu, C. Yuen, N. M. Cheung, J. Chen, and C. W. Chen, "Enabling adaptive high-frame-rate video streaming in mobile cloud gaming applications," *IEEE Transactions on Circuits and Systems for Video Technology*, vol. 25, no. 12, pp. 1988–2001, Dec. 2015.
- [327] J. Zhang, Y. Ji, S. Jia, H. Li, X. Yu, and X. Wang, "Reconfigurable optical mobile fronthaul networks for coordinated multipoint transmission and reception in 5G," *IEEE/OSA Journal of Optical Communications and Networking*, vol. 9, no. 6, pp. 489–497, Jun. 2017.
- [328] A. Blenk, A. Basta, M. Reisslein, and W. Kellerer, "Survey on network virtualization hypervisors for software defined networking," *IEEE Communications Surveys & Tutorials*, vol. 18, no. 1, pp. 655–685, First Qu. 2016.
- [329] M. Caporuscio, P.-G. Raverdy, H. Mounghla, and V. Issarny, "ubiSOAP: A service oriented middleware for seamless networking," in *Proc. Int. Conf. on Service-Oriented Computing, LNCS 5364*. Springer, Berlin, Heidelberg, 2008, pp. 195–209.