

vLibOS: Babysitting OS Evolution with a Virtualized Library OS

Ying Ye, Zhuoqun Cheng, Soham Sinha, Richard West
Computer Science Department
Boston University
Email: {yingy,czq,soham1,richwest}@cs.bu.edu

Abstract

Many applications have service requirements that are not easily met by existing operating systems. Real-time and security-critical tasks, for example, often require custom OSes to meet their needs. However, development of special purpose OSes is a time-consuming and difficult exercise. Drivers, libraries and applications have to be written from scratch or ported from existing sources. Many researchers have tackled this problem by developing ways to extend existing systems with application-specific services. However, it is often difficult to ensure an adequate degree of separation between legacy and new services, especially when security and timing requirements are at stake. Virtualization, for example, supports logical isolation of separate guest services, but suffers from inadequate temporal isolation of time-critical code required for real-time systems. This paper presents vLibOS, a master-slave paradigm for new systems, whose services are built on legacy code that is temporally and spatially isolated in separate VM domains. Existing OSes are treated as sandboxed libraries, providing legacy services that are requested by inter-VM calls, which execute with the time budget of the caller. We evaluate a real-time implementation of vLibOS. Empirical results show that vLibOS achieves as much as a 50% reduction in performance slowdown for real-time threads, when competing for a shared memory bus with a Linux VM.

1. Introduction

Computer hardware is evolving rapidly today, with computing devices now supporting multiple cores, virtualiza-

tion, and general purpose graphics processing units (GPGPUs). Modern hardware capabilities have led to the emergence of new classes of applications requiring safety, security and timing predictability. For example, driverless cars, unmanned aerial vehicles, smart manufacturing devices and other Internet-of-Things (IoT) applications require data to be exchanged and processed both securely and predictably, and decisions to be made in real-time. However, existing general-purpose OSes (GPOS) are ill-equipped to address the needs of these emerging applications; many existing systems are not easily extensible due to their monolithic design that does not securely or safely isolate new features. Similarly, general-purpose systems focus on fair resource management for multiple users, rather than timing guarantees required of certain mission-critical applications. This means developers are either required to apply ad hoc patches to existing systems, or they must write operating systems from scratch for their specific application needs. Patching existing systems does not easily achieve the desired end goals because of the fundamental mismatch between a GPOS' design goals and custom applications' requirements. Alternatively, writing a new OS is a time-consuming and difficult exercise. Device drivers, libraries and application-programming interfaces must all be written for a new OS to support any kind of non-trivial application.

Traditional wisdom [12] argues that a modular design makes kernel writing easier. Common features are made available for reuse as kernel modules, as long as module interfaces are well-defined. Legacy device drivers can be ported to a new kernel by encapsulating them within adaptation layers. However, strict modularization tends to involve performance tradeoffs and creating adaptation layers is often a difficult task.

Using virtualization extensions found on many of today's multicore processors, it is possible to treat existing systems as guest services in the development of new OS functionality. A new OS implemented in one guest domain leverages legacy OS features in another guest domain, without requiring a clean-slate implementation of everything. A vir-

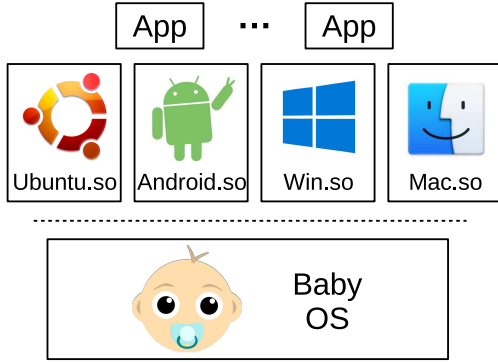

Figure 1. vLibOS Concept

tual machine (VM) provides a sandbox for OS developers to implement innovative new mechanisms, while delegating certain services to legacy OSes [2]. However, VMs running on the same processor compete for shared hardware resources such as the last-level cache (LLC) and the memory bus [43, 44]. Without careful management of VM execution, system performance is arbitrarily impacted.

We attribute the interference issue to the lack of a global resource manager. In a virtualized environment, the hypervisor assumes the role of a shared resource manager. Nevertheless, we have discovered several issues with this approach, which will be discussed in Section 2. In this paper, we argue the case for a newly-developed *baby OS* to act as a global resource manager for OS services spanning multiple VMs. This way, the baby OS in one VM is able to control the resource usage of legacy OSes in other VMs, ensuring the desired behavior of the overall system. For example, by regulating DRAM traffic from each core and reducing bus contention, the Quality-of-Service (QoS) for timing-sensitive applications is greatly improved [46]. In general, Denial-of-Service (DoS) attacks on shared resources [22] from a compromised legacy OS VM are preventable.

In this paper, we describe a novel system architecture (Figure 1) for building QoS-aware OSes. The master-slave paradigm is adopted, in which the baby OS is the master and legacy OSes act as slaves. With the assistance of hardware virtualization, slaves are controlled by the master, to provide legacy services, including libraries, device drivers, and system calls. We call each slave a virtualized library OS, or *vLib OS*. A vLib OS is not a traditional library OS. Traditional library OS models focus on re-writing OS services as application components, often requiring significant engineering effort. On the contrary, our vLibOS model helps the construction and adoption of new OSes by relying on legacy OSes to provide a feature-rich environment with minimum effort. Moreover, unlike traditional library OS designs that treat an OS as a set of application libraries, we view an entire legacy OS as a single library to be added to the master. Thus, a vLib OS acts as a standard library whose execution is under the control of the master. With this extended con-

trol, the master is able to manage global hardware resources, providing enhanced QoS.

The contributions of this work are threefold:

- We propose the vLibOS model for building new OSes, with legacy support fulfilled by existing OSes. We argue that shared hardware resources should be managed by the baby OS instead of the hypervisor.
- We introduce an implementation of vLibOS to ease the development of a feature-rich real-time system.
- We also discuss the application of the vLibOS model and its alternative implementations in different settings.

The rest of this paper is organized as follows: The next section describes motivation and challenges for the use of virtualization in OS evolution. Section 3 discusses the vLibOS model and its general design principles. A real-time system implementation of vLibOS is then shown in Section 4, along with a discussion of the pros and cons. Section 5 describes an evaluation of our real-time system and how it meets predictable execution requirements. This is followed by a description of related work in Section 6. Finally, conclusions and future work are outlined in Section 7.

2. Motivation

Operating systems have been evolving for decades, in response to hardware advances and new applications. The addition of new mechanisms and policies oftentimes demands a substantial restructuring to the system. For example, replacing the O(1) scheduler in Linux with the Completely Fair Scheduler (CFS) required an entire overhaul of the scheduling infrastructure [15]. In other cases, it is almost impossible to extend the functionality of an existing system without completely rewriting fundamental components. For example, adding real-time guarantees to a previously non-real-time OS, improving scalability beyond a previous system limit, or heightening system security. Under these situations, a new kernel [4, 11, 18] needs to be developed.

One of the biggest stumbling blocks in the construction and adoption of a new OS is the support for legacy applications, libraries and device drivers. Millions of applications are immediately available on existing OSes while thousands more are being developed every day. Similarly, third parties regularly contribute libraries and device drivers to pre-existing systems such as Windows and Linux. In contrast, a new OS might only support a few features, and the effort required to port the rest is potentially many man-years.

Virtualization provides an opportunity to combine legacy system features with new OS abstractions, greatly saving engineering cost. It is possible to encapsulate full-blown OSes in separate virtual machines, and have their services made accessible to another OS using an appropriately implemented Remote Procedure Call (RPC) mechanism.

Consider, for example, the development of a mixed-criticality system [42], combining components with different timing, safety and security criticality levels [35]. Here, crit-

icality is defined in terms of the consequences of a system or component failure. Such a system might be applicable in the automotive domain, where the services for chassis (e.g., braking and stability control), body (e.g., lighting and climate control), and information (e.g., infotainment and navigation) are consolidated onto a single multicore platform. Such a system might employ a legacy Android system to support low-criticality infotainment and navigation services, while implementing high-criticality services like managing vehicle stability and braking as part of a new AUTOSAR-compliant [3] OS. The high-criticality services require temporal and spatial isolation from legacy code to ensure their correct timing behavior. Moreover, the failure of a low-criticality service should not compromise the behavior of one with higher criticality.

While virtualization provides a way to integrate legacy functionality into a new OS, it does not solve the problem of performance isolation. Virtualization has traditionally only provided a logical separation between guest virtual machines. However, when multiple VMs execute on separate cores, they compete for shared last-level caches, memory buses and DRAM [44, 45]. Uncontrolled access to shared physical resources leads to detrimental performance interference. Newly-developed timing-sensitive services are in jeopardy of unbounded timing delays from the execution of other VM-based services.

It is possible to modify a hypervisor in existing virtualization systems such as Xen or VMware ESXi to ensure performance isolation. This requires the implementation of timing-aware resource management policies. However, there are several issues with this approach. First, since every guest OS already has its own mechanisms and policies for managing shared resources, adding OS-specific policies to a hypervisor not only creates unwanted inter-dependencies but also duplicates functionality. Modifications to a guest OS may require alterations to the underlying virtualization infrastructure as well. Second, adding resource management policies to the hypervisor increases the size of the Trusted Computing Base (TCB), potentially reducing the security and reliability of the entire system [38]. Third, hypervisors perform resource accounting at the granularity of virtual CPUs, which adds overhead to the accounting mechanisms already in the guest OS. For instance, suppose a QoS-aware guest OS tries to improve worst case DRAM access latency, by tracking every threads DRAM access rate and performing traffic regulation when the memory bus is heavily contended [46]; to avoid inter-VM interference and meet the required QoS, the hypervisor also needs to manage the DRAM access of every VM, introducing an extra layer of resource accounting on the bus. Fourth, applications that request services from other guest OSes, henceforth referred to as *dual-mode* applications, require resource accounting (e.g., CPU budget, cache occupancy, memory bandwidth) to span multiple VMs. Current hypervisors only account for resource usage by individ-

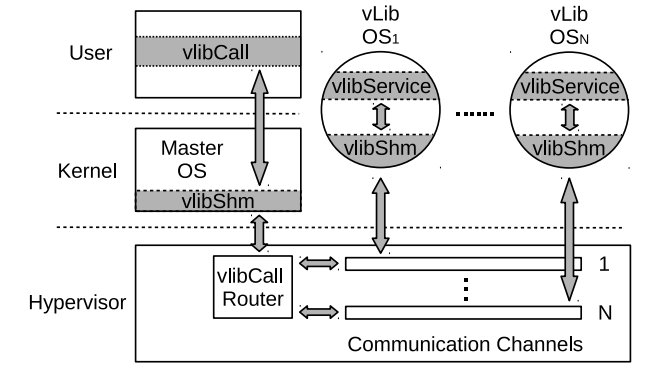

Figure 2. vLibOS Architecture

ual VMs. Without accurately accounting resource usage for dual-mode (inter-VM) applications, resource management cannot be carried out effectively.

With the above considerations in mind, we believe it is still possible to use virtualization for running legacy services in conjunction with newly-defined OS functionality. However, for virtualization to be effectively used in the construction of evolvable and QoS-aware systems, it is important to provide performance isolation and proper resource accounting across multiple VMs. This requires new hypervisor technologies that will be described in the next section.

3. vLibOS Design

The architecture of vLibOS is shown in Figure 2. It consists of a set of user APIs, a master OS, a set of vLib OSes, and a hypervisor. The master OS implements new features while leveraging pre-existing services in one or more vLib OSes. Each vLib OS runs under the control of the master.

3.1 User APIs

Each vLib OS runs a server program to provide services to the master. A call to

```
channelAddr*vLib_Listen(port)
```

from the *vlibService* library blocks the entire vLib OS until it is requested to execute on behalf of a service caller. This causes all virtual CPUs to be suspended inside the hypervisor, waiting for vLib calls from client threads inside the master OS. A port number is used to uniquely identify vLib OSes. Once this function is unblocked, it returns a virtual address to the communication channel established between the client and itself, which contains all the data needed for the service. The data includes the function requested, the name of the library that contains the function, and the input data. Service completion causes the server to write the output back to the channel, followed by calling *vLib_Listen* again. This leads to a completion signal being sent to the client, and the vLib OS waits for another request. An example vLib server is listed below (Listing 1).

Listing 1. Example vLib Server

```

while ( channel = vLib_listen(port) ) {
    /* locate service */
    /* unmarshal data */
    /* perform service */
    /* write result back to channel */
}

```

A client application uses the *vlibCall* library to make vLib calls into services from one of the vLib OSes. The following APIs are provided:

- *errCode vLib_init(port, channel_size, **channel_addr);*
- *errCode vLib_call(port, timeout);*
- *errCode vLib_async_call(port, callback, timeout);*
- *errCode vLib_channel_destroy(port);*

vLib_init establishes a communication channel to the vLib OS listening on *port*. After data is copied into the channel, a subsequent *vLib_call* requests a service with an optional *timeout* for the server-side processing. Multiple service requests to a single vLib OS are serialized in FIFO order. The timeout is used to terminate the service wait, which guarantees a bounded delay for the call and avoids liability inversion [14]. A *vLib_call* is a blocking (i.e., synchronous) request, while a *vLib_async_call* provides a non-blocking asynchronous interface. An existing channel is closed and its resources are reclaimed through *vLib_channel_destroy*.

3.2 Master OS

A vLibOS system includes a single master OS, which acts as a centralized manager of all hardware resources with the help of a hypervisor. Both native applications and *dual-mode* applications (spanning the master and one or more vLib OSes) are supported. Dual-mode applications start in the master, for proper cross-VM resource accounting. A *vlibShm* kernel module maps communication channels into applications' address spaces.

3.3 vLib OS

A vLib OS is any existing OS, such as a UNIX-based system with process address spaces, or a traditional library OS having a single address space [21]. Each vLib OS provides functionality for use by the master OS. The hardware Performance Monitoring Unit (PMU) is virtualized to a vLib OS. Core-local performance counters will not be exposed if being used by the hypervisor/master. Also, global performance events are made inaccessible. This hardens security isolation between the master and vLib OSes. For example, information leakage from side channels based on PMU data is avoided [16]. The separation of a master OS and one or more vLib OSes provides the basis for a mixed-criticality system. Each vLib OS establishes a sandbox domain for services of different timing, safety and security criticalities. As with the master OS, each vLib OS uses a *vlibShm* module to map communication channels into the server's address space.

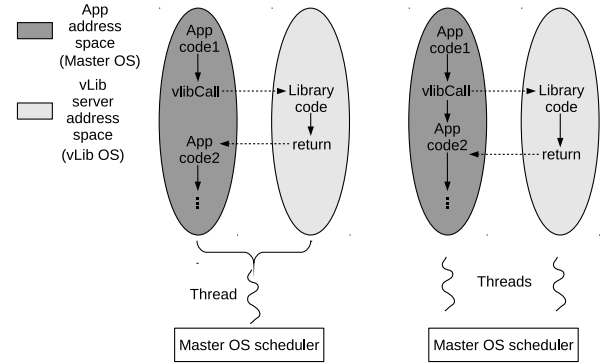

Figure 3. vLibOS Unified Scheduling (left is sync call, right is async call)

3.4 Hypervisor

The hypervisor in vLibOS is responsible for booting OSes and delegating resources (CPUs, memory and devices) to them. It provides an interface to VMs to support the user APIs from Section 3.1. For vLib calls, it allocates communication channels between client applications and servers upon request, and routes calls to the right destinations (using the vLibCall Router in Figure 2). To avoid time-related issues inside a vLib OS due to blocking, guest time is virtualized. More importantly, the hypervisor empowers a master OS with the capability to block and wake up other VMs. This means the execution of a vLib OS is integrated into the scheduling framework of the master, for effective hardware resource management.

Figure 3 illustrates the unified scheduling mechanism in vLibOS. A vLib call resembles an RPC, with the caller and callee occupying separate address spaces. However, for synchronous vLib calls, the callee shares the same resource accounting entity (thread from the master OS) with the caller. The callee in a vLib OS executes with the CPU budget of the calling thread from the master. Once the budget is depleted, or preemption occurs in the master, the callee is descheduled. For asynchronous vLib calls, the master OS manages the callee as a second thread. This mechanism extends the capability of a resource-aware scheduler in the master OS, for managing resource contention across the entire platform.

3.5 Applications

Applications can utilize vLib OS services in several ways. In the first case, dual-mode applications start in the master and send each request through a vLib call. As a vLib call incurs higher overhead than a library call, this approach should be avoided on performance critical paths. In the second case, a dual-mode application first makes an async vLib call (with no input) to pass its CPU budget to a vLib OS. Then it writes a series of service requests to the communication channel. The server on the other side, upon returning from *vLib_listen()*, starts polling on the communication channel to get the actual requests. When an ending signal is

received, the server jumps back to *vLib_Listen()*, indicating the end of this async vLib call session. This approach, while greatly reducing system overhead for sending each request, locks a vLib OS for a longer period as well, thus blocking other applications from requesting services. In the third case, applications run entirely inside a vLib OS, while a dummy thread is created in the master. The dummy thread makes a single sync vLib call with no input. After receiving the call, the server terminates without signaling service completion. Consequently, all other applications on the vLib OS inherit the dummy thread’s CPU budget and continue execution.

4. Implementation: A Multicore Real-Time System

We implemented our vLibOS architecture by extending an existing virtualization system, referred to as Quest-V [17]. Quest-V is targeted at secure and predictable embedded systems, where virtualization is used to isolate legacy functionality from timing, safety and security-critical custom OS features. The system currently runs on the x86 (IA32) architecture with VT-x virtualization extensions. It provides separate VM domains for a master OS and a Linux vLib OS. Our master OS, Quest [44], is a real-time operating system (RTOS) designed from scratch.

4.1 Partitioning Hypervisor

Our hypervisor relies on hardware-assisted virtualization to achieve efficient resource partitioning. CPU cores, memory and I/O devices are statically partitioned during system boot time, which means there is no resource multiplexing. Each VM is only allowed to access the physical resources within its domain.

Unified Scheduling. Although hardware resources are partitioned, the hypervisor still allows the master OS to indirectly control the resource usage of vLib OSes. This is achieved by extending the original hypervisor with our unified scheduling mechanism, which requires coordination between the master OS, the vLib server and the hypervisor.

Firstly, when the vLib server invokes *vLib_Listen*, it jumps into the hypervisor and blocks the entire VM waiting for vLib calls. Later, a client thread in the master makes a vLib call into the kernel, which then transfers control to the hypervisor. A request flag is set to unblock the destination vLib OS, while input data is passed to it through a pre-created communication channel. After unblocking, the CPU running the client returns to the master OS kernel space. Instead of blocking the user thread, the kernel marks it as being in a *remote state* and forces it to busy wait on the channel for a request completion signal, with interrupt and kernel pre-emption enabled. This effectively turns the thread into an idle thread. From the perspective of the client, the vLib call is a blocking call. However, inside the busy waiting loop, timestamps are checked to enforce the vLib call timeout. Notice that this busy waiting approach greatly simplifies the

changes that need to be made to the master OS scheduler, though it leads to a lowered CPU utilization (which can be avoided, see Section 4.4).

On the server side, the vLib OS is unblocked and the channel ID is passed to the vLib server. If the channel has not been mapped before, the server passes control into the *vlibShm* kernel module (details in Section 4.3). This module maps the specified communication channel into the server’s address space. After the channel is mapped, the server commences request handling.

If the waiting client thread runs out of CPU budget, it is descheduled. Meanwhile, the scheduler generates an Inter-Processor Interrupt (IPI) to the vLib OS CPU(s). Although normal interrupts are directly delivered to guest OSes to reduce virtualization overhead, Non-Maskable Interrupts (NMIs) are configured to cause VM exits. By setting the delivery mode of an IPI to be NMI, the destination core’s control is passed into the hypervisor (similar to how Jailhouse behaves [32]). The hypervisor performs resource accounting (including cache occupancy and memory bandwidth usage) for the VM which is then blocked. We call this process *remote descheduling*. All resource usage data is returned to the master OS and budgeted to the client thread. When the client thread is dispatched again, an unblock signal is set so that the vLib OS resumes its execution from where it was previously descheduled. In the scheduler’s view, the client thread is executing the vLib OS service the entire time. Hence, the execution of client threads and services are unified.

After the server completes a service, it calls *vLib_Listen* again. Before waiting for another request, it sets a completion signal. This allows the client thread to exit its idle loop, discard its remote state and return to user space with the service result. Note that in this paper, we focus only on synchronous vLib calls. We will discuss the issue of asynchronous vLib calls in Section 4.4.

4.2 Real-Time Master OS

Mostly, we take Quest as it is except a scheduler extension for remote state handling and a kernel module (*vlibShm*) for channel mapping. Quest features a multicore real-time scheduling framework, which combines partitioned scheduling with dynamic load balancing. Central to the scheduling framework is the management of virtual CPUs (VCPUs)¹.

VCPU. VCPUs are created in Quest to serve as resource containers for corresponding threads. A VCPU accounts for budgeted CPU time usage for specific threads and serves as an entity against which scheduling decisions are made. Each VCPU, V_i , is specified a CPU budget, C_i , and a period, T_i . The system guarantees that a VCPU receives at least its budget in every period when it is runnable, given the total CPU utilization, $U = \sum_{i=1}^n \frac{C_i}{T_i}$ for n VCPUs, is less than a specific threshold. In this paper, we assume just a one-to-one

¹different from the virtual CPU concept inside hypervisors

mapping between threads and VCPUs. A thread is bound to a VCPU, which is then scheduled on a core.

A local scheduling queue for each core orders VCPUs using the Rate-Monotonic Scheduling (RMS) policy [19], which is a static priority preemptive scheduling algorithm. With this approach, VCPU priorities are inversely proportional to their periods. RMS has several valuable properties. First, it provides analyzable bounds on the total CPU utilization of a set of VCPUs, within which each VCPU’s real-time service requirement can be guaranteed. Second, in overload situations, RMS guarantees service to the highest priority subset of VCPUs for which there are sufficient resources. RMS analysis shows that for large numbers of VCPUs, a core guarantees service to a set of VCPUs if their total utilization does not exceed 69%. In practice, feasible schedules are possible for higher utilizations (e.g., if all VCPUs’ periods are harmonically related).

Scheduling Model. Each VCPU with available budget at the current time operates in *foreground mode*. When a VCPU depletes its budget it enters *background mode*, where it will only be scheduled if there are no other runnable foreground VCPUs on the same core. A core is said to be in background mode when all VCPUs assigned to it are in background mode, otherwise it is in foreground mode. RMS is used only when a core is in foreground mode. When a core turns into background mode, we take a fair-sharing approach to scheduling VCPUs. The scheduler attempts to equally distribute the amount of background mode CPU time (BGT) each VCPU consumes.

The foreground mode, together with the corresponding CPU reservation, is used to guarantee an application’s base-level service quality, while the use of BGT is to further improve its progress. This is beneficial to applications that improve the resolution, or quality, of their results when granted extra computation time [20, 27]. It also provides a performance lower bound to batch, or other CPU-intensive, workloads. Nevertheless, BGT should be allocated cautiously in order to avoid excessive cache or memory bus contention, which will be discussed next.

Memory Throttling. Shared memory bus contention on multicore platforms is one of the major causes of unpredictable application performance, especially when considering the large volume of streaming sensor data (e.g., 3D LIDAR) in modern embedded systems. DRAM accesses on one core might incur delays due to concurrent accesses on other cores. One approach to address this issue is to regulate the rate of DRAM references (*throttling*), so that each core cannot exceed a pre-defined bandwidth threshold over a period of time [46]. However, our previous work [44] suggests that rate-based memory throttling has several drawbacks. Instead, we have developed a latency-based throttling mechanism. Specifically, we measure memory traffic by directly looking at the average latency to service DRAM memory requests. Our system uses the PMU to efficiently monitor the

average memory request latency. Intel Sandy Bridge and more recent processors provide two uncore performance monitoring events: `UNC_ARB_TRK_REQUEST.ALL` and `UNC_ARB_TRK_OCCUPANCY.ALL`. The first event counts all memory requests going to the memory controller request queue (*requests*), and the second one counts bus cycles weighted by the number of pending requests in the queue (*occupancy*). For example, in Figure 4, request r_1 arrives at time 0 and finishes at time 2. r_2 and r_3 both arrive at time 1 and complete at time 5. At the end of this 5-cycle period, $occupancy = 10$, $requests = 3$. We then derive the average latency (cycles) per request as follows:

$$latency = \frac{occupancy}{requests}$$

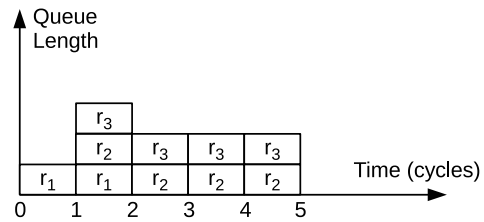

Figure 4. Example of Occupancy and Requests

A bus monitoring thread periodically updates the average latency for the entire system. Memory throttling starts when the observed average latency hits a system-configured threshold, which is platform-dependent. Throttling is only applied to a core in background mode, in which case surplus CPU time is not allocated to VCPUs and the core is switched to an idle state during its background mode. This reduces contention on the memory bus and the shared caches, thus helping VCPUs on other cores make greater progress in their foreground mode. Instead of simply disabling the cores with the most DRAM traffic, we adopt a proportional throttling scheme. Basically, cores generating more traffic are throttled for longer times.

4.3 vLib OS: Linux

We use the Ubuntu Server 14.04.5 (4.4.0 kernel) as our single vLib OS. One CPU core is dedicated to the Linux vLib OS, while the rest of cores are assigned to Quest. Virtualization is simplified by applying a patch comprising approximately 100 lines of code (LOC) to the Linux kernel. This limits Linux’s view of available physical memory, and adjusts I/O device DMA offsets to account for memory virtualization. To Linux, most of the processor capabilities are exposed except those associated with VT-x and PMU.

vlibShm. The design of the vlibShm modules, both in the master OS and the vLib OS, are very similar to each other, so we focus on our Linux side implementation for brevity. A communication channel’s physical memory is outside of Linux’s memory range and cannot be easily mapped into the vLib server. The vlibShm kernel module we have developed

is specifically designed to handle this. The server calls `mmap` into the module, passing in the machine physical address of the channel and its memory size, which are returned by the hypervisor. `vlibShm` then creates a `vm_area_struct` object with a customized page fault handler. When a page (A) inside the channel is accessed for the first time, a page fault occurs and the handler is invoked. This leads to the allocation of a page (B) within Linux’s memory range. B ’s guest physical address is then passed to the hypervisor through a hypercall, together with the machine physical address of page A . An EPT entry rewrite is performed in the hypercall so that the channel’s page A now maps to a legitimate memory address (B) in Linux.

4.4 Discussion

In this prototype, our goal is to combine the timing predictability of an RTOS and the rich body of software available on a GPOS. The RTOS hosts the time-critical and latency-sensitive tasks or control loops, which are required to ensure the safety of our evaluation platform 5. At the same time, we take advantage of the abundant commodity software, including vision, data logging and communication code hosted on Linux. Our system design not only allows us to combine legacy and custom software, but also enables fine-grained resource control required to achieve strong performance isolation.

Given our design goals, we adopted a partitioning hypervisor for maximum predictability and fast I/O manipulation. The downside of this approach is that, when a vLib OS is not servicing requests its assigned CPUs are unused. We believe this is an appropriate tradeoff when targeting real-time systems or general systems with tight tail latency requirements. However, when higher resource utilization is desired, a traditional hypervisor with hardware resource multiplexing can be used. Through CPU multiplexing, a vLib call would cause a VM switch and CPU utilization can be increased. However, we pay the cost of VM switching, in terms of pipeline stalls, cache and TLB flushing.

In our implementation, a significant development burden has been avoided by exploiting the vLibOS model. Rather than rewriting the scheduler to manage the threads associated with vLib OSes side by side with native Quest threads (or VCPUs), we treat the execution of the former as a special (*remote*) state of the latter. As a consequence, the modification to the scheduler in Quest is minimal (< 50 LOC). This shows how easy it is to make an OS compatible with vLibOS. Admittedly, this approach poses two disadvantages: 1) running services from N vLib OSes concurrently would require at least N cores dedicated to the master OS; 2) while the client thread is busy waiting, it cannot yield its CPU before depleting its current budget. The client-side CPU cannot do additional useful work even if there is no contention on platform resources. To avoid the utilization issue, one can rewrite the master OS scheduler to manage different types of threads separately. However, as demonstrated in our eval-

uation section, our model affords us the luxury of doing this only when needed. Our existing platform has sufficient resources to meet our application goals without this optimization.

We have made a design choice to not support asynchronous vLib calls in real-time systems. With blocking calls, critical and non-critical code (including Linux services) have temporal separation within a thread. If an asynchronous vLib call is made, then the critical code and non-critical code would be running simultaneously on different cores, impacting each other when accessing shared resources. The added contention would make it even harder to guarantee predictable execution on multicore platforms.

While our vLibOS prototype uses a research RTOS as the master and a mature legacy OS as the slave vLib OS, this need not be the case. In fact, a full-blown OS such as Linux could be the master as well. Such an architecture can be exploited to achieve Monolithic kernel decomposition [23]. Similarly it is not necessary for the slaves to be commodity OSes, rather it is equally viable to construct a runtime in which several specialized slave OSes are included. For example, specialized new OS kernels [6, 25] can be forked by the master to perform specific and highly optimized tasks (e.g., network I/O). Mixtures of specialized OSes allow developers to focus their effort on optimizing one service while delegating other services to general-purpose OSes. Unlike hybrid systems that lack isolation amongst kernels [24, 31], our approach provides security and performance isolation for the master OS.

Although our prototyping effort has focused on a particular platform, the techniques it introduces for controlled interactions between the master and slaves are applicable to other situations. Achieving higher utilization in data centers leads to dramatic energy and cost savings [41]. Our architecture provides a VM-based framework to construct cloud runtimes in which high-priority service applications with stringent QoS requirements are consolidated with lower-priority batch and best effort workloads on the same hardware nodes. As is demonstrated in our evaluation, despite using virtualization, it is possible to achieve precise resource throttling and isolation between VMs even with respect to low-level resources such as shared caches and memory buses. For instance, vLibOS can be used to structure a Xen-based cloud environment where the Dom0 acts as a master OS and is extended with contention management policies.

5. Evaluation

In this section, we evaluate our vLibOS implementation using the hardware platform as shown in Figure 5 and Table 1. The autonomous ground vehicle houses a custom-made PC. Only three cores are enabled in the firmware, for the purposes of running all needed tasks and to conserve energy usage from the main battery powering the vehicle. A GeForce GT 710 GPU is used because of its relatively small form-

factor, single PCIE slot requirement, fanless design and low power consumption.

Processor	Intel Core i5-2500k quad-core
Caches	6MB L3 cache
Memory	4GB 1333MHz DDR3
GPU	MSI GeForce GT 710 2GB
Camera	Logitech QuickCam Pro 9000
LIDAR	Hokuyo URG-04LX-UG01

Table 1. Hardware Specification



Figure 5. Autonomous Vehicle Platform

We assigned two of the three cores to Quest and one to Linux. Our hypervisor and Quest relied on an in-RAM file system while Linux used a USB drive for its storage. Both servo controller and LIDAR (mission-critical tasks) were connected through serial ports. Based on this system requirement, we partitioned serial ports to Quest and granted exclusive access of the GPU and USB stack (camera and storage) to Linux.

5.1 vLib Call Overhead

In this experiment, we examined the overhead of the vLib call mechanism. We started by measuring VM entry/exit costs followed by the cost of making a vLib call. We ran a test thread in Quest and a vLib server in Linux. The test thread establishes a communication channel and keeps making vLib calls without input data. The vLib server receives requests and immediately signals the completion without performing any services. To avoid the impact of scheduling in Quest, we measured the time difference T_1 between when the thread entered the kernel and when it was about to return to user space. To avoid Linux scheduling overheads, we measured the time, T_2 , between when `vLib_listen()` was about to return from the hypervisor (for servicing new requests) and when the next `vLib_listen()` call entered into the hypervisor (to generate a completion signal). The vLib call overhead is represented as $T_1 - T_2$. For the remote descheduling cost, we also measured the time difference between the moment the Quest kernel sent out an IPI and when a VM exit was

completed on the Linux core. Finally, we also measured the execution time of our customized page fault handler as the cost of mapping a single-page communication channel into Linux. All measurements were averaged over 1000 times and are shown in Table 2. Note that the channel is mapped only when it is accessed for the first time. It is not on the critical path of the vLib calls.

	VM Entry	VM Exit	vLib Call	Remote Desched	Channel Mapping
CPU Cycles	531	481	4754	1153	2377

Table 2. Mechanism Overhead

5.2 Performance of Partitioned I/O Devices

Our partitioning hypervisor incurs minimum overhead for guest I/O operations. To measure this overhead, we evaluated the GPU performance in the Linux vLib OS using an open source neural network application, Darknet [28]. Although there are other popular deep learning frameworks available, we chose Darknet because of its support for 32-bit platforms. Darknet is implemented in C and CUDA with high efficiency and only a few dependencies. We believe it is well suited to embedded applications.

In this experiment, we compared the performance of running Darknet in the stand-alone Linux (vanilla Linux) and Linux running on top of Quest-V (vLib Linux). Both Linux kernels were built without SMP support for fair comparison. The vLib Linux still retains execution control over its CPU since the vLib server was not started for this experiment. We measured the execution time of the Darknet image classification operation (CUDA code) on the GPU for both systems. The results were averaged over 1000 operations on the same single image and are shown in Table 3. As can be seen, the vLib Linux achieved similar GPU performance (7% slowdown) comparing to the vanilla Linux. Notice that part of the slowdown comes from the memory virtualization overhead.

vanilla Linux	859	vLib Linux	920
---------------	-----	------------	-----

Table 3. GPU Performance (10^6 CPU cycles)

5.3 Effectiveness of Memory Throttling

To evaluate the effectiveness of the Quest memory throttling mechanism, we introduced a memory-intensive micro-benchmark, `m_jump`, to measure the memory bus performance (Listing 2). It operates on a 6MB data array, which is large enough to occupy the entire L3 cache. The benchmark writes to the first 4 bytes of every 64 bytes in the array. As every cache line is 64 bytes, this causes the entire cache to be filled. After every write, `m_jump` jumps 8KB forward in order to avoid reusing data from DRAM row buffers [44].

It is worth noting that caches cannot be disabled for this experiment, even though our focus is on memory bus performance. If caches were disabled, every instruction needs to be fetched from memory, effectively forcing CPUs to run at the same speed as the memory bus and reducing the likelihood of bus congestion.

Listing 2. *m_jump*

```
byte array[6M];
for (uint32 j = 0; j < 8192; j += 64)
    for (uint32 i = j; i < 6M; i += 8192)
        array[i] = i;
```

We set up three groups of experiments, each with a different CPU foreground utilization (C/T) for *m_jumps*. In each group, we ran five 10-minute experiments for comparison. The first experiment (*alone*) ran a single *m_jump* under Quest, without a co-runner. At the end of the experiment, we recorded *m_jump*'s instructions retired only in the foreground mode (*FG Inst*). For the second (*quest*) and the third (*quest + mem*) experiments, two *m_jumps* were started at the same time on different cores in Quest. We disabled memory throttling for the second experiment and enabled it for the third. We measured the *FG Inst* for the first of the two *m_jumps* for both experiments. In the fourth experiment (*linux*), the first *m_jump* was started in Quest while the second was started in Linux. Memory throttling was enabled in Quest. The performance of the *m_jump* in Quest was measured. The last experiment (*linux + mem*) was similar to the fourth, but the *m_jump* in Linux was invoked by a Quest thread through a single vLib call (timeout set to null) so that memory throttling could be applied to Linux.

In group one (U=10%), the first *m_jump* was bound to a VCPU with C=10, T=100, where the time was in milliseconds. For the second *m_jump*, C=9, T=90. We refer to this setting as {C=(10, 9), T=(100, 90)}. The CPU utilization of both threads were 10% but the periods (T's) were set differently to reduce the likelihood of memory accesses occurring all together [44]. When running *m_jump* in Linux, there was no VCPU assignment. The VCPU with C=9 and T=90 was assigned to the Quest thread performing the vLib call in the fifth experiment. For group two (U=30%) and group three (U=60%), VCPU settings were {C=(30,27), T=(100, 90)} and {C=(60,54), T=(100, 90)}, respectively. Figure 6 shows the *FG Inst* of the first *m_jump* in different cases.

Comparing the *linux* case to the *alone* base case, we see that having uncontrolled bus contention inside Linux leads to a significant performance drop for real-time threads running in Quest. If memory throttling is applied to Linux using our unified scheduling mechanism, as in *linux + mem*, a large reduction in performance slowdown is achieved. In group U=10%, there is a 50% reduction in slowdown.

As we increase the CPU utilization of *m_jump*, its foreground performance increases correspondingly, due to increased foreground time. However, background time decreases at the same time. With less background time, the

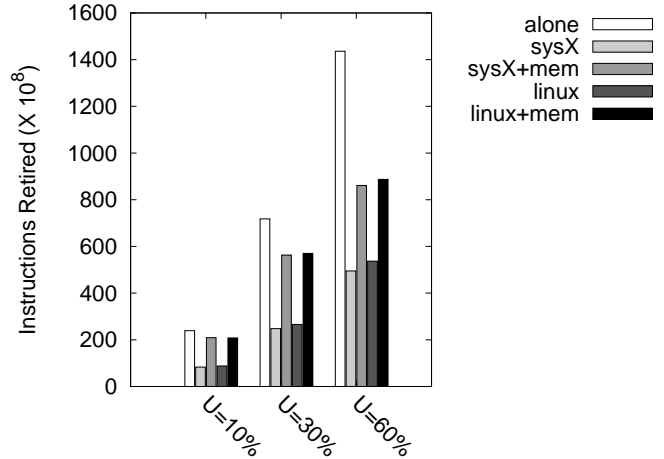

Figure 6. Effective Memory Throttling

effectiveness of memory throttling is reduced because there is less slack time to stall execution on individual cores.

5.4 Autonomous Driving Case Study

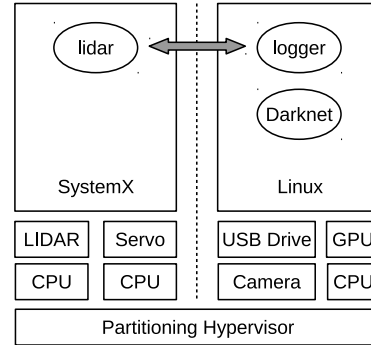

Figure 7. Autonomous Driving System

We then tested Quest-V using a real-time application involving an autonomous ground vehicle. This system (see Figure 7) consists of a real-time program *lidar* and two Linux programs, *logger* and *Darknet*. *lidar* takes LIDAR data as input and makes steering decisions to avoid objects. Meanwhile it dumps data to a 4MB memory buffer, which is shared with the *logger*. The *logger* periodically checks the buffer and saves data to a log file in the USB drive when the buffer is full. Saved data is used for offline diagnostics. *Darknet* runs side by side in Linux, reading camera frames and performing object classification, which is useful in autonomous vehicle control. For example, *Darknet* is able to identify traffic signs while LIDAR is not.

We considered the *lidar* as the most critical part of the system, so it was placed in Quest. Data logging and object classification improve quality of service, but their failure is tolerable as long as obstacle avoidance is working. Although less critical, implementing them from scratch would take significant engineering effort. Using a legacy Linux imple-

mentation of Darknet, with data logging, greatly reduced the time to build our mixed-criticality system.

In our object avoidance solution, the LIDAR device sends out distance data (around 700 bytes) every 100 ms. Periodically, *lidar* decodes the received data and scans object distances from all angles (240 degrees) in order to identify objects within a certain distance. If it finds a nearby object directly in front of the vehicle, it then looks for the closest open space either on the left side or on the right side. From the example in Figure 8, since $\alpha < \beta$, a left turn decision will be made.

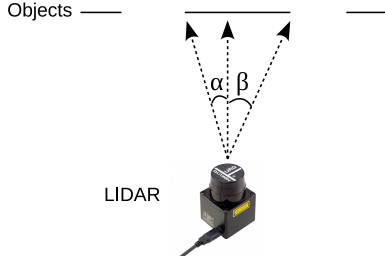

Figure 8. Object Avoidance Algorithm

In our evaluation, we divided experiments into 3 cases. In the first one (*lidar*), *lidar* was running in Quest with a VCPU configured with $\{C=12, T=40\}$. Although the logger was started in Linux as well, during the whole experiment time, the shared buffer did not fill to capacity. Thus, the logger did not perform any task. We consider this case as *lidar* running alone on the platform. This allows us to focus on evaluating only the performance impact from co-running Darknet later. We will not mention the logger again in the experiment description that follows.

In every period, we measured the execution time of *lidar* from right after it received LIDAR data to the end of its object avoidance algorithm. 2000 samples were taken during the experiment. In the second case (*lidar+Darknet w/o mem*), we simultaneously ran *lidar* in Quest and Darknet in Linux. In Linux, we did not start a vLib server, so Linux still had control over its own execution. The same measurement was carried out. The last experiment (*lidar+Darknet w/ mem*) was similar to the second, except a vLib server ran in Linux and Quest acquired full system control. A Quest thread (*client*) was created with VCPU $\{C=12, T=40\}$. Immediately after starting, it made a blocking vLib call to Linux with timeout set to null. Without sending out a request completion signal, the server simply terminated itself. Darknet then kept running inside Linux with the *client*'s CPU budget, so that memory throttling could be applied.

From Figure 9, we can see that *lidar*, when running alone inside Quest, has a very stable performance. When Darknet starts competing for shared resources in case *lidar+Darknet w/o mem*, *lidar* suffers from increased performance variation. The worst case execution time we observed was around 24000 CPU cycles, which is twice the average. This is because Linux was not running a vLib server and could not

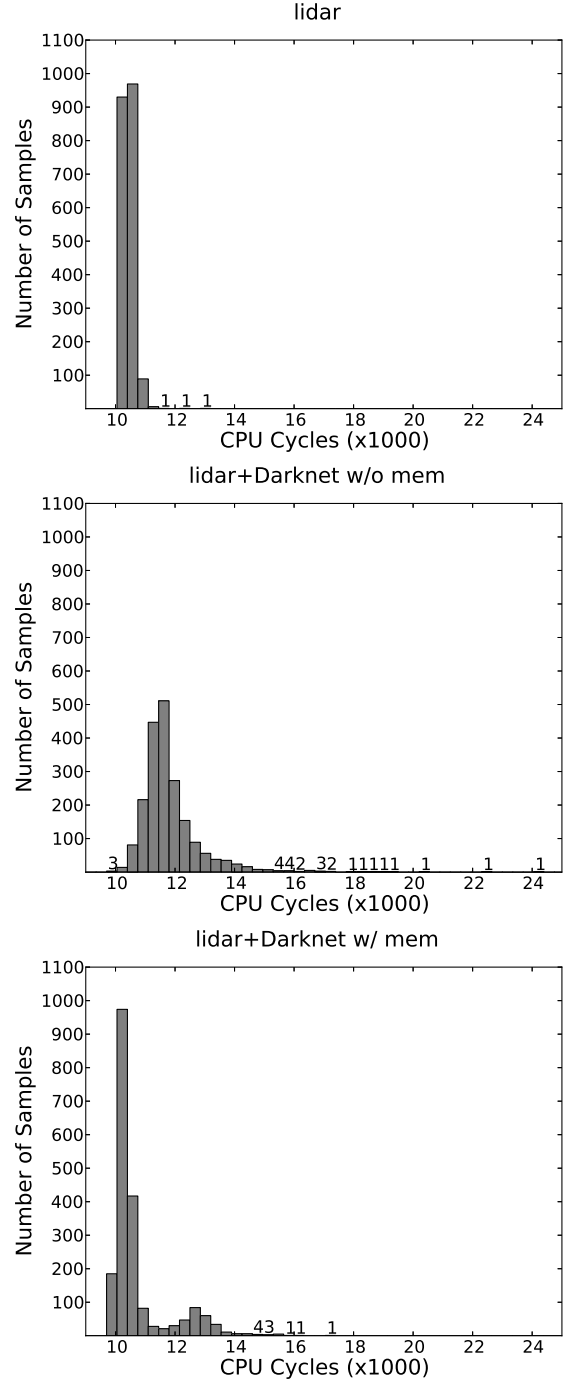

Figure 9. *lidar* Performance in Quest-V

be controlled by Quest. When the vLib call mechanism was enabled in case *lidar+Darknet w/ mem*, memory bus contention was effectively managed, leading to reduced performance variation. The worst case execution time dropped to around 17000 cycles.

It is worth mentioning that the *lidar* program's working set fits into the private L1/L2 caches. This explains why the *lidar*'s average execution time does not increase as much as we would expect from the previous section 5.3, in the pres-

ence of memory bus contention. However, more advanced LIDAR devices, better object avoidance algorithms and more complicated sensor fusion algorithms all contribute to a larger memory footprint of a real-time program. As a result, memory bus management would become essential.

For comparison, we also investigated how a vanilla Linux would perform on our autonomous vehicle. Ideally, we would use the RT-PREEMPT patch for Linux, which improves performance for real-time tasks. However, the Nvidia GPU driver did not support the real-time patch, so we were restricted to using an unpatched SMP Linux system.

For the first experiment (*lidar*), we pinned *lidar* to a core together with a CPU hog, which runs an empty while loop. Since *lidar* itself runs only periodically, it does not create much workload for the CPU. If we do not assign a hog on the same CPU, Linux performs Dynamic Voltage and Frequency Scaling (DVFS) on the CPU, thereby decreasing its frequency. This unnecessarily slows down the execution of *lidar* and impacts our measurements. We also set the real-time scheduling class SCHED_FIFO to *lidar* with the highest priority in order to avoid preemption. The execution time of *lidar*'s periodic task was measured over 2000 samples. Next, we put Darknet on another CPU and repeated the same experiment (*lidar*+*Darknet*). Results are shown in Figure 10.

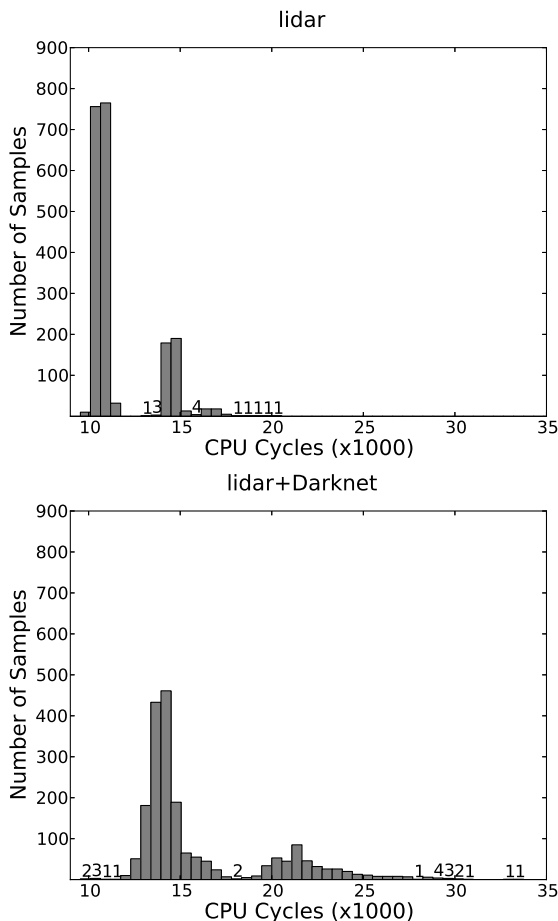

Figure 10. *lidar* Performance in Vanilla Linux

As Linux is not designed for real-time applications, *lidar* experienced noticeable performance variation even running alone. With the presence of interference by Darknet, both the average and worst case execution time were prolonged significantly. Comparing these results with the results from Figure 9, we believe Quest-V provides better real-time service to the lidar application.

6. Related Work

6.1 OS Evolution Strategies

OSKit [12] is an early work with an explicit goal to ease new OS development. It provides a set of commonly used OS components, like bootstrapping, architecture-specific manipulation and protocol stacks. Modularization and encapsulation of legacy code via a glue layer allow developers to concentrate their engineering effort on innovative features. However, it is hard to achieve comparable performance with existing systems if strict modularization is used. Also, creating an adaptation layer may not be an easy task.

There have been a number of research efforts focusing on OS structure and extensibility. Extensible operating systems research [33] aims at providing applications with greater control over the management of their resources. For example, the exokernel [11] tries to efficiently multiplex hardware resources among applications that utilize library OSes. Resource management is thus delegated to library OSes, which can be readily modified to suit the needs of individual applications. SPIN [7] is an extensible operating system that supports extensions written in the Modula-3 programming language. Interaction between the core kernel and SPIN extensions is mediated by an event system, which dispatches events to handler functions in the kernel. By providing handlers for events, extensions can implement application-specific resource management policies with low overhead.

Exokernels, library OSes like Drawbridge [26] and uniker-nels [21] all view OS services as a set of application libraries. vLibOS differs from them by treating an entire legacy OS as a single library whose execution is mediated by a master OS. With vLibOS there is no need to reimplement a legacy OS as a set of library services.

Some work have attempted to virtualize existing OSes, which offer services to a new OS. User-Mode Linux [10] and L4Linux [40], for example, implement a modified Linux inside a user-level address space on top of a host OS. Libra [2], on the other hand, relies on virtualization technologies for hosting unmodified guest services. EbbRT [29] employs a similar approach, enabling kernel innovation in a distributed environment. In EbbRT, services are offloaded between machines running light-weight kernels and full-featured OSes. Offloading is facilitated by an object model that encapsulates the distributed implementation of system components.

Dune [5] uses hardware virtualization to expose privileged hardware features to user-level processes, improving

efficiency for certain applications such as garbage collection. As with extensible kernels, the aim is to enrich the functionality within existing systems. In contrast, vLibOS helps develop custom OSES that implement new services based on legacy functionality in separate VMs.

VirtuOS [23] delegates part of its services to other VMs through an exception-less system call mechanism [34]. The execution of services is controlled by each service domain instead of the primary domain. An exception-less system call can be implemented on top of our vLib call. However, VirtuOS, as with Nooks [36], focuses on safe isolation of existing system components rather than recycling legacy components for new OSES, as covered in this paper. That being said, vLibOS is able to restructure the functionality of monolithic kernels across separate protection domains.

FusedOS [24] proposes the use of a full-blown OS as a master OS, which spawns light-weight kernels to a subset of CPUs, but without virtualization. Shimosawa et al. [31] further formalize this hybrid kernel design and define a corresponding interface. Developers are able to implement new features in light-weight kernels, while requesting legacy services through cross-kernel service delegation. The downside is that, without virtualization, protection between kernels is not enforced. Also, a light-weight kernel does not have the ability to manage global resources in order to maintain its desired QoS, as is done in vLibOS.

Commercial embedded systems like PikeOS [1] and QNX [37] rely on their own in-kernel virtualization technologies to support legacy software. However, contention for shared hardware resources is not addressed. While the RTS Hypervisor [13] throttles the memory throughput for non-critical VMs, it does so using a demonstrably inferior rate-based (bandwidth) threshold, rather than a latency-based threshold used in our system. Finally, Litmus^{RT} [?] provides extensions to Linux to support prototype development of real-time schedulers and synchronization protocols. However, it does not focus on the enforcement of temporal and spatial isolation between custom and legacy components, as addressed by vLibOS.

6.2 Multicore Resource Management

The effects of shared caches, buses and DRAM banks on program execution have been studied in recent years. Page coloring [9, 30] is a commonly used software technique to partition shared caches on multicore processors. Tam et al. [39] implemented static cache partitioning with page coloring in a prototype Linux system, improving performance by reducing cache contention amongst cores. COLORIS [43] demonstrated an efficient method for dynamic cache partitioning, enhancing system QoS. In the meantime, hardware vendors developed their own cache protection mechanisms (e.g., Intel CAT, ARM cache lockdown) so that caches are better managed.

In terms of memory bus contention, Blagodurov et al. [8] identified it as one of the dominant causes of performance

slowdown on multicore processors and tried to avoid running memory intensive applications concurrently. Later, MemGuard [46] was developed to control memory bandwidth usage across different cores. Each core is assigned a memory budget, which limits the number of DRAM accesses in a specified interval. To improve bandwidth utilization, MemGuard predicts the actual bandwidth usage of each core in the upcoming period. For cores that do not use all their budgets, they contribute their surplus to a global pool, which is shared amongst all cores. PALLOC [45] is another approach that uses a bank-aware memory allocator to assign page frames to applications so that DRAM bank-level contention is avoided.

Dirigent [47] is a system that regulates the progress of latency-sensitive programs in the presence of non-latency-sensitive programs. It reduces performance variation of specific applications in the presence of memory contention. The system works by first offline profiling the execution of latency-sensitive programs when running alone. An online execution time predictor/controller then adjusts resources available to them during the normal runs, to ensure their latency constraints in the presence of contention. This contrasts with vLibOS's way of throttling cores to avoid memory contention.

7. Conclusions and Future Work

This paper presents vLibOS, a master-slave paradigm that integrates services from multiple OSES into a single, custom system. The approach allows pre-existing OSES to provide legacy services to new systems with specialized QoS requirements. The new system features are implemented in a master OS that calls upon legacy system software in different virtual machines. We argue that the master OS should manage shared hardware resources on the platform for meeting its targeted QoS. As it is able to coordinate and schedule the execution of services in other VMs, inter-VM performance isolation is greatly improved. This is critical to systems that require temporal predictability (e.g., real-time guarantees).

In our prototype system, Quest-V, we developed a partitioning hypervisor with vLibOS API support. The proposed unified scheduling mechanism enables legacy services to be an extension of a client thread in the master OS, thus granting the control of a Linux VM to the master. The master, Quest, then uses a latency-based memory throttling technique to regulate the shared memory bus. This avoids excessive concurrent memory accesses from separate cores that would otherwise lead to unpredictable execution times of real-time services. Our experiments show the benefits of the vLibOS system design.

Future work will investigate the benefits and tradeoffs of the vLibOS approach for a diverse range of applications with timing, safety and security requirements (e.g., smart Internet-of-Things, cloud systems). We will also work on ways to improve the utilization of cores in a vLibOS system.

References

- [1] SYSGO AG. 2017. The PikeOS Hypervisor. <https://www.sysgo.com/>. (2017).
- [2] Glenn Ammons, Jonathan Appavoo, Maria Butrico, Dilma Da Silva, David Grove, Kiyokuni Kawachiya, Orran Krieger, Bryan Rosenburg, Eric Van Hensbergen, and Robert W. Wisniewski. 2007. Libra: A Library Operating System for a JVM in a Virtualized Execution Environment. In *Proceedings of the 3rd International Conference on Virtual Execution Environments (VEE '07)*. ACM, New York, NY, USA, 44–54.
- [3] AUTOSAR. 2015. AUTomotive Open System ARchitecture. (2015). <http://www.autosar.org>.
- [4] Andrew Baumann, Paul Barham, Pierre-Evariste Dagand, Tim Harris, Rebecca Isaacs, Simon Peter, Timothy Roscoe, Adrian Schüpbach, and Akhilesh Singhanian. 2009. The Multikernel: A New OS Architecture for Scalable Multicore Systems. In *Proceedings of the ACM SIGOPS 22Nd Symposium on Operating Systems Principles (SOSP '09)*. ACM, New York, NY, USA, 29–44.
- [5] Adam Belay, Andrea Bittau, Ali Mashtizadeh, David Terei, David Mazières, and Christos Kozyrakis. 2012. Dune: Safe User-level Access to Privileged CPU Features. In *Presented as part of the 10th USENIX Symposium on Operating Systems Design and Implementation (OSDI 12)*. USENIX, Hollywood, CA, 335–348.
- [6] Adam Belay, George Prekas, Ana Klimovic, Samuel Grossman, Christos Kozyrakis, and Edouard Bugnion. 2014. IX: A Protected Dataplane Operating System for High Throughput and Low Latency. In *11th USENIX Symposium on Operating Systems Design and Implementation (OSDI 14)*. USENIX Association, CO, 49–65.
- [7] Brian N. Bershad, Stefan Savage, Przemyslaw Pardyak, Emin Gum Sirer, Marc Fiuczynski, and Becker Eggers Chambers. 1995. Extensibility, Safety, and Performance in the SPIN Operating System. In *Proceedings of the 15th ACM Symposium on Operating Systems Principles*. Copper Mountain, Colorado, 267–284.
- [8] Sergey Blagodurov, Sergey Zhuravlev, and Alexandra Fedorova. 2010. Contention-Aware Scheduling on Multicore Systems. *ACM Trans. Comput. Syst.* 28, 4, Article 8 (Dec. 2010), 45 pages.
- [9] Edouard Bugnion, Jennifer M. Anderson, Todd C. Mowry, Mendel Rosenblum, and Monica S. Lam. 1996. Compiler-directed Page Coloring for Multiprocessors. In *Proceedings of the 7th International Conference on Architectural Support for Programming Languages and Operating Systems*. 244–255.
- [10] Jeff Dike. 2006. The User Mode Linux Kernel. <http://user-mode-linux.sourceforge.net/>. (2006).
- [11] D. R. Engler, M. F. Kaashoek, and J. O’Toole, Jr. 1995. Exokernel: An Operating System Architecture for Application-level Resource Management. In *Proceedings of the Fifteenth ACM Symposium on Operating Systems Principles (SOSP '95)*. ACM, New York, NY, USA, 251–266.
- [12] Bryan Ford, Godmar Back, Greg Benson, Jay Lepreau, Albert Lin, and Olin Shivers. 1997. The Flux OSKit: A Substrate for Kernel and Language Research. In *Proceedings of the Sixteenth ACM Symposium on Operating Systems Principles (SOSP '97)*. ACM, New York, NY, USA, 38–51.
- [13] Real-Time Systems GmbH. 2017. RTS Hypervisor. <https://www.real-time-systems.com/>. (2017).
- [14] Steven Hand, Andrew Warfield, Keir Fraser, Evangelos Kotsovinos, and Dan Magenheimer. 2005. Are Virtual Machine Monitors Microkernels Done Right?. In *Proceedings of the 10th Conference on Hot Topics in Operating Systems - Volume 10 (HOTOS'05)*. USENIX Association, Berkeley, CA, USA, 1–1.
- [15] M. Jones. 2009. Inside the Linux 2.6 Completely Fair Scheduler. <https://www.ibm.com/developerworks/linux/library/l-completely-fair-scheduler/>. (December 15 2009).
- [16] Paul C. Kocher, Joshua Jaffe, and Benjamin Jun. 1999. Differential Power Analysis. In *Proceedings of the 19th Annual International Cryptology Conference on Advances in Cryptology (CRYPTO '99)*. Springer-Verlag, London, UK, UK, 388–397.
- [17] Ye Li, Richard West, and Eric Missimer. 2014. A Virtualized Separation Kernel for Mixed Criticality Systems. In *Proceedings of the 10th ACM SIGPLAN/SIGOPS International Conference on Virtual Execution Environments (VEE '14)*. ACM, New York, NY, USA, 201–212. DOI: <http://dx.doi.org/10.1145/2576195.2576206>
- [18] J. Liedtke. 1995. On Micro-kernel Construction. In *Proceedings of the Fifteenth ACM Symposium on Operating Systems Principles (SOSP '95)*. ACM, New York, NY, USA, 237–250.
- [19] C. L. Liu and James W. Layland. 1973. Scheduling Algorithms for Multiprogramming in a Hard-Real-Time Environment. *J. ACM* 20, 1 (Jan. 1973), 46–61.
- [20] J. W. S. Liu, K. J. Lin, W. K. Shih, A. C. s. Yu, J. Y. Chung, and W. Zhao. 1991. Algorithms for Scheduling Imprecise Computations. *Computer* 24, 5 (May 1991), 58–68.
- [21] Anil Madhavapeddy, Richard Mortier, Charalampos Rotsos, David Scott, Balraj Singh, Thomas Gazagnaire, Steven Smith, Steven Hand, and Jon Crowcroft. 2013. Unikernels: Library Operating Systems for the Cloud. In *Proceedings of the Eighteenth International Conference on Architectural Support for Programming Languages and Operating Systems (ASPLOS '13)*. ACM, New York, NY, USA, 461–472.
- [22] Thomas Moscibroda and Onur Mutlu. 2007. Memory Performance Attacks: Denial of Memory Service in Multi-core Systems. In *Proceedings of 16th USENIX Security Symposium on USENIX Security Symposium (SS'07)*. USENIX Association, Berkeley, CA, USA, Article 18, 18 pages.
- [23] Ruslan Nikolaev and Godmar Back. 2013. VirtuOS: An Operating System with Kernel Virtualization. In *Proceedings of the Twenty-Fourth ACM Symposium on Operating Systems Principles (SOSP '13)*. ACM, New York, NY, USA, 116–132.
- [24] Y. Park, E. Van Hensbergen, M. Hillenbrand, T. Inglett, B. Rosenburg, K. D. Ryu, and R. W. Wisniewski. 2012. Fuse-dOS: Fusing LWK Performance with FWK Functionality in a Heterogeneous Environment. In *2012 IEEE 24th Interna-*

tional Symposium on Computer Architecture and High Performance Computing. 211–218.

- [25] Simon Peter, Jialin Li, Irene Zhang, Dan R. K. Ports, Doug Woos, Arvind Krishnamurthy, Thomas Anderson, and Timothy Roscoe. 2014. Arrakis: The Operating System is the Control Plane. In *11th USENIX Symposium on Operating Systems Design and Implementation (OSDI 14)*. USENIX Association, CO, 1–16.
- [26] Donald E. Porter, Silas Boyd-Wickizer, Jon Howell, Reuben Olinsky, and Galen C. Hunt. 2011. Rethinking the Library OS from the Top Down. In *Proceedings of the Sixteenth International Conference on Architectural Support for Programming Languages and Operating Systems (ASPLOS XVI)*. ACM, New York, NY, USA, 291–304.
- [27] Andrea Quagli, Daniele Fontanelli, Luca Greco, Luigi Palopoli, and Antonio Bicchi. 2009. Designing Real-time Embedded Controllers using the Anytime Computing Paradigm. In *Proceedings of the 14th IEEE International Conference on Emerging Technologies and Factory Automation*. 929–936.
- [28] Joseph Redmon. 2013–2016. Darknet: Open Source Neural Networks in C. <http://pjreddie.com/darknet/>. (2013–2016).
- [29] Dan Schatzberg, James Cadden, Han Dong, Orran Krieger, and Jonathan Appavoo. 2016. EbbRT: A Framework for Building Per-Application Library Operating Systems. In *12th USENIX Symposium on Operating Systems Design and Implementation (OSDI 16)*. USENIX Association, GA, 671–688.
- [30] Timothy Sherwood, Brad Calder, and Joel Emer. 1999. Reducing Cache Misses using Hardware and Software Page Placement. In *Proceedings of the 13th International Conference on Supercomputing*. 155–164.
- [31] T. Shimosawa, B. Gerofi, M. Takagi, G. Nakamura, T. Shirasawa, Y. Saeki, M. Shimizu, A. Hori, and Y. Ishikawa. 2014. Interface for Heterogeneous Kernels: A Framework to Enable Hybrid OS Designs Targeting High Performance Computing on Manycore Architectures. In *2014 21st International Conference on High Performance Computing (HiPC)*. 1–10.
- [32] Siemens. 2016. Jailhouse: Linux-based Partitioning Hypervisor. <https://github.com/siemens/jailhouse/>. (2016).
- [33] Christopher Small and Margo I. Seltzer. 1996. A Comparison of OS Extension Technologies. In *USENIX Annual Technical Conference*. 41–54.
- [34] Livio Soares and Michael Stumm. 2010. FlexSC: Flexible System Call Scheduling with Exception-less System Calls. In *Proceedings of the 9th USENIX Conference on Operating Systems Design and Implementation (OSDI'10)*. USENIX Association, Berkeley, CA, USA, 33–46.
- [35] Green Hills Software. 2015. INTEGRITY-178B RTOS. (2015).
- [36] Michael M. Swift, Brian N. Bershad, and Henry M. Levy. 2003. Improving the Reliability of Commodity Operating Systems. In *Proceedings of the Nineteenth ACM Symposium on Operating Systems Principles (SOSP '03)*. ACM, New York, NY, USA, 207–222.
- [37] QNX Software Systems. 2017. QNX Hypervisor. <https://www.qnx.com/>. (2017).
- [38] Jakub Szefer, Eric Keller, Ruby B. Lee, and Jennifer Rexford. 2011. Eliminating the Hypervisor Attack Surface for a More Secure Cloud. In *Proceedings of the 18th ACM Conference on Computer and Communications Security (CCS '11)*. ACM, New York, NY, USA, 401–412.
- [39] David Tam, Reza Azimi, Livio Soares, and Michael Stumm. 2007. Managing Shared L2 Caches on Multicore Systems in Software. In *Proceedings of the Workshop on the Interaction between Operating Systems and Computer Architecture*.
- [40] TU-Dresden. 2016. L4Linux. <https://l4linux.org/>. (2016).
- [41] Abhishek Verma, Luis Pedrosa, Madhukar Korupolu, David Oppenheimer, Eric Tune, and John Wilkes. 2015. Large-scale Cluster Management at Google with Borg. In *Proceedings of the Tenth European Conference on Computer Systems (EuroSys '15)*. ACM, New York, NY, USA, Article 18, 17 pages.
- [42] Steve Vestal. 2007. Preemptive Scheduling of Multi-criticality Systems with Varying Degrees of Execution Time Assurance. In *Real-Time Systems Symposium, 2007. RTSS 2007. 28th IEEE International*. IEEE, 239–243.
- [43] Ying Ye, Richard West, Zhuoqun Cheng, and Ye Li. 2014. COLORIS: A Dynamic Cache Partitioning System Using Page Coloring. In *Proceedings of the 23rd International Conference on Parallel Architectures and Compilation (PACT '14)*. ACM, 381–392.
- [44] Ying Ye, Richard West, Jingyi Zhang, and Zhuoqun Cheng. 2016. MARACAS: A Real-Time Multicore VCPU Scheduling Framework. In *Proceedings of the 37th IEEE Real-Time Systems Symposium (RTSS '16)*.
- [45] Heechul Yun, Renato Mancuso, Zheng-Pei Wu, and Rodolfo Pellizzoni. 2014. PALLOC: DRAM Bank-Aware Memory Allocator for Performance Isolation on Multicore Platforms. In *Proceedings of the 20th IEEE Real-Time and Embedded Technology and Applications Symposium (RTAS '14)*.
- [46] Heechul Yun, Gang Yao, Rodolfo Pellizzoni, Marco Caccamo, and Lui Sha. 2013. MemGuard: Memory Bandwidth Reservation System for Efficient Performance Isolation in Multi-core Platforms. In *Proceedings of the 19th IEEE Real-Time and Embedded Technology and Applications Symposium (RTAS '13)*. 55–64.
- [47] Haishan Zhu and Mattan Erez. 2016. Dirigent: Enforcing QoS for Latency-Critical Tasks on Shared Multicore Systems. In *Proceedings of the 21th ACM International Conference on Architectural Support for Programming Languages and Operating Systems (ASPLOS)*.