

Efficient Computation of the 8-point DCT via Summation by Parts

D. F. G. Coelho* R. J. Cintra† V. S. Dimitrov‡

Abstract

This paper introduces a new fast algorithm for the 8-point discrete cosine transform (DCT) based on the summation-by-parts formula. The proposed method converts the DCT matrix into an alternative transformation matrix that can be decomposed into sparse matrices of low multiplicative complexity. The method is capable of scaled and exact DCT computation and its associated fast algorithm achieves the theoretical minimal multiplicative complexity for the 8-point DCT. Depending on the nature of the input signal simplifications can be introduced and the overall complexity of the proposed algorithm can be further reduced. Several types of input signal are analyzed: arbitrary, null mean, accumulated, and null mean/accumulated signal. The proposed tool has potential application in harmonic detection, image enhancement, and feature extraction, where input signal DC level is discarded and/or the signal is required to be integrated.

Keywords

DCT, Fast Algorithms, Image Processing

1 Introduction

Discrete transforms play a central role in signal processing. Noteworthy methods include trigonometric transforms—such as the discrete Fourier transform (DFT) [1], discrete Hartley transform (DHT) [1], discrete cosine transform (DCT) [2], and discrete sine transform (DST) [2]—as well as the Haar and Walsh-Hadamard transforms [3]. Among these methods, the DCT has been applied in several practical contexts: noise reduction [4], watermarking methods [5], image/video compression techniques [2], and harmonic detection [2], to cite a few. In fact, when processing signals modeled as a stationary Markov-1 type random process, the DCT behaves as the asymptotic case of the optimal Karhunen–Loève transform in terms of data decorrelation [2]. This approximation holds true when the correlation coefficient of the related stochastic process tends to the unit, which is the case for many real signals—specially images [2]. Moreover, the recent increase in image/video processing demand for consumer electronics [6] and big data manipulation [7] emphasizes the necessity for fast and efficient DCT computation [8].

As a consequence, the 8-point DCT is adopted in several image and video coding schemes [9], such as JPEG [10], MPEG-1 [10], H.264 [11], HEVC [12], AVS China [13, p. 61], and VP-10 [13, p. 165]. Aiming at minimizing the computational cost of the DCT evaluation, a number of fast algorithms for the 8-point DCT have been proposed, including Chen’s DCT algorithm [14], Lee method [15], Loeffler algorithm [16], Feig-Winograd DCT factorization [17], and the Arai DCT [18].

Multiplication operations as required by DCT and others discrete-time transforms can be implemented via long sequences of additions, bit-shifting operation, and sign changes [19]. Thus, algorithms that require multiplications often have higher computational costs [20]. Therefore, above-mentioned methods were developed in order to reduce the overall number of multiplications [2]. The Arai DCT is particularly useful because it furnishes a scaled version of the DCT spectrum. In some applications such as harmonic detection [21, 22] and JPEG-like image compression [10, 9], the scaled DCT is often a sufficient tool. This is because in these contexts only the relative value of the spectrum is necessary. Therefore, part of the cost of computing the DCT can be avoided [2].

*D. F. G. Coelho is with the Department of Electrical and Computer Engineering, University of Calgary, Calgary, Canada.

†R. J. Cintra is with the Signal Processing Group, Departamento de Estatística, Universidade Federal de Pernambuco and the Department of Electrical and Computer Engineering, University of Calgary, Calgary, Canada. E-mail: rjdsc@de.ufpe.br

‡V. S. Dimitrov is with the Department of Electrical and Computer Engineering, University of Calgary, Calgary, Canada.

Among the fundamental mathematical tools, we separate the summation-by-parts technique [23, p. 54], which is the discrete-time counterpart for the well-known integration-by-parts method [24, p. 144]. Although applied in several contexts such as computational physics for approximate second derivatives [25], approximations of the linear advection-diffusion equation in computational fluid dynamics [26], and rapid calculation of slow converging series in electromagnetic problems [27], it has been particularly overlooked by the signal processing community. Early attempts to employ it as a numerical analysis tool are due to Boudreaux-Bartels and collaborators in the context of the DFT computation [28] and the evaluation of Fourier coefficients errors calculations [29].

The aim of this paper is to propose a new fast algorithm for the 8-point DCT computation based on the summation-by-parts formula for periodic signals [23, 30]. The introduced method is sought to achieve the theoretical minimal multiplicative complexity for the exact DCT computation [31, 32]. Moreover, to further minimize computational costs, the proposed algorithm is also sought to provide a scaled version of the DCT spectrum [2]. The proposed algorithm finds application in some important problems, such as feature detection, where DC level may not be relevant [33, 34]. Also, it can be applied to scenarios where input signal is natively accumulated (integrated) [1, p. 19]. This situation occurs in face recognition problems, where usual algorithms require data to be integrated [35, 36].

This paper is organized as follows. In Section 2, we furnish the mathematical background for the summation-by-parts technique and the DCT. Considering matrix formalism, we detail the proposed algorithm for the DCT in Section 3. In Section 4, the introduced method is assessed in terms of its computational complexity and comparisons with competing algorithms are shown. Section 5 brings final comments and remarks.

2 Mathematical Background

2.1 Summation-by-parts

The summation-by-parts technique is the discrete-time equivalent of the integration-by-parts method [23]. Let $x[n]$ and $y[n]$ be two discrete-time signals. The summation-by-parts prescribes that [23, 28]:

$$\sum_{n=0}^{N-1} x[n]y[n] = x[N]y[N] - x[0]y[0] - \sum_{n=0}^{N-1} \left(\sum_{i=0}^{n-1} x[i] \right) \cdot \Delta y[n],$$

where Δ denotes the forward difference operator given by $\Delta y[n] \triangleq y[n+1] - y[n]$ [23]. Above expression can be simplified with the assumption of the following additional weak conditions. Admitting that the considered signals are periodic with period N , it was established in [30] that:

$$\sum_{n=0}^{N-1} x[n] \cdot y[n] = - \sum_{n=0}^{N-1} \left(\sum_{i=0}^{n-1} x[i] \right) \cdot \Delta y[n]. \quad (1)$$

The above condition is not too restrictive. Indeed discrete-time Fourier analysis often assume that the input signals are periodic [1, 2, 37]. In particular, the DCT can be obtained as the solution to the harmonic oscillation problem [2].

The expression $\sum_{n=0}^{N-1} x[n] \cdot y[n]$ can be interpreted as a discrete-time transformation. Let $x[n]$ be the input signal to be transformed and $y[n] = \ker[n, k]$ be a given discrete transformation kernel for the k th transform-domain component. Therefore, we have that:

$$X[k] = \sum_{n=0}^{N-1} x[n] \cdot \ker[n, k], \quad k = 0, 1, \dots, N-1, \quad (2)$$

Table 1: Common discrete transform kernels

Transform	ker[n, k]
DFT [1]	$\exp\left(-j\frac{2\pi nk}{N}\right)$
DHT [1]	$\text{cas}\left(\frac{2\pi nk}{N}\right)$
DCT [2]	$\cos\left(\frac{\pi(2n+1)k}{2N}\right)$
DST [2]	$\sin\left(\frac{\pi}{N}\left(k+\frac{1}{2}\right)\left(n+\frac{1}{2}\right)\right)$

where $X[k]$ is the transformed output signal. Table 1 summarizes common transformation kernels. Therefore, applying (1) into (2) yields the following expression for the transform-domain components:

$$\begin{aligned} X[k] &= -\sum_{n=0}^{N-1} \left(\sum_{i=0}^n x[i] \right) \cdot \Delta \text{ker}[n, k] \\ &= -\sum_{n=0}^{N-1} z[n] \cdot \Delta \text{ker}[n, k], \quad k = 0, 1, \dots, N-1, \end{aligned} \quad (3)$$

where $z[n] = \sum_{i=0}^n x[i]$, for $n = 0, 1, \dots, N-1$. Comparing (2) with (3), we notice that the original transform expression was re-written into an alternative form where both the input data and the kernel function were processed. Notice that $z[n]$ is the output of an accumulator system for input signal $x[n]$ [1]; whereas $\Delta \text{ker}[n, k]$ derives from a forward difference system for input signal $\text{ker}[n, k]$ [1]. Although the forward difference system is not causal, this fact poses no difficulty to above formalism. This is because $\text{ker}[n, k]$ is not a random real-time sequence—but a deterministic sequence whose values are known *a priori* [19, p. 7].

Moreover, if $x[n]$ possesses null mean, then the following expression holds true:

$$z[N-1] = \sum_{i=0}^{N-1} x[i] = 0 \quad \text{and} \quad X[0] = 0.$$

For trigonometric transforms, above condition implies $X[0] = 0$ (null DC value). Therefore, (3) can be simplified and written as:

$$X[k] = -\sum_{n=0}^{N-2} z[n] \cdot \Delta \text{ker}[n, k], \quad k = 1, 2, \dots, N-1. \quad (4)$$

Above summation ranges from 0 to $N-2$. This means that the transformation matrix linked to (3) has dimension $(N-1) \times (N-1)$. This fact contrasts with the original transformation matrix, which has size $N \times N$. Thus, the summation-by-parts effected a dimension reduction of transform computation. As a consequence, the computational cost of associate algorithms is expected to be reduced.

Figure 1 depicts the overall diagram for the transform computation based on the summation-by-parts formula, when $x[n]$ is assumed to be an arbitrary signal. Notice that, if N is a power of two, both the DC removal block and the accumulation system are multiplierless operations.

2.2 Discrete Cosine Transform

The DCT is a linear transformation that maps an N -point discrete-time signal $x[n]$ into another N -point discrete-time signal $X[k]$ according to the following relationship [16]:

$$X[k] = \frac{4}{\sqrt{N}} \alpha_k \sum_{n=0}^{N-1} x[n] \cos\left(\frac{\pi(2n+1)k}{2N}\right), \quad (5)$$

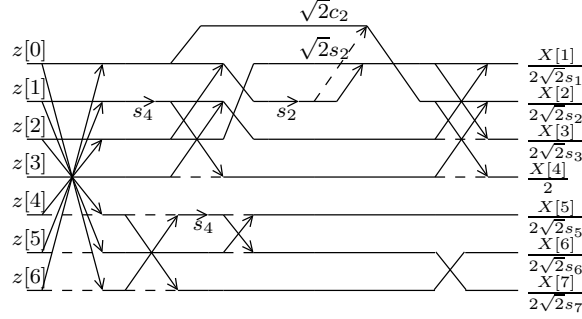

Figure 1: Block diagram of the proposed architecture.

where $k = 0, 1, \dots, N - 1$, $\alpha_0 = 1/\sqrt{2}$, and $\alpha_k = 1$, for $k > 0$. The above expression can be given a compact format by means of matrix representation. Indeed, considering signals $x[n]$ and $X[k]$ in column vector format as $\mathbf{x} = [x[0] \ x[1] \ \dots \ x[N - 1]]^\top$ and $\mathbf{X} = [X[0] \ X[1] \ \dots \ X[N - 1]]^\top$, we have that:

$$\mathbf{X} = \mathbf{C}_N \cdot \mathbf{x}, \quad (6)$$

where \mathbf{C}_N is the DCT matrix, whose (k, n) -entry is given by $\frac{4}{\sqrt{N}}\alpha_k \cos\left(\frac{\pi(2n+1)k}{2N}\right)$. For $N = 8$, we have the following transformation matrix:

$$\mathbf{C} \triangleq \mathbf{C}_8 = \sqrt{2} \cdot \begin{bmatrix} c_4 & c_4 & c_4 & c_4 & c_4 & c_4 & c_4 & c_4 \\ c_1 & c_3 & c_5 & c_7 & -c_7 & -c_5 & -c_3 & -c_1 \\ c_2 & c_6 & -c_6 & -c_2 & -c_2 & -c_6 & c_6 & c_2 \\ c_3 & -c_7 & -c_1 & -c_5 & c_5 & c_1 & c_7 & -c_3 \\ c_4 & -c_4 & -c_4 & c_4 & c_4 & -c_4 & -c_4 & c_4 \\ c_5 & -c_1 & c_7 & c_3 & -c_3 & -c_7 & c_1 & -c_5 \\ c_6 & -c_2 & c_2 & -c_6 & -c_6 & c_2 & -c_2 & c_6 \\ c_7 & -c_5 & c_3 & -c_1 & c_1 & -c_3 & c_5 & -c_7 \end{bmatrix},$$

where $c_k = \cos(k\pi/16)$, for $k = 1, 2, \dots, 7$. This particular definition of the DCT is adopted in [38, 39, 40], having been considered to derive the well-known Loeffler DCT algorithm [16]. Notice that $\sqrt{2} \cdot c_4 = 1$; therefore the DC component $X[0]$ is evaluated without multiplications [16]. In [32], Heideman introduces an in-depth mathematical analysis of the multiplicative complexity of major discrete transforms. A result from multiplicative complexity theory that is relevant to the current work is the following. If the transform blocklength is a power of two, $N = 2^r$, $r = 1, 2, \dots$, then the minimum multiplicative complexity $\mu(N)$ of the DCT has a general formula given by $\mu(2^r) = 2^{r+1} - r - 2$ [32, Theorem 6.3, p. 117]. For $N = 8$, we obtain $\mu(2^3) = 11$.

3 DCT Computation via Summation-by-parts

In this section, we apply the summation-by-parts technique to propose an alternative computation of the 8-point DCT. Next we analyze the resulting expressions in order to derive a fast algorithm by means of matrix factorization.

3.1 Matrix Formalism

To facilitate the development of the sought DCT fast algorithm, we re-cast the summation-by-part formula into matrix formalism. But, first, the forward difference operator needs to be adapted to manipulate matrices. Let \mathbf{M} be a square matrix. Then $\Delta\mathbf{M}$ is the matrix resulted from cyclically applying the forward difference operator to each row of \mathbf{M} .

Therefore, considering the summation-by-parts formula shown in (4), we have that (6) can be written according

to:

$$\mathbf{X} = \Delta\mathbf{C} \cdot \mathbf{z},$$

where the N -point vector $\mathbf{X} = [X[0] \ X[1] \ \dots \ X[N-1]]^\top$ represents the DCT spectrum, $\mathbf{z} = [z[0] \ z[1] \ \dots \ z[N-1]]^\top$ is the accumulated input signal, and

$$\Delta\mathbf{C} = \sqrt{2} \times \begin{bmatrix} 0 & 0 & 0 & 0 & 0 & 0 & 0 & 0 \\ c_3 - c_1 & c_5 - c_3 & c_7 - c_5 & -2c_7 & c_7 - c_5 & c_5 - c_3 & c_3 - c_1 & 2c_1 \\ c_6 - c_2 & -2c_6 & c_6 - c_2 & 0 & c_2 - c_6 & 2c_6 & c_2 - c_6 & 0 \\ -c_3 - c_7 & c_7 - c_1 & c_1 - c_5 & 2c_5 & c_1 - c_5 & c_7 - c_1 & -c_3 - c_7 & 2c_3 \\ -2c_4 & 0 & 2c_4 & 0 & -2c_4 & 0 & 2c_4 & 0 \\ -c_1 - c_5 & c_1 + c_7 & c_3 - c_7 & -2c_3 & c_3 - c_7 & c_1 + c_7 & -c_1 - c_5 & 2c_5 \\ -c_2 - c_6 & 2c_2 & -c_2 - c_6 & 0 & c_2 + c_6 & -2c_2 & c_2 + c_6 & 0 \\ -c_5 - c_7 & c_3 + c_5 & -c_1 - c_3 & 2c_1 & -c_1 - c_3 & c_3 + c_5 & -c_5 - c_7 & 2c_7 \end{bmatrix}.$$

Considering the sum-to-product identities [41, p. 72] and symmetry identities [23], the entries of the matrix $\Delta\mathbf{C}$ can be given a multiplicative form, as shown below:

$$\Delta\mathbf{C} = 2\sqrt{2} \cdot \begin{bmatrix} 0 & 0 & 0 & 0 & 0 & 0 & 0 & 0 \\ s_1 s_2 & s_1 s_4 & s_1 s_6 & s_1 & s_1 s_6 & s_1 s_4 & s_1 s_2 & s_7 \\ s_2 s_4 & s_2 & s_2 s_4 & 0 & -s_2 s_4 & -s_2 & -s_2 s_4 & 0 \\ s_3 s_6 & s_3 s_4 & -s_3 s_2 & -s_3 & -s_3 s_2 & s_3 s_4 & s_3 s_6 & s_5 \\ s_4 & 0 & -s_4 & 0 & s_4 & 0 & -s_4 & 0 \\ s_5 s_6 & -s_5 s_4 & -s_5 s_2 & s_5 & -s_5 s_2 & -s_5 s_4 & s_5 s_6 & s_3 \\ s_6 s_4 & -s_6 & s_6 s_4 & 0 & -s_6 s_4 & s_6 & -s_6 s_4 & 0 \\ s_7 s_2 & -s_7 s_4 & s_7 s_6 & -s_7 & s_7 s_6 & -s_7 s_4 & s_7 s_2 & s_1 \end{bmatrix},$$

for $s_k = \sin(k\pi/16)$, $k = 1, 2, \dots, 7$.

If the input signal possesses null mean, then we have that $X[0] = 0$ and $z[N-1] = 0$. Therefore, the first row and last column of $\Delta\mathbf{C}$ can be neglected. It follows that only the remaining 7×7 submatrix is necessary for the computation of \mathbf{X} . This particular matrix is given by:

$$\tilde{\mathbf{C}} = 2\sqrt{2} \cdot \begin{bmatrix} s_1 s_2 & s_1 s_4 & s_1 s_6 & s_1 & s_1 s_6 & s_1 s_4 & s_1 s_2 \\ s_2 s_4 & s_2 & s_2 s_4 & 0 & -s_2 s_4 & -s_2 & -s_2 s_4 \\ s_3 s_6 & s_3 s_4 & -s_3 s_2 & -s_3 & -s_3 s_2 & s_3 s_4 & s_3 s_6 \\ s_4 & 0 & -s_4 & 0 & s_4 & 0 & -s_4 \\ s_5 s_6 & -s_5 s_4 & -s_5 s_2 & s_5 & -s_5 s_2 & -s_5 s_4 & s_5 s_6 \\ s_6 s_4 & -s_6 & s_6 s_4 & 0 & -s_6 s_4 & s_6 & -s_6 s_4 \\ s_7 s_2 & -s_7 s_4 & s_7 s_6 & -s_7 & s_7 s_6 & -s_7 s_4 & s_7 s_2 \end{bmatrix}.$$

Notice that $\tilde{\mathbf{C}}$ is sufficient for the computation of all DCT coefficients—except the DC level.

3.2 Scaling Matrix

An examination of matrix $\tilde{\mathbf{C}}$ shows repeated multiplicands along its rows. Thus, the following factorization is obtained:

$$\tilde{\mathbf{C}} = \mathbf{S} \cdot \begin{bmatrix} s_2 & s_4 & s_6 & 1 & s_6 & s_4 & s_2 \\ s_4 & 1 & s_4 & 0 & -s_4 & -1 & -s_4 \\ s_6 & s_4 & -s_2 & -1 & -s_2 & s_4 & s_6 \\ 1 & 0 & -1 & 0 & 1 & 0 & -1 \\ s_6 & -s_4 & -s_2 & 1 & -s_2 & -s_4 & s_6 \\ s_4 & -1 & s_4 & 0 & -s_4 & 1 & -s_4 \\ s_2 & -s_4 & s_6 & -1 & s_6 & -s_4 & s_2 \end{bmatrix},$$

where $\mathbf{S} = 2\sqrt{2} \cdot \text{diag}(s_1, s_2, s_3, s_4, s_5, s_6, s_7)$. The above expression tells us that the matrix \mathbf{S} contributes only with scaling factors to the actual DCT computation. When considering applications that require only a scaled version of the DCT—such as harmonic detection [22] and color enhancement [42]—the computational cost of \mathbf{S} can be disregarded. Additionally, in the context of image compression, diagonal matrices can be directly absorbed into the quantization matrix; representing no extra computation [43, 44].

Notice also that the scaling factor $2\sqrt{2}s_4 = 2$ is a trivial multiplication [20] that can be implemented via a

simple bit-shifting operation. Therefore, the computational cost of the scaling matrix \mathbf{S} is actually only six—not seven—multiplications.

3.3 Fast Algorithm

Now our aim is to provide a sparse matrix factorization to $\tilde{\mathbf{C}}$. Because $\tilde{\mathbf{C}}$ is a highly symmetrical matrix, factorization methods based on butterfly structures can be directly applied [1, 2, 20]. Therefore, we obtain the following factorization:

$$\tilde{\mathbf{C}} = \mathbf{S} \cdot \mathbf{P} \cdot \mathbf{M} \cdot \mathbf{A},$$

where

$$\mathbf{P} = \begin{bmatrix} 1 & 0 & 0 & 0 & 0 & 0 & 0 \\ 0 & 0 & 1 & 0 & 0 & 0 & 0 \\ 0 & 0 & 0 & 0 & 1 & 0 & 0 \\ 0 & 0 & 0 & 0 & 0 & 0 & 1 \\ 0 & 1 & 0 & 0 & 0 & 0 & 0 \\ 0 & 0 & 0 & 1 & 0 & 0 & 0 \\ 0 & 0 & 0 & 0 & 0 & 1 & 0 \end{bmatrix},$$

$$\mathbf{A} = \begin{bmatrix} 1 & 0 & 0 & 0 & 0 & 0 & 1 \\ 0 & 1 & 0 & 0 & 0 & 1 & 0 \\ 0 & 0 & 1 & 0 & 1 & 0 & 0 \\ 0 & 0 & 0 & 1 & 0 & 0 & 0 \\ 0 & 0 & 1 & 0 & -1 & 0 & 0 \\ 0 & 1 & 0 & 0 & 0 & -1 & 0 \\ 1 & 0 & 0 & 0 & 0 & 0 & -1 \end{bmatrix},$$

and

$$\mathbf{M} = \begin{bmatrix} s_2 & s_4 & s_6 & 1 & 0 & 0 & 0 \\ s_6 & s_4 & -s_2 & -1 & 0 & 0 & 0 \\ s_6 & -s_4 & -s_2 & 1 & 0 & 0 & 0 \\ s_2 & -s_4 & s_6 & -1 & 0 & 0 & 0 \\ 0 & 0 & 0 & 0 & s_4 & 1 & s_4 \\ 0 & 0 & 0 & 0 & -1 & 0 & 1 \\ 0 & 0 & 0 & 0 & s_4 & -1 & s_4 \end{bmatrix}.$$

Matrix \mathbf{P} is a simple permutation matrix, which represents no computational cost. In terms of hardware, \mathbf{P} translates into simple wiring. Matrix \mathbf{A} is an additive matrix consisting of the usual butterfly stage present in decimation-in-frequency algorithms [20]. The remaining matrix \mathbf{M} is block-diagonal and still contains mathematical redundancies due to its symmetrical nature. Considering the matrix factorizations for fast algorithm design described in [20], the following expression can be obtained:

$$\mathbf{M} = \mathbf{M}_1 \cdot \mathbf{M}_2 \cdot \mathbf{M}_3 \cdot \mathbf{M}_4,$$

where

$$\mathbf{M}_1 = \begin{bmatrix} 1 & 0 & 1 & 0 & 0 & 0 & 0 \\ 0 & 1 & 0 & 1 & 0 & 0 & 0 \\ 0 & 1 & 0 & -1 & 0 & 0 & 0 \\ 1 & 0 & -1 & 0 & 0 & 0 & 0 \\ 0 & 0 & 0 & 0 & 1 & 0 & 0 \\ 0 & 0 & 0 & 0 & 0 & 0 & 1 \\ 0 & 0 & 0 & 0 & 0 & 1 & 0 \end{bmatrix},$$

$$\mathbf{M}_2 = \begin{bmatrix} s_2 & s_6 & 0 & 0 & 0 & 0 & 0 \\ s_6 & -s_2 & 0 & 0 & 0 & 0 & 0 \\ 0 & 0 & 1 & 1 & 0 & 0 & 0 \\ 0 & 0 & 1 & -1 & 0 & 0 & 0 \\ 0 & 0 & 0 & 0 & 1 & 1 & 0 \\ 0 & 0 & 0 & 0 & 1 & -1 & 0 \\ 0 & 0 & 0 & 0 & 0 & 0 & -1 \end{bmatrix},$$

$$\mathbf{M}_3 = \begin{bmatrix} 1 & 0 & 0 & 0 & 0 & 0 & 0 \\ 0 & 0 & 1 & 0 & 0 & 0 & 0 \\ 0 & s_4 & 0 & 0 & 0 & 0 & 0 \\ 0 & 0 & 0 & 1 & 0 & 0 & 0 \\ 0 & 0 & 0 & 0 & s_4 & 0 & 0 \\ 0 & 0 & 0 & 0 & 0 & 1 & 0 \\ 0 & 0 & 0 & 0 & 0 & 0 & 1 \end{bmatrix},$$

$$\mathbf{M}_4 = \begin{bmatrix} 1 & 0 & 0 & 0 & 0 & 0 & 0 \\ 0 & 1 & 0 & 0 & 0 & 0 & 0 \\ 0 & 0 & 1 & 0 & 0 & 0 & 0 \\ 0 & 0 & 0 & 1 & 0 & 0 & 0 \\ 0 & 0 & 0 & 0 & 1 & 0 & 1 \\ 0 & 0 & 0 & 0 & 0 & 1 & 0 \\ 0 & 0 & 0 & 0 & 1 & 0 & -1 \end{bmatrix}.$$

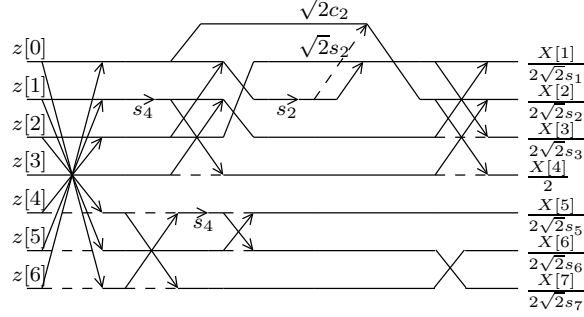

Figure 2: SFG for the proposed algorithm. Dashed lines represents multiplication by -1 .

The block-diagonal matrix \mathbf{M}_2 contains a rotation block $\begin{bmatrix} s_2 & s_6 \\ s_6 & -s_2 \end{bmatrix}$, which can be further decomposed [2]. Thus, we have:

$$\mathbf{M}_2 = \mathbf{R}_1 \cdot \mathbf{R}_2 \cdot \mathbf{R}_3,$$

where

$$\mathbf{R}_1 = \begin{bmatrix} 0 & s_6 - s_2 & 1 & 0 & 0 & 0 & 0 & 0 \\ s_2 + s_6 & 0 & -1 & 0 & 0 & 0 & 0 & 0 \\ 0 & 0 & 0 & 1 & 0 & 0 & 0 & 0 \\ 0 & 0 & 0 & 0 & 1 & 0 & 0 & 0 \\ 0 & 0 & 0 & 0 & 0 & 1 & 0 & 0 \\ 0 & 0 & 0 & 0 & 0 & 0 & 1 & 0 \\ 0 & 0 & 0 & 0 & 0 & 0 & 0 & 1 \end{bmatrix},$$

$$\mathbf{R}_3 = \begin{bmatrix} 1 & 0 & 0 & 0 & 0 & 0 & 0 & 0 \\ 0 & 1 & 0 & 0 & 0 & 0 & 0 & 0 \\ 1 & 1 & 0 & 0 & 0 & 0 & 0 & 0 \\ 0 & 0 & 1 & 1 & 0 & 0 & 0 & 0 \\ 0 & 0 & 1 & -1 & 0 & 0 & 0 & 0 \\ 0 & 0 & 0 & 0 & 1 & 1 & 0 & 0 \\ 0 & 0 & 0 & 0 & 1 & -1 & 0 & 0 \\ 0 & 0 & 0 & 0 & 0 & 0 & -1 & 1 \end{bmatrix},$$

and $\mathbf{R}_2 = \text{diag}(1, 1, s_2, 1, 1, 1, 1, 1)$.

By means of usual trigonometric manipulations, we notice that the required multiplicands in \mathbf{R}_1 satisfy: $s_2 + s_6 = \sqrt{2}c_2$ and $s_6 - s_2 = \sqrt{2}s_2$. Finally, the complete sparse matrix factorization is given by:

$$\tilde{\mathbf{C}} = \mathbf{S} \cdot \mathbf{P} \cdot \mathbf{M}_1 \cdot \mathbf{R}_1 \cdot \mathbf{R}_2 \cdot \mathbf{R}_3 \cdot \mathbf{M}_3 \cdot \mathbf{M}_4 \cdot \mathbf{A}.$$

The signal flow graph (SFG) for the proposed algorithm is shown in Figure 2.

4 Computational Complexity Assessment and Comparison

In this section, we assess the computational complexity of the proposed algorithm as measured by its arithmetic cost. For such, we evaluate the additive and multiplicative count required by the introduced method.

4.1 Results

We distinguish the following scenarios for the input data: (i) arbitrary signal; (ii) null mean signal; (iii) accumulated signal; and (iv) null mean and accumulated signal. Scenario (i) is the most general case. Thus, there is less redundancy to be exploited aiming at the minimization of computational cost. Scenario (i) is commonly found in image compression applications [2, 37]. Scenario (ii) is pertinent in the context of feature detection, for instance, where DC level may not be relevant [33, 34]. Scenario (iii) represents the case where the input signal is natively accumulated (integrated). This situation occurs in face recognition problems, where usual algorithms require data to be integrated [35, 36]. Scenario (iv) is a combination of above last two cases. Notice that Scenario (ii) does not

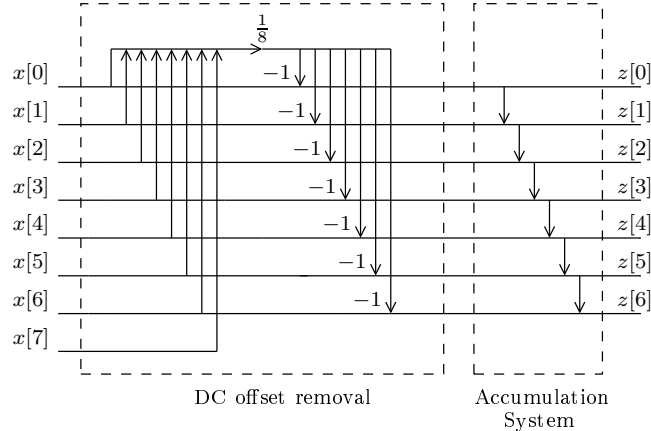

Figure 3: SFG for pre-processing stage consisting of the DC component removal coupled with accumulation system.

require the DC offset removal block (cf. Figure 1); Scenario (iii) does not require the accumulation system but needs a DC removal block; and Scenario (iv) requires neither the DC offset removal block nor the accumulation system.

Table 2 compares the proposed method with several prominent techniques for the 8-point DCT evaluation under all discussed scenarios. The details of the arithmetic complexity assessment of each considered technique is found in [2]. For each scenario, we emphasized in bold the best results. Because Arai method [18] and the proposed algorithm are scaled DCT methods, we show the multiplicative complexity of the non-scaled computation as well. In parenthesis, when applicable, we furnish the full multiplicative complexity of the scaled methods, when the scaling factors are considered. The multiplicative complexity for Loeffler, Lee, and Chen DCT algorithms are limited to the non-scaled case, because these methods do not admit scaled computation. The proposed algorithm could outperform *all* competing method under Scenarios (ii), (iii), and (iv). Although the proposed method requires five multiplications to compute the scaled DCT—the same as the Arai method—it demands fewer scaling multiplications. Scenario (i) is not ideally suitable for the proposed algorithm because it benefits of the DC level removal and accumulated input signal. However, even in this case, the introduced algorithm could achieve the theoretical minimum of multiplicative complexity.

4.2 Discussion

For Scenario (i), the DC offset removal block requires seven additions to compute the mean value and then seven subtractions to remove the DC level from input samples $x[0], x[1], \dots, x[6]$. Thus, a total of 14 additions are necessary. The accumulation system requires a total of six additions (cf. (4)). Thus, the DC removal block combined with accumulation system requires a total of 20 additions. Figure 3 details the inner structure of each of the above-mentioned blocks. Multiplicative costs are concentrated in matrices \mathbf{S} , \mathbf{R}_1 , \mathbf{R}_2 , and \mathbf{M}_3 . They account for 11 non-trivial multiplications, which is the minimum multiplicative complexity for the 8-point DCT [31, 32]. Matrices \mathbf{M}_1 , \mathbf{R}_1 , \mathbf{R}_3 , \mathbf{M}_4 , and \mathbf{A} contribute with 19 additions. Thus, under Scenario (i), the proposed algorithm requires a total of 39 additions. As we demonstrate below, this is the only scenario where the proposed method cannot outperform the most relevant method for the 8-point DCT computation. Nevertheless, even in this scenario, the proposed method attained the theoretical minimal multiplicative complexity, which is a relevant figure of merit [20]. In comparison with competing methods, the extra required computation consists of additions only.

Under Scenario (ii), the proposed algorithm does not demand the DC removal block but only one instantiation of an accumulation system (Figure 3, rightmost subblock). Therefore, a total of 13 additions in savings is attained when compared to Scenario (i). Consequently, considering Scenario (ii), the proposed algorithm requires only 25 additions.

Table 2: Comparison for non-trivial products and additions for 8-point DCT algorithms

Algorithm	Scaled?	Scenarios	Mult.	Additions
Loeffler [16]	No	(i)	11	29
		(ii)	11	26
		(iii)	11	36
		(iv)	11	33
Lee [15]	No	(i)	12	29
		(ii)	11	26
		(iii)	12	36
		(iv)	11	33
Chen <i>et al.</i> [14]	No	(i)	13	26
		(ii)	12	23
		(iii)	13	33
		(iv)	12	30
Arai <i>et al.</i> [18]	Yes	(i)	5 (13)	28
		(ii)	5 (12)	25
		(iii)	5 (13)	35
		(iv)	5 (12)	32
Proposed	Yes	(i)	5 (11)	39
		(ii)	5 (11)	25
		(iii)	5 (11)	30
		(iv)	5 (11)	19

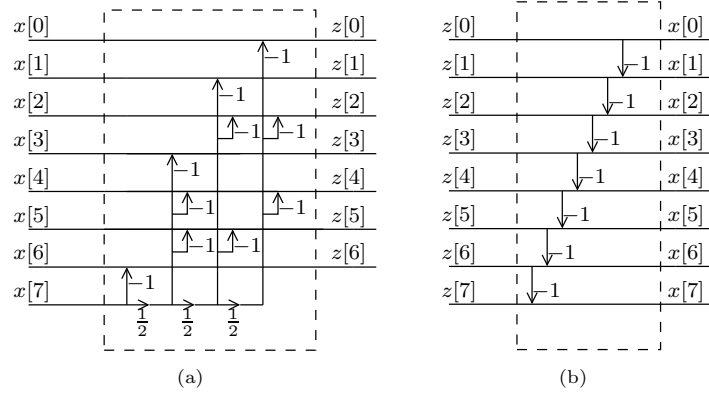

Figure 4: SFG of (a) the DC removal block and (b) the finite difference operator, both for accumulated input signal.

Usual methods presented in literature can be adapted for Scenario (ii). However, when compared to the costs under Scenario (i), such methods could save only three additions, instead of seven additions for the computation of the DC level. This is particularly true for both Loeffler [16] and Lee [15] algorithms which demand the same number of multiplications as the proposed method when exact spectrum is required. Additionally, the proposed algorithm can furnish a scaled version of the DCT spectrum at the same performance required by the Arai algorithm [18].

Under Scenario (iii), the proposed method does not demand the accumulation system, but still requires the DC removal block. In this case, the DC removal block must be adapted to process accumulated input signals. Figure 4(a) shows the modified DC removal block, which requires 10 additions to generate the sought sequence $z[n]$. In contrast, traditional methods for DCT computation when faced with accumulated signals have to pre-process the input data through a difference system. Figure 4(b) shows the SFG for a difference system, which is completely *eliminated* in the proposed algorithm.

Scenario (iv) is a combination of Scenarios (ii) and (iii); being the most appropriate scenario for the proposed method. In this case, the proposed algorithm does not require any pre-processing stage, being the input data directly applicable. Thus, the proposed method is limited the operations described in the architecture shown in Figure 2. Under this scenario, usual methods requires a pre-processing stage consisting of a difference system (Figure 4(b)), which demands seven extra additions.

The proposed algorithm can be extended for different sequence sizes, which can benefit multiple-blocklength encoding methods such as HEVC [12, 2]. Such extension can be derived from (3) assuming an arbitrary length N . Considering the DCT kernel (Table 1) and applying the forward difference operator, we obtain:

$$\Delta \ker[n, k] = 2\alpha_k \sin\left(\frac{k\pi}{2N}\right) \sin\left(\frac{k\pi(n+1)}{N}\right),$$

where α_k is given as in (5) and $n, k = 1, 2, \dots, N-1$. Despite the similarity with the DST kernel, the above expression contains a post-multiplicative factor $2\alpha_k \sin(k\pi/2N)$ that can be separated into a diagonal matrix. Thus the design of the associate fast algorithm becomes equivalent to the problem of factorizing an $(N-1) \times (N-1)$ matrix with entries given by $\sin(k\pi(n+1)/N)$, $n, k = 1, 2, \dots, N-1$. Such factorization can be accomplished by means of the techniques detailed in [20] and the approach described in this paper, where the 8-point DCT is a showcase.

The proposed 1D DCT algorithm can be readily extended to the two dimensional (2D) case, thus being suitable for image processing applications. Indeed, because of DCT kernel separability, the 2D DCT can be computed by successive calls of the 1D DCT. This can be achieved in a two-step procedure: (i) computation of the 1D DCT of each row of a given input image; and (ii) computation of the 1D DCT of each column of the image derived from step (i). The resulting image is the 2D DCT of the original image. Therefore, in principle, any 1D DCT algorithm can be immediately extended to the 2D case without any additional modification [2].

Regarding the DCT computation over 2D domain, different image representation schemes can be employed in order to reduce the overall execution time. The works on [45, 46, 47, 48] consider a different image representation based on slice intensity representation (ISR). Although this representation can be useful for some scenarios such as pattern recognition [49, 50, 51], we attain to the usual image representation adopted by the signal processing community [20, 2, 3].

5 Remarks and Conclusion

In this paper, we proposed a new method for the 8-point DCT computation based on the summation-by-parts formula. A matrix formalism was furnished and its arithmetic complexity was assessed.

The proposed method attained the theoretical multiplicative complexity lower bound for the computation of the *exact* DCT as detailed in [32]. The theoretical minimum is consists of 11 multiplications. *Per se*, achieving the minimum of 11 multiplications is not a trivial task. Not many DCT algorithms are capable of such, being the Loeffler

DCT the most popular method in literature to achieve the minimum [16].

Moreover, the introduced method could also compute the scaled DCT with only *five* multiplications, matching the well-known Arai DCT [18]. Thus the proposed method can simultaneously match both Loeffler and Arai DCT in terms of multiplicative complexity. Not only it could attain the multiplicative complexity minimum, but it could also outperform several competing methods in three different scenarios when we also consider the additive complexity as a secondary comparison metric. In fact, it outperformed several popular DCT algorithms, when the input signal is assumed to possess null mean or/and it is an integrated (accumulated) signal.

The proposed design can be understood as a fundamental mathematical block to be considered for software and hardware realizations. Additionally, the field of integer and approximate transforms can benefit of the proposed scheme [52, 53]. Indeed, the design of extremely low-complexity approximation methods relies on exact algorithms. Therefore, exact, algebraically precise methods can be a useful resource; even when an approximation could be enough [54].

Particularly, the proposed method is an alternative to Arai algorithm [18] for selected scenarios. The suggested method is suitable in the context of feature detection, where DC level may not be relevant [34] as well as in situations where traditional algorithms require data to be integrated, such as in face recognition problems [35, 36]. In future works, we aim at applying the summation-by-parts formula to different transforms at various blocklengths.

Acknowledgements

This work was partially funded by CNPq, CAPES, and FACEPE.

References

- [1] A. V. Oppenheim, R. W. Schaffer, M. T. Yoder, and W. T. Padgett, *Discrete Time Signal Processing*, vol. 1. Upper Saddle River, NJ: Prentice-Hall, Inc., 3rd ed., Aug. 2009. 1, 2, 3, 6
- [2] V. Britanak, P. Yip, and K. R. Rao, *Discrete Cosine and Sine Transforms*. Academic Press, 2007. 1, 2, 3, 6, 7, 8, 10
- [3] N. Ahmed and K. R. Rao, *Orthogonal Transforms for Digital Signal Processing*. New York, NY: Springer-Verlag, 1975. 1, 10
- [4] S. K. Gupta, J. Jain, and R. Pachauri, "Improved noise cancellation in discrete cosine transform domain using adaptive block LMS filter," *International Journal of Engineering Science and Advanced Technology*, vol. 2, pp. 498–502, June 2012. 1
- [5] S. An and C. Wang, "A computation structure for 2-D DCT watermarking," in *52nd IEEE International Midwest Symposium on Circuits and Systems*, pp. 577–580, Aug. 2009. 1
- [6] A. A. Chien and V. Karamcheti, "Moore's law: The first ending and a new beginning," *Computer*, vol. 46, no. 12, pp. 48–53, 2013. 1
- [7] M. R. Wigan and R. Clarke, "Big data's big unintended consequences," *Computer*, vol. 46, no. 6, pp. 46–53, 2013. 1
- [8] L. Ji and L. X. Ming, "New DCT computation algorithm for VLIW architecture," in *6th International Conference on Signal Processing*, vol. 1, pp. 41–44, 2002. 1
- [9] V. Bhaskaran and K. Konstantinides, *Image and Video Compression Standards*. Kluwer Academic Publishers, June 1997. 1
- [10] G. K. Wallace, "The JPEG still picture compression standard," *IEEE Transactions on Consumer Electronics*, vol. 38, pp. xviii–xxxiv, Feb. 1992. 1
- [11] T. Wiegand, G. J. Sullivan, G. Bjontegaard, and A. Luthra, "Overview of the H.264/AVC video coding standard," *IEEE Transactions on Circuit and Systems for Video Technology*, vol. 13, pp. 560–576, July 2003. 1
- [12] M. T. Pourazad, C. Doutre, M. Azimi, and P. Nasiopoulos, "HEVC: The new gold standard for video compression: How does HEVC compare with H.264/AVC?," *IEEE Consumer Electronics Magazine*, vol. 1, pp. 36–46, July 2012. 1, 10
- [13] K. R. Rao, D. N. Kim, and J. J. Hwang, *Video coding standards: AVS China, H.264/MPEG-4 PART 10, HEVC, VP6, DIRAC and VC-1*. Arlington, TX, USA: Springer, 2014. 1
- [14] H. W.-H. Chen, C. Smith, and S. Fralick, "A fast computational algorithm for the discrete cosine transform," *IEEE Transactions on Communications*, vol. 25, pp. 1004–1009, Jan. 2003. 1, 9
- [15] B. Lee, "A new algorithm to compute the discrete cosine transform," *IEEE Transactions on Acoustics, Speech and Signal Processing*, vol. 32, pp. 1243–1245, Dec. 1984. 1, 9, 10

- [16] C. Loeffler, A. Ligtenberg, and G. S. Moschytz, "A practical fast 1-D DCT algorithms with 11 multiplications," in *International Conference on Acoustics, Speech, and Signal Processing*, vol. 2, pp. 988–991, May 1989. 1, 3, 4, 9, 10
- [17] E. Feig and S. Winograd, "Fast algorithms for the discrete cosine transform," *IEEE Transactions on Signal Processing*, vol. 40, pp. 2174–2193, Sept. 1992. 1
- [18] Y. Arai, T. Agui, and M. Nakajima, "A fast DCT-SQ scheme for images," *IEICE Transactions*, vol. E71, pp. 1095–1097, Nov. 1988. 1, 8, 9, 10, 11
- [19] R. W. Hamming, *Digital Filters*. Hertfordshire, UK: Prentice Hall International Ltd., third ed., 1989. 1, 3
- [20] R. E. Blahut, *Fast Algorithms for Digital Signal Processing*. Cambridge University Press, 2010. 1, 5, 6, 8, 10
- [21] X. Limin, X. Weisheng, and Y. Youling, "A fast harmonic detection method based on recursive DFT," in *Electronic Measurement and Instruments, 2007. ICEMI '07. 8th International Conference on*, pp. 3–972, 2007. 1
- [22] E. Zheng, Z. Liu, and L. Ma, "Study on harmonic detection method based on FFT and wavelet transform," in *2nd International Conference on Signal Processing Systems (ICSPS)*, vol. 3, 2010. 1, 5
- [23] R. L. Graham, D. E. Knuth, and O. Patashnik, *Concrete Mathematics*. Reading, MA: Addison-Wesley Publishing Company, 1989. 2, 5
- [24] T. M. Apostol, *Mathematical Analysis*. Reading, MA: Addison-Wesley Publishing Company, 1981. 2
- [25] K. Mattssona and J. Nordstrma, "Summation by parts operators for finite difference approximations of second derivatives," *Journal of Computational Physics*, vol. 199, pp. 503–540, Sept. 2004. 2
- [26] K. Mattsson, "Boundary procedures for summation-by-parts operators," *Journal of Scientific Computing*, vol. 18, pp. 133–153, Feb. 2003. 2
- [27] J. R. Mosig and A. A. Melcon, "The summation-by-parts algorithm - A new efficient technique for the rapid calculation of certain series arising in shielded planar structures," *IEEE Transactions on Microwave Theory and Techniques*, vol. 50, pp. 215–218, Jan. 2002. 2
- [28] G. Boudreaux-Bartels and T. W. Parks, "Discrete Fourier transform using summation by parts," in *IEEE International Conference on Acoustics, Speech, and Signal Processing*, vol. 12, pp. 1827–1830, Apr. 1987. 2
- [29] G. Boudreaux-Bartels, D. W. Tufts, P. Dhir, G. Sadasiv, and G. Fischer, "Analysis of errors in the computation of Fourier coefficients using the arithmetic Fourier transform (AFT) and summation by parts (SBP)," in *IEEE International Conference on Acoustics, Speech, and Signal Processing*, vol. 2, pp. 1011–1014, May 1989. 2
- [30] R. J. Cintra, "Soma por partes para sinais periódicos e transformadas discretas," in *XXX Simpósio Brasileiro de Telecomunicações - SBrT12*, (Brasília, DF), Sept. 2012. 2
- [31] P. Duhamel and H. H'Mida, "New 2^n DCT algorithms suitable for VLSI implementation," in *IEEE International Conference on Acoustics, Speech, and Signal Processing*, vol. 12, pp. 1805–1808, 1987. 2, 8
- [32] M. T. Heideman, *Multiplicative Complexity, Convolution, and the DFT*. New York: Springer-Verlag, 1988. 2, 4, 8, 10
- [33] A. K. Jain, *Fundamentals of Digital Image Processing*. University of California, Davis: Prentice Hall Information and System Sciences Series, 1989. 2, 7
- [34] Y. Wang, C.-S. Chua, and Y.-K. Ho, "Facial feature detection and face recognition from 2D and 3D images," *Pattern Recognition Letters*, vol. 23, no. 10, pp. 1191–1202, 2002. 2, 7, 11
- [35] Elboher and M. Werman, "Efficient and accurate Gaussian image filtering using running sums," in *12th International Conference on Intelligent Systems Design and Applications (ISDA)*, pp. 897–902, 2012. 2, 7, 11
- [36] P. Viola and M. Jones, "Rapid object detection using a boosted cascade of simple features," in *Computer Vision and Pattern Recognition, 2001. CVPR 2001. Proceedings of the 2001 IEEE Computer Society Conference on*, vol. 1, 2001. 2, 7, 11
- [37] R. C. Gonzalez and R. E. Woods, *Digital Image Processing*. Prentice-Hall, Inc., 3 ed., 2007. 2, 7
- [38] H. El-Banna, A. A. El-Fattah, and W. Fakhr, "An efficient implementation of the 1D DCT using FPGA technology," in *Engineering of Computer-Based Systems, 2004. Proceedings. 11th IEEE International Conference and Workshop on the*, pp. 356–360, 2004. 4
- [39] S. J. Shan, C. Chen, and E. Yang, "High performance 2-D IDCT for image/video decoding based on FPGA," in *2012 International Conference on Audio, Language and Image Processing (ICALIP)*, pp. 33–38, 2012. 4
- [40] H. K. C.-K. Fong and W.-K. Cham, "LLM integer cosine transform and its fast algorithm," *IEEE Transactions on Circuits and Systems for Video Technology*, vol. 22, no. 6, pp. 844–854, 2012. 4
- [41] M. Abramowitz and I. A. Stegun, eds., *Handbook of Mathematical Functions: with Formulas, Graphs, and Mathematical Tables*. MIT Press, 1964. 5
- [42] Mukherjee and S. K. Mitra, "Enhancement of color images by scaling the DCT coefficients," *IEEE Transactions on Image Processing*, vol. 17, no. 10, pp. 1783–1794, 2008. 5
- [43] S. Bouguezel, M. O. Ahmad, and M. N. S. Swamy, "A multiplication-free transform for image compression," in *2nd International Conference on Signals, Circuits and Systems*, (Monastir, TN), pp. 1–4, 2008. 5
- [44] V. Dimitrov and K. A. Wahid, "On the error-free computation of fast cosine transform," *Information Theories and Applications*, vol. 12, no. 4, pp. 321–327, 2005. 5

- [45] G. A. Papakostas, D. E. Koulouriotis, and E. G. Karakasis, *Image Processing*, ch. 2, Efficient 2-D DCT Computation from an Image Representation Point of View. INTECH, Sept. 2009. 10
- [46] G. A. Papakostas, E. G. Karakasis, and D. E. Koulouriotis, "Efficient and accurate computation of geometric moments on gray-scale images," *Pattern Recognition*, vol. 41, no. 6, pp. 1895–1904, 2008. 10
- [47] G. A. Papakostas, E. G. Karakasis, and D. E. Koulouriotis, "On accelerating the computation of 2-D discrete cosine transform in image processing," in *International Conference on Signals and Electronic Systems*, pp. 7–10, Sept. 2008. 10
- [48] G. A. Papakostas, E. G. Karakasis, and D. E. Koulouriotis, "Exact and speedy computation of legendre moments on binary images," in *Proceedings of the Eight International Workshop on Image Analysis for Multimedia Interactive Services (WIAMIS)*, (Washington, DC, USA), pp. 48–48, IEEE Computer Society, 2007. 10
- [49] M. Hassaballah, A. A. Abdelmgeid, and H. A. Alshazly, *Image Feature Detectors and Descriptors*, ch. Image Features Detection, Description and Matching, pp. 11–45. Cham: Springer International Publishing, 2016. 10
- [50] M. Sayyouri, A. Hmimid, and H. Qjidaa, "A fast computation of hahn moments for binary and gray-scale images," in *IEEE International Conference on Complex Systems (ICCS)*, pp. 1–6, Nov. 2012. 10
- [51] A. Hmimid, M. Sayyouri, and H. Qjidaa, "A fast method for reconstruction of binary and gray-scale images by the tchebichef moments," in *Colloquium in Information Science and Technology*, pp. 106–111, Oct. 2012. 10
- [52] S. Bouguezel, M. O. Ahmad, and M. N. S. Swamy, "Binary discrete cosine and hartley transforms," *IEEE Transactions on Circuits and Systems I*, vol. 60, pp. 989–1002, Apr. 2013. 11
- [53] S. Bouguezel, M. O. Ahmad, and M. N. S. Swamy, "A low-complexity parametric transform for image compression," in *IEEE International Symposium on Circuits and Systems*, (Rio de Janeiro, BR), pp. 2145–2148, May 2011. 11
- [54] C. J. Tablada, F. M. Bayer, and R. J. Cintra, "A class of DCT approximations based on the Feig-Winograd algorithm," *Signal Processing*, 2015. 11