

# Embedding a $\theta$ -invariant code into a complete one

Jean Néraud, Carla Selmi

*Laboratoire d'Informatique, de Traitement de l'Information et des Systèmes (LITIS), Université de Rouen Normandie, UFR Sciences et Techniques Avenue de l'université, 76830 Saint Etienne du Rouvray, France*

---

## Abstract

Let  $A$  be a finite or countable alphabet and let  $\theta$  be a literal (anti)morphism onto  $A^*$  (by definition, such a correspondence is determined by a permutation of the alphabet). This paper deals with sets which are invariant under  $\theta$  ( $\theta$ -invariant for short). We establish a formula which allows to embed any non-complete  $\theta$ -invariant code into a complete one: this brings a positive answer to the open question that was stated in [11].

*Keywords:* word, equation, code, variable length code, prefix, suffix, regular, maximal, thin, complete, morphism, antimorphism, (anti)morphism, invariant, involutive, idempotent, literal, letter-to-letter

---

## 1. Introduction

In the free monoid theory, during the last decade, research involving one-to-one *morphic* or *antimorphic* correspondences have played a particularly important part: this is due to the powerful applications of these objects, in particular in the framework of DNA-computing. Given a finite or countable *alphabet*, say  $A$ , any such mapping is a substitution which is completely determined by extending a unique permutation of  $A$  onto  $A^*$  (the *free monoid* that is generated by  $A$ ), the resulting mapping being commonly referred to as *literal* (or *letter-to-letter*).

In the special case of involutive morphisms or antimorphisms -we write (anti)morphisms for short, lots of successful investigations were done for extending the now classical combinatorial properties on words. The topics of the so-called pseudo-palindromes [5], that of  $\theta$ -episturmian words [14], and the one of pseudo-repetitions [3, 16] were particularly involved. The framework of some peculiar families of codes [12] and that of equations in words [6, 4, 13, 8] were also concerned. In the family of *involutive* (anti)morphisms, generalizations of the famous theorem of Fine and Wilf [15, Proposition 1.3.5] were also established [7, 9].

Also starting with equations in words, in [11] we initiated a study of sets that are invariant under a given (anti)morphism  $\theta$  ( $\theta$ -invariant sets for short). In particular, we proved that those sets satisfy an extension of the famous Defect theorem (eg [15, Theorem 1.2.5]). We established also that, for any  $\theta$ -invariant code in the large class of the so-called *thin* codes (which contains the *regular* ones), being *maximal* is equivalent to being *complete* [11, Theorem 11]. This last result consists in an extension of a famous result due to Schützenberger [10, Theorem 2.5.16]. As an aside, define a  $\theta$ -code as a set  $X$  such that  $\bigcup_{i \in \mathbb{Z}} \theta^i(X)$  is a code.

---

*Email addresses:* jean.neraud@univ-rouen.fr, neraud.jean@gmail.com (Jean Néraud), carla.selmi@univ-rouen.fr (Carla Selmi)

It is straightforward to prove that, in the family of those  $\theta$ -codes, the maximal members are necessarily  $\theta$ -invariant: this underscores the importance of the notion of  $\theta$ -invariance.

In [11], we also interested in the problem of embedding a non-complete code into a complete one. For the first time, this question was stated in [2], where the author asked whether any finite code can be embedded into a regular one. A positive answer was provided in [1], where was established a formula for embedding any regular code into a complete one. From the point of view of  $\theta$ -invariant codes, in [11, Proposition 12], we obtained a positive answer in the special case where  $\theta$  is an involutive antimorphism different from the so-called mirror image, and we let open the general problem:

*Given a regular non-complete  $\theta$ -invariant code  $X$ , is there a regular complete one that contains  $X$ ?*

In the present paper, by establishing the following result, we bring a positive answer:

**Theorem** *Given a finite alphabet  $A$ , any non-complete regular  $\theta$ -invariant code  $X \subseteq A^*$  may be embedded into a complete regular one.*

As a consequence, we obtain a very shorter alternative proof of [11, Theorem 11].

We now describe the contents of the paper. Section 2 contains the preliminaries: the terminology of the free monoid is settled, and the definitions of some classical notions concerning codes are recalled. The main result is established in Section 3.

## 2. Preliminaries

### 2.1. Words and free monoid

We adopt the notation of the free monoid theory. In the whole paper, we consider a finite or countable alphabet  $A$ , and we denote by  $A^*$  the free monoid that it generates. Given a subset  $X$  of  $A^*$ , we denote by  $X^*$  the submonoid of  $A^*$  that is generated by  $X$ , moreover we set  $X^+ = X^* \setminus \{\varepsilon\}$ . Given a word  $w$ , we denote by  $|w|$  its length, the empty word, which we denote by  $\varepsilon$ , being the word with length 0. We denote by  $w_i$  the letter of position  $i$  in  $w$ : with this notation we have  $w = w_1 \cdots w_{|w|}$ .

Given  $x \in A^*$  and  $w \in A^+$ , we say that  $x$  is a *prefix* (*suffix*) of  $w$  if a word  $u$  exists such that  $w = xu$  ( $w = ux$ ). Similarly,  $x$  is a *factor* of  $w$  if two words  $u, v$  exist such that  $w = uxv$ . Given a non-empty set  $X \subseteq A^*$ , we denote by  $P(X)$  ( $F(X)$ ) the set of the words that are prefix (factor) of some word in  $X$ . Clearly, we have  $X \subseteq P(X) \subseteq F(X)$ . Given a pair of words  $w, w'$ , we say that it *overlaps* if words  $u, v$  exist such that  $uw' = uv$  or  $w'u = vw$ , with  $1 \leq |u| \leq |w| - 1$  and  $1 \leq |v| \leq |w'| - 1$ ; otherwise, the pair is *overlapping-free* (in such a case, if  $w = w'$ , we simply say that  $w$  is overlapping-free).

### 2.2. Variable length codes

It is assumed that the reader has a fundamental understanding with the main concepts of the theory of variable length codes: we only recall some of the main definitions and we suggest, if necessary, that he (she) report to [10]. A set  $X$  is a *variable length code* (a *code* for short) if any equation among the words of  $X$  is trivial, that is, for any pair of sequences of words in  $X$ , namely  $(x_i)_{1 \leq i \leq n}, (y_j)_{1 \leq j \leq p}$ , the equation  $x_1 \cdots x_n = y_1 \cdots y_p$  implies  $n = p$  and  $x_i = y_i$ , for each integer  $i \in [1, n]$ . By definition  $X^*$ , is a *free* submonoid. In the present paper the so-called *prefix* codes play a peculiar part in the proof of the main result: a code  $X \subseteq A^*$  is prefix if  $X \cap XA^+ = \emptyset$ .

A code  $X \subseteq A^*$  is *maximal* if it is not strictly included in another code of  $A^*$ . Given a code  $X$ , it is *complete* if  $A^* = F(X^*)$ ;  $X$  is *thin* if  $A^* \neq F(X)$ . Regular codes are well known examples of thin codes [10, Proposition 2.5.20]. From this point of view, the following result was established by Schützenberger:

**Theorem 2.1.** [10, Theorem 2.5.16] *Let  $X \subseteq A^*$  be a thin code. Then the two following conditions are equivalent:*

- (i)  $X$  is complete.
- (ii)  $X$  is a maximal code.

In the framework of  $\theta$ -invariant codes, Theorem 2.1 admits the following extension:

**Theorem 2.2.** [11, Theorem 9] *Let  $X \subseteq A^*$  be a thin  $\theta$ -invariant code. Then the following conditions are equivalent:*

- (i)  $X$  is complete.
- (ii)  $X$  is a maximal code.
- (iii)  $X$  is maximal in the family of  $\theta$ -invariant codes.

### 2.3. Literal (anti)morphisms

In the whole paper, we consider a mapping  $\theta$  which satisfies each of the three following conditions:

- (a)  $\theta$  is a one-to-one correspondence onto  $A^*$ .
- (b)  $\theta$  is *literal*, that is  $\theta(A) \subseteq A$ .
- (c) Either  $\theta$  is a *morphism* or it is an *antimorphism* (it is an antimorphism if  $\theta(\varepsilon) = \varepsilon$  and  $\theta(xy) = \theta(y)\theta(x)$ , for any pair of words  $x, y$ ); for short in any case we write that  $\theta$  is an *(anti)morphism*.

In the case where  $A$  is a finite set, it is well known that the literal (anti)morphism  $\theta$  is *idempotent* (that is, an integer  $n$  exists such that  $\theta^n = id_{A^*}$ ); in particular, if  $|A| = 2$ , then  $\theta$  is *involution*. In the whole paper, we are interested in the family of sets  $X \subseteq A^*$  that are invariant under the mapping  $\theta$  ( $\theta$ -invariant for short), that is  $\theta(X) = X$ .

**Example 1.** Let  $A = \{a, b, c, d\}$ . Consider the (unique) antimorphism  $\theta$  that is defined by  $\theta(a) = a, \theta(b) = b, \theta(c) = d, \theta(d) = c$ . The mapping  $\theta$  is involutive, moreover the sets  $\{aba\}$  and  $\{abcd, cdba\}$  are  $\theta$ -invariant.

**Remark 1.** In the spirit of the families of codes that were introduced in [12], given an (anti)morphism  $\theta$ , define a  $\theta$ -code as a set  $X$  such that  $\bigcup_{i \in \mathbb{Z}} \theta^i(X)$  is a code. Clearly, with this definition any  $\theta$ -code is a code; moreover any  $\theta$ -code that is a maximal code, is necessarily  $\theta$ -invariant. Indeed, if  $X$  is not  $\theta$ -invariant, then we have  $X \subsetneq X \cup \theta(X)$ , thus  $X$  is strictly included in the code  $\bigcup_{i \in \mathbb{Z}} \theta^i(X)$ .

A similar argument proves that if  $X$  is maximal as a  $\theta$ -code, then it is  $\theta$ -invariant (indeed,  $\bigcup_{i \in \mathbb{Z}} \theta^i(X)$  itself is a  $\theta$ -code).

Taking account of the fundamental importance of the concept of maximality in the theory of codes, such properties reinforces the relevance of the notion of  $\theta$ -invariant code.

### 3. Embedding a regular invariant code into a complete one

In this section, we address to the problem of embedding an invariant code into a complete one. Historically, such a question appears for the first time in [2], where the author asked for the possibility of embedding a finite code into a complete regular code. A positive answer was given in [1], where the authors provided a regularity preserving method.

Presently, we consider a non-complete regular  $\theta$ -invariant code  $X$  and we ask for a complete regular  $\theta$ -invariant code  $Y$  such that  $X \subseteq Y$ . In a special case of involutive antimorphisms, in [11, Proposition 12] we gave a method of embedding; however, in the general case of literal (anti)morphisms, the problem remained open.

In the present paper, we will bring a positive answer. Let's begin by describing our construction.

#### 3.1. Some notation

Let  $X$  be a non-complete  $\theta$ -invariant code, and let  $y \notin F(X^*)$ . Necessarily, we have  $|A| \geq 2$  (otherwise,  $X$  would be complete). Without loss of generality, we may assume that the initial and the terminal letters of  $y$  are different (otherwise, substitute to  $y$  the word  $ay\bar{a}$ , with  $a, \bar{a} \in A$  and  $a \neq \bar{a}$ ): in particular, we have  $|y| \geq 2$ . Set:

$$z = \bar{a}^{|y|} y a^{|y|} \quad (y \in aA^*\bar{a}). \quad (1)$$

Since  $\theta$  is a literal (anti)morphism, for each integer  $i \in \mathbb{Z}$ , two different letters  $b, \bar{b}$  exist such that the following property holds:

$$\theta^i(z) = \bar{b}^{|y|} \theta^i(y) b^{|y|}. \quad (2)$$

Finally, we introduce the three following sets:

$$Z = \bigcup_{i \in \mathbb{Z}} \{\theta^i(z)\}, \quad (3)$$

$$W = ZA^* \cap A^*Z, \quad (4)$$

$$T = W \setminus (W \cup X)(W \cup X)^+. \quad (5)$$

By construction, the following inclusion holds:

$$W \subseteq (X \cup T)^+. \quad (6)$$

#### 3.2. Basic properties of $Z$

By construction, each element of the preceding set  $Z$  has length  $3|y|$ . The following statement summarizes the results of [11, Lemma 6, Lemma 7, Corollary 8]:

**Lemma 3.1.** *With the preceding notation each of the three following conditions holds:*

- (i) *Let  $u, v \in A^+$  such that  $uZ \cap Zv \neq \emptyset$ , with  $|u| \leq |z| - 1$ . Then we have  $|u| = |v| \geq 2|y|$ .*
- (ii) *We have  $A^+ZA^+ \cap ZX^*Z = \emptyset$ .*
- (iii) *The set  $X^*Z$  is a prefix code.*

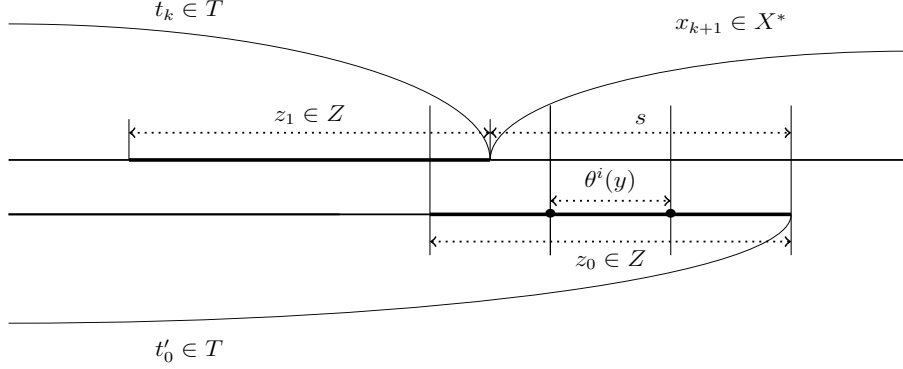

Figure 1: Proof of Lemma 3.2 - the case where  $s \in P(x_{k+1})$ .

### 3.3. The consequences for the set $X \cup T$

**Lemma 3.2.** *The set  $X \cup T$  is a  $\theta$ -invariant code.*

**Proof of Lemma 3.2.** The fact that  $X \cup T$  is  $\theta$ -invariant comes from its construction. For proving that it is a code, we consider an arbitrary equation among the words in  $X \cup T$ . Since  $X$  is a code, and since  $z \notin F(X^*)$ , we may assume that at least one occurrence of a word in  $T$  appears in each side of the equation, therefore this equation takes the following form:

$$x_0 t_0 x_1 t_1 \cdots t_{n-1} x_n = x'_0 t'_0 \cdots t'_{p-1} x_p, \quad (7)$$

with  $x_i, x'_j \in X^*$  ( $0 \leq i \leq n$ ,  $0 \leq j \leq p$ ) and  $t_i, t'_j \in T$  ( $0 \leq i \leq n-1$ ,  $0 \leq j \leq p-1$ ). Since by construction we have  $T \subseteq W \subseteq ZA^*$ , each side of the equation contains a word in  $X^*Z$  as a prefix: according to Property (iii) of Lemma 3.1, this implies  $x_0 = x'_0$ , therefore our equation is equivalent to:

$$t_0 x_1 t_1 \cdots t_{n-1} x_n = t'_0 \cdots t'_{p-1} x_p. \quad (8)$$

Without loss of generality, we assume that  $|t_0| \leq |t'_0|$ ; let  $k$  be the greatest non-negative integer such that a word  $s$  exists with  $t_0 x_1 t_1 \cdots x_k t_k s = t'_0$ , with  $s \in A^*$ . By contradiction, we assume  $s \neq \varepsilon$ . Let  $z_0 \in Z$  ( $z_1 \in Z$ ) be the unique word such that  $t'_0 \in A^* z_0$  ( $t_k \in A^* z_1$ ). According to the preceding property (2), an integer  $i \in \mathbb{Z}$  and two letters  $b, \bar{b}$  exist such that  $z_0 = \bar{b}^{|y|} \theta^i(y) b^{|y|}$ . Moreover, since we have  $y \notin F(X^*)$ , and since  $X$  is  $\theta$ -invariant, we have  $\theta^i(y) \notin F(X^*)$ . By construction, the set with elements  $t_0 x_1 \cdots t_k x_{k+1}$  and  $t'_0$  cannot be a prefix code; more precisely, exactly one of the two following main conditions holds:

1. At first, we assume that  $t'_0 \in P(t_0 x_1 \cdots t_k x_{k+1})$ , that is  $s \in P(x_{k+1})$  (cf Figure 1). By construction, at least one of the two words  $s, z_0$  is a suffix of the other one. Actually, since we have  $z_0 \notin F(X^*)$ , necessarily  $s$  is a proper suffix of  $z_0$ , therefore  $(z_1, z_0)$  is an overlapping pair of words. According to Property (i) of Lemma 3.1, necessarily we have  $|s| \geq 2|y|$ , which implies  $\theta^i(y) \in F(s)$ : a contradiction with  $\theta^i(y) \notin F(X^*)$ .
2. Now, we assume that  $t_0 x_1 \cdots t_k x_{k+1}$  is a proper prefix of  $t'_0$ , thus we have  $s = x_{k+1} s_1$ , with  $s_1 \neq \varepsilon$ . Let  $z_2 \in Z$  be the unique word such that  $t_{k+1} \in z_2 A^*$ . By construction the set with elements  $t_0 x_1 \cdots t_k x_{k+1} z_2$  and  $t'_0$  cannot be a prefix code. More precisely, exactly one of the two following cases occurs:

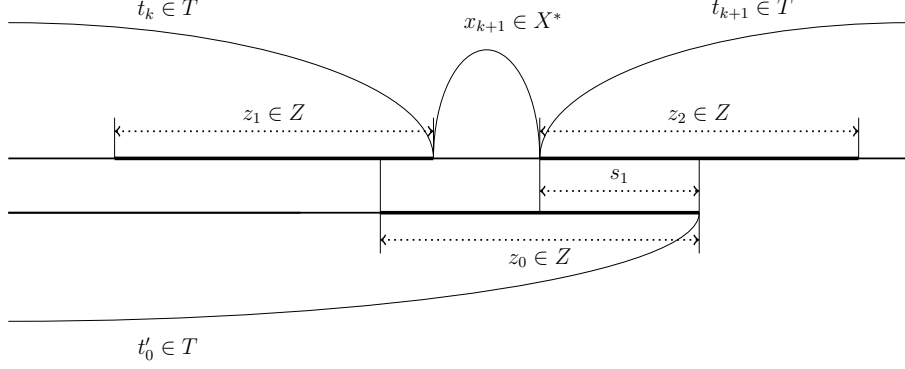

Figure 2: Proof of Lemma 3.2 -the case where  $x_{k+1} \in P(s)$  and  $s_1 \in P(z_2) \setminus \{z_2\}$ .

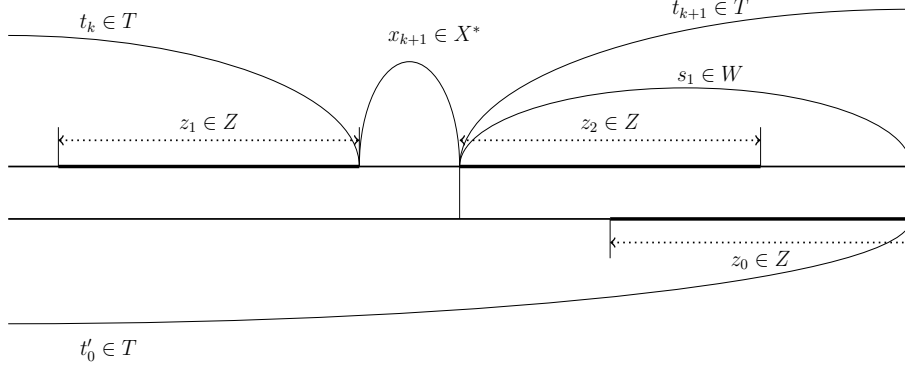

Figure 3: The case where  $x_{k+1} \in P(S)$ , with  $z_2 \in P(s_1)$  in the proof of Lemma 3.2.

- 2.1 The first case corresponds to  $t'_0$  being a proper prefix of  $t_0x_1 \cdots t_kx_{k+1}z_2$ , that is  $s_1$  being a proper prefix of  $z_2$  (cf Figure 2). With this condition, the word  $z_0$  is necessarily a factor of  $z_1x_{k+1}z_2$ . According to Property (ii) of Lemma 3.1, since we have  $s_1 \neq \varepsilon$ , this implies  $z_1 = z_0$ : this contradicts  $s \neq \varepsilon$ .
- 2.2 It remains to consider the case where  $z_2$  is a prefix of  $s_1$  (cf Figure 3). Actually, since  $t_0x_1 \cdots t_kx_{k+1}z_2$  is a prefix of  $t_0x_1 \cdots t_kx_{k+1}s_1 = t'_0$ , with  $|z_2| = |z_0|$ , necessarily  $z_0$  is a suffix of  $s_1$ : we obtain  $s_1 \in z_2A^* \cap A^*z_0$  thus, according to (4),  $s_1 \in W$ . We obtain  $t'_0 = t_0x_1 \cdots t_kx_{k+1}s_1 \in (TX^*)^+W$ , thus  $t'_0 \in (T \cup X)^+W$ : this contradicts (5).

In each case we obtain a contradiction: as a consequence we have  $s = \varepsilon$ , thus  $t'_0 = t_0x_1 \cdots x_k t_k$ . Once more according to (5), it follows from  $t'_0 \in T$  that we have  $k = 0$ , thus  $t'_0 = t_0$ . As a consequence, Equation (8) is equivalent to the following one:

$$x_1 t_1 \cdots t_{n-1} x_n = x'_1 \cdots t'_{p-1} x_p. \quad (9)$$

By iterating these arguments, we shall obtain:  $n = p$  and  $x_i = x'_i, t'_j = t_j$  ( $0 \leq i \leq n, 0 \leq j \leq n-1$ ), therefore  $X \cup T$  is a code: this completes the proof of Lemma 3.2. ■

**Lemma 3.3.** *The code  $X \cup T$  is complete.*

**Proof of Lemma 3.3.** Let  $w \in A^*$ . According to the construction of  $W$  we have  $ZwZ \subseteq W$ . According to (6) this implies  $ZwZ \subseteq (X \cup T)^*$ , therefore we have  $w \in F(X^*)$ . ■

Notice that, in the case where  $A$  is a finite alphabet, by starting with  $y \notin F(X^*)$ , the construction in (3) leads to a finite set  $Z$ : this guarantees the regularity of the sets  $W$  and  $T$ . As a direct consequence, we obtain the following result:

**Theorem 3.4.** *Given a countable (finite) alphabet  $A$ , any non-complete (regular)  $\theta$ -invariant code may be embedded into a complete (regular)  $\theta$ -invariant code.*

**Remark 2.** According to the result of Theorem 3.4, we can draw an alternative proof of Theorem 2.2. Indeed, given a non-complete  $\theta$ -invariant code  $X$ , the existence of a complete  $\theta$ -invariant code strictly containing  $X$  is guaranteed, thus  $X$  is not maximal in the family of  $\theta$ -invariant codes. In other words, in the statement of Theorem 2.2, Property (iii) implies Property (i).

## References

- [1] Ehrenfeucht A. and Rozenberg S. Each regular code is included in a regular maximal one. *Theor. Inform. Appl.*, 20:89–96, 1985.
- [2] Restivo A. On codes having no finite completion. *Discr. Math.*, 17:309–316, 1977.
- [3] Annal Deva Priya Darshini C., Rajkumar Dare V., Venkat I., and K.G. Subramanian. Factors of words under an involution. *J. of Math. and Inf.*, 1:52–59, 2013–2014.
- [4] Day J. D., Fleishmann P., Manea F., and D. Nowotka. Equations enforcing repetitions under permutations. In S. Brlek, F. Dolce, C. Reutenauer, and E. Vandomme, editors, *Combinatorics on Words*, volume 10432, pages 72–84. Lect. Notes in Comp. Sci., sept 2017.
- [5] de Luca A. and De Luca A. Pseudopalindrome closure operators in free monoids. *Theoret. Comp. Sci.*, 362:282–300, 2006.
- [6] Czeizler E., Czeizler E., Kari L., and S. Seki. An extension of the Lyndon-Schützenberger result to pseudoperiodic words. *Inf. Comput.*, 209:717–730, 2011.
- [7] Czeizler E., Kari L., and S. Seki. On a special class of primitive words. *Theoret. Comp. Sci.*, 411:617–630, 2010.
- [8] Manea F., Müller M., Nowotka D., and S. Seki. Generalised Lyndon-Schützenberger equations. In E. Csuhaj-Varú, M. Dietzfelbinger, and Z. Ésik, editors, *Acts of Mathematical Foundations of Computer Science 2014 (MFCS 2014)*, volume 8634, pages 402–413. Lect. Notes in Comp. Sci., 2014.
- [9] Manea F., Mercas R., and Nowotka D. Fine and Wilf’ theorem and pseudo-repetitions. In B. Rován, V. Sassone, and P. Widmayer, editors, *Acts of Mathematical Foundations of Computer Science 2012 (MFCS 2012)*, volume 7464, pages 668–680. Lect. Notes in Comp. Sci., 2012.
- [10] Berstel J., Perrin D., and C. Reutenauer. *Codes and Automata*. Cambridge University Press, 2010.
- [11] Néraud J. and Selmi C. Invariance: a theoretical approach for coding sets of words modulo literal (anti)morphisms. In S. Brlek, F. Dolce, C. Reutenauer, and E. Vandomme, editors, *Combinatorics on Words*, volume 10432, pages 214–227. Lect. Notes in Comp. Sci., sept 2017.
- [12] Kari L. and Mahalingam K. Dna codes and their properties. In C. Mao and T. Yokomori, editors, *12th International Meeting on DNA Computing (DNA12), Revised Selected Papers*, volume 4287, pages 127–142. Lect. Notes in Comp. Sci., june 2006.
- [13] Kari L. and Mahalingam K. Watson-Crick conjugate and commutative words. In M.H. Garzon and H. Yan, editors, *13th International Meeting on DNA Computing (DNA13)*, volume 4848, pages 273–283. Lect. Notes in Comp. Sci., 2008.
- [14] Bucci M., de Luca A., De Luca A., and L. Q. Zamboni. On  $\theta$ -episturmian words. *Eur. J. of Comb.*, 30:473–479, 2009.
- [15] Lothaire M. *Combinatorics on Words*. Cambridge University Press, (2nd edition Cambridge University Press 1997), 1983.
- [16] Gawrychowski P., Manea F., Mercas R., Nowotka D., and C. Tisceanu. Finding pseudo-repetitions. In *30th International Symposium on Theoretical Aspects of Computer Science (STACS 2013)*, pages 257–26.