

Increasing Availability in Distributed Storage Systems via Clustering

Saeid Sahraei, *Student Member, IEEE*, and Michael Gastpar, *Fellow, IEEE*

Abstract

We introduce the Fixed Cluster Repair System (FCRS) as a novel architecture for Distributed Storage Systems (DSS) that achieves a small repair bandwidth while guaranteeing a high availability. Specifically we partition the set of servers in a DSS into s clusters and allow a failed server to choose any cluster other than its own as its repair group. Thereby, we guarantee an availability of $s - 1$. We characterize the repair bandwidth vs. storage trade-off for the FCRS under functional repair and show that the minimum repair bandwidth can be improved by an asymptotic multiplicative factor of $2/3$ compared to the state of the art coding techniques that guarantee the same availability. We further introduce cubic codes designed to minimize the repair bandwidth of the FCRS under the exact repair model. We prove an asymptotic multiplicative improvement of 0.79 in the minimum repair bandwidth compared to the existing exact repair coding techniques that achieve the same availability. In addition, we show that cubic codes are information-theoretically optimal for the FCRS with 2 and 3 complete clusters.

I. INTRODUCTION

A Distributed Storage System (DSS) is a network consisting of several servers that collectively store a large content. A DSS is designed with two main criteria in mind. Firstly, as individual servers can fail at any given time, the data must be stored in a redundant manner. The objective is to avoid a permanent loss of the data even in the event of multiple simultaneous failures. Secondly, these failed servers must be replaced with new ones efficiently, that is, without generating too much traffic. The abstract model that is commonly used to capture these two aspects is as follows. Suppose we have a file \mathcal{M} of size M and n servers each with a storage of size α . We require that any set of k servers can collectively recover the file \mathcal{M} . This is referred to as the data recovery criterion. Put differently, the network must be resilient to failure of any set of $n - k$ servers. As a server fails, a newcomer must replace it, by connecting to d other servers and downloading β units of data from each, thus occupying a repair bandwidth of $\gamma = d\beta$. This is called the repair process and the set of d servers are called the repair group. The definition of repair can be rather ambiguous as there are several different repair models studied in the literature. We are interested in two of them here. “Exact repair”, where the newcomer must be identical to the failed server; and “functional repair” where the newcomer has the same functionality as the failed server, meaning that it must be able to participate in future data recovery and repair processes of other servers. These definitions will be made more precise in the following sections.

Assuming that a failed server must be able to choose *any* set of d servers as its repair group, the trade-off between α and γ has been completely characterized in [1] under functional repair via a network information flow analysis. Two points on this trade-off are of particular interest: the Minimum Bandwidth Regenerating (MBR) point and the Minimum Storage Regenerating (MSR) point where γ and α are minimized, respectively. As for the exact repair model, explicit codes [2]–[5] and converse bounds [6], [7] have been studied in depth. It is known [8] that a non-vanishing gap exists between the overall achievable (α, γ) region for the two repair models.

It was observed in [1] that as the size of the repair group, the parameter d , grows large the required repair bandwidth γ can be made smaller for a fixed storage size α . Setting $d = n - 1$, we achieve the best tradeoff between α and γ . However there are important downfalls to setting d very large. A coding scheme

This work was supported in part by the Swiss National Science Foundation under Grant 169294.

S. Sahraei and M. Gastpar are with the school of Computer and Communication Sciences, École Polytechnique Fédérale de Lausanne, Lausanne 1015, Switzerland (email: saeid.sahraei@epfl.ch; michael.gastpar@epfl.ch).

that is designed based on say, $d = n - 1$ is not optimal for repairing multiple parallel failures. Furthermore, the servers involved in the repair process of one failed server may not be available to perform other tasks. More specifically, an architecture with large d is not suitable for applications that involve reading hot data [9], [10] where multiple parallel reads of the same block might become necessary. Mainly in light of this latter issue, the parameter *availability* is defined in the literature. A server in a DSS is said to have (all-symbol) availability $s - 1$ if there are $s - 1$ disjoint sets of servers that can serve as its repair group. A DSS has availability $s - 1$ if all the servers in the DSS have availability $s - 1$.

This parameter has been largely investigated in the context of locally repairable codes [11], [12], i.e. codes for which the size of the repair group can be made much smaller than k . The tradeoff between locality (size of the repair group) and availability has been extensively studied [9], [10], [13]–[15]. Nevertheless, in the context of locally repairable codes the parameter repair bandwidth is typically ignored (and sacrificed).

In this work we introduce the Fixed Cluster Repair System (FCRS) model as a novel architecture which aims at achieving a high availability while maintaining a low repair bandwidth. The main idea is to partition the servers into s clusters of equal size, and a final cluster of size $s_0 = n \bmod s$. As a server in a cluster fails, we allow it to choose any of the remaining clusters as its repair group (the last cluster is an exception: as it does not contain as many servers as the remaining clusters, we exempt it from serving as a repair group.) This way, we achieve an availability of $s - 1$. It is noteworthy that this clustering is not relevant for the data recovery process, meaning that any set of k servers must be able to recover the file, regardless of which cluster they belong to.

The term Fixed Cluster Repair System has been specifically chosen to contrast with Adjustable Cluster Repair System (ACRS), a general model where the repair groups of two different servers do not necessarily coincide with each other. Studying an ACRS should lead us to answering a general question. Suppose we are given a DSS consisting of n servers that follow the data recovery and repair requirements discussed above, while guaranteeing an availability $s - 1$. What is the trade-off between storage α and repair bandwidth γ under these constraints? To the best of our knowledge there has not been any literature so far that specifically addresses this question. However, the random linear codes as well as the explicit codes for the seminal work in [1] serve as achievability results for ACRS. In fact, since a server can choose *any* subset of d servers as its repair group in [1] where $d \in [k : n]$, it is possible to achieve an availability of $s - 1$ for any $s - 1 \in [1 : \lfloor \frac{n-1}{k} \rfloor]$. The random linear codes and the cubic codes designed for FCRS (Sections III and IV) can be viewed as achievability schemes for ACRS too for any availability $s - 1 \in [1 : \lfloor \frac{n}{k} \rfloor - 1]$. While we emphasize that a comparison with the work in [1] is not in its entirety fair as the parameter availability has not been a driving motive there, we do find it instructive to demonstrate, through a comparative study, how clustering can help with achieving a low repair bandwidth and a high availability.

Our main objective in this paper is to thoroughly analyze the FCRS under both functional and exact repair models. We will follow a network information flow analysis to completely characterize the α vs γ trade-off for the FCRS with arbitrary parameters. An interesting observation is made here. We show that the only adverse affect of increasing the number of clusters in the FCRS is the inevitable decrease in the size of the repair groups. In other words, two FCRSs with $n = ds$ and $n' = ds'$ with respectively s and s' clusters have exactly the same performance in terms of the achievable (α, γ) region. By characterizing the entire (α, γ) region, we show that for small values of γ FCRS performs better than [1]. Whereas, on the other end of the spectrum, when α is small, [1] is superior. The improvements offered by the FCRS are most visible at the MBR point itself (the point where the repair bandwidth is minimized), at which we prove an asymptotic multiplicative improvement of $\frac{2}{3}$ over the repair bandwidth compared to [1], as s , k and n grow large.

Our second contribution is to propose cubic codes for the FCRS which are designed to minimize the repair bandwidth under exact repair. Cubic codes are examples of Fractional Repetition codes [16], codes that do not require any computation to perform the repair process. More specifically, they are subclasses of Affine Resolvable Designs and generalisations of Grid Codes both discussed in [17]. When the number of clusters is small (two or three complete clusters with no residual servers), we prove that cubic codes

do minimize the repair bandwidth for the FCRS. While we do not generalize this proof of optimality of cubic codes to an arbitrary number of clusters, we prove that they achieve an asymptotic (again, as s , k and n grow large) multiplicative improvement of 0.79 over the repair bandwidth compared to the MBR codes for [1].

Before we move on, it is worth noting that clustering is not a new term or technique in the analysis of Distributed Storage Systems. ‘‘Clustered Storage Systems’’ have been studied in a series of works [18], [19] where different repair bandwidths are associated to inter-cluster and intra-cluster repair. These models have close connections with the ‘‘rack model’’ [20]–[22] and are generally motivated by the physical architecture of the network and the fact that the cables/channels which connect the servers within one cluster or rack have higher capacities than the inter-cluster counterparts, which creates the motivation to mostly confine the repair process to within the same cluster as the failed server. They also have slightly different data recovery requirements in [18] than [1] and the model studied here. These physical considerations do not play any role in our analysis. We simply assume a completely symmetric structure where the communication bandwidth between any pair of servers is identical.

The rest of the paper is organized as follows. In Section II we provide a precise description of FCRS. In Section III we analyze the FCRS with arbitrary parameters under the functional repair model and make a numerical as well as analytical comparison with the results in [1]. In section IV we introduce cubic codes as explicit constructions targeted to minimize the repair bandwidth for the FCRS under exact repair. Comparisons with MBR codes for [1] will follow. Finally in Section V, we provide a converse bound for the exact repair problem with $s \leq 3$ complete clusters (no residual servers) which indicates that cubic codes indeed minimize the repair bandwidth when the number of clusters is small.

II. MODEL DESCRIPTION

The FCRS is defined by three parameters n , k and s . Suppose the network consists of $n = ds + s_0$ servers where $d = \lfloor \frac{n}{s} \rfloor$ and $s_0 = n \bmod (n, s)$ and $2 \leq s \leq \lfloor \frac{n}{k} \rfloor$. We partition these servers into $s + 1$ clusters, s of which are of size d and the last of size s_0 . We have a file \mathcal{M} of size $H(\mathcal{M}) = M$. Each server $i \in [1 : n]$ is equipped with a memory. We model each memory with a random variable where the server can store a function of \mathcal{M} . Specifically the random variable $X_{j,t}^{(i)}$ represents the content of the j 'th server in the i 'th cluster at time slot t where $(i, j) \in \{[1 : s] \times [1 : d]\} \cup \{[s + 1] \times [1 : s_0]\}$ and $t \in \mathbb{Z}^+ \cup \{0\}$. We restrict the size of each memory to be bounded by α , that is, $H(X_{j,t}^{(i)}) \leq \alpha \forall i, j, t$. For a set $E \subseteq [1 : d]$ we define $X_{E,t}^{(i)} = \{X_{e,t}^{(i)} \text{ s.t. } e \in E\}$. The initial contents of the servers at $t = 0$ must be chosen in such a way that any set of k servers can collectively decode the file \mathcal{M} , irrespective of their clusters. In other words, for any $(E_1, \dots, E_s, E_{s+1})$ that satisfy $E_i \subseteq [1 : d]$ for $i \in [1 : s]$ and $E_{s+1} \subseteq [1 : s_0]$, and $\sum_{i=1}^{s+1} |E_i| = k$, we must have

$$H(\mathcal{M} | X_{E_1,0}^{(1)}, \dots, X_{E_{s+1},0}^{(s+1)}) = 0.$$

The servers in the network are subject to failure. We assume that at the end of each time slot exactly one server fails. Suppose at the end of time slot t , the ℓ 'th server in the r 'th cluster fails. At the beginning of the next time slot this server is replaced by a newcomer. A second cluster i will be chosen *arbitrarily* such that $i \neq r$. We refer to this as the repair group. The j 'th server in the repair group transmits $Y_{\ell,j,t}^{(r,i)}$, a function of $X_{j,t}^{(i)}$ to the newcomer. We limit the size of this message to satisfy $H(Y_{\ell,j,t}^{(r,i)}) \leq \beta$. Upon receiving these d messages the newcomer stores $X_{\ell,t+1}^{(r)}$ a function of $Y_{\ell,[1:d],t}^{(r,i)}$. Therefore, $H(X_{\ell,t+1}^{(r)} | Y_{\ell,[1:d],t}^{(r,i)}) = 0$. We refer to this process as one round of failure and repair. Due to this requirement, we can assume without loss of generality that $\alpha \leq d\beta$. Note that if $(i, j) \neq (\ell, r)$ then $X_{j,t+1}^{(i)} = X_{j,t}^{(i)}$. In other words, apart from the failed server, the remaining servers remain unchanged at time slot t . We will study two different repair models, both of which have been widely studied in the literature.

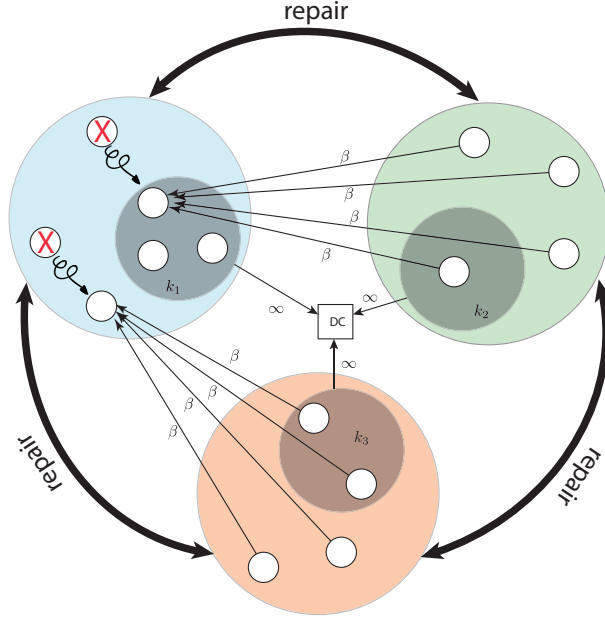

Fig. 1. The FCRS with three complete clusters. Two nodes in the blue cluster fail which are repaired by the red and green clusters respectively. A data collector (DC) is connected to $k = k_1 + k_2 + k_3$ servers, one of which is newcomers.

- *Exact repair*: Under the exact repair model the content of the newcomer must be identical to the failed server. Therefore, we must have

$$X_{j,t}^{(i)} = X_{j,t+1}^{(i)} \quad \forall t, i, j.$$

while studying this model we may omit the subscript t for simplicity and write $X_{j,t}^{(i)} = X_j^{(i)}$.

- *Functional repair*: Under the functional repair model the newcomer may not be identical to the failed server but it must satisfy the data recovery requirement. That is, for any (E_1, \dots, E_{s+1}) that satisfy $E_i \subseteq [1 : d]$ for $i \in [1 : s]$ and $E_{s+1} \subseteq [1 : s_0]$ and $\sum_{i=1}^{s+1} |E_i| = k$, we must have

$$H(\mathcal{M} | X_{E_1,t}^{(1)}, \dots, X_{E_{s+1},t}^{(s)}) = 0, \quad \forall t \geq 0.$$

The model described above is what we refer to as Fixed Cluster Repair System (FCRS). See Figure 1 for an illustration of an FCRS with three complete clusters and no residual servers ($s_0 = 0$). By contrast, a general DSS (what we referred to as ACRS in the introduction) lacks many of these constraints. A DSS with parameters (n, k) consists of n servers $\{X_1, \dots, X_n\}$ such that any k servers can recover the file \mathcal{M} . A DSS is said to have availability $s - 1$ if for each server X_i there are $s - 1$ disjoint sets of servers of respective sizes $d_1^{(i)}, \dots, d_{s-1}^{(i)}$ that can serve as its repair group while generating repair bandwidths $d_1^{(i)} \beta_1^{(i)}, \dots, d_{s-1}^{(i)} \beta_{s-1}^{(i)}$, respectively. The repair process can be defined either as functional or exact repair. The repair bandwidth is defined as

$$\gamma = \max_{i \in [1:n], j \in [1:s-1]} d_j^{(i)} \beta_j^{(i)}. \quad (1)$$

III. THE FUNCTIONAL REPAIR MODEL

In this section, we present a network information flow analysis for the FCRS. Each server $X_{j,t}^{(i)}$ is modelled by a pair of nodes $X_{j,t,in}^{(i)}$ and $X_{j,t,out}^{(i)}$ that are connected with an edge. The source is directly connected to the nodes $X_{j,0,in}^{(i)}$ with edges of infinite capacity. The nodes $X_{j,0,in}^{(i)}$ are in turn connected to $X_{j,0,out}^{(i)}$ with edges of capacity α . Suppose at the end of time slot $t - 1$ (where $t \geq 1$) the j 'th server from the i 'th cluster fails. Assume the newcomer replacing this server is repaired by connecting to the

r 'th cluster. We represent this by d edges which connect $X_{[1:d],t-1,out}^{(r)}$ to $X_{j,t,in}^{(i)}$. Each of these edges has a capacity of β . Furthermore, there will be an edge of capacity α from $X_{j,t,in}^{(i)}$ to $X_{j,t,out}^{(i)}$. Since we have only one failure per time slot, for all other $(i',j') \neq (i,j)$ there will be edges of infinite capacity from $X_{j',t-1,out}^{(i')}$ to $X_{j',t,in}^{(i')}$ and from $X_{j',t,in}^{(i')}$ to $X_{j',t,out}^{(i')}$. At any given time a data collector can be connected to the out nodes of any set of servers of size k with edges of infinite capacity. An illustration has been provided in Figure 2 which involves three clusters.

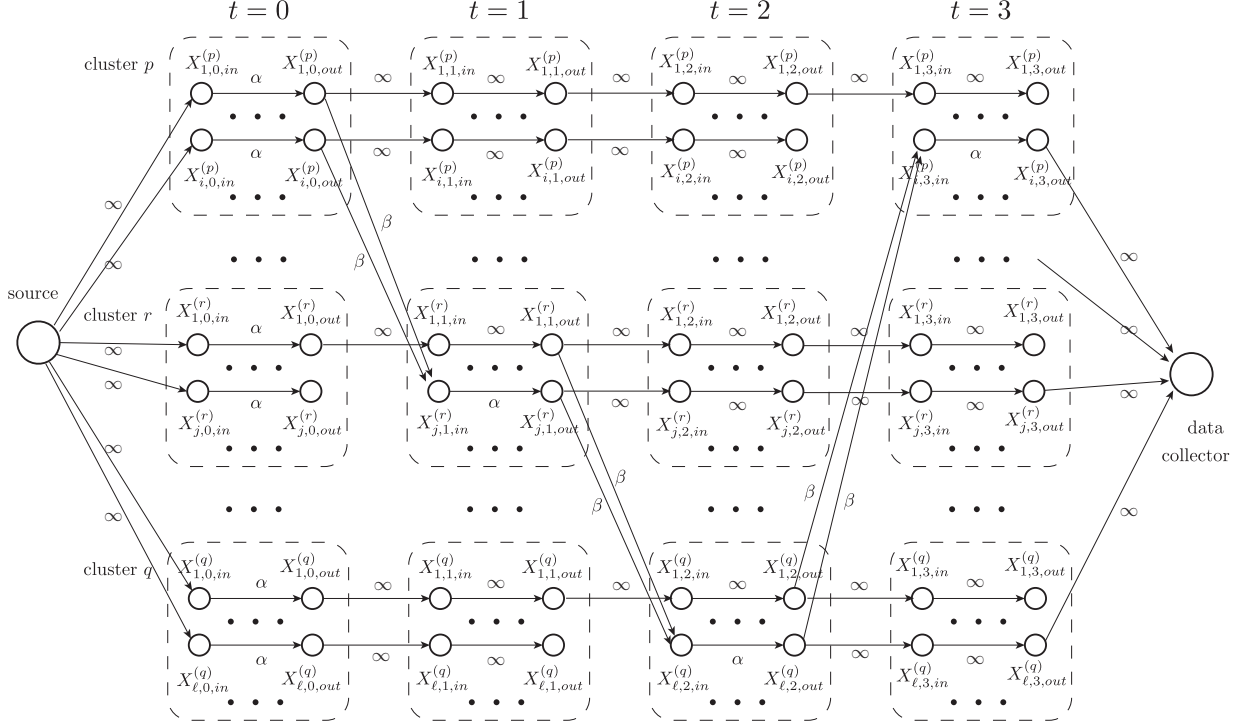

Fig. 2. The network information flow model for the FCRS. At the end of $t = 0, 1, 2$ the servers $X_{j,0}^{(r)}, X_{l,1}^{(q)}$ and $X_{i,2}^{(p)}$ fail respectively. These servers are repaired by connecting to clusters p, r and q , in that order. Finally a data collector connects to k servers at time slot $t = 3$ for recovering the file \mathcal{M} . Note that some of these k servers are newcomers.

Our goal in this section is to find the minimum cut that separates any data collector from the source in this graph under all possible failure and repair patterns. As we shall see this minimum cut helps us to characterize the smallest possible value of α for any choice of $\gamma = d\beta$, such that any data collector can recover the file. Furthermore, the tradeoff (α, γ) characterized by this min-cut is achievable, for instance if we resort to random linear codes [23].

Consider a sequence of failures and repairs as depicted in Figure 3. Note that only two clusters participate in this sequence. First, $k_1 \geq \lceil \frac{k}{2} \rceil$ servers from the first cluster fail. All of these servers are repaired by connecting the second cluster. Next, $k_2 = k - k_1$ servers from the second cluster fail. These servers are repaired by the first cluster. Assume a data collector connects to these k newcomers in order to recover the file \mathcal{M} . As we shall see soon, a simple cut-set argument shows that we must have

$$M \leq k_1\alpha + (d - k_1)(k - k_1)\beta.$$

Our first objective is to prove that for any choice of the parameters α and $d\beta$, there exists a $k_1 \in [\lceil \frac{k}{2} \rceil : k]$ such that this is the smallest cut which separates any data collector from the source. Let us assume that at some arbitrary point in time, t_0 , a data collector is connected to k servers which we call $Z_{1,t_0}, \dots, Z_{k,t_0}$. For any $i \in [1 : k]$ let $t_i \leq t_0$ be the smallest integer such that an edge of infinite capacity exists from $Z_{i,t',out}$ to $Z_{i,t'+1,in}$ for all $t' \in [t_i : t_0]$. If no such t_i exists, set $t_i = t_0$. We say that there is a path from Z_{i,t_i} to Z_{j,t_j} if there exists a $t' \in [t_i : t_j - 1]$ such that there is an edge of capacity β connecting $Z_{i,t',out}$ to $Z_{j,t'+1,in}$. We can order these k servers such that $i < j$ implies $t_i \leq t_j$. As a result, $i < j$ implies there

is no path from Z_{j,t_j} to Z_{i,t_i} . Let us assume that such an ordering is in place. Define $e_i \in [1 : s + 1]$ as the cluster to which Z_{i,t_0} belongs and let

$$c(i, j) = |\{\ell \text{ s.t. } \ell \leq j \text{ and } e_\ell = i\}| \text{ for } j \in [1 : k] \quad (2)$$

be the number of servers in $Z_{[1:j],t_0}$ which belong to the i 'th cluster. Let $F(Z_{[1:k],t_0})$ be the value of the minimum cut that separates a data collector connecting to $Z_{[1:k],t_0,out}$ from the source. In order to find this cut, we must decide for any $j \in [1 : k]$ whether to include both $Z_{j,t_j,in}$ and $Z_{j,t_j,out}$ on the sink (data collector) side, or to include $Z_{j,t_j,in}$ on the source side and $Z_{j,t_j,out}$ on the sink side (if we include both $Z_{j,t_j,in}$ and $Z_{j,t_j,out}$ on the source side, the value of the cut will be infinite). In the latter case the value of the cut is increased by α , whereas in the former scenario, the value of the cut is increased by *at least* $(d - \max_{i \in [1:s+1] \setminus \{e_j\}} c(i, j))\beta$. This is because any newcomer must be repaired by a cluster differently from his own. As a result, the value of this cut must satisfy

$$F(Z_{[1:k],t_0}) \geq \sum_{j=1}^k \min\{(d - \max_{i \in [1:s+1] \setminus \{e_j\}} c(i, j))\beta, \alpha\}.$$

Let us represent this lower bound by

$$F^*(e_{[1:k]}) \triangleq \sum_{j=1}^k \min\{(d - \max_{i \in [1:s+1] \setminus \{e_j\}} c(i, j))\beta, \alpha\}. \quad (3)$$

Note that for fixed parameters α, d and β , the expression in (3) is uniquely determined by the sequence $e_{[1:k]}$, hence the change of the argument in $F^*(\cdot)$ from $Z_{[1:k],t_0}$ to merely $e_{[1:k]}$. The first lemma tells us that among all different sequences $e_{[1:k]}$ the value of $F^*(e_{[1:k]})$ is minimized when this sequence has a very specific structure.

Lemma 1: For any sequence $e_{[1:k]} \in [1 : s + 1]^k$, there exists a sequence $e'_{[1:k]} \in [1 : 2]^k$ such that $F^*(e'_{[1:k]}) \leq F^*(e_{[1:k]})$.

Proof:

Let $c(i, j)$ be as defined in (2) and

$$e'_j \triangleq \begin{cases} 1 & \text{if } c(e_j, j-1) = \max_{i \in [1:s+1]} c(i, j-1) \\ 2 & \text{Otherwise.} \end{cases}$$

for $j \in [2 : k]$ and $e'_1 \triangleq 1$. Define two variables as follows.

$$v_2(j) \triangleq \begin{cases} 0 & \text{if } j = 0 \\ v_2(j-1) + e'_j - 1 & \text{if } 0 < j \leq k \end{cases} \quad (4)$$

and

$$v_1(j) \triangleq j - v_2(j). \quad (5)$$

For any finite discrete set D , let $\max_{i \in D}^{(2)} f(i)$ return the second largest value of $f(\cdot)$ over D (if the maximizer of $f(\cdot)$ over D is not unique, then $\max_{i \in D}^{(2)} f(i) = \max_{i \in D} f(i)$). We proceed by proving the following two claims: $v_1(j) = \max_{i \in [1:s+1]} c(i, j)$ and $v_2(j) \geq \max_{i \in [1:s+1]}^{(2)} c(i, j)$. The first claim can be proven by induction. Trivially, $v_1(1) = 1 = \max_i c(i, 1)$. Assume the hypothesis is true for $j - 1$. Then

$$\begin{aligned} v_1(j) &= \mathbb{1}\{e'_j = 1\}(v_1(j-1) + 1) + \mathbb{1}\{e'_j = 2\}v_1(j-1) \\ &= \mathbb{1}\{c(e_j, j-1) = \max_i c(i, j-1)\}(\max_i c(i, j-1) + 1) \\ &\quad + \mathbb{1}\{c(e_j, j-1) < \max_i c(i, j-1)\} \max_i c(i, j-1) \\ &= \max_i c(i, j). \end{aligned}$$

The second claim follows because $v_2(j) = j - v_1(j) = j - \max_i c(i, j) = \sum_{i \neq i^*} c(i, j) \geq \max^{(2)} c(i, j)$ where $i^* = \arg \max_i c(i, j)$.

As a result, we have $\max_{i \in [1:s+1] \setminus \{e_j\}} c(i, j) \leq (e'_j - 1)v_1(j) + (2 - e'_j)v_2(j)$ for any $j \in [1 : k]$. Therefore,

$$F^*(e'_{[1:k]}) \geq \sum_{j=1}^k \min\{(d - (e'_j - 1)v_1(j) - (2 - e'_j)v_2(j))\beta, \alpha\}.$$

Now consider a sequence of failures and repairs occurring at $t = j \in [1 : k]$ such that if $e'_j = 1$ a server from the first cluster fails and is repaired by the second cluster, and if $e'_j = 2$ then a server from the second cluster fails and is repair by the first cluster. At each time-slot the parameters $v_1(j)$ and $v_2(j)$ represent the number of failed servers from the first and the second cluster respectively. Therefore we can write

$$F^*(e'_{[1:k]}) = \sum_{j=1}^k \min\{(d - (e'_j - 1)v_1(j) - (2 - e'_j)v_2(j))\beta, \alpha\}, \quad (6)$$

thus, $F^*(e'_{[1:k]}) \leq F^*(e_{[1:k]})$. ■

Suppose now that we are given an arbitrary sequence $e'_{[1:k]}$ such that $e'_i \in \{1, 2\}$. The next question is then how to sort the elements of $e'_{[1:k]}$ such that the expression in Equation (6) is minimized. It turns out there is a simple and global answer to this equation. Assume without loss of generality that $v_1(k) \geq v_2(k)$. The next lemma tells us that the the failures from each cluster must occur consecutively, without being interrupted. Specifically, $v_1(k)$ servers must fail from the first cluster, and only then, $v_2(k)$ servers fail from the second. Such a pattern always minimizes (6) regardless of the value of α and $d\beta$.

Lemma 2: Let $e'_{[1:k]} \in [1 : 2]^k$ be an arbitrary binary sequence of length k and let $v_1(j)$ and $v_2(j)$ be as defined in equations (5) and (4). Assume without loss of generality that $v_1(k) \geq v_2(k)$. We have

$$F^*(e'_{[1:k]}) \geq v_1(k)\alpha + v_2(k) \min\{(d - v_1(k))\beta, \alpha\}. \quad (7)$$

This is achieved with equality if $e'_{[1:k]}$ is sorted, i.e. if $e'_{[1:v_1(k)]}$ are all ones.

Proof: Let us for simplicity define $f(\alpha) = \sum_{j=1}^k \min\{(d - (e'_j - 1)v_1(j) - (2 - e'_j)v_2(j))\beta, \alpha\}$ and $g(\alpha) = v_1(k)\alpha + v_2(k) \min\{(d - v_1(k))\beta, \alpha\}$. The proof follows from three simple observations.

- As long as $\alpha \leq (d - v_1(k))\beta$ we have $f(\alpha) = g(\alpha) = k\alpha$.
- The curve $f(\alpha)$ is concave within $(d - v_1(k))\beta \leq \alpha \leq d\beta$ whereas the curve $g(\alpha)$ is linear within the same interval.
- $f(d\beta) = g(d\beta)$.

To see why the last claim holds, note that

$$\begin{aligned} f(d\beta) &= \sum_{j=1}^k (d - (e'_j - 1)v_1(j) - (2 - e'_j)v_2(j))\beta \\ &= kd\beta - \beta \left(\sum_{j=1}^k (e'_j - 1)v_1(j) + (2 - e'_j)v_2(j) \right). \end{aligned}$$

Since $g(d\beta) = kd\beta - v_1(k)v_2(k)\beta$, it is left to show that $\sum_{j=1}^k (e'_j - 1)v_1(j) + (2 - e'_j)v_2(j) = v_1(k)v_2(k)$. This can be proved by induction over k . For $k = 1$, the result trivially holds. Let us assume it is true for $k - 1$. Then:

$$\begin{aligned} \sum_{j=1}^k (e'_j - 1)v_1(j) + (2 - e'_j)v_2(j) &= v_1(k-1)v_2(k-1) + (e'_k - 1)v_1(k) + (2 - e'_k)v_2(k) \\ &= (v_1(k) + e'_k - 2)(v_2(k) - e'_k + 1) + (e'_k - 1)v_1(k) + (2 - e'_k)v_2(k) \\ &= v_1(k)v_2(k). \end{aligned}$$

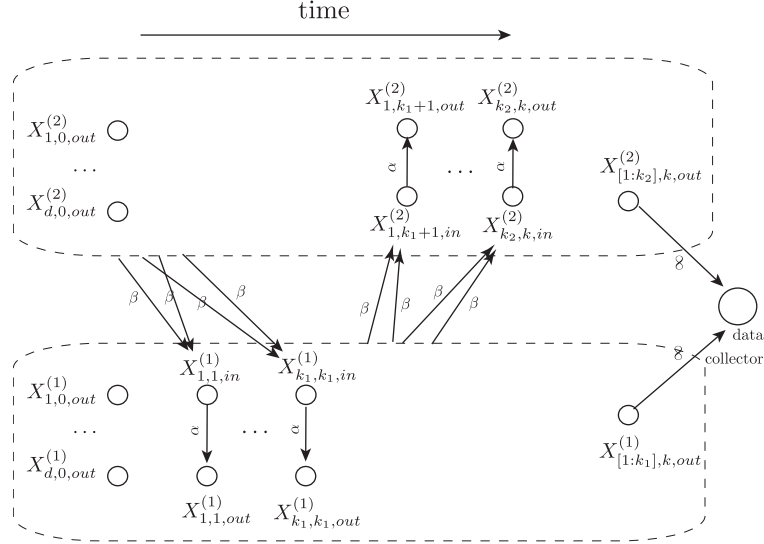

Fig. 3. Network information flow graph corresponding to a sequence of failures and repairs where $k_1 \geq \lceil \frac{k}{2} \rceil$ servers from the first cluster fail, followed by $k_2 = k - k_1$ failures from the second cluster. Each failure in cluster 1 is repaired by cluster 2 and vice versa. A data collector is connected to the k newcomers.

Remember that $F^*(e'_{[1:k]})$ is merely a lower bound on value of the min-cut separating any data collector from the source. But it is easy to find a cut the value of which is given by Equation (7). The sequence of failures and repairs leading to this cut is what is depicted in Figure 3: at the end of each time slot $t \in [0 : k_1 - 1]$ the server $X_{t+1,t}^{(1)}$ fails and is repaired by the second cluster. Next, at the end of each time slot $t \in [k_1 : k - 1]$ the server $X_{t-k_1+1,t}^{(2)}$ fails and is repaired by the first cluster. Then a data collector connects to the k servers $X_{[1:k_1],k}^{(1)}$ and $X_{[1:k-k_1],k}^{(2)}$. For every $t \in [1 : k_1]$ we include $X_{t,t,in}^{(1)}$ on the source side of the cut and $X_{t,t,out}^{(1)}$ on the sink side. If $(d - k_1)\beta > \alpha$, we do exactly the same thing for the servers in $\{X_{t-k_1,t}^{(2)} | t \in [k_1 + 1 : k]\}$. Otherwise, if $(d - k_1)\beta \leq \alpha$ then for all $t \in [k_1 + 1 : k]$ we include both $X_{t-k_1,t,in}^{(2)}$ and $X_{t-k_1,t,out}^{(2)}$ on the sink side. Since $v_1(k) = k_1$ and $v_2(k) = k - k_1$, the value of this cut is precisely what is given by Equation (7).

We have therefore proved the claim which we made at the beginning of this section. The last question to answer is what is the optimal choice of k_1 for a specific value of α and $d\beta$. With a slight abuse of notation, let us denote by $F^*(\alpha, d\beta)$ the value of the min-cut for the FCRS with a storage of size α and a repair bandwidth of $\gamma = d\beta$.

Lemma 3: Suppose we have an FCRS with parameters n, k, s and $d = \lfloor \frac{n}{s} \rfloor$. The value of the min-cut separating any data collector from the source is given by

$$F^*(\alpha, d\beta) = \begin{cases} kd\beta - \lfloor \frac{k}{2} \rfloor \lceil \frac{k}{2} \rceil \beta & \text{if } d \leq \frac{\alpha}{\beta}, \\ k_1\alpha + (d - k_1)(k - k_1)\beta & \text{if } d + k - 2k_1 - 1 \leq \frac{\alpha}{\beta} < \min\{d + k - 2k_1 + 1, d\} \\ & \text{for } k_1 \in \lceil \lceil \frac{k}{2} \rceil : k \rceil, \\ k\alpha & \text{if } \frac{\alpha}{\beta} < d - k - 1. \end{cases} \quad (8)$$

Proof: Let us define $g(k_1) = k_1\alpha + (k - k_1) \min\{(d - k_1)\beta, \alpha\}$. We want to minimize $g(k_1)$ over $k_1 \in \lceil \lceil \frac{k}{2} \rceil : k \rceil$ for a specific choice of α and $d\beta$. Without loss of generality we can assume $(d - k - 1)\beta \leq \alpha \leq d\beta$. If $\alpha > d\beta$ then $g(k_1)$ is clearly minimized for $k_1 = \lceil \frac{k}{2} \rceil$ which matches with the first line of Equation (8). On the other hand, if $\alpha < (d - k - 1)\beta$ then $g(k_1)$ is minimized at $k_1 = k$ which yields the last line in (8). Let us now minimize a simpler function $h(k_1) = k_1\alpha + (d - k_1)(k - k_1)\beta$. This is a second degree polynomial in k_1 and evidently its minimizer over $k_1 \in \lceil \lceil \frac{k}{2} \rceil : k \rceil$ is $k_1^* = \min\{\lfloor \frac{1}{2}(d + k - \alpha/\beta) \rfloor, k\}$ where $\lfloor \cdot \rfloor$ returns

the closest integer to its argument. Note that $g(k_1) = \min\{k_1\alpha + (k - k_1)(d - k_1)\beta, k_1\alpha + (k - k_1)\alpha\} = \min\{h(k_1), k\alpha\}$, so the same k_1^* minimizes $g(\cdot)$ too. Finally, $k_1^* = \min\{\lfloor \frac{1}{2}(d + k - \alpha/\beta) \rfloor, k\}$ implies $d + k - 2k_1^* - 1 \leq \frac{\alpha}{\beta} \leq d + k - 2k_1^* + 1$ which is the same as the second line in Equation (8). ■

For any FCRS with parameters n, k, s and file size M we must have $M \leq F^*(\alpha, d\beta)$ given by Equation (8), otherwise there exists a sequence of failures and repairs after which a data collector (connecting to the newcomers) is incapable of recovering the file. Furthermore, satisfying $M \leq F^*(\alpha, d\beta)$ is sufficient for successfully repairing any sequence of failures, and for any data collector to recover the file, if we resort to random linear codes [23]. The function $F^*(\alpha, d\beta)$ can be inverted in order to find the minimum value of α for a specific choice of $d\beta$ and M , in much the same way as illustrated in [1]. We will sketch this - mostly replicated - proof for the sake of completeness. Let us summarize the result in the next theorem.

Theorem 1: The tradeoff between α and $\gamma = d\beta$ in an FCRS with parameters n, k, s and $d = \lfloor \frac{n}{s} \rfloor$ can be characterized as

$$\alpha^* = \begin{cases} \frac{M}{k} & \text{if } \gamma \in [f(0), \infty) \\ \frac{M - \frac{i}{d}(d - k + i)\gamma}{k - i} & \text{if } \gamma \in [f(i), f(i - 1)) \end{cases} \quad (9)$$

where

$$f(i) \triangleq \begin{cases} \frac{Md}{(2k - i - 1)i + k(d - k + 1)} & \text{if } 0 \leq i < \lfloor \frac{k}{2} \rfloor \\ \frac{Md}{kd - \lfloor \frac{k}{2} \rfloor \lceil \frac{k}{2} \rceil} & \text{if } i = \lfloor \frac{k}{2} \rfloor. \end{cases}$$

Proof: The function $M = F^*(\alpha, d\beta)$ can be inverted in terms of α .

$$\alpha^* = F^{-1}(m, d\beta) = \begin{cases} \frac{M}{k} & \text{if } 0 \leq M < k(d - k - 1)\beta \\ \frac{M - (d - k_1)(k - k_1)\beta}{k_1} & \text{if } (dk - k_1^2 - k_1)\beta \leq M < (dk - k_1^2 + k_1)\beta \text{ for } k_1 \in [\lceil \frac{k}{2} \rceil + 1 : k] \\ \frac{M - (d - \lceil \frac{k}{2} \rceil) \lfloor \frac{k}{2} \rfloor \beta}{\lceil \frac{k}{2} \rceil} & \text{if } (dk - \lceil \frac{k}{2} \rceil^2 - \lceil \frac{k}{2} \rceil)\beta \leq M \leq (dk - \lfloor \frac{k}{2} \rfloor \lceil \frac{k}{2} \rceil)\beta \end{cases}$$

If we write the conditions in terms of $d\beta$ we find

$$\alpha^* = \begin{cases} \frac{M}{k} & \text{if } d\beta \geq \frac{dM}{k(d - k - 1)} \\ \frac{M - (d - k_1)(k - k_1)\beta}{k_1} & \text{if } d\beta \in [\frac{dM}{dk - k_1^2 + k_1}, \frac{dM}{dk - k_1^2 - k_1}] \text{ for } k_1 \in [\lceil \frac{k}{2} \rceil + 1 : k] \\ \frac{M - (d - \lceil \frac{k}{2} \rceil) \lfloor \frac{k}{2} \rfloor \beta}{\lceil \frac{k}{2} \rceil} & \text{if } d\beta \in [\frac{dM}{dk - \lfloor \frac{k}{2} \rfloor \lceil \frac{k}{2} \rceil}, \frac{dM}{dk - \lceil \frac{k}{2} \rceil^2 - \lceil \frac{k}{2} \rceil}] \end{cases}$$

which is essentially the same as Equation (9). We intentionally substitute $i = k - k_1$ to find an expression similar to Equation (1) in [1]. ■

Let us denote by $(\alpha_{MBR,c}, \gamma_{MBR,c})$ the operating point at which the repair bandwidth of the FCRS is minimized. At this point we have

$$\gamma_{MBR,c} = f(\lfloor \frac{k}{2} \rfloor) = \frac{Md}{kd - \lfloor \frac{k}{2} \rfloor \lceil \frac{k}{2} \rceil}. \quad (10)$$

By plugging in this value in Equation (9) we find

$$\alpha_{MBR,c} = \frac{Md}{kd - \lfloor \frac{k}{2} \rfloor \lceil \frac{k}{2} \rceil} = \gamma_{MBR,c}.$$

Therefore,

$$(\alpha_{MBR,c}, \gamma_{MBR,c}) = \left(\frac{dM}{kd - \lfloor \frac{k}{2} \rfloor \lceil \frac{k}{2} \rceil}, \frac{dM}{kd - \lfloor \frac{k}{2} \rfloor \lceil \frac{k}{2} \rceil} \right).$$

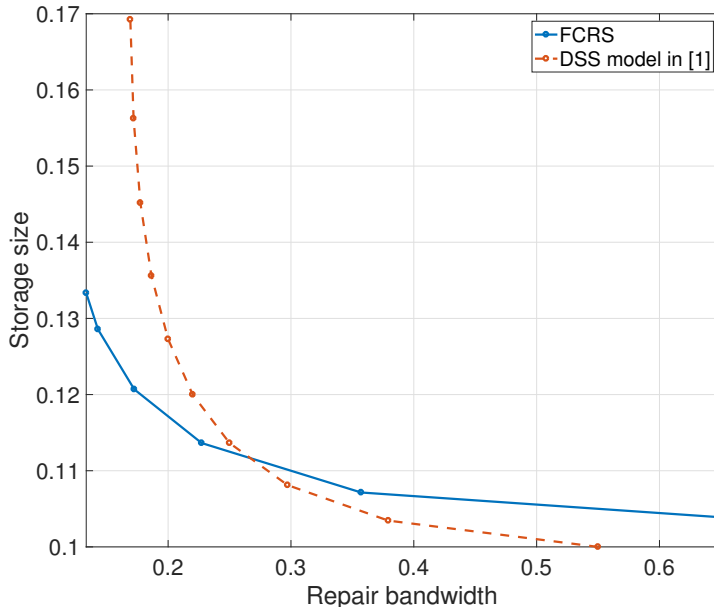

Fig. 4. Comparison of the achievable region (α, γ) for FCRS and [1]. We have $n = 100$, $k = 10$ and both schemes are required to achieve an availability of $s - 1 = 9$.

A. Comparison with [1]

As discussed in the introduction, random linear codes for FCRS can be viewed as an achievability scheme for a more general problem, ACRS, where we are given a DSS and we are required to characterize the region (α, γ) for any fixed availability, where α is the storage size and γ is the repair bandwidth as defined in Equation (1). Interestingly, although the parameter availability has not been a motivation behind the work in [1], their scheme serves as an achievability result for this general problem too, for any availability $s - 1 \in [1 : \lfloor \frac{n-1}{k} \rfloor]$. In particular, the random linear codes proposed in [1] can achieve an availability of $s - 1$ if we set $d = d_o = \lfloor \frac{n-1}{s-1} \rfloor$ whereas the random linear codes for FCRS with s complete and one incomplete clusters ($n = ds + s_0$) achieve an availability of $s - 1$ with $d = d_c = \lfloor \frac{n}{s} \rfloor$. In this section, we want to illustrate how FCRS can improve the tradeoff (α, γ) compared to [1] for the same availability and for certain range of parameters. To begin with, we find this comparison most interesting if neither system has any “residual servers”, namely if $s - 1 | n - 1$ and $s | n$. For instance let us select $n = k^2$ and $s = k$. For FCRS we will have k clusters each of size k and therefore $d_c = k$. For [1] we have $d_o = \frac{n-1}{s-1} = k + 1$. By plugging in these values of d in Equations (9) and Equation (1) from [1] respectively, we can find the smallest value of α for any repair bandwidth γ . This is precisely what we have plotted in Figure 4 for a choice of $n = 100$ and $k = 10$ (both repair bandwidth and storage size are normalized by M). The figure suggests that at small values of repair bandwidth FCRS has a superior performance, and that there is a threshold value of γ beyond which it is outperformed by [1]. The improvements offered by FCRS are most visible at the MBR point for which we are going to provide an analytical comparison. Let us define $\gamma_{MBR,o} \triangleq \frac{2d_o M}{2kd_o - k^2 + k}$ which is the value of the repair bandwidth at MBR point in [1]. The two conditions $s | n$ and $s - 1 | n - 1$ imply that $n = (\ell s - \ell + 1)s$ for some positive integer ℓ . Under this constraint we have $d_o = \ell s + 1$ and $d_c = \ell s - \ell + 1$ and we can write

$$\frac{\gamma_{MBR,c}}{\gamma_{MBR,o}} = \frac{\frac{d_c M}{kd_c - \lfloor \frac{k}{2} \rfloor \lceil \frac{k}{2} \rceil}}{\frac{2d_o M}{2kd_o - k^2 + k}} \leq \frac{\frac{d_c M}{kd_c - \frac{k^2}{4}}}{\frac{2d_o M}{2kd_o - k^2 + k}} = \frac{\ell s + 1 - (k - 1)/2}{\ell s - \ell + 1 - k/4} \cdot \frac{\ell s - \ell + 1}{\ell s + 1}.$$

This ratio is upper-bounded by 1 for almost the entire range of parameters (except when $s = 2$ or $k = 1$ or when $(s, k) \in \{(3, 2), (3, 3), (4, 2)\}$) as can be easily verified. The ratio is smallest when s is maximal,

that is, $s = \lfloor \frac{n}{k} \rfloor$. This implies $k = \ell s - \ell + 1$, which results in

$$\frac{\gamma_{MBR,c}}{\gamma_{MBR,o}} \leq \frac{2}{3} \cdot \frac{\ell s + \ell + 2}{\ell s + 1}.$$

This can be upper-bound by

$$\frac{\gamma_{MBR,c}}{\gamma_{MBR,o}} \leq \frac{2}{3} \cdot \frac{s + 3}{s + 1}$$

which is achieved when $\ell = 1$. This indicates an asymptotic multiplicative improvement of $2/3$ over the repair bandwidth at MBR point in comparison to [1].

It is worth noting that the assumption of “no residual server” becomes irrelevant as the parameters k and s grow large and as long as we choose $s = \lfloor \frac{n}{k} \rfloor$.

Proposition 1: Let s , k and s_0 be three positive integers such that $0 \leq s_0 < \min\{k, s\}$. Let $n = sk + s_0$, $d_c = \lfloor \frac{n}{s} \rfloor = k$ and $d_o = \lfloor \frac{n-1}{s-1} \rfloor$, and define

$$f(s, k, s_0) \triangleq \frac{\gamma_{MBR,c}}{\gamma_{MBR,o}} = \frac{\frac{d_c}{kd_c - \lfloor \frac{k}{2} \rfloor \lceil \frac{k}{2} \rceil}}{\frac{2d_o}{2kd_o - k^2 + k}}.$$

We have

$$f(s, k, s_0) \leq \frac{2}{3} \cdot \frac{(s+3)k + s - 3}{(s+1)k - 1}.$$

Proof:

$$\begin{aligned} f(s, k, s_0) &\leq \frac{\frac{d_c}{kd_c - \frac{k^2}{4}}}{\frac{2d_o}{2kd_o - k^2 + k}} = \frac{d_c}{d_c - \frac{k}{4}} \cdot \frac{2d_o - k + 1}{2d_o} \leq \frac{2}{3} \cdot \frac{2d_o - k + 1}{d_o} \\ &\leq \frac{2}{3} \left(2 - \frac{(k-1)(s-1)}{sk + s_0 - 1} \right) \leq \frac{2}{3} \left(2 - \frac{(k-1)(s-1)}{(s+1)k - 1} \right) = \frac{2}{3} \cdot \frac{(s+3)k + s - 3}{(s+1)k - 1}. \end{aligned}$$

As a result of this proposition we see that $\lim_{k \rightarrow \infty} f(s, k, s_0) \leq (\frac{2}{3} + \epsilon) \cdot \frac{s+3}{s+1}$. If we further let $s \rightarrow \infty$, the ratio of $\frac{2}{3}$ will be established. ■

This result may appear puzzling at first. Suppose the file \mathcal{M} consists of m independent symbols over a sufficiently large field \mathbb{F}_q so that $M = m \log(q)$. The random linear codes for FCRS require each server to store $\frac{\alpha}{\log(q)}$ random linear combinations of the m symbols of the file. If this server ever takes part in a repair process, he transmits $\frac{\beta}{\log q}$ random linear combinations of these $\frac{\alpha}{\log(q)}$ symbols to a newcomer. Eventually, the newcomer stores $\frac{\alpha}{\log(q)}$ random linear combinations of the received $\frac{d\beta}{\log q}$ symbols. But this is precisely the mechanism behind the random linear codes for [1] (or in essence, any other network flow problem). How is it possible that one code outperforms the other? The truth is that the two codes are different in that they choose different parameters α and $d\beta$. By excluding the possibility of certain repair patterns, we are able to achieve a larger min-cut on the network. Thereby, we can choose α and $d\beta$ smaller (at MBR point) without eventually running into trouble. This “exclusion” may come at a price depending on what the designer aims at optimizing. However, this cost is not reflected in the $(s-1, \alpha, \gamma)$ tradeoff for an ACRS at small repair bandwidth and large availability.

IV. THE EXACT REPAIR MODEL: ACHIEVABILITY RESULTS FOR MBR POINT

In this section we introduce cubic code as a coding scheme designed to minimize the repair bandwidth for the FCRS with $s + 1$ clusters where $2 \leq s \leq \lfloor \frac{n}{k} \rfloor$. Cubic Codes are examples of Affine Resolvable Designs [17] which themselves are subclasses of Fractional Repetition codes [16]. They can also be viewed as generalizations of grid codes discussed in [17]. As we shall prove in the next section via a converse bound, cubic codes are information-theoretically optimal, in the sense that they minimize the repair bandwidth of FCRS with 2 and 3 clusters and no residual server. On the other hand, they have a strictly worse performance compared to random linear codes that can achieve the cutset bound analyzed in Section III. This implies an inherent gap between the functional repair and exact repair models at the MBR point for the FCRS with 2 and 3 complete clusters. This is by contrast to the DSS model studied in [1] where the MBR point for functional and exact repair coincide. Despite this, we will show that cubic codes still achieve an asymptotic multiplicative improvement of 0.79 on the repair bandwidth compared to the MBR codes [2], [3] that guarantee the same availability.

Suppose as stated in Section II the network consists of $n = ds + s_0$ servers divided into s clusters of size d and one cluster of size $s_0 < s$. In this section we further assume that $s_0 < d$. If this is not true, we can increase s to s' such that $n = ds' + s'_0$ where $s'_0 < \min\{d, s'\}$ and $s' \leq \lfloor \frac{n}{k} \rfloor$. Also note that this condition is automatically satisfied if $k^2 \geq n$. Assuming the file is large enough, we break it into m independent chunks $\mathcal{M} = \{\mathcal{M}_1, \dots, \mathcal{M}_m\}$ so that $H(\mathcal{M}_i) = M/m$. The value of m will be determined shortly. We start by constructing a (d^{s+1}, m) MDS code over these m symbols and indexing the codewords by strings of $s + 1$ digits. Let C_b represent a codeword of the MDS code where b is a string of $s + 1$ digits, $b = b_{s+1} \dots b_1$, and $b_i \in [1 : d]$.

Server j in Cluster i stores all the codewords of the form C_b where $b_i = j$ and the other indices vary. That is,

$$X_j^{(i)} = \{C_b | b_i = j\} \quad \text{for all } (i, j) \in \{[1 : s] \times [1 : d]\} \cup \{\{s + 1\} \times [1 : s_0]\}.$$

This is akin to arranging the codewords of an MDS code in an $s + 1$ -dimensional hyper-cube and

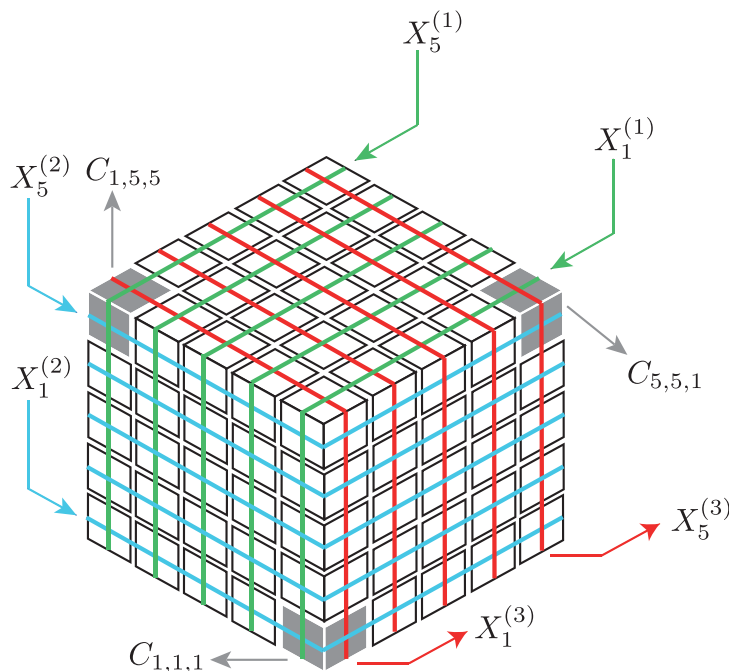

Fig. 5. Cubic Codes for the FCRS with 3 clusters and with $n = 15$, $d = 5$. The codewords of an MDS code (the small blocks) are arranged in a three dimensional cube. The j 'th node in the i 'th cluster stores the codewords that form that j 'th plane parallel to the i 'th axis.

requiring the servers within the i 'th cluster to store hyperplanes parallel to the i 'th axis. See Figure 5 for an illustration. One can also express this code in terms of its generator matrix. Let B be the generator matrix of any (d^{s+1}, m) MDS code. For any integer ℓ let $\phi_{s+1}(\ell) \dots \phi_1(\ell)$ be the $s+1$ -digit expansion of ℓ in base d , where $\phi_{s+1}(\cdot)$ represents the most significant digit. For any $(i, j) \in \{[1 : s] \times [1 : d]\} \cup \{s+1\} \times [1 : s_0]$ let $Q^{(i,j)}$ be the d^s by d^{s+1} matrix where

$$Q_{\ell,r}^{(i,j)} = \begin{cases} 1 & \text{if } \begin{cases} \phi_e(r) = \phi_e(\ell) & \text{for } e \in [1 : i-1] \text{ and} \\ \phi_e(r) = \phi_{e-1}(\ell) & \text{for } e \in [i+1 : s+1] \text{ and} \\ \phi_i(r) = j-1 \end{cases} \\ 0 & \text{otherwise.} \end{cases}$$

Then we can write

$$X_j^{(i)} = Q^{(i,j)} B[\mathcal{M}_1, \dots, \mathcal{M}_m]^T.$$

If a server $X_\ell^{(r)}$ fails and chooses cluster i for repair, then the j 'th server in cluster i transmits $Y_{\ell,j}^{(r,i)} = \{C_b | b_i = j, b_r = \ell\}$ to the newcomer. Upon receiving all such codewords $Y_{\ell,[1:d]}^{(r,i)}$, the newcomer is capable of reconstructing the failed server. Furthermore, the newcomer receives a total of d^s codewords which shows that for cubic codes $d\beta = \alpha$.

Let us now analyze the performance of this code. Based on the data recovery requirement, we know that every k servers in the network, regardless of their cluster must be able to recover the file. Consider a set of k servers chosen in such a way that k_i servers belong to cluster i where $\sum_{i=1}^{s+1} k_i = k$. These servers together provide a total of R codewords of the MDS code where

$$\begin{aligned} R &= \sum_{i=1}^{s+1} d^s k_i - \sum_{i=1}^{s+1} \sum_{j=i+1}^{s+1} d^{s-1} k_i k_j \\ &+ \sum_{i=1}^{s+1} \sum_{j=i+1}^{s+1} \sum_{\ell=j+1}^{s+1} d^{s-2} k_i k_j k_\ell - \dots \\ &= d^{s+1} - \prod_{i=1}^{s+1} (d - k_i). \end{aligned}$$

Thus, in order for the file \mathcal{M} to be recoverable from these k servers, we must have

$$d^{s+1} - \prod_{i=1}^{s+1} (d - k_i) \geq m. \quad (11)$$

Note that this inequality must be true for any choice of the parameters k_i . Let us therefore minimize the left hand side of this inequality over the constraints $\sum_{i=1}^{s+1} k_i = k$, $k_i \geq 0$ and $k_{s+1} \leq s_0$.

$$k_{[1:s+1]}^* = \arg \min_{k_{[1:s+1]}: \sum_{i=1}^{s+1} k_i = k \text{ and } k_{s+1} \leq s_0} d^{s+1} - \prod_{i=1}^{s+1} (d - k_i). \quad (12)$$

To solve this optimization problem, it is necessary to distinguish between two regimes.

- **Regime 1:** $s_0 \geq \lfloor \frac{k}{s+1} \rfloor$.

Define $s_1 = \text{mod}(k, s+1)$. The solution to (12) can be expressed as

$$k_i^* = \begin{cases} \lceil \frac{k}{s+1} \rceil & \text{if } i \leq s_1 \\ \lfloor \frac{k}{s+1} \rfloor & \text{if } s_1 < i \leq s+1. \end{cases}$$

Returning to Inequality (11) we can write $m = d^{s+1} - (d - \lceil \frac{k}{s+1} \rceil)^{s_1} (d - \lfloor \frac{k}{s+1} \rfloor)^{(s+1-s_1)}$. Since each server stores d^s codewords, the storage size is

$$\alpha = \frac{Md^s}{m} = \frac{Md^s}{d^{s+1} - (d - \lceil \frac{k}{s+1} \rceil)^{s_1} (d - \lfloor \frac{k}{s+1} \rfloor)^{(s+1-s_1)}}.$$

We saw that for cubic codes $\gamma = \alpha$. Therefore,

$$\gamma = \frac{Md^s}{d^{s+1} - (d - \lceil \frac{k}{s+1} \rceil)^{s_1} (d - \lfloor \frac{k}{s+1} \rfloor)^{(s+1-s_1)}}.$$

- **Regime 2:** $s_0 < \lfloor \frac{k}{s+1} \rfloor$.

This time define $s_1 = \text{mod}(k - s_0, s)$. The solution to (12) is

$$k_i^* = \begin{cases} \lceil \frac{k-s_0}{s} \rceil & \text{if } i \leq s_1 \\ \lfloor \frac{k-s_0}{s} \rfloor & \text{if } s_1 < i \leq s \\ s_0 & \text{if } i = s+1. \end{cases}$$

Again, plugging this into (11) we have

$$\begin{aligned} m &= d^{s+1} - (d - \lceil \frac{k-s_0}{s} \rceil)^{s_1} (d - \lfloor \frac{k-s_0}{s} \rfloor)^{s+1-s_1} \\ &\quad - (\lfloor \frac{k-s_0}{s} \rfloor - s_0) (d - \lceil \frac{k-s_0}{s} \rceil)^{s_1} (d - \lfloor \frac{k-s_0}{s} \rfloor)^{s-s_1} \\ &= d^{s+1} - (d - s_0) (d - \lceil \frac{k-s_0}{s} \rceil)^{s_1} (d - \lfloor \frac{k-s_0}{s} \rfloor)^{s-s_1}. \end{aligned}$$

Consequently,

$$\gamma = \alpha = \frac{Md^s}{d^{s+1} - (d - s_0) (d - \lceil \frac{k-s_0}{s} \rceil)^{s_1} (d - \lfloor \frac{k-s_0}{s} \rfloor)^{s-s_1}}.$$

Let us summarize this in the following theorem.

Theorem 2: Suppose we have an FCRS with parameters n, k, s where $n = ds + s_0$ and $s_0 < \min\{d, s\}$. The cubic codes achieve a repair bandwidth of

$$\gamma_{cc}(n, k, s) = \begin{cases} \frac{Md^s}{d^{s+1} - (d - \lceil \frac{k}{s+1} \rceil)^{s_1} (d - \lfloor \frac{k}{s+1} \rfloor)^{(s+1-s_1)}} & \text{if } s_0 \geq \lfloor \frac{k}{s+1} \rfloor \\ \frac{Md^s}{d^{s+1} - (d - s_0) (d - \lceil \frac{k-s_0}{s} \rceil)^{s_2} (d - \lfloor \frac{k-s_0}{s} \rfloor)^{s-s_2}} & \text{if } s_0 < \lfloor \frac{k}{s+1} \rfloor \end{cases} \quad (13)$$

where $s_1 = \text{mod}(k, s+1)$ and $s_2 = \text{mod}(k - s_0, s)$.

An interesting regime is when there are no residual servers, that is when $n = sd$. In this case we have

$$\gamma_{cc}(sd, k, s) = \frac{M/d}{1 - (1 - \lceil \frac{k}{s} \rceil / d)^{s_2} (1 - \lfloor \frac{k}{s} \rfloor / d)^{s-s_2}}. \quad (14)$$

This can be further simplified if we assume $s|k$.

$$\gamma_{cc}(sd, \ell s, s) = \frac{M/d}{1 - (1 - \frac{\ell}{d})^s}.$$

In fact, it follows from a simple argument that

$$\gamma_{cc}(sd, k, s) \leq \frac{M/d}{1 - (1 - \frac{k}{sd})^s}. \quad (15)$$

To see why, note that

$$\left(\frac{1 - \frac{\lfloor k/s \rfloor}{d}}{1 - \frac{k}{sd}} \right)^{s_2} \left(\frac{1 - \frac{\lfloor k/s \rfloor}{d}}{1 - \frac{k}{sd}} \right)^{s-s_2} \leq 1$$

which is true since the geometric mean of s numbers is upperbounded by their arithmetic mean.

It is not difficult to see that if we fix s and k , $\gamma_{cc}(n, k, s)$ is monotonically decreasing in n . This is because adding one more server to the last cluster cannot increase the expression $\min_{k_{[1:s+1]}} d^{s+1} - \prod_{i=1}^{s+1} (d - k_i)$. Based on this property and Equation (15) we can establish the following bound.

Corollary 1: Let $\gamma_{cc}(n, k, s)$ be the repair bandwidth of cubic codes for an FCRS with parameters n, k, s where $n = ds + s_0$ and $s_0 \leq \min\{s, d\}$. Then

$$\gamma_{cc}(n, k, s) \leq \frac{M/d}{1 - \left(1 - \frac{k}{(s+1)d}\right)^{s+1}}.$$

This bound is sufficiently tight for our purpose and we will resort to it for our analytical comparison in the next section.

A. Comparison with Functional Repair and [3]

Let us start with a numerical comparison. Here we fix the number of servers n and let the availability grow gradually. For every fixed availability we compare the repair bandwidth for the three schemes: the MBR point for functional repair of FCRS in Section III, that is expression (10), the MBR codes proposed in [3] (which corresponds to the functional repair MBR point in [1]) and finally the cubic codes, that is expression (13). For this numerical analysis we set $n = 400$, $k = 20$, and we let $s - 1$ grow from 1 to 19. We normalize the repair bandwidth by the size of the file. As can be seen in Figure 6, as s grows large cubic codes perform somewhere in between the functional repair points of FCRS and [1]. The multiplicative improvement over [1] can be measured around 0.79 at its peak, i.e. when $s - 1 = 19$. This will be theoretically justified next.

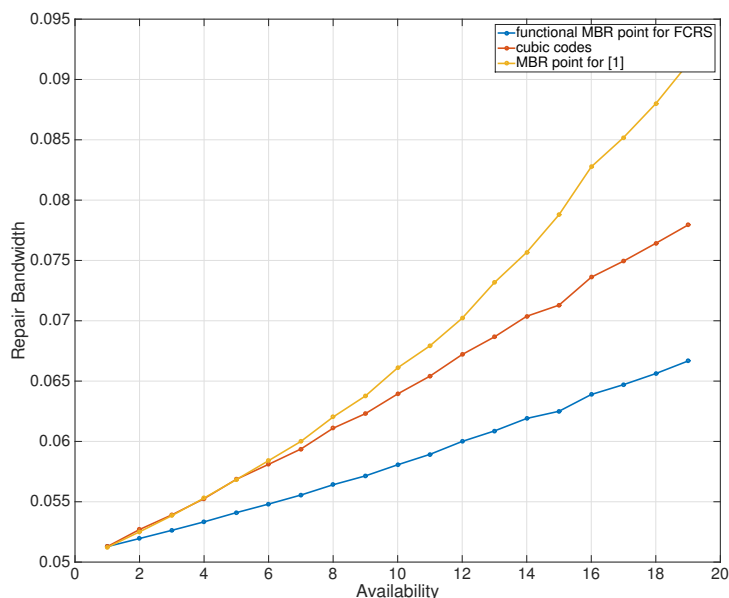

Fig. 6. Comparison of cubic codes with the functional repair MBR point of FCRS and the MBR point of [1] for $n = 400$, $k = 20$.

Let us first bound the ratio of repair bandwidth for cubic codes and functional repair bandwidth for the FCRS. Assuming k even we have

$$\begin{aligned} \frac{\gamma_{cc}}{\gamma_{MBR,c}} &\leq \frac{\frac{M/d_c}{1-(1-\frac{k}{(s+1)d_c})^{s+1}}}{\frac{M}{k-\frac{k^2}{4d_c}}} = \frac{k(1-\frac{k}{4d_c})}{d_c - d_c(1-\frac{k}{(s+1)d_c})^{s+1}} \\ &\leq \frac{k}{d_c}(1-\frac{k}{4d_c}) \frac{1}{1-e^{-k/d_c}} \leq \frac{3}{4(1-e^{-1})}. \end{aligned}$$

In conjunction with the results of Section III-A, if we further assume that s is chosen as large as possible, i.e. $s = \lfloor \frac{n}{k} \rfloor$, we can write

$$\frac{\gamma_{cc}}{\gamma_{MBR,o}} \leq \frac{3}{4(1-e^{-1})} \cdot \frac{2}{3} \cdot \frac{(s+3)k + s - 3}{(s+1)k - 1}.$$

Since the expression for the ratio $\frac{\gamma_{cc}}{\gamma_{MBR,o}}$ does not depend on whether k is odd or even, the same bound holds for general k . We have therefore established the following proposition.

Proposition 2: Let s , k and s_0 be three positive integers such that $s_0 < \min\{k, s\}$. Let $n = sk + s_0$, $d_c = \lfloor \frac{n}{s} \rfloor = k$ and $d_o = \lfloor \frac{n-1}{s-1} \rfloor$, and define

$$g(s, k, s_0) \triangleq \frac{\gamma_{cc}}{\gamma_{MBR,o}} \leq \frac{\frac{1}{1-(1-\frac{k}{(s+1)d_c})^{s+1}}}{\frac{2d_o}{2kd_o - k^2 + k}}.$$

We have

$$g(s, k, s_0) \leq \frac{1}{2(1-e^{-1})} \cdot \frac{(s+3)k + s - 3}{(s+1)k - 1}.$$

Based on this proposition, if we let $k \rightarrow \infty$, we find

$$\frac{\gamma_{cc}}{\gamma_{MBR,o}} \leq \frac{3}{4(1-e^{-1})} \cdot \left(\frac{2}{3} + \epsilon\right) \cdot \frac{s+3}{s+1} \approx 0.79 \cdot \frac{s+3}{s+1}.$$

This proves that for the same availability of $s-1 = \lfloor \frac{n}{k} \rfloor - 1$, cubic codes achieve an asymptotic (as $k, s, n \rightarrow \infty$) multiplicative improvement of 0.79 over the minimum repair bandwidth in comparison to MBR point in [1].

V. CONVERSE BOUND FOR EXACT REPAIR

In this section we provide an exact repair converse bound for the FCRS. The main purpose of this converse bound is to prove that the cubic codes introduced in Section IV minimize the repair bandwidth for the FCRS with two or three complete clusters and no residual servers. Unfortunately a straightforward generalization of the bound to more than three clusters is loose and is omitted for this reason. As we are dealing with exact repair we can drop the time index from X and Y variables, since $X_{j,t}^{(i)} = X_{j,t'}^{(j)}$ for all t and t' . Therefore, we simply represent this by $X_j^{(i)}$. The same slight change of notation applies for the helper variables Y .

Theorem 3: Cubic codes achieve the minimum repair bandwidth under exact repair for the FCRS with 2 or 3 complete clusters, i.e. when $s \in \{2, 3\}$ and $s_0 = 0$.

Proof: We will present the proof for $s = 3$. The proof for $s = 2$ is omitted to avoid redundancy. Therefore, we have $n = 3d$. Assume k_i servers from the i 'th cluster take part in the data recovery. Specifically, let $\tau_i \subseteq [1 : d]$ for $i \in [1 : 3]$ represent the set of indices of the servers from i 'th cluster that are connected to a data collector, such that $|\tau_i| = k_i$ and $\sum_{i=1}^3 k_i = k$. By taking an average over all possible such choices of τ_1, τ_2, τ_3 we can write

$$\begin{aligned}
M &\leq \frac{1}{\binom{d}{k_1}\binom{d}{k_2}\binom{d}{k_3}} \sum_{\substack{\tau_1, \tau_2, \tau_3 \\ \tau_i \subseteq [1:d], |\tau_i|=k_i}} H(X_{\tau_1}^{(1)}, X_{\tau_2}^{(2)}, X_{\tau_3}^{(3)}) \\
&= \frac{1}{\binom{d}{k_1}\binom{d}{k_2}\binom{d}{k_3}} \sum_{\tau_1, \tau_2, \tau_3} H(X_{\tau_3}^{(3)} | X_{\tau_2}^{(2)}, X_{\tau_1}^{(1)}) + \frac{1}{\binom{d}{k_1}\binom{d}{k_2}} \sum_{\tau_1, \tau_2} H(X_{\tau_2}^{(2)} | X_{\tau_1}^{(1)}) \\
&\quad + \frac{1}{\binom{d}{k_1}} \sum_{\tau_1} H(X_{\tau_1}^{(1)}). \tag{16}
\end{aligned}$$

Let us start by upper-bounding the first term.

$$\begin{aligned}
Q_3 &\triangleq \frac{1}{\binom{d}{k_1}\binom{d}{k_2}\binom{d}{k_3}} \sum_{\tau_1, \tau_2, \tau_3} H(X_{\tau_3}^{(3)} | X_{\tau_2}^{(2)}, X_{\tau_1}^{(1)}) \stackrel{(*)}{\leq} \frac{1}{\binom{d}{k_1}\binom{d}{k_2}\binom{d}{k_3}} \sum_{\tau_1, \tau_2, \tau_3} H(Y_{\tau_3, [1:d]}^{(3,2)} | Y_{\tau_3, \tau_2}^{(3,2)}, X_{\tau_1}^{(1)}) \\
&= \frac{1}{\binom{d}{k_1}\binom{d}{k_2}\binom{d}{k_3}} \sum_{\tau_1, \tau_2, \tau_3} H(Y_{\tau_3, [1:d] \setminus \tau_2}^{(3,2)} | Y_{\tau_3, \tau_2}^{(3,2)}, X_{\tau_1}^{(1)}) \stackrel{(\#)}{\leq} \frac{1}{\binom{d}{k_1}\binom{d}{k_3}} \sum_{\tau_1, \tau_3} \frac{d-k_2}{d} H(Y_{\tau_3, [1:d]}^{(3,2)} | X_{\tau_1}^{(1)}).
\end{aligned}$$

Inequality (*) follows from the fact that $H(X_{\tau_3}^{(3)} | Y_{\tau_3, [1:d]}^{(3,2)}) = 0$ and $H(Y_{\tau_3, \tau_2}^{(3,2)} | X_{\tau_2}^{(2)}) = 0$. Inequality (#) follows from (conditional) Han's inequality. Let us continue by bounding the right hand side of this inequality.

$$\begin{aligned}
Q_3 &\leq \frac{1}{\binom{d}{k_1}\binom{d}{k_3}} \sum_{\tau_1, \tau_3} \frac{d-k_2}{d} H(Y_{\tau_3, [1:d]}^{(3,2)} | X_{\tau_1}^{(1)}) \\
&= \frac{1}{\binom{d}{k_1}\binom{d}{k_3}} \sum_{\tau_1, \tau_3} \frac{d-k_2}{d} H(X_{\tau_3}^{(3)} | X_{\tau_1}^{(1)}) + \frac{1}{\binom{d}{k_1}\binom{d}{k_3}} \sum_{\tau_1, \tau_3} \frac{d-k_2}{d} H(Y_{\tau_3, [1:d]}^{(3,2)} | X_{\tau_1}^{(1)}, X_{\tau_3}^{(3)}) \\
&\leq \frac{1}{\binom{d}{k_1}\binom{d}{k_3}} \sum_{\tau_1, \tau_3} \frac{d-k_2}{d} H(Y_{\tau_3, [1:d]}^{(3,1)} | Y_{\tau_3, \tau_1}^{(3,1)}) + \frac{1}{\binom{d}{k_1}\binom{d}{k_3}} \sum_{\tau_1, \tau_3} \frac{d-k_2}{d} H(Y_{\tau_3, [1:d]}^{(3,2)} | X_{\tau_3}^{(3)}) \\
&\stackrel{(*)}{\leq} \frac{1}{\binom{d}{k_3}} \frac{(d-k_2)(d-k_1)}{d^2} \sum_{\tau_3} H(Y_{\tau_3, [1:d]}^{(3,1)}) + k_3(d-k_2)\beta - \frac{d-k_2}{d} \frac{1}{\binom{d}{k_3}} \sum_{\tau_3} H(X_{\tau_3}^{(3)}) \\
&\leq k_3 \frac{(d-k_2)(d-k_1)}{d} \beta + k_3(d-k_2)\beta - \frac{d-k_2}{d} \frac{1}{\binom{d}{k_3}} \sum_{\tau_3} H(X_{\tau_3}^{(3)}).
\end{aligned}$$

Inequality (*) follows from the fact that $H(Y|X) = H(Y) - H(X)$ if X is a function of Y and from applying Han's inequality for a second time. We go back to Equation (16) and bound the second term.

$$\begin{aligned}
Q_2 &\triangleq \frac{1}{\binom{d}{k_1}\binom{d}{k_2}} \sum_{\tau_1, \tau_2} H(X_{\tau_2}^{(2)} | X_{\tau_1}^{(1)}) \leq \frac{1}{\binom{d}{k_1}\binom{d}{k_2}} \sum_{\tau_1, \tau_2} H(Y_{\tau_2, [1:d]}^{(2,1)} | Y_{\tau_2, \tau_1}^{(2,1)}) \\
&= \frac{1}{\binom{d}{k_1}\binom{d}{k_2}} \sum_{\tau_1, \tau_2} H(Y_{\tau_2, [1:d] \setminus \tau_1}^{(2,1)} | Y_{\tau_2, \tau_1}^{(2,1)}) \\
&\leq \frac{1}{\binom{d}{k_2}} \frac{d-k_1}{d} \sum_{\tau_2} H(Y_{\tau_2, [1:d]}^{(2,1)}) \leq k_2(d-k_1)\beta.
\end{aligned}$$

Therefore, we proved

$$\begin{aligned}
M &\leq Q_3 + Q_2 + \frac{1}{\binom{d}{k_1}} \sum_{\tau_1} H(X_{\tau_1}^{(1)}) \\
&\leq k_3 \frac{(d-k_2)(d-k_1)}{d} \beta + k_3(d-k_2)\beta - \frac{d-k_2}{d \binom{d}{k_3}} \sum_{\tau_3} H(X_{\tau_3}^{(3)}) \\
&\quad + k_2(d-k_1)\beta + \frac{1}{\binom{d}{k_1}} \sum_{\tau_1} H(X_{\tau_1}^{(1)}).
\end{aligned}$$

Via an identical procedure we can more generally prove that if $\pi : \{1, 2, 3\} \rightarrow \{1, 2, 3\}$ is a bijection, then

$$\begin{aligned}
M &\leq k_{\pi_3} \frac{(d-k_{\pi_2})(d-k_{\pi_1})}{d} \beta + k_{\pi_3}(d-k_{\pi_2})\beta - \frac{d-k_{\pi_2}}{d \binom{d}{k_{\pi_3}}} \sum_{\tau_{\pi_3}} H(X_{\tau_{\pi_3}}^{(\pi_3)}) \\
&\quad + k_{\pi_2}(d-k_{\pi_1})\beta + \frac{1}{\binom{d}{k_{\pi_1}}} \sum_{\tau_{\pi_1}} H(X_{\tau_{\pi_1}}^{(\pi_1)}).
\end{aligned}$$

By averaging this inequality over all possible bijections π we find

$$\begin{aligned}
M &\leq k_3 \frac{(d-k_2)(d-k_1)}{3d} \beta + k_2 \beta \frac{(d-k_3)(d-k_1)}{3d} + k_1 \beta \frac{(d-k_3)(d-k_1)}{3d} \\
&\quad + \frac{1}{3} ((d-k_1)k_2 + (d-k_1)k_3 + (d-k_2)k_1 + (d-k_2)k_3 + (d-k_3)k_1 + (d-k_3)k_2) \beta \\
&\quad + \frac{1}{3} (k_1k_2 + k_1k_3 + k_2k_3) \beta \\
&= \frac{\beta}{3} (2dk + k_3 \frac{(d-k_2)(d-k_1)}{d} + k_2 \frac{(d-k_3)(d-k_1)}{d} + k_1 \frac{(d-k_2)(d-k_3)}{d} - k_1k_2 - k_1k_3 - k_2k_3) \\
&= \frac{\beta}{3d} (2d^2k + 3k_1k_2k_3 - 3d(k_1k_2 + k_1k_3 + k_2k_3) + d^2k) \\
&= \frac{\beta}{d} (d^3 - (d-k_1)(d-k_2)(d-k_3)),
\end{aligned}$$

where we have used the fact that $\alpha \leq d\beta$ (due to the repair requirement) and $\sum k_i = k$. Note that the inequality above must hold for any choice of k_1, k_2, k_3 that satisfy $\sum k_i = k$. In particular we must be able to choose $k_i = \lceil \frac{k}{3} \rceil$ for $i \in [1 : s_2]$ and $k_i = \lfloor \frac{k}{3} \rfloor$ for $i \in [s_2 + 1 : 3]$ where $s_2 = \text{mod}(k, 3)$. For this choice of $k_{[1:3]}$ we have

$$\gamma = d\beta \geq \frac{Md^2}{d^3 - (d - \lceil \frac{k}{3} \rceil)^{s_2} (d - \lfloor \frac{k}{3} \rfloor)^{3-s_2}} = \frac{M/d}{1 - (1 - \lceil \frac{k}{3} \rceil/d)^{s_2} (1 - \lfloor \frac{k}{3} \rfloor/d)^{3-s_2}}.$$

This is the same expression as the achievable repair bandwidth of cubic codes specified by Equation (14) if we set $s = 3$. ■

REFERENCES

- [1] A. G. Dimakis, P. B. Godfrey, Y. Wu, M. J. Wainwright, and K. Ramchandran, "Network coding for distributed storage systems," *IEEE Transactions on Information Theory*, vol. 56, no. 9, pp. 4539–4551, 2010.
- [2] K. Rashmi, N. B. Shah, P. V. Kumar, and K. Ramchandran, "Explicit construction of optimal exact regenerating codes for distributed storage," in *47th Annual Allerton Conference on Communication, Control, and Computing*. IEEE, 2009, pp. 1243–1249.
- [3] K. V. Rashmi, N. B. Shah, and P. V. Kumar, "Optimal exact-regenerating codes for distributed storage at the msr and mbr points via a product-matrix construction," *IEEE Transactions on Information Theory*, vol. 57, no. 8, pp. 5227–5239, 2011.
- [4] N. B. Shah, K. Rashmi, P. V. Kumar, and K. Ramchandran, "Interference alignment in regenerating codes for distributed storage: Necessity and code constructions," *IEEE Transactions on Information Theory*, vol. 58, no. 4, pp. 2134–2158, 2012.

- [5] V. R. Cadambe, S. A. Jafar, H. Maleki, K. Ramchandran, and C. Suh, "Asymptotic interference alignment for optimal repair of mds codes in distributed storage," *IEEE Transactions on Information Theory*, vol. 59, no. 5, pp. 2974–2987, 2013.
- [6] B. Sasidharan, K. Senthooor, and P. V. Kumar, "An improved outer bound on the storage-repair-bandwidth tradeoff of exact-repair regenerating codes," *arXiv preprint arXiv:1312.6079*, 2013.
- [7] N. Prakash and M. N. Krishnan, "The storage-repair-bandwidth trade-off of exact repair linear regenerating codes for the case $d = k - n - 1$," in *IEEE International Symposium on Information Theory (ISIT)*. IEEE, 2015, pp. 859–863.
- [8] C. Tian, "Rate region of the $(4, 3, 3)$ exact-repair regenerating codes," in *IEEE International Symposium on Information Theory (ISIT)*. IEEE, 2013, pp. 1426–1430.
- [9] A. S. Rawat, D. S. Papailiopoulos, A. G. Dimakis, and S. Vishwanath, "Locality and availability in distributed storage," *IEEE Transactions on Information Theory*, vol. 62, no. 8, pp. 4481–4493, 2016.
- [10] I. Tamo and A. Barg, "Bounds on locally recoverable codes with multiple recovering sets," in *IEEE International Symposium on Information Theory (ISIT)*. IEEE, 2014, pp. 691–695.
- [11] D. S. Papailiopoulos and A. G. Dimakis, "Locally repairable codes," *IEEE Transactions on Information Theory*, vol. 60, no. 10, pp. 5843–5855, 2014.
- [12] I. Tamo, D. S. Papailiopoulos, and A. G. Dimakis, "Optimal locally repairable codes and connections to matroid theory," *IEEE Transactions on Information Theory*, vol. 62, no. 12, pp. 6661–6671, 2016.
- [13] L. Parnianpour-Juarez, H. D. Hollmann, and F. Oggier, "Locally repairable codes with multiple repair alternatives," in *IEEE International Symposium on Information Theory (ISIT)*. IEEE, 2013, pp. 892–896.
- [14] A. Wang, Z. Zhang, and M. Liu, "Achieving arbitrary locality and availability in binary codes," in *IEEE International Symposium on Information Theory (ISIT)*. IEEE, 2015, pp. 1866–1870.
- [15] P. Huang, E. Yaakobi, H. Uchikawa, and P. H. Siegel, "Linear locally repairable codes with availability," in *IEEE International Symposium on Information Theory (ISIT)*. IEEE, 2015, pp. 1871–1875.
- [16] S. El Rouayheb and K. Ramchandran, "Fractional repetition codes for repair in distributed storage systems," in *48th Annual Allerton Conference on Communication, Control, and Computing*. IEEE, 2010, pp. 1510–1517.
- [17] O. Olmez and A. Ramamoorthy, "Fractional repetition codes with flexible repair from combinatorial designs," *IEEE Transactions on Information Theory*, vol. 62, no. 4, pp. 1565–1591, 2016.
- [18] N. Prakash, V. Abdrashitov, and M. Médard, "A generalization of regenerating codes for clustered storage systems," in *54th Annual Allerton Conference on Communication, Control, and Computing*, 2018.
- [19] —, "The storage vs repair-bandwidth trade-off for clustered storage systems," *arXiv preprint arXiv:1701.04909*, 2017.
- [20] B. Gastón, J. Pujol, and M. Villanueva, "A realistic distributed storage system: the rack model," *arXiv preprint arXiv:1302.5657*, 2013.
- [21] J. Parnas, C. Yuen, B. Gastón, and J. Pujol, "Non-homogeneous two-rack model for distributed storage systems," in *Information Theory Proceedings (ISIT), 2013 IEEE International Symposium on*. IEEE, 2013, pp. 1237–1241.
- [22] M. A. Tebbi, T. H. Chan, and C. W. Sung, "A code design framework for multi-rack distributed storage," in *IEEE Information Theory Workshop (ITW)*. IEEE, 2014, pp. 55–59.
- [23] T. Ho, M. Médard, R. Koetter, D. R. Karger, M. Effros, J. Shi, and B. Leong, "A random linear network coding approach to multicast," *IEEE Transactions on Information Theory*, vol. 52, no. 10, pp. 4413–4430, 2006.