

# BIOS ORAM: Improved Privacy-Preserving Data Access for Parameterized Outsourced Storage

Michael T. Goodrich  
University of California, Irvine  
Dept. of Computer Science  
goodrich@acm.org

## Abstract

Algorithms for oblivious random access machine (ORAM) simulation allow a client, Alice, to obfuscate a pattern of data accesses with a server, Bob, who is maintaining Alice’s outsourced data while trying to learn information about her data. We present a novel ORAM scheme that improves the asymptotic I/O overhead of previous schemes for a wide range of size parameters for client-side private memory and message blocks, from logarithmic to polynomial. Our method achieves statistical security for hiding Alice’s access pattern and, with high probability, achieves an I/O overhead that ranges from  $O(1)$  to  $O(\log^2 n / (\log \log n)^2)$ , depending on these size parameters, where  $n$  is the size of Alice’s outsourced memory. Our scheme, which we call BIOS ORAM, combines multiple uses of B-trees with a reduction of ORAM simulation to isogrammic access sequences.

## 1 Introduction

In *outsourced storage* applications, a client, Alice, outsources her data to a server, Bob, who stores her data and provides her with an interface to access it via a network. We assume that Bob is “honest-but-curious,” meaning that Bob is trusted to keep Alice’s data safe and available, but he wants to learn as much as he can about Alice’s data. For privacy protection, we also assume that Alice encrypts her data by a semantically secure encryption scheme so that each time she accesses an item then she securely re-encrypts it before returning it to Bob’s storage. The remaining problem, then, is for Alice to obscure her data access pattern so that Bob can learn nothing from her access sequence.

Fortunately, there is a large and growing literature on algorithms for oblivious random access machine (ORAM) simulation to obfuscate Alice’s access sequence (e.g., see [1, 2, 6, 9–12, 17, 19, 22, 23, 25]). Such ORAM simulation methods provide ways for Alice to replace each of the data accesses in her algorithm,  $\mathcal{A}$ , with a sequence of accesses to her data stored with Bob so as to obfuscate her original access sequence. Ideally, such an ORAM scheme achieves *statistical security*, which intuitively means that Bob is unable to determine any information about Alice’s original access sequence beyond its length,  $N$ , and the size of her data set,  $n$ . In addition to the parameters,  $n$  and  $N$ , the following parameters are also important in this context:

- $B$ : The maximum number of words in a message block sent from/to Alice in one I/O operation.

- $M$ : The number of words in Alice’s client-side private memory.

In this paper, we are interested in scenarios where  $B$  and  $M$  can be set to arbitrary values that are at least logarithmic in  $n$ , and at most a constant fraction of  $n$ , so as to apply to a wide range of scenarios, while still applying to cases where Alice would still be motivated to outsource her memory to Bob. Formally, in an ORAM framework, we assume that Alice’s RAM algorithm,  $\mathcal{A}$ , indexes data using integer addresses in the range  $[0, n - 1]$ , using the following operations:

- $\text{write}(i, v)$ : Write the value  $v$  into the memory cell indexed by the integer,  $i$ . Since  $\mathcal{A}$  is a RAM algorithm, we assume  $i$  and  $v$  each fit in a single memory word.
- $\text{read}(i)$ : Read and return the value,  $v$ , stored in the cell with integer address,  $i$ .

These operations are the low-level accesses that are issued during Alice’s execution of her RAM algorithm,  $\mathcal{A}$ . The goal of an ORAM simulation scheme is to allow Alice to perform her algorithm,  $\mathcal{A}$ , but to replace each individual read or write operation with a sequence of input/output (I/O) messages exchanged between Alice and Bob so that Alice effectively hides  $\mathcal{A}$ ’s pattern of data accesses, i.e.,  $\mathcal{A}$ ’s sequence of read/write operations. Moreover, we would like to minimize the amortized number of such messages exchanged between Alice and Bob while still preserving Alice’s privacy.

A related concept is that of an *oblivious storage* (OS), e.g., see [1, 2, 12, 19, 23, 24]. In this framework, Alice stores a dictionary at the server, Bob, of size at most  $n$ , and her algorithm,  $\mathcal{A}$ , accesses this dictionary using the following operations:

- $\text{put}(k, v)$ : Add the key-value item,  $(k, v)$ . An error occurs if there is already an item with this key. We assume here that each key,  $k$ , fits in a single memory word and each value,  $v$ , fits in a message block of size  $B$ .
- $\text{get}(k)$ : Return and remove the value,  $v$ , associated with the key,  $k$ . If there is no item in the collection with key  $k$ , then return a special “not found” value.

Note that OS includes ORAM as a special case. For example, we can initialize  $\mathcal{A}$ ’s memory,  $A[0..n-1]$ , as  $\text{put}(i, A[i])$ , for  $i = 0, \dots, n-1$ . Then we can perform any  $\text{write}(i, v)$  as  $\text{get}(i), \text{put}(i, v)$ , and we can perform any  $\text{read}(i)$  as  $v = \text{get}(i), \text{put}(i, v)$ . We assume that Alice’s original access sequence has a given length,  $N$ , where  $N$  is at most polynomial in  $n$ , and an OS scheme replaces each such operation with a sequence of operations that obfuscate the original access sequence. Ideally, Bob should learn nothing about Alice’s original access sequence, which we formalize in terms of a security game. Let  $\sigma$  denote a sequence of  $N$  read/write operations (or get/put operations). An ORAM (resp., OS) scheme transforms  $\sigma$  into into a sequence,  $\sigma'$ , of access operations. As mentioned above, we assume that each item is stored using a semantically-secure encryption scheme, so that independent of whether Alice wants to keep a key-value item unchanged, the sequence  $\sigma'$  involves always replacing anything Alice accesses with a new encrypted value so that Bob is unable to tell if the underlying plaintext value has changed. The security for an ORAM (or OS) simulation is defined in terms of the following security game. Let  $\sigma_1$  and  $\sigma_2$  be two different RAM-algorithm or dictionary access sequences, of length  $N$ , for a key/index set of size  $n$ , that are chosen by Bob and given to Alice. Alice chooses uniformly at random one of these sequences and transforms it into the access sequence  $\sigma'$  according to her ORAM (or OS) scheme, which she then executes. Her ORAM (resp., OS) scheme is *statistically secure* if Bob can determine which sequence,  $\sigma_1$  or  $\sigma_2$ , Alice chose

with probability at most  $1/2$ . This assumes that Bob learns nothing from the encryption of Alice’s data.

The *I/O overhead* for such an OS or ORAM scheme is a function,  $T(n)$ , such that the total number of messages sent between Alice and Bob during the simulation of all  $N$  of her accesses from  $\sigma$  is  $O(N \cdot T(n))$  with high probability (i.e., with probability at least  $1 - 1/n^c$ , for some constant  $c > 1$ ). That is, the I/O overhead is the amortized expected number of accesses to Bob’s storage that are done to hide each of Alice’s original accesses in her algorithm,  $\mathcal{A}$ . Of course, we would like  $T(n)$  to be as small as possible.

In this paper, we provide methods for improving the asymptotic I/O overhead for ORAM simulations by more than just constant factors. The approach we take to achieve this goal is to first transform the original RAM access sequence,  $\sigma$ , into an intermediate OS sequence,  $\hat{\sigma}$ , which has a restricted structure that we refer to as it being *isogrammic*, and we then efficiently implement an oblivious storage for this isogrammic sequence,  $\hat{\sigma}$ , transforming it into a final access sequence,  $\sigma'$ , by taking advantage of this restricted structure. We define a sequence,  $\sigma = (\sigma_1, \sigma_2, \dots, \sigma_N)$  of **put** and **get** operations to be *isogrammic*<sup>1</sup>, for an underlying set of size,  $n$ , if it satisfies the following conditions:

- For every **get**( $k$ ) operation, there is a previous **put**( $k, v$ ) operation, with the same key,  $k$ .
- No **put**( $k, v$ ) operation attempts to add an item ( $k, v$ ) when the key  $k$  is already in the set.
- The key,  $k$ , used in each **get**( $k$ ) (resp., **put**( $k, v$ )) operation contains random component chosen independently and uniformly of at least  $\lceil \log n \rceil$  bits. Thus, keys are unlikely to be repeated.

That is, each time we issue a **put**( $k, v$ ) operation, the key,  $k$ , contains a random nonce that is chosen independently from any of the previous random nonces we chose for previous keys. At a high level, then, our two-phase ORAM simulation scheme is surprisingly simple, in that it combines the classic well-known B-tree data structure, which is ubiquitous in database applications, with isogrammic OS. That is, at a high level our scheme can be summarized as

$$\mathbf{B-trees} + \mathbf{Isogrammic-OS} \implies \mathbf{ORAM}.$$

Thus, we call our scheme *BIOS ORAM*.<sup>2</sup> This approach allows us to achieve the main goals of this paper, which is the design of ORAM simulation methods that work for a wide range of values to the parameters  $B$  and  $M$ . Moreover, we are able to use this approach to design schemes that are statistically secure and, w.h.p., have efficient I/O overhead bounds.

## 1.1 Previous Related Results

Work on ORAM simulation methods traces its origins to seminal work of Goldreich and Ostrofsky [9], who achieve an I/O overhead of  $O(\log^3 n)$  with  $M$  and  $B$  being  $O(1)$  using a scheme

<sup>1</sup>An *isogram* is a word, like “copyrightable,” without a repeated letter. E.g., see [wikipedia.org/wiki/Isogram](http://wikipedia.org/wiki/Isogram).

<sup>2</sup>Our scheme implements an ORAM by a reduction to an isogrammic OS, i.e., by replacing a sequence of **read** and **write** operations with a sequence of **get** and **put** operations. If one desires a scheme that works entirely in the ORAM framework, one can, for example, implement these **get** and **put** operations using a cuckoo hash table, with  $O(1)$  lookup times in the worst case and  $O(1)$  amortized insertion times with high probability (w.h.p.). This will result in a sequence of **read** and **write** operations and it does not reveal any information about Alice’s original access sequence, since the **get** and **put** operations come from an OS.

Method	Parameterizable?	Statistically Secure?	$B$	$M$	I/O Overhead
Goldreich-Ostrosfsky [9]	No	No	$\Theta(1)$	$\Theta(1)$	$O(\log^3 n)$
Kushilevitz <i>et al.</i> [17]	No	No	$\Theta(1)$	$\Theta(1)$	$O(\log^2 n / \log \log n)$
Damgård <i>et al.</i> [6]	No	Yes	$\Theta(1)$	$\Theta(1)$	$O(\log^3 n)$
Supermarket ORAM [3]	No	Yes	$\Theta(1)$	$\Theta(\text{polylog } n)$	$O(\log^2 n \log \log n)$
Goodrich-Mitzenmacher [10]	Somewhat	No	$\Theta(1)$	$\Theta(n^\epsilon)$	$O(\log n)$
Melbourne shuffle [19]	Somewhat	No	$\Theta(n^\epsilon)$	$\Theta(n^\epsilon)$	$O(1)$
Path ORAM [25]	Yes	Yes	$\omega(\log n)$	$\omega(B \log n)$	$O(\log^2 n / \log B)^\dagger$
<b>BIOS ORAM</b>	<b>Yes</b>	<b>Yes</b>	$\Omega(\log n)$	$\Omega(\log n)$	$O(\log^2 n / \log^2 B)$

Table 1: Our BIOS ORAM bounds (in boldface), compared to some of the asymptotically best previous ORAM methods, which are distinguished between those results have parameterized message/memory sizes or not, and those that are statistically secure or not. The parameter  $0 < \epsilon \leq 1/2$  is a fixed constant. The above results that are not statistically secure assume the existence of random one-way hash functions, i.e., they assume the existence of random oracles.

<sup>†</sup>The Path ORAM method [25] claims an I/O bandwidth of  $O(\log n)$  blocks, but this assumes that blocks can contain the responses of multiple back-and-forth messages; hence, we use the above bound to characterize the I/O overhead for Path ORAM, which counts the actual number of messages, each of size at most  $B$ .

that fails with polynomial probability and is not statistically secure. Kushilevitz *et al.* [17] improve the I/O overhead for ORAM with a constant-size client-side memory to be  $O(\log^2 n / \log \log n)$ , albeit while still not achieving statistical security. Damgård *et al.* [6] introduce an ORAM scheme that is statistically secure with an I/O overhead that is  $O(\log^3 n)$ , with  $M$  and  $B$  being  $O(1)$ , that is, their method is not parameterized for general values of  $M$  and  $B$ . Chung *et al.* [3] provide a statistically secure ORAM scheme, which we are calling “supermarket” ORAM (due to its reliance on an interesting “supermarket” analysis), for the case when  $B$  is  $O(1)$  and  $M$  is at least polylogarithmic, which has an I/O overhead of  $O(\log^2 n \log \log n)$ . Unfortunately, these previous schemes do not apply to parameterized scenarios with larger values for  $B$ , such as when  $B$  is at least logarithmic, let alone for cases when  $B$  is  $\Omega(n^\epsilon)$ , for some constant  $0 < \epsilon \leq 1$ . Interestingly, Goldreich and Ostrosfsky [9] give a lower-bound argument that the I/O overhead for an ORAM scheme must be  $\Omega(\log n)$  when  $M$  is  $O(1)$ , but their lower bound does not apply to larger values of  $M$  and  $B$ .

There is previous work that is parameterized for larger values of  $M$  and  $B$ , however. Goodrich and Mitzenmacher [10] provide an ORAM simulation scheme that achieves an  $O(\log n)$  I/O overhead and constant-sized messages, but their method requires  $M$  to be  $\Omega(n^\epsilon)$ , for some fixed constant  $0 < \epsilon \leq 1$ , which is not fully parameterized, e.g., for when  $M$  is polylogarithmic. Also, their method is not statistically secure. Stefanov *et al.* [25] introduce the Path ORAM method, which is statistically secure and parameterized for values of  $B$  that are super-logarithmic and values of  $M$  that are at least a logarithmic factor larger than  $B$ , to achieve an I/O overhead (in terms of the number of messages exchanged between Alice and Bob) of  $O(\log^2 n / \log B)$ . That is, their method also can match the logarithmic lower bound of Goldreich and Ostrosfsky, but with a scheme that requires both  $M$  and  $B$  to be  $\Omega(n^\epsilon)$ , for a fixed constant  $0 < \epsilon \leq 1$ . Ohrimenko *et al.* [19] present

an oblivious storage (OS) scheme (which, as we observed, can also be used for ORAM simulation) that achieves an I/O overhead of  $O(1)$ , but it is not statistically secure and it requires  $M$  and  $B$  to be at least  $\Omega(n^\epsilon)$ .

Wang *et al.* [27] introduce an interesting “oblivious data structure” framework, which applies to bounded-degree data structures, such as search trees, to achieve an  $O(\log n)$  I/O overhead for data-structure access sequences. Their algorithms are based on (non-recursive) Path ORAM [25], however, which requires that  $M$  and  $B$  be super-logarithmic, and, even then, their method does not achieve an  $O(1)$  I/O overhead, even for larger values of  $B$  and  $M$ .

In addition, there is a growing literature on other ORAM and OS solutions, which is too large to review here (e.g., see [1, 7, 8, 11–13, 20–24, 26]). These results also optimize I/O overhead, but we are not aware of any previous results that beat the asymptotic I/O bounds for the Path ORAM scheme for a wide range of values of  $B$  and  $M$  while also achieving statistical security for the simulation method.

## 1.2 Our Results

We provide a method for ORAM simulation, which we call BIOS ORAM, that achieves statistical security and has efficient asymptotic I/O overheads for a wide range of values for the parameters  $B$  and  $M$ . In particular, we show how to perform an ORAM simulation of a polynomial number of accesses to an outsourced storage of size  $n$  with an I/O overhead that is  $O(\log^2 n / \log^2 B)$ , w.h.p., for  $B$  and  $M$  ranging from logarithmic to a fraction of  $n$ . For example, we can achieve the following specific bounds, depending on the values of  $B$  and  $M$ :

- When  $B$  and  $M$  are logarithmic or polylogarithmic in  $n$ , we achieve an I/O overhead that is  $O(\log^2 n / (\log \log n)^2)$ , w.h.p.
- When  $B$  and  $M$  are only  $\Omega(2^{\sqrt{\log n}})$ , we achieve an I/O overhead that is  $O(\log n)$ , w.h.p.
- When  $B$  and  $M$  are  $O(n^\epsilon)$ , for some constant  $0 < \epsilon \leq 1/2$ , we achieve an I/O overhead that is  $O(1)$ , w.h.p.

We summarize our results in Table 1, comparing them to some of best-known previous ORAM results. Note, for example, that our results apply to a wider range of values of the parameters  $B$  and  $M$  than the Path ORAM scheme [25] and improves the I/O overhead for ORAM simulation over this entire range. For example, the best I/O overhead that Path ORAM can achieve is  $O(\log n)$  even when  $B$  and  $M$  are  $O(n^\epsilon)$ , whereas our BIOS ORAM scheme achieves a constant I/O overhead in such scenarios. In addition, our I/O overhead bounds match those of the Melbourne shuffle for values of  $B$  that are  $\Theta(n^\epsilon)$  while also extending to values of  $B$  that are smaller than those possible using the Melbourne shuffle approach. For example, as mentioned above, if  $B$  and  $M$  are just  $\Omega(2^{\sqrt{\log n}})$ , then we achieve an I/O overhead of  $O(\log n)$ , w.h.p., which is a result that is not achievable using previous ORAM methods for such values of  $B$  and  $M$ .

Our methods are remarkably simple and make multiple uses of the ubiquitous B-tree data structure (e.g., see [4, 5, 16]), along with a reduction of ORAM simulations to isogrammic OS access sequences, as well as efficient ways of obliviously simulating isogrammic access sequences (again, using B-trees). In particular, we show how to implement an oblivious storage (OS) scheme for any isogrammic access sequence so as to achieve a simulation that achieves statistical security and has an I/O overhead that is  $O(\log n / \log B)$  with high probability. In addition, we show how to

apply this result to improve the I/O overhead for oblivious tree-structured data structures, which improves an oblivious data-structure bound of Wang *et al.* [27] and may be of independent interest.

## 2 An Overview of B-Trees

As is well-known in database circles, a B-tree is a multi-way search tree, which stores internal nodes as blocks so that its depth is  $O(\log_B n)$ , e.g., see [4, 5, 16]. In the B-trees we use in this paper, we choose a branching factor of

$$B' = B^{1/4},$$

where  $B$  is our message-size parameter. Such a B-tree supports searching and updates (insertions and deletions) in  $O(\log_{B'} n) = O(\log n / \log B') = O(\log n / \log B)$  I/Os of blocks of size  $B'$ . That is, each search or update involves accessing  $O(1)$  nodes on each level of the B-tree, in a root-to-leaf search followed (for updates) by a leaf-to-root set of updates, for which we refer the interested reader to known methods for searching and updating B-trees (e.g., see [4, 5, 16]). From the perspective of the server, Bob, the I/Os for searching a B-tree would simply look like Alice accessing  $O(\log n / \log B') = O(\log n / \log B)$  blocks of storage. (See Figure 1.)

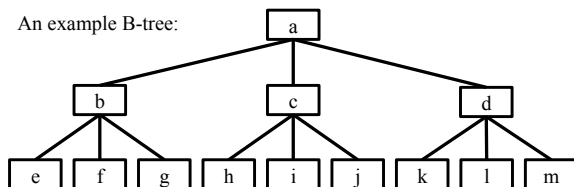

Figure 1: An example B-tree with branching factor 3. © 2017 Michael Goodrich. Used with permission.

## 3 B-Trees + Isogrammic OS = ORAM

In this section, we describe the first component of our *BIOS* ORAM scheme, which is a reduction of ORAM simulation to isogrammic OS, at the cost of increasing the I/O overhead of Alice’s accesses by a factor of  $O(\log n / \log B)$ . That is, we show how to transform an arbitrary sequence of read and write operations into an isogrammic sequence of `get` and `put` operations, with a blow-up in length of  $O(\log n / \log B)$ . By then showing how to obviously simulate an isogrammic access sequence with an I/O overhead of  $O(\log n / \log B)$ , we get the main result of this paper, that is, that we can achieve an ORAM scheme with an I/O overhead of  $O((\log n / \log B)^2)$ .

Suppose, then, that Alice’s RAM algorithm,  $\mathcal{A}$ , which she wishes to perform on her data outsourced to Bob, uses a memory of  $n$  cells indexed by integers in the range  $[0, n - 1]$ . Let  $R$  be a B-tree having each cell of Alice’s storage stored in a sub-block of size  $B' = B^{1/4}$  associated with a block at a leaf of  $R$  (ordered in the standard left-to-right fashion). Furthermore, let  $R$  have a branching factor of  $B' = B^{1/4}$ , so each internal node in  $R$  can be stored in a single sub-block of size  $B'$  and the depth of  $R$  is  $O(\log n / \log B') = O(\log n / \log B)$ . Intuitively, the main idea of our reduction is that, for each `write`( $i, v$ ) or `read`( $i$ ) operation in  $\mathcal{A}$ , we perform a search in  $R$  for the

index  $i$ , to find the sub-block containing memory cell,  $i$ , and then we replace this sub-block of size  $B'$  and all the nodes of size  $B'$  that we just traversed with new nodes.

Initially, we construct  $R$  in a bottom-up fashion so that each node  $u$  in  $R$  is assigned a random nonce,  $r_u$ , of  $\lceil \log n \rceil$  bits. For each leaf,  $u$ , of  $R$ , which is storing some block,  $V$ , of  $B$  values for the cells in Alice's storage for some set of indices,  $\{i, i + 1, \dots, i + B' - 1\}$ , we issue a  $\text{put}(k, v)$  operation, where  $k = (r_u, u)$  and  $v = (i, V)$ . In addition, we (obviously) store  $r_u$  at  $u$  in  $R$  on the server. Note that  $v$  fits in a single block of size  $B$ . For each internal node,  $u$ , of  $R$ , which we construct level-by-level, so that we can obviously read in the random nonce,  $r_{u_i}$ , associated with each child,  $u_i$ , of  $u$  in  $R$ , then we assign  $u$  a random nonce,  $r_u$ , and we issue a  $\text{put}(k, v)$  operation, where  $k = (r_u, u)$  and

$$v = (I, r_{u_1}, u_1, r_{u_2}, u_2, \dots, r_{u_{B'-1}}, u_{B'-1}),$$

where  $I$  is the block of key values needed to decide for any search which child,  $u_i$ , of  $u$  to access next. Note that  $v$  fits in  $O(1)$  sub-blocks of size  $B'$ . This initialization phase establishes the B-tree,  $R$ , in Bob's storage and issues  $O(n/B')$   $\text{put}$  operations that identify each node,  $u$ , of  $R$  using a key that comprises a random nonce,  $r_u$ , of  $\lceil \log n \rceil$  bits. We also keep a global variable, that maintains the random nonce for the root.

For each  $\text{read}(i)$  or  $\text{write}(i, v)$  operation after this initialization, we traverse a root-to-leaf path,  $\pi$ , in  $R$  to the leaf associated with the sub-block holding the cell  $i$ . This involves performing a sequence of  $O(\log n / \log B)$   $\text{get}(k)$  operations, where each  $k$  is a pair of a node name in  $R$  and the random nonce for that node. We cache the nodes returned by these  $\text{get}$  operations in Alice's private memory. Then, processing the nodes in  $\pi$  in reverse order, we give each node  $u$  in this sequence a new random nonce,  $r_u$ , and we issue a  $\text{put}(k, v)$  operation, where  $k = (r_u, u)$  and

$$v = (I, r_{u_1}, u_1, r_{u_2}, u_2, \dots, r_{u_{B'-1}}, u_{B'-1}),$$

where  $u_1, \dots, u_{B'-1}$  are the children of  $u$  in  $R$ . We do this processing in reverse order so that when we issue such a  $\text{put}(k, v)$  operation, we will have available the new random nonce for the child,  $u_j$ , of  $u$  that we previously processed as well as the old (and still unused) random nonces for the other children of  $u$ . In this case, the nodes are B-tree nodes, which are of size  $B^{1/4}$ , as we have defined this to be the branching factor for our B-tree. Fortunately, our message block size,  $B$ , is large enough to store up to  $B^{3/4}$  such nodes in a single message block.

Each  $\text{read}$  or  $\text{write}$  involves issuing  $O(\log n / \log B)$   $\text{get}$  and  $\text{put}$  operations; hence, this increases the total number of I/Os for Alice's access sequence by an  $O(\log n / \log B)$  factor. The important observation is that this process results an isogrammic access sequence, since each key used in a  $\text{put}(k, v)$  operation comprises a random nonce of at least  $\lceil \log n \rceil$  bits, each such key is not already in our set (since each key also comprises a unique node name), and each  $\text{get}(k)$  operation is guaranteed to match up with a previous  $\text{put}(k, v)$  operation. Thus, we have the following.

**Theorem 1.** *Given a RAM algorithm,  $\mathcal{A}$ , with memory size,  $n$ , we can simulate the memory accesses of  $\mathcal{A}$  using an isogrammic access sequence that initially creates  $O(n/B')$   $\text{put}$  operations and then creates  $O(\log n / \log B)$   $\text{get}$  and  $\text{put}$  operations for each step of  $\mathcal{A}$ . Each key used in a  $\text{get}$  or  $\text{put}$  operation comprises a random nonce of at least  $\lceil \log n \rceil$  bits and each value used in a  $\text{put}$  operation is a sub-block of size  $O(B')$  words.*

*Proof.* For the security claim, consider a simulation of the security game mentioned in the introduction, assuming the statistical security for our isogrammic OS. Suppose, then, that Bob

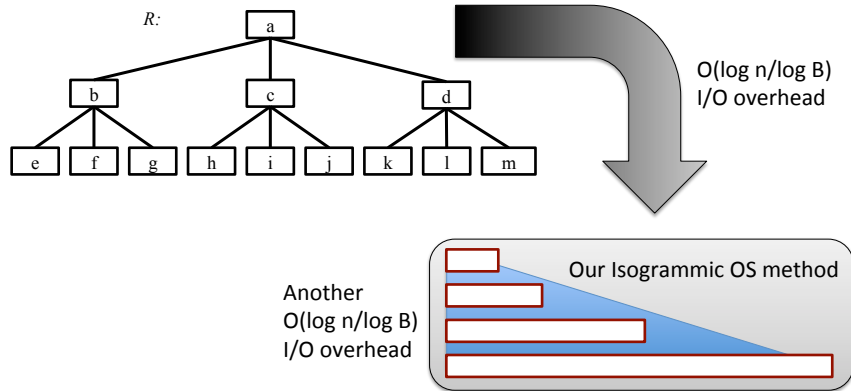

Figure 2: A high-level view of our BIOS ORAM scheme. © 2017 Michael Goodrich. Used with permission.

creates two access sequences,  $\sigma_1$  and  $\sigma_2$ , and gives them to Alice, who then chooses one at random and simulates it, as described above. For each access to a memory index,  $i$ , in the RAM simulation for her chosen  $\sigma_j$ , the memory cell for  $i$  is read and written to by doing a search in  $R$ . The important observation is that this access consists of  $O(\log n / \log B)$  accesses a root-to-leaf sequence of nodes of  $R$ , indexed by newly-generated independent random numbers each time. Thus, nothing is revealed to Bob about the index,  $i$ . That is, the number of accesses in Alice’s simulation is the same for  $\sigma_1$  and  $\sigma_2$ , and the sequence of keys used is completely independent of the choice of  $\sigma_1$  or  $\sigma_2$ . Thus, Bob is not able to determine which of these sequences she chose with probability better than  $1/2$ . □

As we show in the remainder of this paper, we can simulate an isogrammic access sequence obviously in a statistically secure manner with an I/O overhead that is  $O(\log n / \log B)$  with high probability. Combining this result with Theorem 1 gives us our claimed result that we can perform statistically-secure ORAM simulation with an I/O overhead that, with high probability, is  $O(\log^2 n / \log^2 B)$ . (See Figure 2.)

## 4 B-tree OS for Small Sets

In this section, we present an OS solution for small sets, that is, sets whose size,  $n$ , is  $O(B^{3/2})$ , and small items, that is, items whose size is  $O(B')$  words, where  $B' = B^{1/4}$ . This is admittedly a fairly restrictive scenario, but it nevertheless is a critical component of our isogrammic OS scheme. We show how, in this scenario, to use a B-tree to achieve statistical security for an OS simulation that works for general sequences of `put` and `get` operations, not just isogrammic sequences. That is, in this subsection, we allow for keys that are not necessarily random (so long as they are unique) and we allow `get(k)` operations to return “not found” responses.

Suppose, then, that we wish to support an oblivious storage (OS) for a set of items that can be as large as  $n = \Theta(B^{3/2})$ . In this case, we utilize a B-tree,  $F$ , with branching factor,  $B' = B^{1/4}$ , so its height is  $O(\log n / \log B') = O(\log n / \log B) = O(1)$ , since we are restricting ourselves here to sets of size at most  $O(B^{3/2})$  and items of size  $O(B')$ . Put another way, our restriction on the set size,  $n$ , implies that  $B$  is  $\Omega(n^{2/3})$  and  $B'$  is  $\Omega(n^{1/6})$ , that is, that  $B$  is  $\Omega(B^{1/4}n^{1/2})$ .



Our small-set B-tree OS method is a modification and adaptation of the “ $\sqrt{n}$ ” solution of Damgård *et al.* [6] to B-trees and the OS setting. Let  $F$  be our B-tree with capacity  $n$  and branching factor  $B'$ ; hence,  $F$  has depth  $D = 4\lceil \log n / \log B \rceil$ , with  $n$  items stored in its leaves, and randomly shuffled in an array of Bob’s storage of size  $O(nB')$  memory words. Initially, we construct  $F$  using an initial set of items, which could even be empty. We pad the nodes of  $F$  with empty dummy nodes, as necessary, to make every node of  $F$  have the same depth,  $D$ . An internal B-tree node consists of  $B'$  keys; hence, a single message block can fit  $B^{3/4}$  B-tree nodes or items (since items are also of size  $B'$  here), that is,  $\Omega(n^{1/2})$  B-tree nodes or items. In addition, we also store a singly linked list,  $\ell$ , of  $D\lceil \sqrt{n} \rceil$  nodes, which are the same size as B-tree nodes and items and are randomly shuffled in with the B-tree nodes of  $F$ .

We can initialize  $F$  in this way using the oblivious shuffling method of Goodrich and Mitzenmacher [10]. In this context, where we are obviously sorting nodes and items that are themselves of size  $B'$ , their method involves a multi-way merging of sorted lists with a branching factor of  $(M/B')^{1/3} = \Theta(n^{1/6})$ , where the merging step involves a simple oblivious scanning of each of these arrays. The merge in their method requires, in this context (where we are merging nodes and items of size  $B' = \Theta(n^{1/6})$ ) that there be

$$\Omega((M/B')^{2/3}B' + (M/B')^{1/3}(B')^2)$$

values stored in memory at any given time, which we can bound as  $\Omega(n^{1/2})$  using the fact that, in this case,

$$(M/B')^{2/3}B' + (M/B')^{1/3}(B')^2$$

is at least  $(n^{1/2})^{2/3}n^{1/6} + (n^{1/2})^{1/3}n^{1/3}$ , which equals  $2n^{1/2}$ . Thus, we can scan each of the  $\Theta(n^{1/6})$  sorted lists by reading  $\Theta(n^{1/2})$  elements from each sorted list at a time (and stopping the recursion when we reach lists of this size). This means that the total number of I/Os needed for this oblivious shuffling is  $O((n/n^{1/2}) \log_{M/B'}^2(n/B'))$  I/Os. Given our other assumptions about  $B$  and  $M$ , this shuffling therefore requires at most  $O(n^{1/2})$  I/Os. In addition, we maintain  $D$  caches,  $C_1, \dots, C_D$ , of size  $B'\sqrt{n}$  each, one for each level of  $F$ . Thus, each cache can be read or written in  $O(1)$  I/Os.

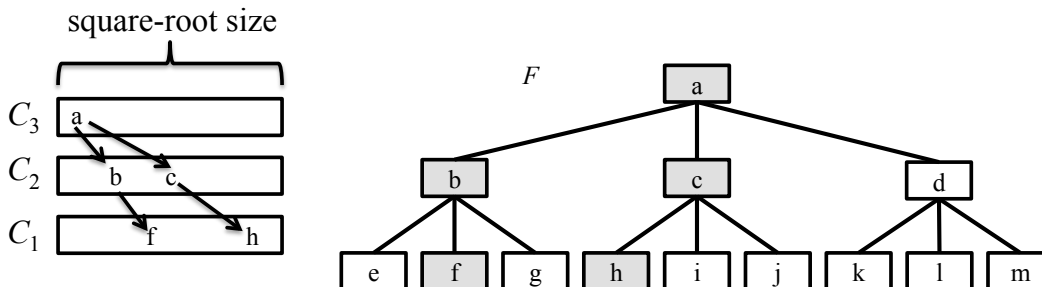

Figure 3: A B-tree,  $F$ , and a hierarchy of  $\Theta(\log n / \log B)$  caches,  $C_1, C_2, \dots$ . We shade the nodes that have been accessed previously in grey. Each cache is associated with a specific level of  $F$ . © 2017 Michael Goodrich. Used with permission.

Let us consider each type of access, with the design of making it impossible for Bob to determine even if we are performing a  $\text{get}(k)$  or  $\text{put}(k, v)$  operation. In either a  $\text{get}(k)$  or  $\text{put}(k, v)$  operation, we begin

with a search for the key  $k$  in  $F$ . To perform such a search in  $F$ , we read each of the nodes in a path,  $\pi$ , from the root of  $F$  to the leaf containing our search key,  $k$ , or its predecessor (if  $k$  is not in our set,  $S$ ). For each level,  $i$ , of  $F$  during this search, we first read (as one I/O), the cache,  $C_i$ , to see if the  $i$ -th node,  $v_i$ , of  $\pi$  is in  $C_i$ . If  $v_i$  is in  $C_i$ , then we examine it and determine the location of the next node,  $v_{i+1}$ , in  $\pi$ , and we read the next dummy node in  $\ell$  (for the sake of obliviousness, since the location of this dummy node looks random to Bob and has not been previously accessed). If  $v_i$  is not in  $C_i$ , then we read it in (this is the first time we are accessing  $v_i$  and this location looks to Bob to be random). We note that each such node is of size  $B'$ ; hence, it and each cache can be read or written in  $O(1)$  I/Os. (See Figure 3.)

After we have completed the reading of all the nodes in  $\pi$ , we can perform any updating as necessary for these nodes so as to perform the functionality of our  $\text{get}(k)$  or  $\text{put}(k, v)$  operation. Without going into details (e.g., see [4, 5, 16]), either of these operations will either involve no structural changes to  $F$  or will involve our adding  $O(1)$  nodes per level of  $F$ . Let  $\pi'$  denote the set of updated nodes in  $F$  (which we can determine using Alice's private memory). Note that each internal node of  $F$  in  $\pi'$  will include pointers to existing nodes in  $F$ , but these have not yet been accessed yet and we have not revealed any information about them to Bob. We then write the nodes of  $\pi'$  out to Bob's storage, placing each node,  $v_i$ , on level of  $i$  of  $\pi$ , in the cache,  $C_i$ , using  $O(1)$  I/Os for each level of  $F$ . In fact, we pad this set so that we always write the same number of  $O(1)$  nodes to each  $C_i$ , based on standard update rules for B-trees (e.g., see [4, 5, 16]). We perform this process in a bottom-up leaf-to-root fashion, so that we can inductively always be able to know the locations for the child nodes for any node in  $F$  (even if that node is in a cache and some of its children are in the lower-level cache). Thus, we can determine the locations in Bob's storage for any root-to-leaf path in  $F$  by reading the nodes and caches in Bob's storage sequentially starting from the root. After we have completed  $\lceil \sqrt{n} \rceil$  accesses of  $F$  in this manner, we rebuild and reshuffle  $F$  and a new linked list,  $\ell$ , and repeat this B-tree access procedure. This rebuilding and reshuffling requires  $O(n^{1/2})$  I/Os, as described above. Thus, we have the following.

**Theorem 2.** *Suppose we have a set,  $S$ , of up to  $n$  items, where each item is of size at most  $B'$ , where  $B' = B^{1/4}$ , and  $n$  is  $O(B^{3/2})$ . Then our B-tree OS solution can implement an oblivious storage for  $S$  that has an I/O overhead of  $O(\log n / \log B) = O(1)$ , with high probability. This simulation is statistically secure, even for non-isogrammic access sequences.*

*Proof.* With respect to the security of this method, note that each access involves a search of all the caches of size  $\sqrt{n}$  and an access to a distinct random location (which is either a real node or a dummy node that Bob cannot tell apart) for each level of a shuffled B-tree,  $F$ , which was shuffled obliviously and has every possible permutation of its nodes on that level as being equally likely. We then access each cache for every level of  $F$  in a bottom-up fashion. Moreover, both the top-down and bottom-up phases of this computation involve the same form of access irrespective of whether we are performing a  $\text{get}$  or  $\text{put}$  operation. Thus, the adversary, Bob, can learn nothing about Alice's access sequence based on observing her access pattern. That is, in terms of the security game, Bob is unable to distinguish between two access sequences,  $\sigma_1$  and  $\sigma_2$ , of length  $N$  for sets of up to  $n$  items.

Since  $D$  is  $O(\log n / \log B)$ , and  $B$  is large enough for us to read an entire cache with one I/O, it is easy to see that each access in this simulation requires  $O(\log n / \log B) = O(1)$  I/Os. In addition, after we have performed  $O(\sqrt{n})$  such accesses, we do a rebuilding action that requires  $O(n^{1/2})$  I/Os; hence, this adds an amortized  $O(1)$  number of I/Os for each of the previous  $O(\sqrt{n})$  accesses. Thus,

the total I/O overhead is  $O(\log n / \log B) = O(1)$ , with high probability (where this probability is dependent only on the algorithm we use for oblivious shuffling, e.g., see [10]).  $\square$

This solution is a crucial component of our general isogrammic OS solution, which we describe next.

## 5 Isogrammic Oblivious Storage

In this section, we describe our isogrammic OS scheme, which is able to obfuscate any isogrammic access sequence with statistical security, achieving an I/O overhead that is  $O(\log n / \log B)$  with high probability. Our construction involves yet another use of B-trees, as a primary search structure, as well as repeated uses of our B-tree OS for small sets from Section 4.

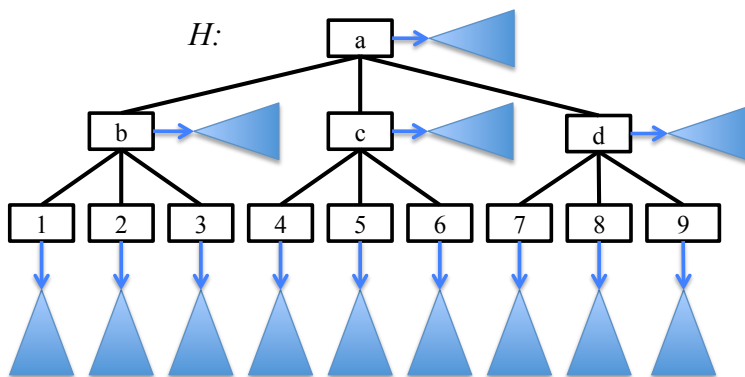

Figure 4: An illustration of our isogrammic OS. The B-tree tree,  $H$ , is shown in black. Each bucket, which implements our B-tree OS for small sets, is shown as a blue triangle. That is, each triangle represents a bucket of up to  $B^{3/2}$  items, which are accessed according to our B-tree OS method of Section 4. © 2017 Michael Goodrich. Used with permission.

Let  $n$  be the size of a set for which we wish to support an oblivious storage (OS), and let  $H$  be a static B-tree of height  $O(\log n / \log B)$  with branching factor  $B' = B^{1/4}$ , such that  $H$  has  $n/B$  leaves. For every node,  $u$  in  $H$ , including both the internal nodes and leaves, we store a “bucket,”  $b_u$ , which maintains an instance of our B-tree OS, as described above in Section 4, and let each such bucket have capacity  $4L$ , where  $L = B^{3/2}$ , except for leaves, which each have capacity  $8L$ . These buckets are used to store  $(k, v)$  items that are in the current set, i.e., items for which we have processed a  $\text{put}(k, v)$  operation and have yet to perform a  $\text{get}(k)$  operation. See Figure 4.

Recall that in an isogrammic access sequence we are given a sequence of  $\text{put}(k, v)$  and  $\text{get}(k)$  such that  $\text{get}(k)$  operations always have an item to return (i.e., there is a previous matching  $\text{put}(k, v)$  operation) and  $\text{put}(k, v)$  operations never try to insert an item whose key matches the key of an existing item. More importantly, every key contains a random nonce component of at least  $\lceil \log n \rceil$  bits. We use these random nonces as the addresses for where items should go in  $H$ . Namely, we maintain the following invariant throughout our OS simulation:

- For each item,  $(k, v)$ , in our current set of items,  $(k, v)$  is stored in exactly one bucket,  $b_u$ , for a node,  $u$ , on the root-to-leaf search path in  $H$  for the random part of  $k$ .

Given this invariant, let us describe how we process `put` and `get` operations.

For a `put( $k, v$ )` operation, we add  $(k, v)$  to the bucket,  $b_r$ , for the root,  $r$ , of  $H$ , using the B-tree OS method described in Section 4. Note that this satisfies our invariant for storing items in  $H$ , that is, storing an item in bucket for the root implies that it is stored in the root-to-leaf search path for the random part of its key. (We will describe later what we do when the root bucket becomes full, but that too will satisfy our invariant.) Then, for the sake of obliviousness (so Bob cannot tell whether this operation is a `get` or `put`), we uniformly and independently choose a random key,  $k'$ , and traverse the root-to-leaf path in  $H$  for  $k'$ , performing a search for  $k'$  in the bucket,  $b_u$ , for each node  $u$  on this path, using the B-tree OS method described in Section 4. Alice just “throws away” the results of these searches, but, of course, Bob doesn’t know this.

For any given `get( $k$ )` operation, we begin, for the sake of obliviousness, by inserting a dummy item,  $(k', e)$ , in the bucket,  $b_r$ , for the root,  $r$ , of  $H$ , where  $e$  is a special “empty” value (that nevertheless has the same size as any other value) and  $k'$  is a random key, using the fusion-tree OS method described in Section 4. So as to distinguish this type of dummy item from others, we refer to each such dummy item as an *original* dummy item. We then traverse the root-to-leaf path,  $\pi$ , for (the random part of)  $k$  in  $H$ , and, for each node,  $u$ , in  $\pi$ , we search in the bucket,  $b_u$ , for  $u$ , to see if the key-value pair for  $k$  is in this bucket, using the B-tree OS scheme described above in Section 4. By our invariant, the item,  $(k, v)$ , must be stored in the bucket for one of the nodes in the path  $\pi$ . Note that we search in the bucket for every node in  $\pi$ , even after we have found and removed the key-value pair,  $(k, v)$ . Because we are simulating an isogrammic access sequence, there will be one bucket with this item, but we search all the buckets for the sake of obliviousness.

An important consequence of the above methods and the fact that we are simulating an isogrammic access sequence is that each traversal of a path in  $H$  is determined by a random nonce that is chosen uniformly at random and is independent of every other nonce used to do a search in  $H$ . Thus, the server, Bob, learns nothing about Alice’s access pattern from these searches. In addition, as we will see shortly, the server cannot determine where any item,  $(k, v)$ , is actually stored, because the random part of the key  $k$  is only revealed when we do a `get( $k$ )` operation and `put` operations never reveal the locations of their keys. Moreover, we maintain the fact that the server doesn’t know the actual location of any item, along with our invariant, even as bucket for a node,  $u$ , becomes full and needs to have its items distributed to its children.

Periodically, so as to avoid overflowing buckets, we move items from a bucket,  $b_u$ , stored at a node  $u$  in  $H$  to  $u$ ’s children, in a process we call a *flush* operation. In particular, we flush the root node,  $r$ , every  $L$  `put` or `get` operations. We flush each internal node,  $u$ , after  $u$  has received  $B'$  flushes from its parent, which each involve inserting exactly  $4L/B'$  real and dummy items (including new dummy items) into the bucket for  $u$ . Because of this functionality, and the fact that we are moving items based on random keys, the number of real and original dummy items in the bucket,  $b_u$ , at a time when we are flushing a node  $u$  at depth  $i$  is expected to be  $L$ , and we maintain it to be at most  $4L$ . Also, note that we will periodically perform flush operations across all the nodes on a given level of  $H$  at any given time when flush operations occur, which is the main reason why our I/O overhead bounds are amortized. We don’t flush the leaf nodes in  $H$ , however. Instead, after every leaf,  $u$ , in  $H$  has received  $B'$  flushes, we perform an oblivious compression to compress out a sufficient number of dummy items so that the number of real and dummy items in  $u$ ’s bucket is  $4L$ . Thus, the bucket for a leaf never grows to have more than  $8L$  real and dummy items. If, at the time we are compressing the contents of a leaf bucket, we determine that there are more than  $4L$  real items being stored in such a bucket, which, as we show, is an event that occurs with low

probability, then we restart the entire OS simulation. Such an event doesn't compromise privacy, since it depends only on random keys, not Alice's data or access sequence. Thus, doing a restart just impacts performance, but because restarts are so improbable, our I/O bounds still hold with high probability.

At a high-level, our method for doing a flush operation at a node,  $u$ , in  $H$  has a similar structure to an analogous operation in the Path ORAM scheme [25], as well as in the paper mentioned above that is currently under submission for ORAM simulation when  $B$  and  $M$  are both very small. The details for our flush operation here are different than both of these works, however, in that our flush method depends crucially on the B-tree OS method of Section 4.

1. We obliviously shuffle the real and original dummy items of  $b_u$  into an array,  $A$ , of size  $4L$ , stored at the server. This step will never overflow  $A$  (because of how we perform the rest of the steps in a flush operation). This step can be done using known oblivious shuffling methods (e.g., see [10]), which add just a constant I/O overhead factor.
2. For each child,  $x_i$ ,  $i = 1, 2, \dots, B'$ , of  $u$ , we create an array,  $A_i$ , of size  $4L/B'$ .
3. We obliviously sort the real and original dummy items from  $A$  into the arrays,  $A_1, \dots, A_\ell$ , according to the keys for these items, so that the item,  $(k, v)$ , goes to the array  $A_i$  if the next  $O(\log B')$  bits of the random part of key  $k$  would direct a search for  $k$  to the child  $x_i$ . We perform this oblivious sorting step so that if there are fewer than  $4L/B'$  items destined for any array,  $A_i$ , we pad the array with (new) dummy items to bring the number of items destined to each array,  $A_i$ , to be exactly  $4L/B'$ . However, if we determine from this oblivious sorting step that there are more than  $4L/B'$  real and original dummy items destined for any array,  $A_i$ , which (as we show) is an event that occurs with low probability, then we restart the entire OS simulation. Because this step is done obliviously and search keys are random (hence, they never depend on Alice's data values or access pattern), even if we restart, Bob learns nothing about Alice's access sequence during this step. So, let us assume that we don't restart. This step can be done using known oblivious sorting, padding, and partitioning methods (e.g., see [10]), which add only a constant I/O overhead factor.
4. For each real and dummy item (including both original and new dummy items),  $(k, v)$ , in each  $A_i$ , we insert  $(k, v)$  into the bucket  $b_{x_i}$  using the B-tree OS method of Section 4. This method works only for small sets, but, of course, the number of items in each bucket determines such a small set.

The first important thing to note about a flush operation is that it is guaranteed to preserve our invariant that each item,  $(k, v)$ , is stored in the bucket of a node in  $H$  on the root-to-leaf path determined by the random part of  $k$ . Moreover, because we move real and original dummy items to children nodes obliviously, in spite of our invariant, the server never knows where an item,  $(k, v)$ , is stored; hence, the server can never differentiate two access sequences more than at random.

Let us analyze the complexity of a flush operation. Since we flush the root every  $L$  steps, and we flush every other node,  $u$ , at depth  $i$ , after it has received  $B'$  flushes, and both real and original dummy items are mapped to  $u$  only if the first  $i \log B'$  bits of each of their random keys matches  $u$ 's address, the expected number of real and original dummy items stored in the bucket for  $u$  is at most  $L$  at the time we flush  $u$ . In fact, this is a rather conservative estimate, since it assumes that none of these items were removed as a result of `get` operations. More importantly, we have the following.

**Lemma 3.** *The number,  $f$ , of real and original dummy items flushed from a node,  $u$ , to one of its children,  $x_i$ , is never more than  $4L/B'$ , with high probability. Likewise, a leaf in  $H$  will never receive more than  $4L$  real items, with high probability.*

*Proof.* The expected value of  $f$ , which can be expressed as a sum of independent indicator random variables, is at most

$$L/B' = B^{3/2-1/4} = B^{5/4} \geq d \log^{5/4} n,$$

for a constant,  $d \geq 3$ , since we are assuming that  $B$  is  $\Omega(\log n)$ . Thus, by a Chernoff bound (e.g., see [18]),

$$\Pr(f \geq 4L/B') \leq e^{-L/B} \leq e^{-d \log^{5/4} n} \leq n^{-3 \log^{1/4} n}.$$

The probability bound argument for a leaf in  $H$  is similar. The lemma follows, then, by a union bound across all nodes of  $H$  and the polynomial length of access sequences.  $\square$

Thus, with high probability, we never need to do a restart as a result of a potential overflow during a flush operation.

**Theorem 4.** *We can obviously simulate an isogrammic sequence of a polynomial number of  $\text{put}(k, v)$  and  $\text{get}(k)$  operations, for a data set of size  $n$ , with an I/O overhead of  $O(\log n / \log B)$ , with high probability. Moreover, this simulation is statistically secure.*

*Proof.* The height of the tree,  $H$ , is  $O(\log n / \log B)$ . Thus, by Theorem 2, with high probability, the I/O overhead is proportional to a constant times  $O(\log n / \log B)$ , which is itself  $O(\log n / \log B)$ . For the security claim, consider an instance of the simulation game, where Bob chooses two isogrammic access sequences,  $\sigma_1$  and  $\sigma_2$ , of length  $N$  for a key set of size  $n$ , and gives them to Alice, who then chooses one uniformly at random and simulates it according to the isogrammic OS scheme. Each access that she does involves accessing a sequence of nodes of  $H$  determined by random keys and for each node doing a lookup in an OS scheme that is itself statistically secure, by Theorem 2. In addition,  $\text{put}$  operations add items at the top bucket and are obfuscated with data-oblivious flush operations. Therefore, Bob is not able to distinguish between  $\sigma_1$  and  $\sigma_2$  any better than at random.  $\square$

## 6 Our BIOS ORAM Algorithm

Putting the above pieces together, then, gives us the following theorem, which is the main result of this paper.

**Theorem 5.** *Given a RAM algorithm,  $\mathcal{A}$ , with memory size,  $n$ , where  $n$  is a power of 2, we can simulate the memory accesses of  $\mathcal{A}$  in an oblivious fashion that achieves statistical security, such that, with high probability, the I/O overhead is  $O(\log^2 n / \log^2 B)$  for a client-side private memory of size  $M \geq B$  and messages of size  $B \geq 3 \log n$ .*

*Proof.* By Theorem 1, each access in  $\mathcal{A}$  gets expanded into  $O(\log n / \log B)$  operations in an isogrammic access sequence, and, with high probability, each such operation has an overhead of  $O(\log n / \log B)$ , by Theorem 4. The security claim follows from the security claims of Theorems 1 and 4.  $\square$

## 7 Isogrammic Algorithm Design

In this section, we study the expressive power of the isogrammic access sequences, showing that it subsumes some previous specialized design patterns for implementing algorithms in the cloud in a privacy-preserving way. Thus, by Theorem 4, any algorithm designed in this framework, to give rise to an isogrammic access sequence, can be simulated in an oblivious fashion to have an I/O overhead that is  $O(\log n / \log B)$ , with high probability.

There are a number of previous algorithm-engineering design paradigms that can facilitate privacy-preserving data access in the cloud, which, as we show, can be reduced to isogrammic access sequences at only a constant cost per operation. Thus, the observations made in this section may be of independent interest for these specialized applications.

### 7.1 Simulating Oblivious Data Structures

The first application we explore is for bounded-degree directed data structures in the *oblivious data structure* framework of Wang *et al.* [27]. This framework applies to any data structure that has a small number of “root” nodes for tree structures with bounded out-degree, such that updates and accesses are done as a sequence of linked nodes starting from a root. Using a heuristic similar to that used by Wang *et al.* [27], we can make any such access sequence isogrammic. Namely, let us keep a random nonce,  $r_u$ , of  $\lceil \log n \rceil$  bits for each node,  $u$ , in our data structure, and let us assign the key for accessing a node  $u$  to be the pair,  $(r_u, u)$ . That is, any other node that points to  $u$  will identify  $u$  using the pair  $(r_u, u)$ . The important observation is that any access sequence can inductively be able to access nodes with their nonces, because bounded-degree data structures are accessed starting from a root node; hence, any set of node updates performs its operations on a path from a root and we can update each node on such a path in reverse order to have its new random nonce. More importantly, for each node,  $x$ , that points to node  $u$ , we can also update  $x$  to change its pointer to  $u$  to have  $u$ ’s new nonce. Using such nonces as keys, therefore, gives rise to an isogrammic access sequence; hence, our result from Theorem 4 applies to such scenarios. This implies the existence of efficient oblivious simulations for access sequences involving stacks, queues, and dequeues (which have just  $\Theta(1)$  node updates per operation), as well as binary trees, such as AVL trees and red-black trees (whose updates and searches can be padded to have  $\Theta(\log n)$  node updates per operation). We summarize as follows.

**Theorem 6.** *Any algorithm,  $A$ , written in the oblivious data structure framework, with bounded-degree tree nodes reachable from a constant number of “root” nodes, can be implemented as an algorithm,  $A'$ , in the isogrammic algorithm design paradigm such that each data access in  $A$  is translated into  $O(1)$  accesses in  $A'$ .*

For example, we can create an isogrammic queue,  $Q$ , by using an array,  $A$ , of size  $n$  and a dummy array,  $B$ , of size  $n$ , together with three global “root” indices, front, rear, and dummy. Each time we access  $Q$ , for an enqueue, dequeue, or no-op operation, we read the front, rear, and dummy variables. If this is a no-op operation (or this would be an error operation, like doing a dequeue from an empty queue), then we next read the next dummy slot in  $B$  and we increment the dummy variable. If this is a valid enqueue, then we increment rear and add the new element to that location in  $A$ . If this is a valid dequeue, then we increment front and read the element from the previous front location in  $A$ . Anytime we wrap around  $A$  or  $B$ , we increment a version counter

(associated with the global variables), so that we access the cells in  $A$  or  $B$  by index and version counter. This implies that we always access the queue using an isogrammic access sequence.

## 7.2 Compressed Scanning

In addition, the *compressed-scanning* paradigm [14,15] also falls into our framework for isogrammic access sequences. A compressed-scanning algorithm consists of  $t$  rounds, where each round involves accessing each of the elements of a set,  $S$ , of  $n$  data items exactly once in a read-compute-write operation. By introducing random nonces and assigning them to items for each round, we can easily transform any algorithm in the compressed-scanning model into an isogrammic access sequence. Thus, all of the graph algorithms presented in these papers [14,15] can be simulated obliviously with our isogrammic OS scheme. We summarize as follows.

**Theorem 7.** *Any algorithm,  $A$ , written in the compressed-scanning framework can be implemented as an algorithm,  $A'$ , in the isogrammic algorithm design paradigm such that each data access in  $A$  is translated into  $O(1)$  accesses in  $A'$ .*

## 8 Conclusion

In this paper we have shown how to improve the I/O overhead for statistically secure ORAM simulation for a wide range of parameterized values for the client-side private memory size,  $M$ , and the size,  $B$ , of message blocks. Our results imply I/O overhead bounds that range from  $O(1)$  to  $O(\log^2 n / (\log \log n)^2)$ , with high probability. For example, we can achieve an I/O overhead of  $O(\log n)$ , with high probability, for statistically secure ORAM simulation if  $B$  and  $M$  are at least  $\Omega(2^{\sqrt{\log n}})$ , which is asymptotically smaller than  $n^\epsilon$ , for any constant  $0 < \epsilon \leq 1$ .

For future work, it would be interesting to see if there is a super-logarithmic lower bound for the I/O overhead for ORAM simulation for cases when  $B$  and  $M$  are small. Also, it would be interesting to see if it is possible to achieve an I/O overhead for statistically secure ORAM simulation that is  $O(\log n)$  when  $B$  and  $M$  are  $o(2^{\sqrt{\log n}})$ , i.e., asymptotically smaller than  $2^{\sqrt{\log n}}$ .

## Acknowledgments

This research was supported in part by the National Science Foundation under grant 1228639. This article also reports on work supported by the Defense Advanced Research Projects Agency (DARPA) under agreement no. AFRL FA8750-15-2-0092. The views expressed are those of the authors and do not reflect the official policy or position of the Department of Defense or the U.S. Government. We would like to thank Eli Upfal and Marina Blanton for helpful discussions regarding the topics of this paper.

## References

- [1] D. Apon, J. Katz, E. Shi, and A. Thiruvengadam. Verifiable oblivious storage. In *17th Int. Conf. on Practice and Theory in Public-Key Cryptography (PKC)*, volume 8383 of *LNCS*, pages 131–148. Springer, 2014.



- [2] D. Boneh, D. Mazières, and R. A. Popa. Remote oblivious storage: Making oblivious RAM practical. Technical report, MIT CSAIL, 2011.  
<http://dspace.mit.edu/handle/1721.1/62006>.
- [3] K.-M. Chung, Z. Liu, and R. Pass. Statistically-secure ORAM with  $\tilde{O}(\log^2 n)$  overhead. In *20th ASIACRYPT*, pages 62–81, 2014.
- [4] D. Comer. Ubiquitous B-tree. *ACM Comput. Surv.*, 11(2):121–137, June 1979.
- [5] T. H. Cormen, C. E. Leiserson, R. L. Rivest, and C. Stein. *Introduction to Algorithms*. The MIT Press, 3rd edition, 2009.
- [6] I. Damgård, S. Meldgaard, and J. B. Nielsen. Perfectly secure oblivious RAM without random oracles. In *8th Theory of Cryptography Conference (TCC)*, volume 6597 of *LNCS*, pages 144–163. Springer, 2011.
- [7] S. Devadas, M. Dijk, C. W. Fletcher, L. Ren, E. Shi, and D. Wichs. Onion ORAM: A constant bandwidth blowup oblivious RAM. In *13th Int. Conf. on Theory of Cryptography (TCC)*, volume 9563 of *LNCS*, pages 145–174. Springer, 2016.
- [8] C. Gentry, K. A. Goldman, S. Halevi, C. Julta, M. Raykova, and D. Wichs. Optimizing ORAM and using it efficiently for secure computation. In *13th Int. Symp. on Privacy Enhancing Technologies (PETS)*, pages 1–18. Springer, 2013.
- [9] O. Goldreich and R. Ostrovsky. Software protection and simulation on oblivious RAMs. *J. ACM*, 43(3):431–473, May 1996.
- [10] M. T. Goodrich and M. Mitzenmacher. Privacy-preserving access of outsourced data via oblivious RAM simulation. In *28th Int. Colloq. on Automata, Languages and Programming (ICALP)*, volume 6756 of *LNCS*, pages 576–587. Springer, 2011.
- [11] M. T. Goodrich, M. Mitzenmacher, O. Ohrimenko, and R. Tamassia. Oblivious RAM simulation with efficient worst-case access overhead. In *3rd Cloud Computing Security Workshop*, pages 95–100, 2011.
- [12] M. T. Goodrich, M. Mitzenmacher, O. Ohrimenko, and R. Tamassia. Practical oblivious storage. In *2nd ACM Conf. on Data and Application Security and Privacy (CODASPY)*, pages 13–24, 2012.
- [13] M. T. Goodrich, M. Mitzenmacher, O. Ohrimenko, and R. Tamassia. Privacy-preserving group data access via stateless oblivious RAM simulation. In *23rd ACM-SIAM Symposium on Discrete Algorithms (SODA)*, pages 157–167, 2012.
- [14] M. T. Goodrich, O. Ohrimenko, and R. Tamassia. Graph drawing in the cloud: Privately visualizing relational data using small working storage. In *20th Int. Symp. on Graph Drawing (GD)*, volume 7704 of *LNCS*, pages 43–54. Springer, 2013.
- [15] M. T. Goodrich and J. A. Simons. Data-oblivious graph algorithms in outsourced external memory. In *8th Int. Conf. on Combinatorial Optimization and Applications (COCOA)*, volume 8881 of *LNCS*, pages 241–257. Springer, 2014.

- [16] M. T. Goodrich and R. Tamassia. *Algorithm Design and Applications*. Wiley Publishing, 1st edition, 2014.
- [17] E. Kushilevitz, S. Lu, and R. Ostrovsky. On the (in)security of hash-based oblivious RAM and a new balancing scheme. In *23rd ACM-SIAM Symposium on Discrete Algorithms (SODA)*, pages 143–156, 2012.
- [18] M. Mitzenmacher and E. Upfal. *Probability and computing: Randomized algorithms and probabilistic analysis*. Cambridge University Press, 2005.
- [19] O. Ohrimenko, M. T. Goodrich, R. Tamassia, and E. Upfal. The Melbourne shuffle: Improving oblivious storage in the cloud. In *Int. Colloq. on Automata, Languages, and Programming (ICALP)*, volume 8573 of *LNCS*, pages 556–567. Springer, 2014.
- [20] L. Ren, C. W. Fletcher, A. Kwon, E. Stefanov, E. Shi, M. van Dijk, and S. Devadas. Ring ORAM: Closing the gap between small and large client storage oblivious RAM, 2014. Cryptology ePrint Archive, Report 2014/997, <http://eprint.iacr.org/>.
- [21] L. Ren, X. Yu, C. W. Fletcher, M. van Dijk, and S. Devadas. Design space exploration and optimization of path oblivious RAM in secure processors. In *40th ACM Int. Symp. on Computer Architecture (ISCA)*, pages 571–582, 2013.
- [22] E. Shi, T.-H. H. Chan, E. Stefanov, and M. Li. Oblivious RAM with  $O((\log N)^3)$  worst-case cost. In *17th Int. Conf. on the Theory and Application of Cryptology and Information Security (ASIACRYPT)*, volume 7073 of *LNCS*, pages 197–214. Springer, 2011.
- [23] E. Stefanov and E. Shi. Multi-cloud oblivious storage. In *2013 ACM Conf. on Computer and Communications Security (CCS)*, pages 247–258, 2013.
- [24] E. Stefanov and E. Shi. ObliviStore: High performance oblivious cloud storage. In *IEEE Symp. on Security and Privacy (SP)*, pages 253–267, May 2013.
- [25] E. Stefanov, M. van Dijk, E. Shi, C. Fletcher, L. Ren, X. Yu, and S. Devadas. Path ORAM: An extremely simple oblivious RAM protocol. In *ACM Conf. on Computer and Communications Security (CCS)*, pages 299–310, 2013.
- [26] X. Wang, H. Chan, and E. Shi. Circuit ORAM: On tightness of the Goldreich-Ostrovsky lower bound. In *22nd ACM Conf. on Computer and Communications Security (CCS)*, pages 850–861, 2015.
- [27] X. S. Wang, K. Nayak, C. Liu, T.-H. H. Chan, E. Shi, E. Stefanov, and Y. Huang. Oblivious data structures. In *ACM Conf. on Computer and Communications Security (CCS)*, pages 215–226, 2014.