

Starvation Freedom in Multi-Version Transactional Memory Systems *

Ved Prakash Chaudhary ^{†1}, Chirag Juyal¹, Sandeep Kulkarni², Sweta Kumari¹, and Sathya Peri^{‡1}

¹Department of Computer Science & Engineering, IIT Hyderabad, India ,
{cs14mtech11019, cs17mtech11014, cs15resch01004,
sathya.p}@iiith.ac.in

²Department of Computer Science, Michigan State University, USA,
sandeep@cse.msu.edu

Abstract

Software Transactional Memory systems (STMs) have garnered significant interest as an elegant alternative for addressing synchronization and concurrency issues with multi-threaded programming in multi-core systems. For STMs to be efficient, they must guarantee some progress properties. This work explores the notion of starvation-freedom in STMs. An STM system is said to be starvation-free if every thread invoking a transaction gets the opportunity to take a step (due to the presence of a fair scheduler) then the transaction will eventually commit.

A few starvation-free algorithms have been proposed in the literature in the context of single-version STM Systems. These algorithm work by priority. If two transactions conflict, then the transaction with lower priority will abort. A transaction running for a long time will eventually have the highest priority and hence commit. But the drawback with this approach is that if a set of high-priority transactions become slow, then they can cause several other transactions to abort. In that case, this approach becomes similar to pessimistic lock-based approach.

Multi-version STMs maintain multiple-versions for each transactional object or t-object. By storing multiple versions, these systems can achieve greater concurrency. In this paper, we propose multi-version starvation free STM, KSFTM, which as the name suggests achieves starvation freedom while storing K versions of each t-object. Here K is an input parameter fixed by the application programmer depending on the requirement. Our algorithm is dynamic which can support different values of K ranging from 1 to infinity. If K is infinite, then there is no limit on the number of versions. But a separate garbage-collection mechanism is required to collect unwanted versions. On the other hand, when K is 1, it becomes same as a single-version STM system. We prove the correctness and starvation-freedom property of the proposed KSFTM algorithm. To the best of our knowledge, this is the first multi-version STM system that is correct and satisfies starvation-freedom as well. We have also implemented KSFTM and compared its performance with a single version starvation free STM system (SV-SFTM) which works on the priority principle. Our experiments show that KSFTM achieves a speed-up of 2 fold for workloads with 50% update & 50% read operations over SV-SFTM.

1 Introduction

Software Transactional Memory systems (*STMs*) [12, 24] have garnered significant interest as an elegant alternative for addressing synchronization and concurrency issues in multi-core systems. STMs are a convenient programming interface for a programmer to access shared memory without worrying about consistency issues. STMs typically use an optimistic approach in which multiple *transactions* (a piece of code running in the memory) can execute concurrently. During execution, each transaction reads from the shared memory, but all write updates are

*A preliminary version of this work was accepted in AADDA 2017 as **work in progress** and a full version is under concurrent submission at PODC 2018.

[†]A part of this work was submitted towards the fulfillment of M.Tech thesis requirement by the author

[‡]Author sequence follows a lexical order of last names.

performed on local memory. On completion, the STM system *validates* the reads and writes of the transaction. If any inconsistency is found, the transaction is *aborted*, and its local writes are discarded. Otherwise, it *committed*, and its local updates are transferred to the shared memory.

A transaction that has begun but has not yet terminated is referred to as *live*. A typical STM is a library which exports the following methods: *tbegin* which begins a transaction, *stm-read* which reads a *transaction-object* (data item) or *tobj*, *stm-write* which writes to a *tobj*, *tryC* which tries to commit the transaction.

Algorithm 1 Insert(LL, e): Invoked by a thread to insert a value v into a linked-list LL . This method is implemented using transactions.

```

1:  $retry = 0$ ;
2: while ( $true$ ) do
3:    $id = tbegin(retry)$ ;
4:   ...
5:   ...
6:    $v = read(id, x)$ ;
7:   ...
8:   ...
9:    $write(id, x, v')$ ;
10:  ...
11:  ...
12:   $ret = tryC(id)$ ;
13:  if ( $ret == success$ ) then
14:    break;
15:  else
16:     $retry++$ ;
17:  end if
18: end while

```

By committing/aborting the transactions, the STM system ensures atomicity & consistency of transactions. Thus, an important requirement of STMs is to precisely identify the criterion as to when a transaction should be aborted/committed, referred to as *correctness-criterion*. Several *correctness-criteria* have been proposed for STMs such as opacity [9], virtual world consistency [15], local opacity [17, 18], etc. All these correctness-criteria require that all the transactions including aborted to appear to execute sequentially in an order that agrees with the order of non-overlapping transactions. Unlike the correctness criterion for traditional databases, such as serializability, strict-serializability [21], the correctness-criteria for STMs ensure that even aborted transactions read correct values. This ensures that programmers do not see any undesirable side-effects due to the reads of aborted transactions such as infinite-loops, crashes, etc. in the application due to concurrent executions. This additional requirement on aborted transactions is a fundamental requirement of STMs which differentiates STMs from databases as observed by Guerraoui & Kapalka [9, 10].

Another requirement of STM system is to ensure that transactions make *progress*. A well known blocking progress condition associated with concurrent programming in literature is *starvation-freedom* [14, chap 2], [13]. In the context of STMs, starvation-freedom ensures that every aborted transaction that is retried infinitely often eventually commits. It can be defined as: an STM system is said to be starvation-free if a thread invoking a transaction T_i gets the opportunity to retry T_i on every abort (due to the presence of a fair underlying scheduler), then T_i will eventually commit.

Wait-freedom is another interesting progress condition for STMs in which every transaction commits regardless of the nature of concurrent transactions and the underlying scheduler [11, 13]. But it was shown by Guerraoui and Kapalka [3, 10] that it is not possible to achieve wait-freedom in dynamic STMs in which data sets of transactions are not known in advance. So in this paper, we explore the weaker progress condition of starvation-freedom for Transactional Memories.

Algorithm 1 illustrates starvation-freedom. It shows the overview of *insert* method which inserts an element e into a linked-list LL . Insert method is implemented using transactions to ensure correctness in the presence of concurrent updates. The method has an infinite while loop from Line 2 to Line 18. In this while loop, a new transaction is created to read from and write onto the shared memory to create & insert the new node. If the transaction succeeds then the control breaks out of the loop. Otherwise, the method executes until the transaction succeeds. Thus, it can be seen that the insert method can execute forever if no transactions created for insert ever successfully commits. To ensure that insert method eventually completes, the STM system must guarantee

starvation-free execution of transactions (since we have assumed the presence of a fair underlying scheduler). To help STMs achieve starvation-freedom, the invoking thread might pass a parameter such as the number of times this transaction is retried when it invokes the transaction in Line 3. This informs the STM system about the recurring transaction which then schedules the transaction accordingly.

Starvation-freedom in STMs has been explored by a few researchers in literature such as Gramoli et al. [7], Waliullah and Stenstrom [26], Spear et al. [25]. Most of these systems work by assigning priorities to transactions. In case of a conflict between two transactions, the transaction with lower priority is aborted. They ensure that every aborted transaction, on the sufficient number of retries, will eventually have the highest priority and hence commit. Although such priority based systems guarantee starvation-freedom, they can still abort many transactions spuriously. Consider the case where a transaction T_i has the highest priority. Hence, it cannot be aborted as per the priority principle. But if it is slow (for some reason), then it can cause several other conflicting transactions to abort and hence, bring down the efficiency & progress of the entire system.

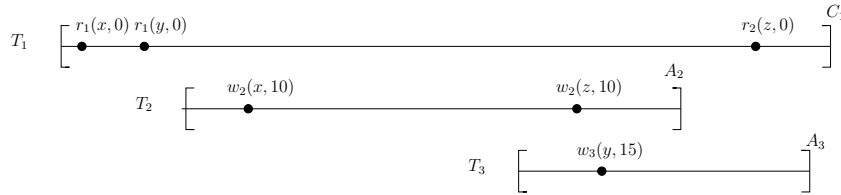

Figure 1: Drawback of Single-Version Starvation Free Algorithms

Figure 1 illustrates this problem. Consider the execution: $r_1(x, 0)r_1(y, 0)w_2(x, 10)w_2(z, 10)w_3(y, 15)$. It has three transactions T_1 , T_2 and T_3 . Suppose T_1 has the highest priority. After reading y , suppose T_1 becomes slow. Next T_2 and T_3 want to write to x , z and y respectively and commit. But T_2 , T_3 , write operations conflict with T_1 's reads. Since T_1 has higher priority and has not committed yet, T_2 and T_3 have to be aborted. If these transactions are retried, and they again conflict with T_1 (if it is still live), then they will again be aborted. Thus, any transaction with the priority lower than T_1 and conflicts with it has to abort. It is as if, T_1 has locked the tobj's x , y and thus does not allow any other transaction accessing these tobj's to proceed.

However, if we use multiple versions for each tobj, then both T_2 and T_3 can commit while not causing T_1 to abort as well. The equivalent serial history is $T_1T_2T_3$. This shows the advantage of using multiple versions. Many STMs have been proposed using the idea of multiple versions [16, 20, 6, 22]. Multi-version STMs by using multiple versions can ensure that more operations to succeed [16, 20]. Hence, multi-version STMs (MVSTMs) can achieve greater concurrency.

On the downside, most of the MVSTMs proposed in the literature do not place a limit on the number of versions created. They have a separate thread that performs *garbage-collection* on old and unwanted versions periodically. But if the old versions are not cleaned frequently, then they add up and affect the performance of the STM system.

In this paper, we explore the problem of achieving starvation-freedom in MVSTM system. We have proposed a K version starvation-free MVSTM system, *KSFTM*. To explain this algorithm, we start with the MVTO algorithm [2, 16] and then walk through a series of changes to reach the final starvation-free algorithm. *KSFTM* maintains K versions where K can range from one to ∞ . When K is one then this it boils down to a single-version STM system. If K is ∞ , then it is similar to existing MVSTMs which do not maintain an upper bound on the number of versions. In this case, a separate garbage-collection thread will be required. When K is finite, then no separate garbage-collection thread will be required to remove the older versions. For correctness, we show *KSFTM* satisfies strict-serializability [21] and local-opacity [17, 18]. To the best of our knowledge, this is the first work to explore starvation-freedom with MVSTMs. We have also implemented *KSFTM* and compared its performance with a single version starvation free STM system (SV-SFTM) which works on the priority principle. Our experiments show that *KSFTM* achieves a two-fold speed-up for workloads with 50% updates operations over SV-SFTM.

2 System Model and Preliminaries

Following [10, 18], we assume a system of n processes/thread, p_1, \dots, p_n that access a collection of *transactional objects* (or *tobj's*) via atomic *transactions*. Each transaction has a unique identifier. Within a transaction, a process can perform *transactional operations or methods*: the *write*(x, v) operation that tries to update a t-object x

with value v , the $read(x)$ operation tries to read x , $tryC()$ that tries to commit the transaction and returns ok if it succeeds, and $tryA()$ that aborts the transaction and returns \mathcal{A} . For the sake of presentation simplicity, we assume that the values taken by arguments by $write$ operations are unique.

Operations $write$, $read$ and $tryC()$ may return \mathcal{A} , in which case we say that the operations *forcefully abort*. Otherwise, we say that the operations have *successfully* executed. Each operation is equipped with a unique transaction identifier. A transaction T_i starts with the first operation and completes when any of its operations return \mathcal{A} or \mathcal{C} . We denote any operation that returns \mathcal{A} or \mathcal{C} as *terminal operations*. Hence, operations $tryC$ and $tryA$ are terminal operations. A transaction does not invoke any further operations after terminal operations.

For a transaction T_k , we denote all the t-objects accessed by its read operations as $rset_{T_k}$ or $rset_k$ and t-objects accessed by its write operations as $wset_{T_k}$ or $wset_k$. We denote all the operations of a transaction T_k as $T_k.evts$ or $evts_k$.

Histories: A *history* is a sequence of *events*, i.e., a sequence of invocations and responses of transactional operations. The collection of events is denoted as $H.evts$. For simplicity, we only consider *sequential* histories here: the invocation of each transactional operation is immediately followed by a matching response. Therefore, we treat each transactional operation as one atomic event, and let $<_H$ denote the total order on the transactional operations incurred by H . With this assumption, the only relevant events of a transaction T_k is of the types: $r_k(x, v)$, $r_k(x, \mathcal{A})$, $w_k(x, v)$, $tryC_k(\mathcal{C})$ (or c_k for short), $tryC_k(\mathcal{A})$, $tryA_k(\mathcal{A})$ (or a_k for short). We identify a history H as tuple $\langle H.evts, <_H \rangle$.

Let $H|T$ denote the history consisting of events of T in H , and $H|p_i$ denote the history consisting of events of p_i in H . We only consider *well-formed* histories here, i.e., (1) each $H|T$ consists of a read-only prefix (consisting of read operations only), followed by a write-only part (consisting of write operations only), possibly *completed* with a $tryC$ or $tryA$ operation^a, and (2) no transaction of a process begins before the previous transaction invocation has completed (either commits or aborts). We also assume that every history has an initial committed transaction T_0 that initializes all the t-objects with value 0.

The set of transactions that appear in H is denoted by $H.txns$. The set of committed (resp., aborted) transactions in H is denoted by $H.committed$ (resp., $H.aborted$). The set of *incomplete* or *live* transactions in H is denoted by $H.incomp = H.live = (H.txns - H.committed - H.aborted)$.

For a history H , we construct the *completion* of H , denoted \bar{H} , by inserting $tryA_k(\mathcal{A})$ immediately after the last event of every transaction $T_k \in H.live$. But for $tryC_i$ if it released the lock on first t-object successfully then T_i will immediately return commit.

Transaction orders: For two transactions $T_k, T_m \in H.txns$, we say that T_k *precedes* T_m in the *real-time order* of H , denote $T_k \prec_H^{RT} T_m$, if T_k is complete in H and the last event of T_k precedes the first event of T_m in H . If neither $T_k \prec_H^{RT} T_m$ nor $T_m \prec_H^{RT} T_k$, then T_k and T_m *overlap* in H . We say that a history is *t-sequential* if all the transactions are ordered by this real-time order. Note that from our earlier assumption all the transactions of a single process are ordered by real-time.

Sub-histories: A *sub-history*, SH of a history H denoted as the tuple $\langle SH.evts, <_{SH} \rangle$ and is defined as: (1) $<_{SH} \subseteq <_H$; (2) $SH.evts \subseteq H.evts$; (3) If an event of a transaction $T_k \in H.txns$ is in SH then all the events of T_k in H should also be in SH .

For a history H , let R be a subset of $H.txns$. Then $H.subhist(R)$ denotes the sub-history of H that is formed from the operations in R .

Valid and legal histories: A successful read $r_k(x, v)$ (i.e., $v \neq \mathcal{A}$) in a history H (i.e., $v \neq \mathcal{A}$), is said to be *valid* if some there is a transaction T_j that wrote v to x and committed before $r_k(x, v)$. Formally, $\langle r_k(x, v) \rangle$ is valid $\Leftrightarrow \exists T_j : (c_j <_H r_k(x, v)) \wedge (w_j(x, v) \in T_j.evts) \wedge (v \neq \mathcal{A})$. The history H is valid if all its successful read operations are valid.

We define $r_k(x, v)$'s *lastWrite* as the latest commit event c_i preceding $r_k(x, v)$ in H such that $x \in Wset(T_i)$ (T_i can also be T_0). A successful read operation $r_k(x, v)$, is said to be *legal* if the transaction containing r_k 's lastWrite also writes v onto x : $\langle r_k(x, v) \rangle$ is legal $\Leftrightarrow (v \neq \mathcal{A}) \wedge (H.lastWrite(r_k(x, v)) = c_i) \wedge (w_i(x, v) \in T_i.evts)$. The history H is legal if all its successful read operations are legal. From the definitions we get that if H is legal then it is also valid.

Opacity and Strict Serializability: We say that two histories H and H' are *equivalent* if they have the same set of events. Now a history H is said to be *opaque* [9, 10] if it is valid and there exists a t-sequential legal history S such that (1) S is equivalent to \bar{H} and (2) S respects \prec_H^{RT} , i.e., $\prec_H^{RT} \subset \prec_S^{RT}$. By requiring S being equivalent to \bar{H} , opacity treats all the incomplete transactions as aborted. We call S an (opaque) *serialization* of H .

^aIt was shown in [19] that this restriction brings no loss of generality.

Along same lines, a valid history H is said to be *strictly serializable* if $H.subhist(H.committed)$ is opaque. Unlike opacity, strict serializability does not include aborted or incomplete transactions in the global serialization order. An opaque history H is also strictly serializable: a serialization of $H.subhist(H.committed)$ is simply the subsequence of a serialization of H that only contains transactions in $H.committed$.

Serializability is commonly used criterion in Databases. But it is not suitable for STMs as it does not consider the correctness of aborted transactions as shown by Guerraoui & Kapalka [9]. Opacity, on the other hand, considers the correctness of aborted transactions as well. Similarly, loc-opacity (described below) is another correctness-criterion for STMs but is not as restrictive as opacity.

Local opacity: For a history H , we define set of sub-histories, denoted as $H.subhistSet$ as follows: (1) For each aborted transaction T_i , we consider a *subhist* consisting of operations from all previously committed transactions and including all successful operations of T_i (i.e., operations which did not return \mathcal{A}) while immediately putting commit after last successful operation of T_i ; (2) for last committed transaction T_l consider all the previously committed transactions including T_l .

We illustrate loc-opacity with an example. Consider a history $H1$ with multiple reads and writes on different tobjcs:

$w_1(x, 1)C_1r_2(x, 1)w_3(x, 3)w_3(y_3)C_3r_4(y, 3)w_4(k, 4)C_4r_5(k, 4)r_5(z, 0)w_2(z, 2)C_2A_5$ as shown in Figure 2. It can be verified that $H1$ is not opaque but loc-opaque. $H4$ has one aborted transaction T_5 . The sub-history corresponding to T_5 will have operations belonging to transactions: T_1, T_3, T_4 and not T_2 since it did not commit before T_5 . Thus the corresponding serialization is: $T_1T_3T_4T_5$. Next coming to the last committed transaction T_2 , the corresponding sub-history will have operations from all the preceding committed transaction. The corresponding serialization is: $T_1T_3T_4T_2$.

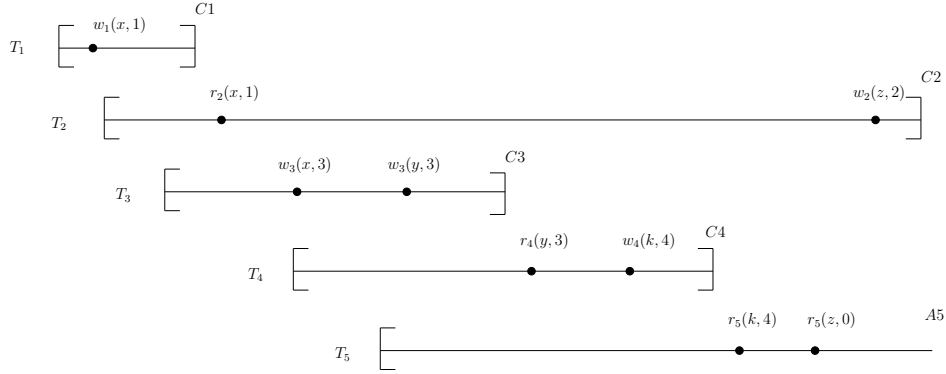

Figure 2: A locally opaque, but not opaque history $H1$

A history H is said to be *locally opaque* or *loc-opaque* [17, 18] if all the sub-histories in $H.subhistSet$ are opaque. It must be seen that in the construction of sub-history of an aborted transaction T_i , the *subhist* will contain operations from only one aborted transaction which is T_i itself and no other live/aborted transactions. Similarly, the sub-history of committed transaction T_l has no operations of aborted & live transactions. Thus in loc-opacity, no aborted or live transaction can cause another transaction to abort. It was shown that loc-opacity [17, 18] allows greater concurrency than opacity. Any history that is opaque is also loc-opaque but not necessarily the vice-versa. On the other hand, a history that is loc-opaque is also strict-serializable, but the vice-versa need not be true. We illustrate loc-opacity with an example in the Appendix.

3 The Working of KSFTM Algorithm

In this section, we start with the explanation of starvation-freedom. Then we describe how the application invokes transactions to achieve starvation-freedom, the data-structures used. To explain the intuition for the main KSFTM algorithm, we will start with MVTO [2, 16] algorithm. We then make a sequence of modifications to it to arrive at the final KSFTM algorithm.

Starvation Freedom: A STM system is said to be starvation-free if a thread invoking a transaction T_i gets the opportunity to retry T_i on every abort due to the presence of a fair scheduler then T_i will eventually commit (as described in Section 1). As explained by Herlihy & Shavit [14], a fair scheduler implies that no thread is forever delayed or crashed. Hence with this assumption of a fair scheduler, we get that if in the course of execution a

thread acquires locks then it will eventually release the locks. Since it is not forever delayed, it cannot block out other threads from progressing.

Transaction Invocation: Transactions are invoked by a thread. Suppose a thread Th_x invokes a transaction T_i . If this transaction T_i gets aborted, Th will reissue it, as a new incarnation of T_i , say T_j . T_i and T_j are said to *incarnations* of each other. The thread Th_x will continue to invoke new incarnations of T_i until an incarnation commits.

When a transaction T_i begins, it is assigned a unique timestamp called *current timestamp* or *CTS* by the STM system. If it is aborted and retried again as T_j , then its CTS will change. However, in this case, the thread Th_x will also pass the CTS value of the first incarnation (T_i) to T_j . By this, Th_x informs the STM system this T_j is not the initial invocation and is an incarnation of T_i .

We denote the CTS of T_i (first incarnation) as *Initial Timestamp* or *ITS* for all the incarnations of T_i . Thus, the invoking thread Th_x passes cts_i to all the incarnations of T_i (including T_j). Thus for T_j , $cts_j = its_i$. The transaction T_j is associated with the timestamps: $\langle its_j, cts_j \rangle$. For T_i , which is the initial incarnation, its ITS and CTS are the same, i.e., $its_i = cts_i$.

3.1 Motivation for Starvation Freedom in Multi-Version Systems

In this section, first we describe the starvation freedom solution used for single version i.e. SV-SFTM algorithm and then the drawback of it.

3.1.1 Illustration of SV-SFTM

Forward-oriented optimistic concurrency control protocol (FOCC), is a commonly used optimistic algorithm in databases [27, Chap 4]. In fact, several STM Systems are also based on this idea. In a typical STM system (also in database optimistic concurrency control algorithms), a transaction execution is divided can be two phases - a *read/local-write phase* and *try-Commit phase* (also referred to as validation phase in databases). The various algorithms differ in how the try-Commit phase executes. Let the write-set or wset and read-set or rset of a t_i denotes the set of tobj's written & read by t_i . In FOCC a transaction t_i in its try-Commit phase is validated against all live transactions that are in their read/local-write phase as follows: $\langle wset(t_i) \cap (\forall t_j : rset^n(t_j)) = \Phi \rangle$. This implies that the wset of t_i can not have any conflict with the current rset of any transaction t_j in its read/local-write phase. Here $rset^n(t_j)$ implies the rset of t_j till the point of validation of t_i . If there is a conflict, then either t_i or t_j (all transactions conflicting with t_i) is aborted. A commonly used approach in databases is to abort t_i , the validating transaction.

In SV-SFTM we use τ_{ss} which are monotonically in increasing order. We implement the τ_{ss} using atomic counters. Each transaction t_i has two time-stamps: (i) *current time-stamp* or *CTS*: this is a unique τ_s allotted to t_i when it begins; (ii) *initial time-stamp* or *ITS*: this is same as CTS when a transaction t_i starts for the first time. When t_i aborts and re-starts later, it gets a new CTS. But it retains its original CTS as ITS. The value of ITS is retained across aborts. For achieving starvation freedom, SV-SFTM uses ITS with a modification to FOCC as follows: a transaction t_i in try-Commit phase is validated against all other conflicting transactions, say t_j which are in their read/local-write phase. The ITS of t_i is compared with the ITS of any such transaction t_j . If ITS of t_i is smaller than ITS of all such t_j , then all such t_j are aborted while t_i is committed. Otherwise, t_i is aborted. We show that SV-SFTM satisfies opacity and starvation-free.

Theorem 1 *Any history generated by SV-SFTM is opaque.*

Theorem 2 *SV-SFTM ensure starvation-freedom.*

We prove the correctness by showing that the conflict graph [27, Chap 3], [17] of any history generated by SV-SFTM is acyclic. We show starvation-freedom by showing that for each transaction t_i there eventually exists a global state in which it has the smallest ITS.

Figure 3 shows the a sample execution of SV-SFTM. It compares the execution of FOCC with SV-SFTM. The execution on the left corresponds to FOCC, while the execution one the right is of SV-SFTM for the same input. It can be seen that each transaction has two τ_{ss} in SV-SFTM. They correspond to CTS, ITS respectively. Thus, transaction $T_{1,1}$ implies that CTS and ITS are 1. In this execution, transaction T_3 executes the read operation $r_3(z)$ and is aborted due to conflict with T_2 . The same happens with $T_{3,3}$. Transaction T_5 is re-execution of T_3 . With FOCC T_5 again aborts due to conflict with T_4 . In case of SV-SFTM, $T_{5,3}$ which is re-execution of $T_{3,3}$ has the same ITS 3. Hence, when $T_{4,4}$ validates in SV-SFTM, it aborts as $T_{5,3}$ has lower ITS. Later $T_{5,3}$ commits.

It can be seen that ITSs prioritizes the transactions under conflict and the transaction with lower ITS is given higher priority.

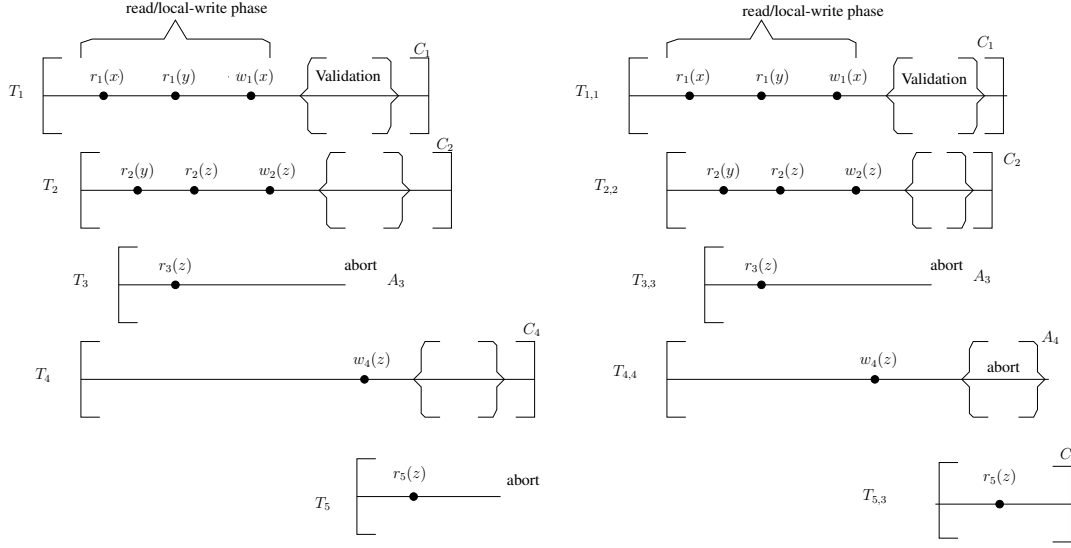

Figure 3: Sample execution of SV-SFTM

3.1.2 drawback of SV-SFTM

Figure 4 is representing history H: $r_1(x, 0)r_1(y, 0)w_2(x, 10)w_3(y, 15)a_2a_3c_1$. It has three transactions T_1 , T_2 and T_3 . T_1 is having lowest time stamp and after reading it became slow. T_2 and T_3 wants to write to x and y respectively but when it came into validation phase, due to $r_1(x)$, $r_1(y)$ and not committed yet, T_2 and T_3 gets aborted. However, when we are using multiple version T_2 and T_3 both can commit and T_1 can also read from T_0 . The equivalent serial history is $T_1T_2T_3$.

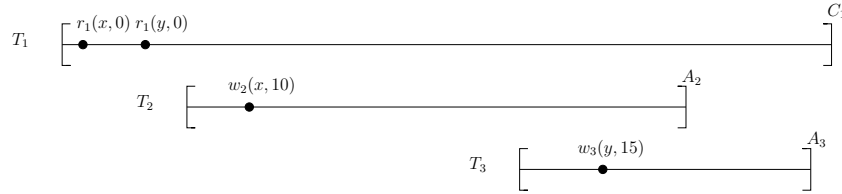

Figure 4: Pictorial representation of execution under SFTM

3.1.3 Data Structures and Pseudocode of SV-SFTM

We start with data-structures that are local to each transaction. For each transaction T_i :

- $rset_i$ (read-set): It is a list of data tuples (d_tuples) of the form $\langle x, val \rangle$, where x is the t-object and val is the value read by the transaction T_i . We refer to a tuple in T_i 's read-set by $rset_i[x]$.
- $wset_i$ (write-set): It is a list of (d_tuples) of the form $\langle x, val \rangle$, where x is the tobj to which transaction T_i writes the value val . Similarly, we refer to a tuple in T_i 's write-set by $wset_i[x]$.

In addition to these local structures, the following shared global structures are maintained that are shared across transactions (and hence, threads). We name all the shared variable starting with 'G'.

- G_tCntr (counter): This a numerical valued counter that is incremented when a transaction begins.

For each transaction T_i we maintain the following shared time-stamps:

- G_{lock_i} : A lock for accessing all the shared variables of T_i .
- G_{its_i} (initial timestamp): It is a time-stamp assigned to T_i when it was invoked for the first time.
- G_{cts_i} (current timestamp): It is a time-stamp when T_i is invoked again at a later time. When T_i is created for the first time, then its G_{cts} is same as its its .
- G_{valid_i} : This is a boolean variable which is initially true (T). If it becomes false (F) then T_i has to be aborted.
- G_{state_i} : This is a variable which states the current value of T_i . It has three states: live, commit or abort.

For each data item x in history H , we maintain:

- $x.val$ (value): It is the successful previous closest value written by any transaction.
- $x.rl$ (readList): It is the read list consists of all the transactions that have read x .

Algorithm 2 STM $init()$: Invoked at the start of the STM system. Initializes all the data items used by the STM System

```

1:  $G_{tCntr} = 1$ ;
2: for all data item  $x$  used by the STM System do
3:   add  $\langle 0, nil \rangle$  to  $x.val$ ; /*  $T_0$  is initializing  $x$  */
4: end for;
```

Algorithm 3 STM $tbegin(its)$: Invoked by a thread to start a new transaction T_i . Thread can pass a parameter its which is the initial timestamp when this transaction was invoked for the first time. If this is the first invocation then its is nil . It returns the tuple $\langle id, G_{cts} \rangle$

```

1:  $i = \text{unique-id}$ ; /* An unique id to identify this transaction. It could be same as  $G_{cts}$ . */
2: if ( $its == nil$ ) then
3:    $G_{its_i} = G_{cts_i} = G_{tCntr}.get\&Inc()$ ;
4:   /*  $G_{tCntr}.get\&Inc()$  returns the current value of  $G_{tCntr}$  and atomically increments it by 1. */
5: else
6:    $G_{its_i} = its$ ;
7:    $G_{cts_i} = G_{tCntr}.get\&Inc()$ ;
8: end if
9:  $rset_i = wset_i = null$ ;
10:  $G_{state_i} = \text{live}$ ;
11:  $G_{valid_i} = T$ ;
12: return  $\langle i, G_{cts_i} \rangle$ 
```

Algorithm 5 STM $write_i(x, val)$: A Transaction T_i writes into local memory

```

1: Append the  $d\_tuple\langle x, val \rangle$  to  $wset_i$ ; /* If same dataitem then overwrite the tuple */
2: return  $ok$ ;
```

Algorithm 6 STM $findLLTS(TSet)$: Find the lowest its value among all the live trasactions in $TSet$.

```

1:  $min\_its = \infty$ 
2: for all ( $T_j \in TSet$ ) do
3:   if ( $(G_{its_j} < min\_its) \ \&\& \ (G_{state_j} == \text{live})$ ) then
4:      $min\_its = G_{its_j}$ ;
5:   end if
6: end for
7: return  $min\_its$ ;
```

Algorithm 4 STM $read(i, x)$: Invoked by a transaction T_i to read x . It returns either the value of x or \mathcal{A}

```
1: if ( $x \in wset_i$ ) then /* Check if  $x$  is in  $wset_i$  */
2:   return  $wset_i[x].val$ ;
3: else if ( $x \in rset_i$ ) then /* Check if  $x$  is in  $rset_i$  */
4:   return  $rset_i[x].val$ ;
5: else /*  $x$  is not in  $rset_i$  and  $wset_i$  */
6:   lock  $x$ ;
7:   lock  $G\_lock_i$ ;
8:   if ( $G\_valid_i == F$ ) then
9:     return  $abort(i)$ ;
10:  end if
11:   $val = x.val$ ;
12:  add  $T_i$  to  $x.rl$ ;
13:  unlock  $G\_lock_i$ ;
14:  unlock  $x$ ;
15:  return  $val$ ;
16: end if
```

Algorithm 7 STM $tryC()$: Returns \mathcal{C} on commit else return Abort \mathcal{A}

```
1: lock  $G\_lock_i$ 
2: if ( $G\_valid_i == F$ ) then return  $abort(i)$ ;
3: end if
4:  $TSet = null$  /*  $TSet$  storing transaction Ids */
5: for all ( $x \in wset_i$ ) do
6:   lock  $x$  in pre-defined order;
7:   for all ( $T_j \in x.rl$ ) do
8:      $TSet = TSet \cup \{T_j\}$ 
9:   end for
10: end for /*  $x \in wset_i$  */
11:  $TSet = TSet \cup \{T_i\}$  /* Add current transaction  $T_i$  into  $TSet$  */
12: for all ( $T_k \in TSet$ ) do
13:   lock  $G\_lock_k$  in pre-defined order; /* Note: Since  $T_i$  is also in  $TSet$ ,  $G\_lock_i$  is also locked */
14: end for
15: if ( $G\_valid_i == F$ ) then return  $abort(i)$ ;
16: else
17:   if ( $G\_its_i == findLLTS(TSet)$ ) then /* Check if  $T_i$  has lowest  $its$  among all live transactions in  $TSet$  */
18:     for all ( $T_j \in TSet$ ) do /* ( $T_i \neq T_j$ ) */
19:        $G\_valid_j = F$ 
20:       unlock  $G\_lock_j$ ;
21:     end for
22:   else
23:     return  $abort(i)$ ;
24:   end if
25: end if
26: for all ( $x \in wset_i$ ) do
27:   replace the old value in  $x.val$  with  $newValue$ ;
28:    $x.rl = null$ ;
29: end for
30:  $G\_state_i = commit$ ;
31: unlock all variables locked by  $T_i$ ;
32: return  $\mathcal{C}$ ;
```

Algorithm 8 $abort(i)$: Invoked by various STM methods to abort transaction T_i . It returns \mathcal{A}

- 1: $G_valid_i = F$;
 - 2: $G_state_i = abort$;
 - 3: unlock all variables locked by T_i ;
 - 4: return \mathcal{A} ;
-

Common Data-Structures & STM Methods: Here we describe the common data-structures used by all the algorithms proposed in this section. For each tobj, the algorithm(s) maintains multiple version as a linked-list, $vlist$. Similar to versions in MVTO [16], each version of a tobj is a tuple denoted as $vTuple$ and consists of three fields: (1) timestamp, ts of the transaction that created this version which normally is the CTS; (2) the value of the version; (3) a list, called read-list, consisting of transactions ids (could be CTS as well) that read from this version. The read-list of a version is initially empty. Figure 5 illustrates this structure. For a tobj x , we use the notation $x[t]$ to access the version with timestamp t . Depending on the algorithm considered, the fields change of this structure.

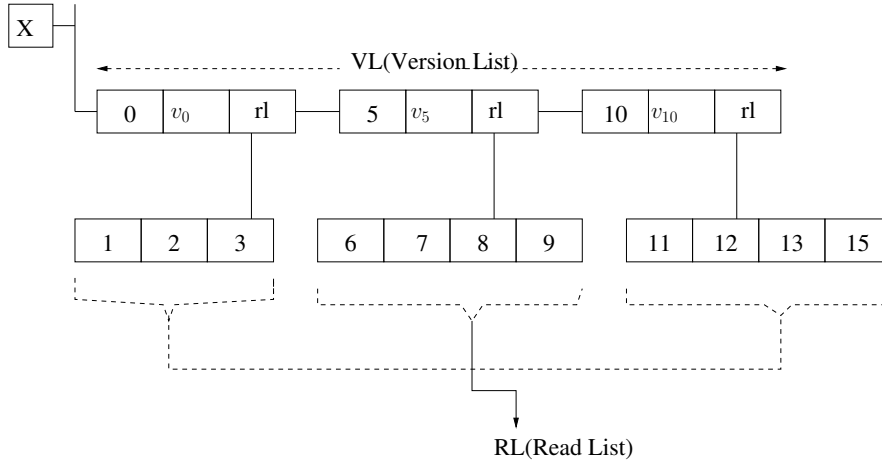

Figure 5: Data Structures for Maintaining Versions

The algorithms have access to a global atomic counter, G_tCntr used for generating timestamps in the various transactional methods. We assume that the STM system exports the following methods for a transaction T_i : (1) $tbegin(t)$ where t is provided by the invoking thread. From our earlier assumption, it is the CTS of the first incarnation. This method returns a unique timestamp to the invoking thread which is the CTS/id of the transaction. (2) $stm-read_i(x)$ tries to read tobj x . It returns either value v or \mathcal{A} . (3) $stm-write_i(x, v)$ operation that tries to update a tobj x with value v . It returns ok . (4) $tryC_i()$ that tries to commit the transaction and returns ok if it succeeds. Otherwise, it returns \mathcal{A} . (5) $tryA()$ that aborts the transaction and returns \mathcal{A} .

Simplifying Assumptions: We next describe the main idea behind the starvation-free STM algorithm KSFTM through a sequence of algorithms. For ease of exposition, we make two simplifying assumptions (1) We assume that in the absence of other concurrent conflicting transactions, every transaction will commit. In other words, if a transaction is executed in a system by itself, it will not self-abort. (2) We initially consider strict-serializability as correctness-criterion to illustrate the correctness of the algorithms. But strict-serializability does not consider the correctness of aborted transactions and as a result not a suitable correctness-criterion for STMs. Finally, we show that the proposed STM algorithm KSFTM satisfies loc-opacity, a correctness-criterion for STMs.

We denote the set of histories generated by an STM algorithm, say A , as $gen(A)$.

3.2 Priority-based MVTO Algorithm

In this subsection, we describe a modification to the MVTO algorithm to ensure that it provides preference to transactions that have low ITS, i.e., transactions that have been in the system for a longer time. It also maintains a finite number of version K . We call this algorithm as *Priority-based MVTO* or *PMVTO*. We describe the main idea behind begin, read, write and tryC operations executed by a transaction T_i . We have not described the details of locking of data-items by transactions. Here, we use the notation that i represents the CTS of T_i .

tbegin(t): A unique timestamp ts is allocated to T_i which is its CTS (i from our assumption). The timestamp ts is generated by atomically incrementing the global counter G_tCntr . If the input t is null, then $cts_i = its_i = ts$ as this is the first incarnation of this transaction. Otherwise, the non-null value of t is assigned as its_i .

stm-read(x): Transaction T_i reads from a version of x with timestamp j such that j is the largest timestamp less than i (among the versions x), i.e., there exists no version k such that $j < k < i$ is true. After reading this version of x , T_i is stored in $x[j]$'s read-list. If no such version exists then T_i is aborted.

stm-write(x, v): T_i stores this write to value x locally in its $wset_i$.

tryC : This operation consists of two steps. In Step 1, it checks whether T_i can be committed. In Step 2, it performs the necessary tasks to mark T_i as a committed transaction.

1. Before T_i can commit, it needs to verify that any object it updates is updated consistently. When T_i creates a new version, it will be with timestamp i . Hence, T_i needs to make sure that any transaction that has read a previous version is not affected by the new version created by T_i . Now, there are two possibilities of concern:
 - (a) The previous version has been read by some transaction, say T_k . In this scenario, the value read by T_k would be incorrect (w.r.t strict-serializability) if T_i is allowed to create a new version. In this case, we say that the transactions T_i and T_k are in *conflict*.
So, we do the following: (i) if T_k has already committed then T_i is aborted; (ii) if T_k is live and its_k is less than its_i . Then again T_i is aborted; (iii) If T_k is still live with its_i less than its_k then T_k is aborted.
 - (b) The previous version does not exist. This happens when the previous version has been overwritten. In this case, T_i is aborted since PMVTO does not know if T_i conflicts with any other transaction T_k that has read the previous version.
2. After Step 1, we have verified that it is ok for T_i to commit. Now, we have to create a version of each $tobj$ x in the wset of T_i . This is achieved as follows:
 - (a) T_i creates a vTuple $\langle i, wset_i.x.v, nil \rangle$. In this tuple, i (CTS of T_i) is the timestamp of the new version; $wset_i.x.v$ is the value of x in T_i 's wset, and the read-list of the vTuple is nil .
 - (b) Suppose the total number of versions of x is K . Then among all the versions of x , T_i replaces the version with the smallest timestamp with vTuple $\langle i, wset_i.x.v, nil \rangle$. Otherwise, the vTuple is added to x 's vlist.
3. Transaction t_i is then committed.

The algorithm described here is only the main idea. The actual implementation will use locks. It can be seen that PMVTO gives preference to the transaction having lower ITS in Step 1a. Transactions having lower ITS have been in the system for a longer time. Hence, PMVTO gives preference to them. We have the following property on the correctness of PMVTO.

Property 3 Any history generated by PMVTO is strict-serializable.

Consider a history H generated by PMVTO. Let the committed sub-history of H be $CSH = H.subhist(H.committed)$. It can be shown that CSH is opaque with the equivalent serialized history SH' is one in which all the transactions of CSH are ordered by their CTSs. Hence, H is strict-serializable.

The drawback of PMVTO: As discussed above, PMVTO gives priority to transactions having lower ITS. But a transaction T_i having the lowest ITS could still abort due to one of the following reasons: (1) Upon executing *stm-read(x)* method if it does not find any other version of x to read from. This can happen if all the versions of x present have a timestamp greater than CTS_i . (2) While executing Step 1a(i), of the *tryC* method, if T_i wishes to create a version of x with timestamp i . But some other transaction, say T_k has read from a version with timestamp j and $j < i < k$. In this case, T_i has to abort if T_k has already committed.

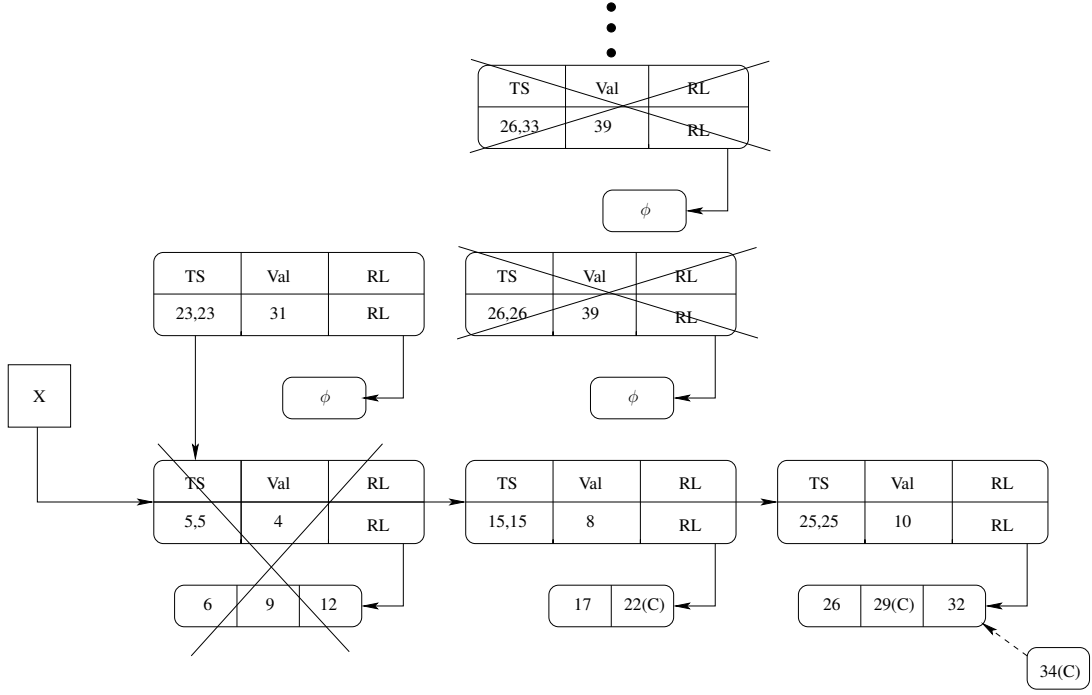

Figure 6: Pictorial representation of execution under PMVTO

Figure 6 represents the execution of PMVTO algorithm, in which transaction T_{26} , with ITS 26 is the lowest among all the live transactions, starves due to Step 1a.(i) of the tryC. First time T_{26} gets aborted due to higher timestamp transaction T_{29} in the read-list of $x[25]$ has committed. We have denoted it by a '(C)' next to the version. After that T_{26} retries with same ITS 26 but new CTS 33. Now when T_{33} comes for commit, suppose another transaction T_{34} in the read-list of $x[25]$ has already committed. So this will cause T_{33} (T_{26}) to abort again. Such scenario can repeat again & again and thus possibly cause that no incarnation of T_{26} will ever commit leading to starvation.

3.3 Adding Starvation-Freedom to PMVTO: SFMTO

Our goal is to revise PMVTO algorithm to ensure that starvation-freedom is preserved. Specifically, we want the transaction with the lowest ITS to eventually commit. Once this happens, the next transaction with the lowest ITS will commit. Thus, from induction, we can see that every transaction will eventually commit.

To identify the necessary revision, we first focus on the effect of this algorithm on two transactions, say T_{50} and T_{60} with their CTS values being 50 and 60 respectively. Furthermore, for the sake of discussion, assume that these transactions only read and write variable x . Also, assume that the latest version for x is at time 40. Thus, each transaction first reads x and then writes x (as part of the tryC operation). We use r_{50} and r_{60} to denote their read operations while w_{50} w_{60} to denote their tryC operation. Here, a read operation will not fail as there is a previous version present.

Given that the read operation must occur before write/commit, there are six possible permutations of these statements. We identify these permutations and the action that should be taken for that permutation in Table 1.

S. No	Sequence	Action
1.	$r_{50}, w_{50}, r_{60}, w_{60}$	T_{60} reads the version written by T_{50} . No conflict.
2.	$r_{50}, r_{60}, w_{50}, w_{60}$	Conflict detected at w_{50} . Either abort T_{50} or T_{60} .
3.	$r_{50}, r_{60}, w_{60}, w_{50}$	Conflict detected at w_{50} . Hence, abort T_{50} .
4.	$r_{60}, r_{50}, w_{60}, w_{50}$	Conflict detected at w_{50} . Hence, abort T_{50} .
5.	$r_{60}, r_{50}, w_{50}, w_{60}$	Conflict detected at w_{50} . Either abort T_{50} or T_{60} .
6.	$r_{60}, w_{60}, r_{50}, w_{50}$	Conflict detected at w_{50} . Hence, abort T_{50} .

Table 1: Permutations of operations

From this table, it can be seen that when a conflict is detected, in some cases, algorithm PMVTO *must* abort T_{50} . In case none of the transactions have terminated, PMVTO has the option of aborting either transaction depending on their ITS. Suppose T_{60} has lower ITS. Then, in no case, PMVTO is required to abort T_{60} . In other words, it is possible to ensure that the transaction with lowest ITS and the highest CTS is never aborted. Although in this example, we considered only one tobj, this logic can be extended to cases having more number of operations and tobjs.

Next, consider Step 1b of PMVTO algorithm. Suppose a transaction T_i want to read a tobj but does not find a version with a timestamp smaller than i . In this case, T_i has to abort. But if T_i has the highest CTS, then it will certainly find a version to read from. This reinforces the above observation.

To summarize the discussion, algorithm *PMVTO* has an in-built mechanism to protect transactions with lower ITS & higher CTS value. However, this is different from what we need. Specifically, we want to protect a transaction T_i , with lowest *ITS* value. One way to ensure this: if transaction T_i with lowest ITS keeps getting aborted, eventually it will achieve the highest CTS. Once this happens, PMVTO ensures that T_i cannot be further aborted. In this way, we can ensure liveness of all transactions.

To realize this idea and achieve starvation-freedom, we consider a variation of MVTO, *Starvation Free MVTO* or *SFMTO*. A transaction T_i instead of using the current time as cts_i , uses a potentially higher timestamp, *Working Timestamp - WTS* or wts_i . Specifically, it adds $C * (cts_i - its_i)$ to cts_i , i.e., $wts_i = cts_i + C * (cts_i - its_i)$; where, C is any constant greater than or equal to 1.

In other words, when the transaction T_i is issued for the first time, wts_i is same as $cts_i (= its_i)$. However, as transaction keeps getting aborted, the drift between cts_i and wts_i increases. The value of wts_i increases with each retry.

Furthermore, in SFMTO algorithm, CTS is replaced with WTS for stm-read, stm-write & tryC operations. In SFMTO, a transaction T_i uses wts_i to read a version from in stm-read. Similarly, T_i uses wts_i in tryC to find the appropriate previous version (in Step 1b) and to verify if T_i has to be aborted (in Step 1a). Along the same lines, once T_i decides to commit and create new versions of x , the timestamp of x will be same as its wts_i (in Step 3). Thus the timestamp of all the versions in vlist will be WTS of the transactions that created them. Now, we have the following property about SFMTO algorithm.

Property 4 *SFMTO algorithm ensures starvation-freedom.*

While the proof of this property is somewhat involved, the key idea is that the transaction with lowest ITS value, say T_{low} , will eventually have highest WTS value than all the other transactions in the system. Moreover, after a certain duration, any *new* transaction arriving in the system (i.e., whose *ITS* value sufficiently higher than that of T_{low}) will have a lower *WTS* value than T_{low} . This will ensure that T_{low} will not be aborted. This has been captured in Theorem 51 of Section 6 while proving liveness of KSFTM in the Appendix.

The drawback of SFMTO: Although SFMTO satisfies starvation-freedom, it, unfortunately, does not satisfy strict-serializability. Specifically, it violates the real-time requirement. PMVTO uses CTS for its working while SFMTO uses WTS. It can be seen that CTS is close to the real-time execution of transactions whereas WTS of a transaction T_i is artificially inflated based on its ITS and might be much larger than its CTS.

We illustrate this with an example. Consider the history $H1$ as shown in Figure 7: $r_1(x, 0)r_2(y, 0)w_1(x, 10)c_1w_2(x, 20)c_2r_3(x, 10)r_3(y, 25)c_3$ with CTS as 50, 60 & 80 and WTS as 50, 100 & 80 for T_1, T_2, T_3 respectively. Here T_1, T_2 are ordered before T_3 in real-time with $T_1 \prec_{H1}^{RT} T_3$ and $T_2 \prec_{H1}^{RT} T_3$ although T_2 has a higher WTS than T_3 .

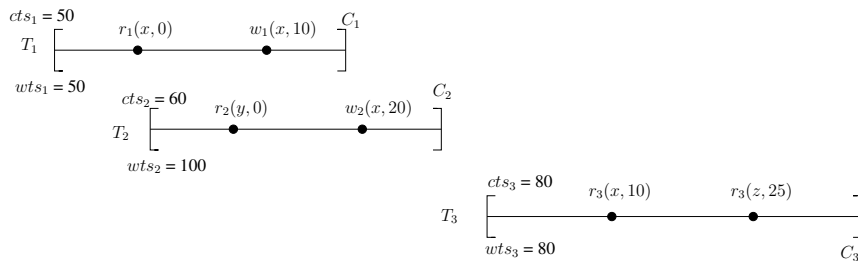

Figure 7: Correctness of SFMTO Algorithm

Here, as per SFMTO algorithm, T_3 reads x from T_1 since T_1 has the largest WTS (50) smaller than T_3 's WTS (80). It can be verified that it is possible for SFMTO to generate such a history. But this history is not

strict-serializable. The only possible serial order equivalent to $H1$ and legal is $T_1T_3T_2$. But this violates real-time order as T_3 is serialized before T_2 but in $H1$, T_2 completes before T_3 has begun. Since $H1$ is not strict-serializable, it is not loc-opaque as well.

3.4 Modifying SFMTO to Achieve Correctness: KSFTM

In this section, we discuss how we can modify SFMTO so that it provides strict-serializability without sacrificing its starvation-freedom property. To achieve this, we first understand why the initial algorithm, PMVTO satisfied strict-serializability- which is because CTS was used for creating ordering among committed transactions. CTS is closely associated with real-time. By contrast, SFMTO uses WTS and it may not correspond to the real-time, as WTS may be significantly higher than CTS (which corresponds to the real-time) as shown by $H1$ in Figure 7.

One straightforward way to modify SFMTO is to delay a committing transaction, say T_i with WTS value WTS_i until the real-time ($G.tCntr$) catches up to WTS_i . This will ensure that value of WTS will also correspond to real-time thereby guaranteeing strict-serializability. However, this is unacceptable, as in practice, it would require transaction T_i locking all the variables it plans to update and wait. This will heavily affect the performance of the modified algorithm.

We can allow the transaction T_i to commit before its wts_i has caught up with the actual time if it does not violate the real-time ordering. Thus, to ensure that the notion of real-time order is respected by transactions in the course of their execution in SFMTO, we add extra time constraints. We use the idea of timestamp ranges. This notion of timestamp ranges was first used by Riegel et al. [23] in the context of multi-version STMs. Several other researchers have used this idea since then such as Guerraoui et al. [8], Crain et al. [5], Aydonat & Abdelrahman [1].

Thus, in addition to ITS, CTS & WTS, each transaction T_i maintains a timestamp range: *Transaction Lower Timestamp Limit* or $lttl_i$, and *Transaction Upper Timestamp Limit* or $tutl_i$. When a transaction T_i begins, $lttl_i$ is assigned cts_i and $tutl_i$ is assigned ∞ . When T_i executes a method m in which it reads a version of a tobj x or creates a new version of x in tryC, $lttl_i$ is incremented while $tutl_i$ gets decremented.

Our requirement is to serialize all the transactions based on their WTS while maintaining their real-time order. On executing m , T_i is ordered w.r.t to other transactions that have created a version of x based on increasing order of WTS. For all transactions T_j which also have created a version of x and whose wts_j is less than wts_i , $lttl_i$ is incremented such that $tutl_j$ is less than $lttl_i$. Note that all such T_j are serialized before T_i . Similarly, for all transactions T_k which have created a version of x and whose wts_k is greater than wts_i , $tutl_i$ is decremented such that it becomes less than $lttl_k$. Again, note that all such T_k is serialized after T_i . After the increments of $lttl_i$ & the decrements of $tutl_i$, if $lttl_i$ turns out to be greater than $tutl_i$ then T_i is aborted. Intuitively, this implies that T_i 's WTS and real-time orders are out of *sync* and cannot be reconciled.

Finally, when a transaction T_i commits: (1) T_i records its $comTime_i$ by getting the current value of $G.tCntr$ and incrementing it by any value greater than equal to $1 + C$. Then $tutl_i$ is set to $comTime_i$ if it is not already less than it. Now suppose T_i occurs in real-time before some other transaction, T_j but does not have any conflict with it. This step ensures that $tutl_i$ remains less than $lttl_j$ (which is initialized with cts_j); (2) Ensure that $lttl_i$ is still less than $tutl_i$. Otherwise, T_i is aborted.

Let us illustrate this technique with the history $H1$ shown in Figure 7. When T_1 starts its $cts_1 = 50$, $lttl_1 = 50$, $tutl_1 = \infty$. Now when T_1 commits, suppose $G.tCntr$ is 70. Hence, $tutl_1$ reduces to 70. Next when T_2 commits, suppose $tutl_2$ reduces to 75 (from the value of $G.tCntr$). As T_1, T_2 have accessed a common tobj x in a conflicting manner, $lttl_2$ is incremented to a value greater than $tutl_1$, say 71. Next, when T_3 begins, $lttl_3$ is assigned cts_3 which is 80 and $tutl_3$ is initialized to ∞ . When T_3 executes $r_3(x)$, $tutl_3$ is reduced to a value less than $lttl_2 (= 71)$, say 70. But $lttl_3$ is already at 80. Hence, the limits of T_3 have crossed and thus causing T_3 to abort. The resulting history consisting of only committed transactions T_1T_2 is strict-serializable.

Based on this idea, we next develop a variation of SFMTO, *K-version Multi-Version Starvation Free STM System* or *KSFTM*. To explain this algorithm, we first describe the structure of the version of a tobj used. It is a slight variation of the tobj used in PMVTO algorithm. It consists of: (1) timestamp, ts which is the WTS of the transaction that created this version (and not CTS unlike PMVTO); (2) the value of the version; (3) a list, called read-list, consisting of transactions ids (could be CTS as well) that read from this version; (4) version real-time timestamp or vrt which is the $tutl$ of the transaction that created this version. Thus a version has information of WTS and $tutl$ of the transaction that created it.

Now, we describe the main idea behind begin, read, write and tryC operations of a transaction T_i which is an extension of PMVTO. Note that as per our notation i represents the CTS of T_i .

tbgin(t): An unique timestamp ts is allocated to T_i which is its CTS (i from our assumption) which is generated

by atomically incrementing the global counter G_tCntr . If the input t is null then $cts_i = its_i = ts$ as this is the first incarnation of this transaction. Otherwise, the non-null value of t is assigned to its_i . Then, WTS is computed as $wts_i = cts_i + C * (cts_i - its_i)$. Finally, $tltl$ & $tutl$ are initialized: $tltl_i = cts_i, tutl_i = \infty$.

stm-read(x): Transaction T_i reads from a version of x with timestamp j such that j is the largest timestamp less than wts_i (among the versions x), i.e. there exists no version k such that $j < k < wts_i$ is true. If no such j exists then T_i is aborted. Otherwise, after reading this version of x , T_i is stored in j 's τl . Then we modify $tltl$, $tutl$ as follows:

1. The version $x[j]$ is created by a transaction with WTS j which is less than wts_i . Hence, $tltl_i = \max(tltl_i, x[j].\text{vrt} + 1)$.
2. Let p be the timestamp of smallest version larger than j . Then $tutl_i = \min(tutl_i, x[p].\text{vrt} - 1)$.
3. After these steps, abort T_i if $tltl$ & $tutl$ have crossed, i.e., $tltl_i > tutl_i$.

stm-write(x, v): T_i stores this write to value x locally in its $wset_i$.

tryC : This operation consists of multiple steps:

1. Before T_i can commit, we need to verify that any object it updates is updated in a consistent manner. When T_i creates a new version, it would be with timestamp wts_i . Hence, T_i needs to make sure that any transaction that read the previous version is unaffected by this new version. Additionally, this would require an update of $tltl$ and $tutl$ of T_i and other transactions whose read-write set overlaps with that of T_i . Specifically, T_i validates each $tobj$ x in its $wset$ as follows:

- (a) T_i finds a version of x with timestamp j such that j is the largest timestamp less than wts_i (like in read). If there exists no version of x with a timestamp less than wts_i then T_i is aborted. This is similar to Step 1b of the tryC of PMVTO algorithm.
- (b) Among all the transactions that have previously read from j suppose there is a transaction T_k such that $j < wts_i < wts_k$. Then (i) if T_k has already committed then T_i is aborted; (ii) Suppose T_k is live and its_k is less than its_i . Then again T_i is aborted; (iii) If T_k is still live with its_i less than its_k then T_k is aborted.

This step is similar to Step 1a of the tryC of PMVTO algorithm.

- (c) Next, we must ensure that T_i has a valid $tltl$ and $tutl$ along with the concurrently executing transactions. To achieve this, we adjust $tltl$, $tutl$ as follows: (i) Let p be the largest version smaller than wts_i . Then $tltl_i = \max(tltl_i, x[p].\text{vrt} + 1)$. Next for each reading transaction, T_r in $x[p].\text{read-list}$, we again set, $tltl_i = \max(tltl_i, tutl_r + 1)$. (ii) Similarly, let q be the smallest version larger than wts_i . Then, $tutl_i = \min(tutl_i, x[q].\text{vrt} - 1)$. (Note that we don't have to check for the transactions in the read-list of $x[q]$ as those transactions will have $tltl$ higher than $x[q].\text{vrt}$ due to *stm-read*.) (iii) Finally, we get the commit time of this transaction from G_tCntr : $comTime_i = G_tCntr.add\&Get(incrVal)$ where $incrVal$ is any constant $\geq 1 + C$. Then, $tutl_i = \min(tutl_i, comTime_i)$. After performing these updates, abort T_i if $tltl$ & $tutl$ have crossed, i.e., $tltl_i > tutl_i$.

2. After performing the tests of Step 1 over each $tobj$ x in T_i 's $wset$, if t_i has not yet been aborted, then for each x in its $wset$: create a vTuple $\langle wts_i, x.v, nil, tutl_i \rangle$. In this tuple, wts_i is the timestamp of the new version; $x.v$ is the value of x is in T_i 's $wset$; the read-list of the vTuple is nil . Update the $vlist$ of each of $tobj$ x similar to Step 2 of tryC of PMVTO.

3. Transaction t_i is then committed.

Step 1c.(iii) of tryC ensures that real-time order between transactions that are not in conflict. For simplicity, we assume C to be 1 in our analysis.

3.5 Data Structures and Pseudocode of KSFTM

The STM system consists of the following methods: $init()$, $tbegin()$, $read(i, x)$, $write_i(i, x, v)$ and $tryC(i)$. We assume that all the $tobj$ s are ordered as x_1, x_2, \dots, x_n and belong to the set \mathcal{T} . We describe the data-structures used by the algorithm.

We start with structures that local to each transaction. Each transaction T_i maintains a $rset_i$ and $wset_i$. In addition it maintains the following structures (1) $comTime_i$: This is value given to T_i when it terminates which is assigned a value in tryC method. (2) A series of lists: smallRL, largeRL, allRL, prevVL, nextVL, reLL, abortRL. The meaning of these lists will be clear with the description of the pseudocode. In addition to these local structures, the following shared global structures are maintained that are shared across transactions (and hence, threads). We name all the shared variable starting with ‘G’.

- G_tCntr (counter): This a numerical valued counter that is incremented when a transaction begins and terminates.

For each transaction T_i we maintain the following shared time-stamps:

- G_lock_i : A lock for accessing all the shared variables of T_i .
- G_its_i (initial timestamp): It is a time-stamp assigned to T_i when it was invoked for the first time without any aborts. The current value of G_tCntr is atomically assigned to it and then incremented. If T_i is aborted and restarts later then the application assigns it the same G_its .
- G_cts_i (current timestamp): It is a time-stamp when T_i is invoked again at a later time after an abort. Like G_its , the current value of G_tCntr is atomically assigned to it and then incremented. When T_i is created for the first time, then its G_cts is same as its G_its .
- G_wts_i (working timestamp): It is the time-stamp that T_i works with. It is either greater than or equal to T_i 's G_cts . It is computed as follows: $G_wts_i = G_cts_i + C * (G_cts_i - G_its_i)$.
- G_valid_i : This is a boolean variable which is initially true. If it becomes false then T_i has to be aborted.
- G_state_i : This is a variable which states the current value of T_i . It has three states: live, committed or aborted.
- G_tttl_i, G_tutl_i (transaction lower & upper time limits): These are the time-limits described in the previous section used to keep the transaction WTS and real-time orders in sync. G_tttl_i is G_cts of T_i when transaction begins and is a non-decreasing value. It continues to increase (or remains same) as T_i reads tobjs and later terminates. G_tutl_i on the other hand is a non-increasing value starting with ∞ when the T_i is created. It reduces (or remains same) as T_i reads tobjs and later terminates. If T_i commits then both G_tttl_i & G_tutl_i are made equal.

Two transactions having the same ITS are said to be incarnations. No two transaction can have the same CTS. For simplicity, we assume that no two transactions have the same WTS as well. In case, two transactions have the same WTS, one can use the tuple $\langle WTS, CTS \rangle$ instead of WTS. But we ignore such cases. For each tobj x in \mathcal{T} , we maintain:

- $x.vl$ (version list): It is a list consisting of version tuples or $vTuple$ of the form $\langle ts, val, rl, vrt \rangle$. The details of the tuple are explained below.
- ts (timestamp): Here ts is the G_wts_i of a committed transaction T_i that has created this version.
- val : The value of this version.
- rl (readList): rl is the read list consists of all the transactions that have read this version. Each entry in this list is of the form $\langle rts \rangle$ where rts is the G_wts_j of a transaction T_j that read this version.
- vrt (version real-time timestamp): It is the G_tutl value (which is same as G_tttl) of the transaction T_i that created this version at the time of commit of T_i .

Algorithm 9 STM $init()$: Invoked at the start of the STM system. Initializes all the tobjs used by the STM System

```

1:  $G_tCntr = 1$ ; /* Global Transaction Counter */
2: for all  $x$  in  $\mathcal{T}$  do /* All the tobjs used by the STM System */
3:   /*  $T_0$  is creating the first version of  $x$ :  $ts = 0, val = 0, rl = nil, vrt = 0$  */
4:   add  $\langle 0, 0, nil, 0 \rangle$  to  $x.vl$ ;
5: end for;

```

Algorithm 10 STM *tbegin(its)*: Invoked by a thread to start a new transaction T_i . Thread can pass a parameter *its* which is the initial timestamp when this transaction was invoked for the first time. If this is the first invocation then *its* is *nil*. It returns the tuple $\langle id, G_wts, G_cts \rangle$

```

1:  $i = \text{unique-id}$ ; /* An unique id to identify this transaction. It could be same as  $G\_cts$  */
2: /* Initialize transaction specific local & global variables */
3: if ( $its == nil$ ) then
4:    $G\_its_i = G\_wts_i = G\_cts_i = G\_tCntr.get\&Inc()$ ; /*  $G\_tCntr.get\&Inc()$  returns the current value of
    $G\_tCntr$  and atomically increments it */
5: else
6:    $G\_its_i = its$ ;
7:    $G\_cts_i = G\_tCntr.get\&Inc()$ ;
8:    $G\_wts_i = G\_cts_i + C * (G\_cts_i - G\_its_i)$ ; /*  $C$  is any constant greater or equal to than 1 */
9: end if
10:  $G\_ttl_i = G\_cts_i$ ;  $G\_tutl_i = comTime_i = \infty$ ;
11:  $G\_state_i = live$ ;  $G\_valid_i = T$ ;
12:  $rset_i = wset_i = nil$ ;
13: return  $\langle i, G\_wts_i, G\_cts_i \rangle$ 

```

Algorithm 11 STM *read(i, x)*: Invoked by a transaction T_i to read tobj x . It returns either the value of x or \mathcal{A}

```

1: if ( $x \in wset_i$ ) then /* Check if the tobj  $x$  is in  $wset_i$  */
2:   return  $wset_i[x].val$ ;
3: else if ( $x \in rset_i$ ) then /* Check if the tobj  $x$  is in  $rset_i$  */
4:   return  $rset_i[x].val$ ;
5: else /* tobj  $x$  is not in  $rset_i$  and  $wset_i$  */
6:   lock  $x$ ; lock  $G\_lock_i$ ;
7:   if ( $G\_valid_i == F$ ) then return abort( $i$ );
8:   end if
9:   /* findLTS: From  $x.vl$ , returns the largest  $ts$  value less than  $G\_wts_i$ . If no such version exists, it returns
    $nil$  */
10:   $curVer = findLTS(G\_wts_i, x)$ ;
11:  if ( $curVer == nil$ ) then return abort( $i$ ); /* Proceed only if  $curVer$  is not  $nil$  */
12:  end if
13:  /* findSTL: From  $x.vl$ , returns the smallest  $ts$  value greater than  $G\_wts_i$ . If no such version exists, it
   returns  $nil$  */
14:   $nextVer = findSTL(G\_wts_i, x)$ ;

```

```

15:  if ( $nextVer \neq nil$ ) then
16:    /* Ensure that  $G\_tutl_i$  remains smaller than  $nextVer$ 's  $vrt$  */
17:     $G\_tutl_i = \min(G\_tutl_i, x[nextVer].vrt - 1)$ ;
18:  end if
19:  /*  $G\_ttl_i$  should be greater than  $x[curVer].vrt$  */
20:   $G\_ttl_i = \max(G\_ttl_i, x[curVer].vrt + 1)$ ;
21:  if ( $G\_ttl_i > G\_tutl_i$ ) then /* If the limits have crossed each other, then  $T_i$  is aborted */
22:    return abort( $i$ );
23:  end if
24:   $val = x[curVer].v$ ; add  $\langle x, val \rangle$  to  $rset_i$ ;
25:  add  $T_i$  to  $x[curVer].rl$ ;
26:  unlock  $G\_lock_i$ ; unlock  $x$ ;
27:  return  $val$ ;
28: end if

```

Algorithm 12 STM $write_i(x, val)$: A Transaction T_i writes into local memory

- 1: Append the $d_tuple\langle x, val \rangle$ to $wset_i$.
 - 2: return ok ;
-

Algorithm 13 STM $tryC()$: Returns ok on commit else return Abort

- 1: /* The following check is an optimization which needs to be performed again later */
 - 2: lock G_lock_i ;
 - 3: **if** ($G_valid_i == F$) **then** return abort(i);
 - 4: **end if**
 - 5: unlock G_lock_i ;
 - 6: /* Initialize smaller read list (smallRL), larger read list (largeRL), all read list (allRL) to nil */
 - 7: $smallRL = largeRL = allRL = nil$;
 - 8: /* Initialize previous version list (prevVL), next version list (nextVL) to nil */
 - 9: $prevVL = nextVL = nil$;
 - 10: **for all** $x \in wset_i$ **do**
 - 11: lock x in pre-defined order;
 - 12: /* findLTS: returns the version of x with the largest τ_s less than G_wts_i . If no such version exists, it returns nil . */
 - 13: $prevVer = findLTS(G_wts_i, x)$; /* prevVer: largest version smaller than G_wts_i */
 - 14: **if** ($prevVer == nil$) **then** /* There exists no version with τ_s value less than G_wts_i */
 - 15: lock G_lock_i ; return abort(i);
 - 16: **end if**
 - 17: $prevVL = prevVL \cup prevVer$; /* prevVL stores the previous version in sorted order */
 - 18: $allRL = allRL \cup x[prevVer].rl$; /* Store the read-list of the previous version */
 - 19: /* **getLar**: obtain the list of reading transactions of $x[prevVer].rl$ whose G_wts is greater than G_wts_i */
 - 20: $largeRL = largeRL \cup getLar(G_wts_i, x[prevVer].rl)$;
 - 21: /* **getSm**: obtain the list of reading transactions of $x[prevVer].rl$ whose G_wts is smaller than G_wts_i */
 - 22: $smallRL = smallRL \cup getSm(G_wts_i, x[prevVer].rl)$;
-

Algorithm 14 $isAborted(T_k)$: Verifies if T_i is already aborted or its G_valid flag is set to false implying that T_i will be aborted soon

- 1: **if** ($G_valid_k == F$) \vee ($G_state_k == abort$) \vee ($T_k \in abortRL$) **then**
 - 2: return T ;
 - 3: **else**
 - 4: return F ;
 - 5: **end if**
-

Algorithm 15 $abort(i)$: Invoked by various STM methods to abort transaction T_i . It returns \mathcal{A}

- 1: $G_valid_i = F$; $G_state_i = abort$;
 - 2: unlock all variables locked by T_i ;
 - 3: return \mathcal{A} ;
-

We get the following nice properties on KSFTM.

Property 5 Any history generated by KSFTM is strict-serializable & loc-opaque.

We have shown the detailed proof of safety in Section 5 of appendix and in [4].

Property 6 KSFTM algorithm ensures starvation-freedom.

```

23:  /* findSTL: returns the version with the smallest  $t_s$  value greater than  $G_{wts_i}$ . If no such version exists,
    it returns  $nil$ . */
24:   $nextVer = findSTL(G_{wts_i}, x)$ ; /*  $nextVer$ : smallest version larger than  $G_{wts_i}$  */
25:  if ( $nextVer \neq nil$ ) then
26:       $nextVL = nextVL \cup nextVer$ ; /*  $nextVL$  stores the next version in sorted order */
27:  end if
28: end for /*  $x \in wset_i$  */
29:  $relLL = allRL \cup T_i$ ; /* Initialize relevant Lock List ( $relLL$ ) */
30: for all ( $T_k \in relLL$ ) do
31:     lock  $G_{lock_k}$  in pre-defined order; /* Note: Since  $T_i$  is also in  $relLL$ ,  $G_{lock_i}$  is also locked */
32: end for
33: /* Verify if  $G_{valid_i}$  is false */
34: if ( $G_{valid_i} == F$ ) then return abort(i);
35: end if
36:  $abortRL = nil$  /* Initialize abort read list ( $abortRL$ ) */
37: /* Among the transactions in  $T_k$  in  $largeRL$ , either  $T_k$  or  $T_i$  has to be aborted */
38: for all ( $T_k \in largeRL$ ) do
39:     if ( $isAborted(T_k)$ ) then
40:         /* Transaction  $T_k$  can be ignored since it is already aborted or about to be aborted */
41:         continue;
42:     end if
43:     if ( $G_{its_i} < G_{its_k}$ )  $\wedge$  ( $G_{state_k} == live$ ) then
44:         /* Transaction  $T_k$  has lower priority and is not yet committed. So it needs to be aborted */
45:          $abortRL = abortRL \cup T_k$ ; /* Store  $T_k$  in  $abortRL$  */
46:     else /* Transaction  $T_i$  has to be aborted */
47:         return abort(i);
48:     end if
49: end for
50: /* Ensure that  $G_{ttl_i}$  is greater than  $vrt$  of the versions in  $prevVL$  */
51: for all ( $ver \in prevVL$ ) do
52:      $x = tobj$  of  $ver$ ;
53:      $G_{ttl_i} = max(G_{ttl_i}, x[ver].vrt + 1)$ ;
54: end for
55: /* Ensure that  $vutl_i$  is less than  $vrt$  of versions in  $nextVL$  */
56: for all ( $ver \in nextVL$ ) do
57:      $x = tobj$  of  $ver$ ;
58:      $G_{tutl_i} = min(G_{tutl_i}, x[ver].vrt - 1)$ ;
59: end for
60: /* Store the current value of the global counter as commit time and increment it */
61:  $comTime_i = G_{tCntr.add\&Get}(incrVal)$ ; /*  $incrVal$  can be any constant  $\geq 1$  */
62:  $G_{tutl_i} = min(G_{tutl_i}, comTime_i)$ ; /* Ensure that  $G_{tutl_i}$  is less than or equal to  $comTime$  */
63: /* Abort  $T_i$  if its limits have crossed */
64: if ( $G_{ttl_i} > G_{tutl_i}$ ) then return abort(i);
65: end if

```

```

66: for all ( $T_k \in \text{smallRL}$ ) do
67:   if ( $\text{isAborted}(T_k)$ ) then
68:     continue;
69:   end if
70:   if ( $G\_ttl_k \geq G\_tutl_i$ ) then /* Ensure that the limits do not cross for both  $T_i$  &  $T_k$  */
71:     if ( $G\_state_k == \text{live}$ ) then /* Check if  $T_k$  is live */
72:       if ( $G\_its_i < G\_its_k$ ) then
73:         /* Transaction  $T_k$  has lower priority and is not yet committed. So it needs to be aborted */
74:          $\text{abortRL} = \text{abortRL} \cup T_k$ ; /* Store  $T_k$  in abortRL */
75:       else /* Transaction  $T_i$  has to be aborted */
76:         return abort(i);
77:       end if /* ( $G\_its_i < G\_its_k$ ) */
78:       else /* ( $T_k$  is committed. Hence,  $T_i$  has to be aborted) */
79:         return abort(i);
80:       end if /* ( $G\_state_k == \text{live}$ ) */
81:     end if /* ( $G\_ttl_k \geq G\_tutl_i$ ) */
82:   end for ( $T_k \in \text{smallRL}$ )
83:   /* After this point  $T_i$  can't abort. */
84:    $G\_ttl_i = G\_tutl_i$ ;
85:   /* Since  $T_i$  can't abort, we can update  $T_k$ 's  $G\_tutl$  */
86:   for all ( $T_k \in \text{smallRL}$ ) do
87:     if ( $\text{isAborted}(T_k)$ ) then
88:       continue;
89:     end if
90:     /* The following line ensure that  $G\_ttl_k \leq G\_tutl_k < G\_ttl_i$ . Note that this does not cause the limits of
       $T_k$  to cross each other because of the check in Line 70.*/
91:      $G\_tutl_k = \min(G\_tutl_k, G\_ttl_i - 1)$ ;
92:   end for
93:   for all  $T_k \in \text{abortRL}$  do /* Abort all the transactions in abortRL since  $T_i$  can't abort */
94:      $G\_valid_k = F$ ;
95:   end for
96:   /* Having completed all the checks,  $T_i$  can be committed */
97:   for all ( $x \in \text{wset}_i$ ) do
98:     /* Create new  $v\_tuple$ :  $ts, val, rl, vrt$  for  $x$  */
99:      $\text{newTuple} = \langle G\_wts_i, \text{wset}_i[x].val, nil, G\_ttl_i \rangle$ ;
100:    if ( $|x.vl| > k$ ) then
101:      replace the oldest tuple in  $x.vl$  with  $\text{newTuple}$ ; /*  $x.vl$  is ordered by  $ts$  */
102:    else
103:      add a  $\text{newTuple}$  to  $x.vl$  in sorted order;
104:    end if
105:  end for /*  $x \in \text{wset}_i$  */
106:   $G\_state_i = \text{commit}$ ;
107:  unlock all variables;
108:  return  $\mathcal{C}$ ;

```

As explained in the description Property 4, the proof of this property is somewhat involved. We have shown the detailed proof of starvation-freedom in Section 6 of appendix and in [4]. The above property is shown in Theorem 51 of Section 6 in the Appendix.

4 Experimental Evaluation

In this section we evaluate the performance of KSFTM and SV-SFTM (single-version starvation freedom algorithm) on Intel(R) Xeon(R) CPU E5-2690 v4 at 2.60GHz (56 cores). We have compared our algorithm KSFTM with the existing SV-SFTM. In order to analyze the performance of KSFTM, we have considered multiple parameters and conclude with the optimal value of K as 10 (described in Appendix 4.1), the optimal value of C as 0.2 (described in Appendix 4.2) and optimal read-write ratio as 50% read and 50% write(described in Appendix 4.3).

4.1 Optimal value of K

We have considered 20 tobjs, 64 number of threads, each thread operates on 5000 transactions and each transaction has 30 operations(50% read and 50% write). We have considered the value of C as 0.1 while varying the value of K from 5 to 30. Figure 8a depicts the optimal value of K is 5.

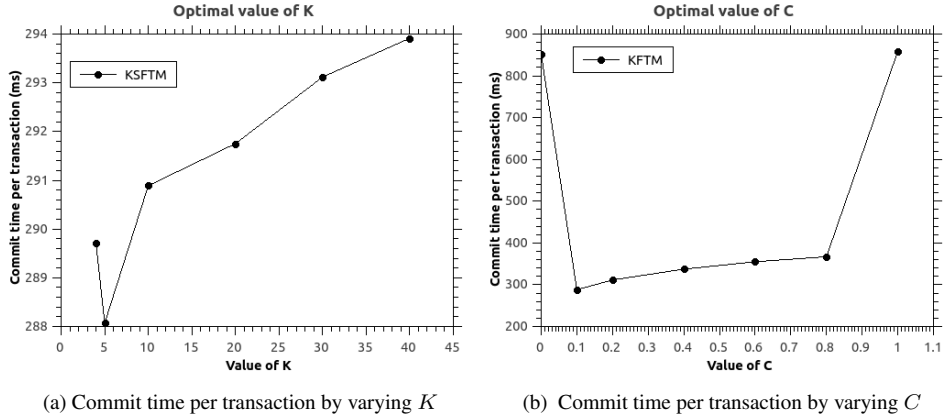

Figure 8: Optimal values of parameters for KSFTM, while commit time per transaction for SV-SFTM is 999.463ms

4.2 Optimal value of C

For calculating the optimal value of C , we have considered K as 5, tobjs count as 20, number of threads as 64, each thread operates on transactions count 5000 and each transaction has 30 operations(50% read and 50% write). Figure 8b represents the execution under KSFTM with the value of C (0, 0.1, 0.2, 0.4, 0.6, 0.8 and 1). Experiment depicts, C as 0.1 is best amongst all, so the optimal value of C is 0.1 .

4.3 Read-write ratio

For obtaining the best read-write ratio, we have considered K as 5 (optimal value of K), C as 0.1 (optimal value of C), tobjs count as 20, number of threads as 64, each thread operates on 5000 transactions and each transaction has 30 operations, while varying the read percentage from 10 to 90.

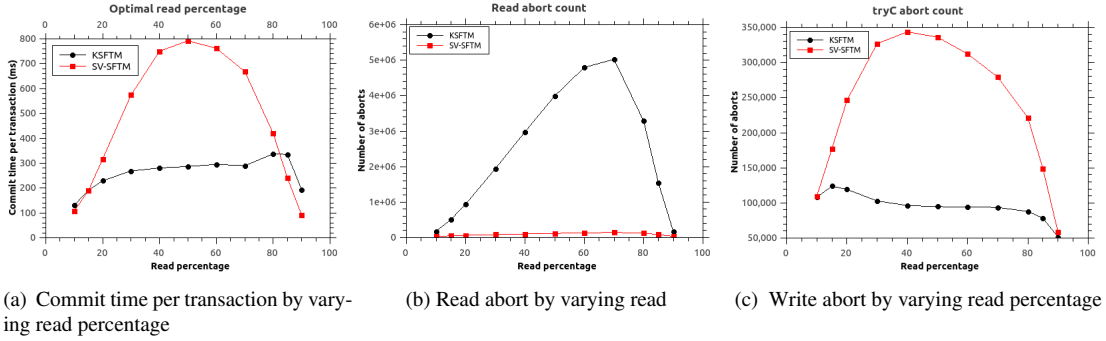

Figure 9: Commit time per transaction, read and tryC abort count with varying read percentage

Figure 9a depicts, KSFTM outperforms SV-SFTM within the range of read percentage varying from 20 to 80. Where KSFTM with read percentage 50 is giving more than twice speedup as compared to SV-SFTM. That implies KSFTM is not only favoring reading transactions but also favours the write transactions. SV-SFTM performs better than KSFTM for read percentage 90, because KSFTM takes time for searching the correct version to read it from and adding itself into the corresponding versions read list at appropriate place, so KSFTM does have version overhead.

Figure 9b and Figure 9c illustrate *read* and *tryC* abort count for KSFTM and SV-SFTM. KSFTM has more *read* abort count than SV-SFTM while SV-SFTM has more *tryC* abort count than KSFTM. This depicts that KSFTM ensures early aborts than allowing the transaction to get aborted at committing stage. These early aborts is one of the reason why KSFTM outperforms SV-SFTM.

4.4 Execution under varying number of transactions

Figure 10a illustrates time taken per thread in milliseconds by KSFTM and SV-SFTM algorithms while varying the number of transactions from 1000 to 5000. Specifically, we have considered 64 threads with read percentage 50, optimal value of K i.e. 5 and C i.e. 0.1. Our experiment shows that KSFTM provides more than 2 fold speedup than SV-SFTM with 5000 transactions.

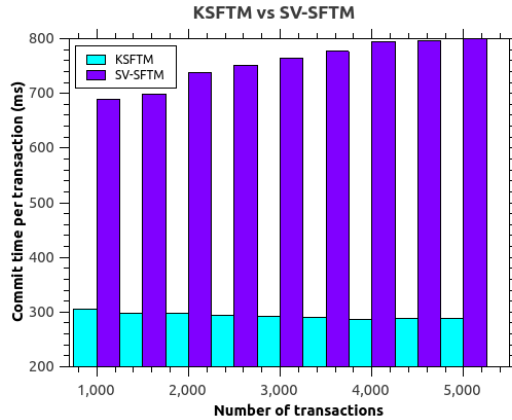

(a) KSFTM vs SV-SFTM

Figure 10: Speedup with varying number of transactions

5 Graph Characterization of Local Opacity & KSFTM Correctness

To prove correctness of STM systems, it is useful to consider graph characterization of histories. In this section, we describe the graph characterization developed by Kumar et al [16] for proving opacity which is based on characterization by Bernstein and Goodman [2]. We extend this characterization for LO.

Consider a history H which consists of multiple versions for each tobj. The graph characterization uses the notion of *version order*. Given H and a tobj x , we define a version order for x as any (non-reflexive) total order on all the versions of x ever created by committed transactions in H . It must be noted that the version order may or may not be the same as the actual order in which the version of x are generated in H . A version order of H , denoted as \ll_H is the union of the version orders of all the tobjs in H .

Consider the history $H2 : r_1(x, 0)r_2(x, 0)r_1(y, 0)r_3(z, 0)w_1(x, 5)w_3(y, 15)w_2(y, 10)w_1(z, 10) c_1c_2r_4(x, 5)r_4(y, 10)w_3(z, 15)c_3r_4(z, 10)$. Using the notation that a committed transaction T_i writing to x creates a version x_i , a possible version order for $H2 \ll_{H2}$ is: $\langle x_0 \ll x_1 \rangle, \langle y_0 \ll y_2 \ll y_3 \rangle, \langle z_0 \ll z_1 \ll z_3 \rangle$.

We define the graph characterization based on a given version order. Consider a history H and a version order \ll . We then define a graph (called opacity graph) on H using \ll , denoted as $OPG(H, \ll) = (V, E)$. The vertex set V consists of a vertex for each transaction T_i in \bar{H} . The edges of the graph are of three kinds and are defined as follows:

1. *real-time*(real-time) edges: If T_i commits before T_j starts in H , then there is an edge from v_i to v_j . This set of edges are referred to as $rt(H)$.
2. *rf*(reads-from) edges: If T_j reads x from T_i in H , then there is an edge from v_i to v_j . Note that in order for this to happen, T_i must have committed before T_j and $c_i <_H r_j(x)$. This set of edges are referred to as $rf(H)$.
3. *mv*(multiversion) edges: The mv edges capture the multiversion relations and is based on the version order. Consider a successful read operation $r_k(x, v)$ and the write operation $w_j(x, v)$ belonging to transaction T_j such that $r_k(x, v)$ reads x from $w_j(x, v)$ (it must be noted T_j is a committed transaction and $c_j <_H r_k$). Consider a committed transaction T_i which writes to x , $w_i(x, u)$ where $u \neq v$. Thus the versions created x_i, x_j are related by \ll . Then, if $x_i \ll x_j$ we add an edge from v_i to v_j . Otherwise ($x_j \ll x_i$), we add an edge from v_k to v_i . This set of edges are referred to as $mv(H, \ll)$.

Using the construction, the $OPG(H2, \ll_{H2})$ for history $H2$ and \ll_{H2} is shown in Figure 11. The edges are annotated. The only mv edge from $T4$ to $T3$ is because of tobjs y, z . $T4$ reads value 5 for z from $T1$ whereas $T3$ also writes 15 to z and commits before $r_4(z)$.

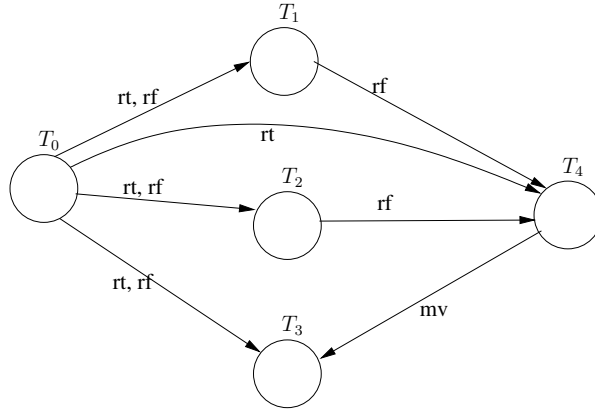

Figure 11: $OPG(H2, \ll_{H2})$

Kumar et al [16] showed that if a version order \ll exists for a history H such that $OPG(H, \ll_H)$ is acyclic, then H is opaque. This is captured in the following result.

Result 7 A valid history H is opaque iff there exists a version order \ll_H such that $OPG(H, \ll_H)$ is acyclic.

This result can be easily extended to prove LO as follows

Theorem 8 A valid history H is loc-opaque iff for each sub-history sh in $H.subhistSet$ there exists a version order \ll_{sh} such that $OPG(sh, \ll_{sh})$ is acyclic. Formally, $\langle (H \text{ is loc-opaque}) \Leftrightarrow (\forall sh \in H.subhistSet, \exists \ll_{sh}: OPG(sh, \ll_{sh}) \text{ is acyclic}) \rangle$.

Proof. To prove this theorem, we have to show that each sub-history sh in $H.subhistSet$ is valid. Then the rest follows from Result 7. Now consider a sub-history sh . Consider any read operation $r_i(x, v)$ of a transaction T_i . It is clear that T_i must have read a version of x created by a previously committed transaction. From the construction of sh , we get that all the transaction that committed before r_i are also in sh . Hence sh is also valid.

Now, proving sh to be opaque iff there exists a version order \ll_{sh} such that $OPG(sh, \ll_{sh})$ is acyclic follows from Result 7.

Lemma 9 Consider a history H in $gen(KSFTM)$ with two transactions T_i and T_j such that both their G_valid flags are true. there is an edge from $T_i \rightarrow T_j$ then $G_tll_i < G_tll_j$.

Proof. There are three types of possible edges in MVSG.

1. Real-time edge: Since, transaction T_i and T_j are in real time order so $comTime_i < G_cts_j$. As we know from Lemma 34 ($G_tll_i \leq comTime_i$). So, ($G_tll_i \leq CTS_j$).
We know from STM $tbegin(its)$ method, $G_tll_j = G_cts_j$.
Eventually, $G_tll_i < G_tll_j$.
2. Read-from edge: Since, transaction T_i has been committed and T_j is reading from T_i so, from Line 99 $tryC(T_i)$, $G_tll_i = vrt_i$.
and from Line 20 STM $read(j, x)$, $G_tll_j = max(G_tll_j, x[curVer].vrt + 1) \Rightarrow (G_tll_j > vrt_i) \Rightarrow (G_tll_j > G_tll_i)$
Hence, $G_tll_i < G_tll_j$.
3. Version-order edge: Consider a triplet $w_j(x_j)r_k(x_j)w_i(x_i)$ in which there are two possibilities of version order:

(a) $i \ll j \implies G_wts_i < G_wts_j$

There are two possibilities of commit order:

- i. $comTime_i <_H comTime_j$: Since, T_i has been committed before T_j so $G_tll_i = vrt_i$. From Line 53 of $tryC(T_j)$, $vrt_i < G_tll(j)$.
Hence, $G_tll_i < G_tll_j$.
- ii. $comTime_j <_H comTime_i$: Since, T_j has been committed before T_i so $G_tll_j = vrt_j$. From Line 58 of $tryC(T_i)$, $G_tutl_i < vrt_j$. As we have assumed G_valid_i is true so definitely it will execute the Line 84 $tryC(T_i)$ i.e. $G_tll_i = G_tutl_i$.
Hence, $G_tll_i < G_tll_j$.

(b) $j \ll i \implies G_wts_j < G_wts_i$

Again, there are two possibilities of commit order:

- i. $comTime_j <_H comTime_i$: Since, T_j has been committed before T_i and T_k read from T_j . There can be two possibilities G_wts_k .
 - A. $G_wts_k > G_wts_i$: That means T_k is in largeRL of T_i . From Line 45 to Line 47 of $tryC(i)$, either transaction T_k or T_i , G_valid flag is set to be false. If T_i returns abort then this case will not be considered in Lemma 9. Otherwise, as T_j has already been committed and later T_i will execute the Line 99 $tryC(T_i)$, Hence, $G_tll_j < G_tll_i$.
 - B. $G_wts_k < G_wts_i$: That means T_k is in smallRL of T_i . From Line 17 of $read(k, x)$, $G_tutl_k < vrt_i$ and from Line 20 of $read(k, x)$, $G_tll_k > vrt_j$. Here, T_j has already been committed so, $G_tll_j = vrt_j$. As we have assumed G_valid_i is true so definitely it will execute the Line 99 $tryC(T_i)$, $G_tll_i = vrt_i$.
So, $G_tutl_k < G_tll_i$ and $G_tll_k > G_tll_j$. While considering G_valid_k flag is true $\rightarrow G_tll_k < G_tutl_k$.
Hence, $G_tll_j < G_tll_k < G_tutl_k < G_tll_i$.
Therefore, $G_tll_j < G_tll_k < G_tll_i$.
- ii. $comTime_i <_H comTime_j$: Since, T_i has been committed before T_j so, $G_tll_i = vrt_i$. From Line 58 of $tryC(T_j)$, $G_tutl_j < vrt_i$ i.e. $G_tutl_j < G_tll_i$. Here, T_k read from T_j . So, From Line 17 of $read(k, x)$, $G_tutl_k < vrt_i \rightarrow G_tutl_k < G_tll_i$ from Line 20 of $read(k, x)$, $G_tll_k > vrt_j$. As we have assumed G_valid_j is true so definitely it will execute the Line 99

$tryC(T_j), G_ttl_j = \text{vrt}_j$.
 Hence, $G_ttl_j < G_ttl_k < G_ttl_k < G_ttl_i$.
 Therefore, $G_ttl_j < G_ttl_k < G_ttl_i$.

Theorem 10 Any history H gen(KSFTM) is local opaque iff for a given version order $\ll H$, $MVSG(H, \ll)$ is acyclic.

Proof. We are proving it by contradiction, so Assuming $MVSG(H, \ll)$ has cycle. From Lemma 9, For any two transactions T_i and T_j such that both their G_valid flags are true and if there is an edge from $T_i \rightarrow T_j$ then $G_ttl_i < G_ttl_j$. While considering transitive case for k transactions $T_1, T_2, T_3 \dots T_k$ such that G_valid flags of all the transactions are true. if there is an edge from $T_1 \rightarrow T_2 \rightarrow T_3 \rightarrow \dots \rightarrow T_k$ then $G_ttl_1 < G_ttl_2 < G_ttl_3 < \dots < G_ttl_k$.

Now, considering our assumption, $MVSG(H, \ll)$ has cycle so, $T_1 \rightarrow T_2 \rightarrow T_3 \rightarrow \dots \rightarrow T_k \rightarrow T_1$ that implies $G_ttl_1 < G_ttl_2 < G_ttl_3 < \dots < G_ttl_k < G_ttl_1$.

Hence from above assumption, $G_ttl_1 < G_ttl_1$ but this is impossible. So, our assumption is wrong.

Therefore, $MVSG(H, \ll)$ produced by KSFTM is acyclic.

M_Order_H : It stands for method order of history H in which methods of transactions are interval (consists of invocation and response of a method) instead of dot (atomic). Because of having method as an interval, methods of different transactions can overlap. To prove the correctness (*local opacity*) of our algorithm, we need to order the overlapping methods.

Let say, there are two transactions T_i and T_j either accessing common (t-objects/ G_lock) or G_tCntr through operations op_i and op_j respectively. If $\text{res}(op_i) <_H \text{inv}(op_j)$ then op_i and op_j are in real-time order in H . So, the M_Order_H is $op_i \rightarrow op_j$.

If operations are overlapping and either accessing common t-objects or sharing G_lock :

1. $read_i(x)$ and $read_j(x)$: If $read_i(x)$ acquires the lock on x before $read_j(x)$ then the M_Order_H is $op_i \rightarrow op_j$.
2. $read_i(x)$ and $tryC_j()$: If they are accessing common t-objects then, let say $read_i(x)$ acquires the lock on x before $tryC_j()$ then the M_Order_H is $op_i \rightarrow op_j$. Now if they are not accessing common t-objects but sharing G_lock then, let say $read_i(x)$ acquires the lock on G_lock_i before $tryC_j()$ acquires the lock on $relLL$ (which consists of G_lock_i and G_lock_j) then the M_Order_H is $op_i \rightarrow op_j$.
3. $tryC_i()$ and $tryC_j()$: If they are accessing common t-objects then, let say $tryC_i()$ acquires the lock on x before $tryC_j()$ then the M_Order_H is $op_i \rightarrow op_j$. Now if they are not accessing common t-objects but sharing G_lock then, let say $tryC_i()$ acquires the lock on $relLL_i$ before $tryC_j()$ then the M_Order_H is $op_i \rightarrow op_j$.

If operations are overlapping and accessing different t-objects but sharing G_tCntr counter:

1. $tbegin_i$ and $tbegin_j$: Both the $tbegin$ are accessing shared counter variable G_tCntr . If $tbegin_i$ executes $G_tCntr.get\&Inc()$ before $tbegin_j$ then the M_Order_H is $op_i \rightarrow op_j$.
2. $tbegin_i$ and $tryC(j)$: If $tbegin_i$ executes $G_tCntr.get\&Inc()$ before $tryC(j)$ then the M_Order_H is $op_i \rightarrow op_j$.

Linearization: The history generated by STMs are generally not sequential because operations of the transactions are overlapping. The correctness of STMs is defined on sequential history, in order to show history generated by our algorithm is correct we have to consider sequential history. We have enough information to order the overlapping methods, after ordering the operations will have equivalent sequential history, the total order of the operation is called linearization of the history.

Operation graph (OPG): Consider each operation as a vertex and edges as below:

1. Real time edge: If response of operation op_i happen before the invocation of operation op_j i.e. $\text{rsp}(op_i) <_H \text{inv}(op_j)$ then there exist real time edge between $op_i \rightarrow op_j$.
2. Conflict edge: It is based on L_Order_H which depends on three conflicts:

- (a) Common *t-object*: If two operations op_i and op_j are overlapping and accessing common *t-object* x . Let say op_i acquire lock first on x then $L_Order.op_i(x) <_H L_Order.op_j(x)$ so, conflict edge is $op_i \rightarrow op_j$.
 - (b) Common *G_valid* flag: If two operation op_i and op_j are overlapping but accessing common *G_valid* flag instead of *t-object*. Let say op_i acquire lock first on G_valid_i then $L_Order.op_i(x) <_H L_Order.op_j(x)$ so, conflict edge is $op_i \rightarrow op_j$.
3. Common *G_tCntr* counter: If two operation op_i and op_j are overlapping but accessing common *G_tCntr* counter instead of *t-object*. Let say op_i access *G_tCntr* counter before op_j then $L_Order.op_i(x) <_H L_Order.op_j(x)$ so, conflict edge is $op_i \rightarrow op_j$.

Lemma 11 All the locks in history H (L_Order_H) gen(KSFTM) follows strict partial order. So, operation graph ($OPG(H)$) is acyclic. If $(op_i \rightarrow op_j)$ in OPG , then atleast one of them will definitely true: $(Fpu_i(\alpha) < Lpl_op_j(\alpha)) \cup (access.G_tCntr_i < access.G_tCntr_j) \cup (Fpu_op_i(\alpha) < access.G_tCntr_j) \cup (access.G_tCntr_i < Lpl_op_j(\alpha))$. Here, α can either be *t-object* or *G_valid*.

Proof. we consider proof by induction, So we assumed there exist a path from op_1 to op_n and there is an edge between op_n to op_{n+1} . As we described, while constructing $OPG(H)$ we need to consider three types of edges. We are considering one by one:

1. Real time edge between op_n to op_{n+1} :

- (a) op_{n+1} is a locking method: In this we are considering all the possible path between op_1 to op_n :
 - i. $(Fu_op_1(\alpha) < Ll_op_n(\alpha))$: Here, $(Fu_op_n(\alpha) < Ll_op_{n+1}(\alpha))$.
So, $(Fu_op_1(\alpha) < Ll_op_n(\alpha)) < (Fu_op_n(\alpha) < Ll_op_{n+1}(\alpha))$
Hence, $(Fu_op_1(\alpha) < Ll_op_{n+1}(\alpha))$
 - ii. $(Fu_op_1(\alpha) < Ll_op_n(\alpha))$: Here, $(access.G_tCntr_n < Ll_op_{n+1}(\alpha))$. As we know if any method is locking as well as accessing common counter then locking tobject first then accessing the counter after that unlocking tobject i.e.
So, $(Ll_op_n(\alpha)) < (access.G_tCntr_n) < (Fu_op_n(\alpha))$.
Hence, $(Fu_op_1(\alpha) < Ll_op_{n+1}(\alpha))$
 - iii. $(access.G_tCntr_1) < (access.G_tCntr_n)$: Here, $(access.G_tCntr_n) < Ll_op_{n+1}(\alpha)$.
So, $(access.G_tCntr_1) < (access.G_tCntr_n) < Ll_op_{n+1}(\alpha)$.
Hence, $(access.G_tCntr_1) < Ll_op_{n+1}(\alpha)$.
 - iv. $(Fu_op_1(\alpha) < (access.G_tCntr_n))$: Here, $(access.G_tCntr_n) < Ll_op_{n+1}(\alpha)$.
So, $(Fu_op_1(\alpha) < (access.G_tCntr_n) < Ll_op_{n+1}(\alpha))$.
Hence, $(Fu_op_1(\alpha) < Ll_op_{n+1}(\alpha))$
 - v. $(access.G_tCntr_1) < Ll_op_n(\alpha)$: Here, $(Fu_op_n(\alpha) < Ll_op_{n+1}(\alpha))$.
So, $(access.G_tCntr_1) < Ll_op_n(\alpha) < (Fu_op_n(\alpha) < Ll_op_{n+1}(\alpha))$.
Hence, $(access.G_tCntr_1) < Ll_op_{n+1}(\alpha)$.
 - vi. $(access.G_tCntr_1) < Ll_op_n(\alpha)$: Here, $(access.G_tCntr_n < Ll_op_{n+1}(\alpha))$. As we know if any method is locking as well as accessing common counter then locking tobject first then accessing the counter after that unlocking tobject i.e.
So, $(Ll_op_n(\alpha)) < (access.G_tCntr_n) < (Fu_op_n(\alpha))$.
Hence, $(access.G_tCntr_1) < Ll_op_{n+1}(\alpha)$.
- (b) op_{n+1} is a non-locking method: Again, we are considering all the possible path between op_1 to op_n :
 - i. $(Fu_op_1(\alpha) < Ll_op_n(\alpha))$: Here, $(access.G_tCntr_n) < (access.G_tCntr_{n+1})$.
As we know if any method is locking as well as accessing common counter then locking tobject first then accessing the counter after that unlocking tobject i.e.
So, $(Ll_op_n(\alpha)) < (access.G_tCntr_n) < (Fu_op_n(\alpha))$.
Hence, $(Fu_op_1(\alpha) < (access.G_tCntr_{n+1}))$
 - ii. $(Fu_op_1(\alpha) < Ll_op_n(\alpha))$: Here, $(Fu_op_n(\alpha) < (access.G_tCntr_{n+1}))$.
So, $(Fu_op_1(\alpha) < Ll_op_n(\alpha)) < (Fu_op_n(\alpha) < (access.G_tCntr_{n+1}))$
Hence, $(Fu_op_1(\alpha) < (access.G_tCntr_{n+1}))$

- iii. $(access.G.tCntr_1) < (access.G.tCntr_n)$: Here, $(access.G.tCntr_n) < (access.G.tCntr_{n+1})$.
So, $(access.G.tCntr_1) < (access.G.tCntr_n) < (access.G.tCntr_{n+1})$.
Hence, $(access.G.tCntr_1) < (access.G.tCntr_{n+1})$.
- iv. $(Fu.op_1(\alpha) < (access.G.tCntr_n))$: Here, $(access.G.tCntr_n) < (access.G.tCntr_{n+1})$.
So, $(Fu.op_1(\alpha) < (access.G.tCntr_n) < (access.G.tCntr_{n+1})$.
Hence, $(Fu.op_1(\alpha) < (access.G.tCntr_{n+1})$
- v. $(access.G.tCntr_1) < Ll.op_n(\alpha)$: Here, $(access.G.tCntr_n) < (access.G.tCntr_{n+1})$.
As we know if any method is locking as well as accessing common counter then locking object first then accessing the counter after that unlocking object i.e.
So, $(Ll.op_n(\alpha) < (access.G.tCntr_n) < (Fu.op_n(\alpha))$.
Hence, $(access.G.tCntr_1) < (access.G.tCntr_{n+1})$.
- vi. $(access.G.tCntr_1) < Ll.op_n(\alpha)$: Here, $(Fu.op_n(\alpha) < (access.G.tCntr_{n+1})$.
So, $(access.G.tCntr_1) < Ll.op_n(\alpha) < (Fu.op_n(\alpha) < (access.G.tCntr_{n+1})$.
Hence, $(access.G.tCntr_1) < (access.G.tCntr_{n+1})$.

2. Conflict edge between op_n to op_{n+1} :

- (a) $(Fu.op_1(\alpha) < Ll.op_n(\alpha))$: Here, $(Fu.op_n(\alpha) < Ll.op_{n+1}(\alpha))$. Ref 1.(a).i.
- (b) $(access.G.tCntr_1) < (access.G.tCntr_n)$: Here, $(Fu.op_n(\alpha) < Ll.op_{n+1}(\alpha))$. As we know if any method is locking as well as accessing common counter then locking object first then accessing the counter after that unlocking object i.e.
So, $(Ll.op_n(\alpha) < (access.G.tCntr_n) < (Fu.op_n(\alpha))$.
Hence, $(access.G.tCntr_1) < Ll.op_{n+1}(\alpha)$.
- (c) $(Fu.op_1(\alpha) < (access.G.tCntr_n))$: Here, $(Fu.op_n(\alpha) < Ll.op_{n+1}(\alpha))$. As we know if any method is locking as well as accessing common counter then locking object first then accessing the counter after that unlocking object i.e.
So, $(Ll.op_n(\alpha) < (access.G.tCntr_n) < (Fu.op_n(\alpha))$.
Hence, $(Fu.op_1(\alpha) < Ll.op_{n+1}(\alpha))$.
- (d) $(access.G.tCntr_1) < Ll.op_n(\alpha)$: Here, $(Fu.op_n(\alpha) < Ll.op_{n+1}(\alpha))$.
Ref 1.(a).v.

3. Common counter edge between op_n to op_{n+1} :

- (a) $(Fu.op_1(\alpha) < Ll.op_n(\alpha))$: Here, $(access.G.tCntr_n) < (access.G.tCntr_{n+1})$. As we know if any method is locking as well as accessing common counter then locking object first then accessing the counter after that unlocking object i.e.
So, $(Ll.op_n(\alpha) < (access.G.tCntr_n) < (Fu.op_n(\alpha))$.
Hence, $(Fu.op_1(\alpha) < (access.G.tCntr_{n+1})$.
- (b) $(access.G.tCntr_1) < (access.G.tCntr_n)$: Here, $(access.G.tCntr_n) < (access.G.tCntr_{n+1})$. Ref 1.(b).iii.
- (c) $(Fu.op_1(\alpha) < (access.G.tCntr_n))$: Here, $(access.G.tCntr_n) < (access.G.tCntr_{n+1})$. Ref 1.(b).iv.
- (d) $(access.G.tCntr_1) < Ll.op_n(\alpha)$: Here, $(access.G.tCntr_n) < (access.G.tCntr_{n+1})$. Ref 1.(b).v

Therefore, OPG(H, M_Order) produced by KSFTM is acyclic.

Lemma 12 Any history H gen(KSFTM) with α linearization such that it respects M_Order_H then (H, α) is valid.

Proof. From the definition of *valid history*: If all the read operations of H is reading from the previously committed transaction T_j then H is valid.

In order to prove H is valid, we are analyzing the read(i,x). so, from Line 10, it returns the largest t_s value less than G_wts_i that has already been committed and return the value successfully. If such version created by transaction T_j found then T_i read from T_j . Otherwise, if there is no version whose WTS is less than T_i 's WTS, then T_i returns abort.

Now, consider the base case read(i,x) is the first transaction T_1 and none of the transactions has been created a version then as we have assumed, there always exist T_0 by default that has been created a version for all t-objects.

Hence, T_1 reads from committed transaction T_0 .

So, all the reads are reading from largest t_s value less than G_wts_i that has already been committed. Hence, (H, α) is valid.

Lemma 13 Any history H gen(KSFTM) with α and β linearization such that both respects M_Order_H i.e. $M_Order_H \subseteq \alpha$ and $M_Order_H \subseteq \beta$ then $\prec_{(H,\alpha)}^{RT} = \prec_{(H,\beta)}^{RT}$.

Proof. Consider a history H gen(KSFTM) such that two transactions T_i and T_j are in real time order which respects M_Order_H i.e. $tryC_i < tbegin_j$. As α and β are linearizations of H so, $tryC_i <_{(H,\alpha)} tbegin_j$ and $tryC_i <_{(H,\beta)} tbegin_j$. Hence in both the cases of linearizations, T_i committed before begin of T_j . So, $\prec_{(H,\alpha)}^{RT} = \prec_{(H,\beta)}^{RT}$.

Lemma 14 Any history H gen(KSFTM) with α and β linearization such that both respects M_Order_H i.e. $M_Order_H \subseteq \alpha$ and $M_Order_H \subseteq \beta$ then (H, α) is local opaque iff (H, β) is local opaque.

Proof. As α and β are linearizations of history H gen(KSFTM) so, from Lemma 12 (H, α) and (H, β) are valid histories.

Now assuming (H, α) is local opaque so we need to show (H, β) is also local opaque. Since (H, α) is local opaque so there exists legal t-sequential history S (with respect to each aborted transactions and last committed transaction while considering only committed transactions) which is equivalent to (\overline{H}, α) . As we know β is a linearization of H so (\overline{H}, β) is equivalent to some legal t-sequential history S . From the definition of local opacity $\prec_{(H,\alpha)}^{RT} \subseteq \prec_S^{RT}$. From Lemma 13, $\prec_{(H,\alpha)}^{RT} = \prec_{(H,\beta)}^{RT}$ that implies $\prec_{(H,\beta)}^{RT} \subseteq \prec_S^{RT}$. Hence, (H, β) is local opaque.

Now consider the other way in which (H, β) is local opaque and we need to show (H, α) is also local opaque. We can prove it while giving the same argument as above, by exchanging α and β .

Hence, (H, α) is local opaque iff (H, β) is local opaque.

Theorem 15 Any history generated by KSFTM is loc-opaque.

Proof. For proving this, we consider a sequential history H generated by KSFTM. We define the version order \ll_{vrt} : for two versions v_i, v_j it is defined as

$$(v_i \ll_{vrt} v_j) \equiv (v_i.vrt < v_j.vrt)$$

Using this version order \ll_{vrt} , we can show that all the sub-histories in $H.subhistSet$ are acyclic.

Since the histories generated by KSFTM are loc-opaque, we get that they are also strict-serializable.

Corollary 16 Any history generated by KSFTM is strict-serializable.

6 Proof of Liveness

Proof Notations: Let $gen(KSFTM)$ consist of all the histories accepted by KSFTM algorithm. In the follow sub-section, we only consider histories that are generated by KSFTM unless explicitly stated otherwise. For simplicity, we only consider sequential histories in our discussion below.

Consider a transaction T_i in a history H generated by KSFTM. Once it executes $tbegin$ method, its ITS, CTS, WTS values do not change. Thus, we denote them as its_i, cts_i, wts_i respectively for T_i . In case the context of the history H in which the transaction executing is important, we denote these variables as $H.its_i, H.cts_i, H.wts_i$ respectively.

The other variables that a transaction maintains are: ttl , $tutl$, $lock$, $valid$, $state$. These values change as the execution proceeds. Hence, we denote them as: $H.ttl_i, H.tutl_i, H.lock_i, H.valid_i, H.state_i$. These represent the values of ttl , $tutl$, $lock$, $valid$, $state$ after the execution of last event in H . Depending on the context, we sometimes ignore H and denote them only as: $lock_i, valid_i, state_i, ttl_i, tutl_i$.

We approximate the system time with the value of $tCntr$. We denote the sys-time of history H as the value of $tCntr$ immediately after the last event of H . Further, we also assume that the value of C is 1 in our arguments. But, it can be seen that the proof will work for any value greater than 1 as well.

The application invokes transactions in such a way that if the current T_i transaction aborts, it invokes a new transaction T_j with the same ITS. We say that T_i is an *incarnation* of T_j in a history H if $H.its_i = H.its_j$. Thus the multiple incarnations of a transaction T_i get invoked by the application until an incarnation finally commits.

To capture this notion of multiple transactions with the same ITS, we define *incarSet* (incarnation set) of T_i in H as the set of all the transactions in H which have the same ITS as T_i and includes T_i as well. Formally,

$$H.incarSet(T_i) = \{T_j | (T_i = T_j) \vee (H.its_i = H.its_j)\}$$

Note that from this definition of *incarSet*, we implicitly get that T_i and all the transactions in its *incarSet* of H also belong to H . Formally, $H.incarSet(T_i) \in H.txns$.

The application invokes different incarnations of a transaction T_i in such a way that as long as an incarnation is live, it does not invoke the next incarnation. It invokes the next incarnation after the current incarnation has got aborted. Once an incarnation of T_i has committed, it can't have any future incarnations. Thus, the application views all the incarnations of a transaction as a single *application-transaction*.

We assign *incNums* to all the transactions that have the same ITS. We say that a transaction T_i starts *afresh*, if $T_i.incNum$ is 1. We say that T_i is the nextInc of T_j if T_j and T_i have the same ITS and T_i 's *incNum* is T_j 's *incNum* + 1. Formally, $\langle (T_i.nextInc = T_j) \equiv (its_i = its_j) \wedge (T_i.incNum = T_j.incNum + 1) \rangle$

As mentioned the objective of the application is to ensure that every application-transaction eventually commits. Thus, the applications views the entire *incarSet* as a single application-transaction (with all the transactions in the *incarSet* having the same ITS). We can say that an application-transaction has committed if in the corresponding *incarSet* a transaction in eventually commits. For T_i in a history H , we denote this by a boolean value *incarCt* (incarnation set committed) which implies that either T_i or an incarnation of T_i has committed. Formally, we define it as $H.incarCt(T_i)$

$$H.incarCt(T_i) = \begin{cases} True & (\exists T_j : (T_j \in H.incarSet(T_i)) \wedge (T_j \in H.committed)) \\ False & \text{otherwise} \end{cases}$$

From the definition of *incarCt* we get the following observations & lemmas about a transaction T_i

Observation 17 Consider a transaction T_i in a history H with its *incarCt* being true in H . Then T_i is terminated (either committed or aborted) in H . Formally, $\langle H, T_i : (T_i \in H.txns) \wedge (H.incarCt(T_i)) \implies (T_i \in H.terminated) \rangle$.

Observation 18 Consider a transaction T_i in a history H with its *incarCt* being true in $H1$. Let $H2$ be a extension of $H1$ with a transaction T_j in it. Suppose T_j is an incarnation of T_i . Then T_j 's *incarCt* is true in $H2$. Formally, $\langle H1, H2, T_i, T_j : (H1 \sqsubseteq H2) \wedge (H1.incarCt(T_i)) \wedge (T_j \in H2.txns) \wedge (T_i \in H2.incarSet(T_j)) \implies (H2.incarCt(T_j)) \rangle$.

Lemma 19 Consider a history $H1$ with a strict extension $H2$. Let T_i & T_j be two transactions in $H1$ & $H2$ respectively. Let T_j not be in $H1$. Suppose T_i 's *incarCt* is true. Then ITS of T_i cannot be the same as ITS of T_j . Formally, $\langle H1, H2, T_i, T_j : (H1 \sqsubset H2) \wedge (H1.incarCt(T_i)) \wedge (T_j \in H2.txns) \wedge (T_j \notin H1.txns) \implies (H1.its_i \neq H2.its_j) \rangle$.

Proof. Here, we have that T_i 's *incarCt* is true in $H1$. Suppose T_j is an incarnation of T_i , i.e., their ITSs are the same. We are given that T_j is not in $H1$. This implies that T_j must have started after the last event of $H1$.

We are also given that T_i 's *incarCt* is true in $H1$. This implies that an incarnation of T_i or T_i itself has committed in $H1$. After this commit, the application will not invoke another transaction with the same ITS as T_i . Thus, there cannot be a transaction after the last event of $H1$ and in any extension of $H1$ with the same ITS of T_i . Hence, $H1.its_i$ cannot be same as $H2.its_j$.

Now we show the liveness with the following observations, lemmas & theorems. We start with two observations about that histories of which one is an extension of the other. The following states that for any history, there exists an extension. In other words, we assume that the STM system runs forever and does not terminate. This is required for showing that every transaction eventually commits.

Observation 20 Consider a history $H1$ generated by *gen(KSFTM)*. Then there is a history $H2$ in *gen(KSFTM)* such that $H2$ is a strict extension of $H1$. Formally, $\langle \forall H1 : (H1 \in gen(ksftm)) \implies (\exists H2 : (H2 \in gen(ksftm)) \wedge (H1 \sqsubset H2)) \rangle$.

The follow observation is about the transaction in a history and any of its extensions.

Observation 21 Given two histories $H1$ & $H2$ such that $H2$ is an extension of $H1$. Then, the set of transactions in $H1$ are a subset equal to the set of transaction in $H2$. Formally, $\langle \forall H1, H2 : (H1 \sqsubseteq H2) \implies (H1.txns \subseteq H2.txns) \rangle$.

In order for a transaction T_i to commit in a history H , it has to compete with all the live transactions and all the aborted that can become live again as a different incarnation. Once a transaction T_j aborts, another incarnation of T_j can start and become live again. Thus T_i will have to compete with this incarnation of T_j later. Thus, we have the following observation about aborted & committed transactions.

Observation 22 Consider an aborted transaction T_i in a history $H1$. Then there is an extension of $H1$, $H2$ in which an incarnation of T_i, T_j is live and has cts_j is greater than cts_i . Formally, $\langle H1, T_i : (T_i \in H1.aborted) \implies (\exists T_j, H2 : (H1 \sqsubseteq H2) \wedge (T_j \in H2.live) \wedge (H2.its_i = H2.its_j) \wedge (H2.cts_i < H2.cts_j)) \rangle$.

Observation 23 Consider an committed transaction T_i in a history $H1$. Then there is no extension of $H1$, in which an incarnation of T_i, T_j is live. Formally, $\langle H1, T_i : (T_i \in H1.committed) \implies (\nexists T_j, H2 : (H1 \sqsubseteq H2) \wedge (T_j \in H2.live) \wedge (H2.its_i = H2.its_j)) \rangle$.

Lemma 24 Consider a history $H1$ and its extension $H2$. Let T_i, T_j be in $H1, H2$ respectively such that they are incarnations of each other. If WTS of T_i is less than WTS of T_j then CTS of T_i is less than CTS T_j . Formally, $\langle H1, H2, T_i, T_j : (H1 \sqsubseteq H2) \wedge (T_i \in H1.txns) \wedge (T_j \in H2.txns) \wedge (T_i \in H2.incarSet(T_j)) \wedge (H1.wts_i < H2.wts_j) \implies (H1.cts_i < H2.cts_j) \rangle$

Proof. Here we are given that

$$H1.wts_i < H2.wts_j \tag{1}$$

The definition of WTS of T_i is: $H1.wts_i = H1.cts_i + C * (H1.cts_i - H1.its_i)$. Combining this Eqn(1), we get that

$$(C+1)*H1.cts_i - C*H1.its_i < (C+1)*H2.cts_j - C*H2.its_j \xrightarrow[\text{H1.its}_i = \text{H2.its}_j]{\text{T}_i \in \text{H2.incarSet}(\text{T}_j)} H1.cts_i < H2.cts_j.$$

Lemma 25 Consider a live transaction T_i in a history $H1$ with its wts_i less than a constant α . Then there is a strict extension of $H1$, $H2$ in which an incarnation of T_i, T_j is live with WTS greater than α . Formally, $\langle H1, T_i : (T_i \in H1.live) \wedge (H1.wts_i < \alpha) \implies (\exists T_j, H2 : (H1 \sqsubseteq H2) \wedge (T_i \in H2.incarSet(T_j)) \wedge ((T_j \in H2.committed) \vee ((T_j \in H2.live) \wedge (H2.wts_j > \alpha)))) \rangle$.

Proof. The proof comes the behavior of an application-transaction. The application keeps invoking a transaction with the same ITS until it commits. Thus the transaction T_i which is live in $H1$ will eventually terminate with an abort or commit. If it commits, $H2$ could be any history after the commit of T_2 .

On the other hand if T_i is aborted, as seen in Observation 22 it will be invoked again or reincarnated with another CTS and WTS. It can be seen that CTS is always increasing. As a result, the WTS is also increasing. Thus eventually the WTS will become greater α . Hence, we have that either an incarnation of T_i will get committed or will eventually have WTS greater than or equal to α .

Next we have a lemma about CTS of a transaction and the sys-time of a history.

Lemma 26 Consider a transaction T_i in a history H . Then, we have that CTS of T_i will be less than or equal to sys-time of H . Formally, $\langle T_i, H1 : (T_i \in H.txns) \implies (H.cts_i \leq H.sys-time) \rangle$.

Proof. We get this lemma by observing the methods of the STM System that increment the tCntr which are tbegin and tryC. It can be seen that CTS of T_i gets assigned in the tbegin method. So if the last method of H is the tbegin of T_i then we get that CTS of T_i is same as sys-time of H . On the other hand if some other method got executed in H after tbegin of T_i then we have that CTS of T_i is less than sys-time of H . Thus combining both the cases, we get that CTS of T_i is less than or equal to as sys-time of H , i.e., $(H.cts_i \leq H.sys-time)$

From this lemma, we get the following corollary which is the converse of the lemma statement

Corollary 27 Consider a transaction T_i which is not in a history $H1$ but in an strict extension of $H1$, $H2$. Then, we have that CTS of T_i is greater than the sys-time of H . Formally, $\langle T_i, H1, H2 : (H1 \sqsubset H2) \wedge (T_i \notin H1.txns) \wedge (T_i \in H2.txns) \implies (H2.cts_i > H1.sys-time) \rangle$.

Now, we have lemma about the methods of KSFTM completing in finite time.

Lemma 28 *If all the locks are fair and the underlying system scheduler is fair then all the methods of KSFTM will eventually complete.*

Proof. It can be seen that in any method, whenever a transaction T_i obtains multiple locks, it obtains locks in the same order: first lock relevant to T_i in a pre-defined order and then lock relevant to T_i again in a predefined order. Since all the locks are obtained in the same order, it can be seen that the methods of KSFTM will not deadlock.

It can also be seen that none of the methods have any unbounded while loops. All the loops in tryC method iterate through all the tobj in the write-set of T_i . Moreover, since we assume that the underlying scheduler is fair, we can see that no thread gets swapped out infinitely. Finally, since we assume that all the locks are fair, it can be seen all the methods terminate in finite time.

Theorem 29 *Every transaction either commits or aborts in finite time.*

Proof. This theorem comes directly from the Lemma 28. Since every method of KSFTM will eventually complete, all the transactions will either commit or abort in finite time.

From this theorem, we get the following corollary which states that the maximum *lifetime* of any transaction is L .

Corollary 30 *Any transaction T_i in a history H will either commit or abort before the sys-time of H crosses $cts_i + L$.*

The following lemma connects WTS and ITS of two transactions, T_i, T_j .

Lemma 31 *Consider a history $H1$ with two transactions T_i, T_j . Let T_i be in $H1.live$. Suppose T_j 's WTS is greater or equal to T_i 's WTS. Then ITS of T_j is less than $its_i + 2 * L$. Formally, $\langle H, T_i, T_j : (\{T_i, T_j\} \subseteq H.txns) \wedge (T_i \in H.live) \wedge (H.wts_j \geq H.wts_i) \implies (H.its_i + 2L \geq H.its_j) \rangle$.*

Proof. Since T_i is live in $H1$, from Corollary 30, we get that it terminates before the system time, $tCntr$ becomes $cts_i + L$. Thus, sys-time of history $H1$ did not progress beyond $cts_i + L$. Hence, for any other transaction T_j (which is either live or terminated) in $H1$, it must have started before sys-time has crossed $cts_i + L$. Formally $\langle cts_j \leq cts_i + L \rangle$.

Note that we have defined WTS of a transaction T_j as: $wts_j = (cts_j + C * (cts_j - its_j))$. Now, let us consider the difference of the WTSs of both the transactions.

$$\begin{aligned} wts_j - wts_i &= (cts_j + C * (cts_j - its_j)) - (cts_i + C * (cts_i - its_i)) \\ &= (C + 1)(cts_j - cts_i) - C(its_j - its_i) \\ &\leq (C + 1)L - C(its_j - its_i) \quad [\because cts_j \leq cts_i + L] \\ &= 2 * L + its_i - its_j \quad [\because C = 1] \end{aligned}$$

Thus, we have that: $\langle (its_i + 2L - its_j) \geq (wts_j - wts_i) \rangle$. This gives us that

$$\langle (wts_j - wts_i) \geq 0 \rangle \implies \langle (its_i + 2L - its_j) \geq 0 \rangle.$$

From the above implication we get that, $\langle wts_j \geq wts_i \rangle \implies \langle its_i + 2L \geq its_j \rangle$.

It can be seen that KSFTM algorithm gives preference to transactions with lower ITS to commit. To understand this notion of preference, we define a few notions of enablement of a transaction T_i in a history H . We start with the definition of *itsEnabled* as:

Definition 1 *We say T_i is itsEnabled in H if for all transactions T_j with ITS lower than ITS of T_i in H have *incarCt* to be true. Formally,*

$$H.itsEnabled(T_i) = \begin{cases} True & (T_i \in H.live) \wedge (\forall T_j \in H.txns : (H.its_j < H.its_i) \implies (H.incarCt(T_j))) \\ False & otherwise \end{cases}$$

The follow lemma states that once a transaction T_i becomes itsEnabled it continues to remain so until it terminates.

Lemma 32 *Consider two histories $H1$ and $H2$ with $H2$ being a extension of $H1$. Let a transaction T_i being live in both of them. Suppose T_i is itsEnabled in $H1$. Then T_i is itsEnabled in $H2$ as well. Formally, $\langle H1, H2, T_i : (H1 \sqsubseteq H2) \wedge (T_i \in H1.live) \wedge (T_i \in H2.live) \wedge (H1.itsEnabled(T_i)) \implies (H2.itsEnabled(T_i)) \rangle$.*

Proof. When T_i begins in a history $H3$ let the set of transactions with ITS less than its_i be $smIts$. Then in any extension of $H3$, $H4$ the set of transactions with ITS less than its_i remains as $smIts$.

Suppose $H1, H2$ are extensions of $H3$. Thus in $H1, H2$ the set of transactions with ITS less than its_i will be $smIts$. Hence, if T_i is `itsEnabled` in $H1$ then all the transactions T_j in $smIts$ are $H1.incarCt(T_j)$. It can be seen that this continues to remain true in $H2$. Hence in $H2$, T_i is also `itsEnabled` which proves the lemma.

The following lemma deals with a committed transaction T_i and any transaction T_j that terminates later. In the following lemma, $incrVal$ is any constant greater than or equal to 1.

Lemma 33 Consider a history H with two transactions T_i, T_j in it. Suppose transaction T_i commits before T_j terminates (either by commit or abort) in H . Then $comTime_i$ is less than $comTime_j$ by at least $incrVal$. Formally, $\langle H, \{T_i, T_j\} \in H.txns : (tryC_i <_H term-op_j) \implies (comTime_i + incrVal \leq comTime_j) \rangle$.

Proof. When T_i commits, let the value of the global $tCntr$ be α . It can be seen that in `tbegin` method, $comTime_j$ get initialized to ∞ . The only place where $comTime_j$ gets modified is at Line 61 of `tryC`. Thus if T_j gets aborted before executing `tryC` method or before this line of `tryC` we have that $comTime_j$ remains at ∞ . Hence in this case we have that $\langle comTime_i + incrVal < comTime_j \rangle$.

If T_j terminates after executing Line 61 of `tryC` method then $comTime_j$ is assigned a value, say β . It can be seen that β will be greater than α by at least $incrVal$ due to the execution of this line. Thus, we have that $\langle \alpha + incrVal \leq \beta \rangle$

The following lemma connects the `G.ttl` and `comTime` of a transaction T_i .

Lemma 34 Consider a history H with a transaction T_i in it. Then in H , ttl_i will be less than or equal to $comTime_i$. Formally, $\langle H, \{T_i\} \in H.txns : (H.ttl_i \leq H.comTime_i) \rangle$.

Proof. Consider the transaction T_i . In `tbegin` method, $comTime_i$ get initialized to ∞ . The only place where $comTime_i$ gets modified is at Line 61 of `tryC`. Thus if T_i gets aborted before this line or if T_i is live we have that $\langle ttl_i \leq comTime_i \rangle$. On executing Line 61, $comTime_i$ gets assigned to some finite value and it does not change after that.

It can be seen that ttl_i gets initialized to cts_i in Line 4 of `tbegin` method. In that line, cts_i reads $tCntr$ and increments it atomically. Then in Line 61, $comTime_i$ gets assigned the value of $tCntr$ after incrementing it. Thus, we clearly get that $cts_i (= ttl_i \text{ initially}) < comTime_i$. Then ttl_i gets updated on Line 20 of `read`, Line 53 and Line 84 of `tryC` methods. Let us analyze them case by case assuming that ttl_i was last updated in each of these methods before the termination of T_i :

1. Line 20 of `read` method: Suppose this is the last line where ttl_i updated. Here ttl_i gets assigned to $1 + vrt$ of the previously committed version which say was created by a transaction T_j . Thus, we have the following equation,

$$ttl_i = 1 + x[j].vrt \quad (2)$$

It can be seen that $x[j].vrt$ is same as ttl_j when T_j executed Line 99 of `tryC`. Further, ttl_j in turn is same as $tutl_j$ due to Line 84 of `tryC`. From Line 62, it can be seen that $tutl_j$ is less than or equal to $comTime_j$ when T_j committed. Thus we have that

$$x[j].vrt = ttl_j = tutl_j \leq comTime_j \quad (3)$$

It is clear that from the above discussion that T_j executed `tryC` method before T_i terminated (i.e. $tryC_j <_{H1} term-op_i$). From Eqn(2) and Eqn(3), we get

$$ttl_i \leq 1 + comTime_j \xrightarrow{incrVal \geq 1} ttl_i \leq incrVal + comTime_j \xrightarrow{\text{Lemma 33}} ttl_i \leq comTime_i$$

2. Line 53 of `tryC` method: The reasoning in this case is very similar to the above case.
3. Line 84 of `tryC` method: In this line, ttl_i is made equal to $tutl_i$. Further, in Line 62, $tutl_i$ is made lesser than or equal to $comTime_i$. Thus combing these, we get that $ttl_i \leq comTime_i$. It can be seen that the reasoning here is similar in part to Case 1.

Hence, in all the three cases we get that $\langle ttl_i \leq comTime_i \rangle$.

The following lemma connects the `G.tutl`, `comTime` of a transaction T_i with `WTS` of a transaction T_j that has already committed.

Lemma 35 Consider a history H with a transaction T_i in it. Suppose $tutl_i$ is less than $comTime_i$. Then, there is a committed transaction T_j in H such that wts_j is greater than wts_i . Formally, $\langle H \in gen(KSFTM), \{T_i\} \in H.txns : (H.tutl_i < H.comTime_i) \implies (\exists T_j \in H.committed : H.wts_j > H.wts_i) \rangle$.

Proof. It can be seen that $G.tutl_i$ initialized in `tbegin` method to ∞ . $tutl_i$ is updated in Line 17 of `read` method, Line 58 & Line 62 of `tryC` method. If T_i executes Line 17 of `read` method and/or Line 58 of `tryC` method then $tutl_i$ gets decremented to some value less than ∞ , say α . Further, it can be seen that in both these lines the value of $tutl_i$ is possibly decremented from ∞ because of `nextVer` (or `ver`), a version of x whose τs is greater than T_i 's WTS. This implies that some transaction T_j , which is committed in H , must have created `nextVer` (or `ver`) and $wts_j > wts_i$.

Next, let us analyze the value of α . It can be seen that $\alpha = x[nextVer/ver].vrt - 1$ where `nextVer/ver` was created by T_j . Further, we can see when T_j executed `tryC`, we have that $x[nextVer].vrt = tttl_j$ (from Line 99). From Lemma 34, we get that $tttl_j \leq comTime_j$. This implies that $\alpha < comTime_j$. Now, we have that T_j has already committed before the termination of T_i . Thus from Lemma 33, we get that $comTime_j < comTime_i$. Hence, we have that,

$$\alpha < comTime_i \tag{4}$$

Now let us consider Line 62 executed by T_i which causes $tutl_i$ to change. This line will get executed only after both Line 17 of `read` method, Line 58 of `tryC` method. This is because every transaction executes `tryC` method only after `read` method. Further within `tryC` method, Line 62 follows Line 58.

There are two sub-cases depending on the value of $tutl_i$ before the execution of Line 62: (i) If $tutl_i$ was ∞ and then get decremented to $comTime_i$ upon executing this line, then we get $comTime_i = tutl_i$. From Eqn(4), we can ignore this case. (ii) Suppose the value of $tutl_i$ before executing Line 62 was α . Then from Eqn(4) we get that $tutl_i$ remains at α on execution of Line 62. This implies that a transaction T_j committed such that $wts_j > wts_i$. The following lemma connects the $G.ttl$ of a committed transaction T_j and `comTime` of a transaction T_i that commits later.

Lemma 36 Consider a history $H1$ with transactions T_i, T_j in it. Suppose T_j is committed and T_i is live in $H1$. Then in any extension of $H1$, say $H2$, $tttl_j$ is less than or equal to $comTime_i$. Formally, $\langle H1, H2 \in gen(KSFTM), \{T_i, T_j\} \subseteq H1, H2.txns : (H1 \sqsubseteq H2) \wedge (T_j \in H1.committed) \wedge (T_i \in H1.live) \implies (H2.tttl_j < H2.comTime_i) \rangle$.

Proof. As observed in the previous proof of Lemma 34, if T_i is live or aborted in $H2$, then its `comTime` is ∞ . In both these cases, the result follows.

If T_i is committed in $H2$ then, one can see that `comTime` of T_i is not ∞ . In this case, it can be seen that T_j committed before T_i . Hence, we have that $comTime_j < comTime_i$. From Lemma 34, we get that $tttl_j \leq comTime_j$. This implies that $tttl_j < comTime_i$.

In the following sequence of lemmas, we identify the condition by when a transaction will commit.

Lemma 37 Consider two histories $H1, H3$ such that $H3$ is a strict extension of $H1$. Let T_i be a transaction in $H1.live$ such that T_i `itsEnabled` in $H1$ and $G.valid_i$ flag is true in $H1$. Suppose T_i is aborted in $H3$. Then there is a history $H2$ which is an extension of $H1$ (and could be same as $H1$) such that (1) Transaction T_i is live in $H2$; (2) there is a transaction T_j that is live in $H2$; (3) $H2.wts_j$ is greater than $H2.wts_i$; (4) T_j is committed in $H3$. Formally, $\langle H1, H3, T_i : (H1 \sqsubset H3) \wedge (T_i \in H1.live) \wedge (H1.valid_i = True) \wedge (H1.itsEnabled(T_i)) \wedge (T_i \in H3.aborted) \implies (\exists H2, T_j : (H1 \sqsubseteq H2 \sqsubset H3) \wedge (T_i \in H2.live) \wedge (T_j \in H2.txns) \wedge (H2.wts_i < H2.wts_j) \wedge (T_j \in H3.committed)) \rangle$.

Proof. To show this lemma, w.l.o.g we assume that T_i on executing either `read` or `tryC` in $H2$ (which could be same as $H1$) gets aborted resulting in $H3$. Thus, we have that T_i is live in $H2$. Here T_i is `itsEnabled` in $H1$. From Lemma 32, we get that T_i is `itsEnabled` in $H2$ as well.

Let us sequentially consider all the lines where a T_i could abort. In $H2$, T_i executes one of the following lines and is aborted in $H3$. We start with `tryC` method.

1. STM `tryC`:

- (a) Line 3 : This line invokes `abort()` method on T_i which releases all the locks and returns \mathcal{A} to the invoking thread. Here T_i is aborted because its valid flag, is set to false by some other transaction, say T_j , in its `tryC` algorithm. This can occur in Lines: 45, 74 where T_i is added to T_j 's `abortRL` set. Later in Line 94, T_i 's valid flag is set to false. Note that T_i 's valid is true (after the execution of the last event) in $H1$. Thus, T_i 's valid flag must have been set to false in an extension of $H1$, which we again denote as $H2$.

This can happen only if in both the above cases, T_j is live in $H2$ and its ITS is less than T_i 's ITS. But we have that T_i 's `itsEnabled` in $H2$. As a result, it has the smallest among all live and aborted transactions of $H2$. Hence, there cannot exist such a T_j which is live and $H2.its_j < H2.its_i$. Thus, this case is not possible.

- (b) Line 15: This line is executed in $H2$ if there exists no version of x whose `ts` is less than T_i 's WTS. This implies that all the versions of x have `ts` greater than wts_i . Thus the transactions that created these versions have WTS greater than wts_i and have already committed in $H2$. Let T_j create one such version. Hence, we have that $\langle (T_j \in H2.committed) \implies (T_j \in H3.committed) \rangle$ since $H3$ is an extension of $H2$.
- (c) Line 34 : This case is similar to Case 1a, i.e., Line 3.
- (d) Line 47 : In this line, T_i is aborted as some other transaction T_j in T_i 's `largeRL` has committed. Any transaction in T_i 's `largeRL` has WTS greater than T_i 's WTS. This implies that T_j is already committed in $H2$ and hence committed in $H3$ as well.
- (e) Line 64 : In this line, T_i is aborted because its lower limit has crossed its upper limit. First, let us consider $tutl_i$. It is initialized in `tbegin` method to ∞ . As long as it is ∞ , these limits cannot cross each other. Later, $tutl_i$ is updated in Line 17 of `read` method, Line 58 & Line 62 of `tryC` method. Suppose $tutl_i$ gets decremented to some value α by one of these lines.
Now there are two cases here: (1) Suppose $tutl_i$ gets decremented to $comTime_i$ due to Line 62 of `tryC` method. Then from Lemma 34, we have $tll_i \leq comTime_i = tutl_i$. Thus in this case, T_i will not abort. (2) $tutl_i$ gets decremented to α which is less than $comTime_i$. Then from Lemma 35, we get that there is a committed transaction T_j in $H2.committed$ such that $wts_j > wts_i$. This implies that T_j is in $H3.committed$.
- (f) Line 76: This case is similar to Case 1a, i.e., Line 3.
- (g) Line 79 : In this case, T_k is in T_i 's `smallRL` and is committed in $H1$. And, from this case, we have that

$$H2.tutl_i \leq H2.tll_k \tag{5}$$

From the assumption of this case, we have that T_k commits before T_i . Thus, from Lemma 36, we get that $comTime_k < comTime_i$. From Lemma 34, we have that $tll_k \leq comTime_k$. Thus, we get that $tll_k < comTime_i$. Combining this with the inequality of this case Eqn(5), we get that $tutl_i < comTime_i$.

Combining this inequality with Lemma 35, we get that there is a transaction T_j in $H2.committed$ and $H2.wts_j > H2.wts_i$. This implies that T_j is in $H3.committed$ as well.

2. STM read:

- (a) Line 7: This case is similar to Case 1a, i.e., Line 3
- (b) Line 22: The reasoning here is similar to Case 1e, i.e., Line 64.

The interesting aspect of the above lemma is that it gives us a insight as to when a T_i will get commit. If an `itsEnabled` transaction T_i aborts then it is because of another transaction T_j with WTS higher than T_i has committed. To precisely capture this, we define two more notions of a transaction being enabled `cdsEnabled` and `finEnabled`. To define these notions of enabled, we in turn define a few other auxiliary notions. We start with `affectSet`,

$$H.affectSet(T_i) = \{T_j | (T_j \in H.txns) \wedge (H.its_j < H.its_i + 2 * L)\}$$

From the description of KSFTM algorithm and Lemma 31, it can be seen that a transaction T_i 's commit can depend on committing of transactions (or their incarnations) which have their ITS less than ITS of $T_i + 2*L$, which

is T_i 's *affectSet*. We capture this notion of dependency for a transaction T_i in a history H as *commit dependent set* or *cds* as: the set of all transactions T_j in T_i 's *affectSet* that do not any incarnation that is committed yet, i.e., not yet have their *incarCt* flag set as true. Formally,

$$H.cds(T_i) = \{T_j | (T_j \in H.affectSet(T_i)) \wedge (\neg H.incarCt(T_j))\}$$

Based on this definition of *cds*, we next define the notion of *cdsEnabled*.

Definition 2 We say that transaction T_i is *cdsEnabled* if the following conditions hold true (1) T_i is live in H ; (2) *CTS* of T_i is greater than or equal to *ITS* of $T_i + 2 * L$; (3) *cds* of T_i is empty, i.e., for all transactions T_j in H with *ITS* lower than *ITS* of $T_i + 2 * L$ in H have their *incarCt* to be true. Formally,

$$H.cdsEnabled(T_i) = \begin{cases} True & (T_i \in H.live) \wedge (H.cts_i \geq H.its_i + 2 * L) \wedge (H.cds(T_i) = \phi) \\ False & otherwise \end{cases}$$

The meaning and usefulness of these definitions will become clear in the course of the proof. In fact, we later show that once the transaction T_i is *cdsEnabled*, it will eventually commit. We will start with a few lemmas about these definitions.

Lemma 38 Consider a transaction T_i in a history H . If T_i is *cdsEnabled* then T_i is also *itsEnabled*. Formally, $\langle H, T_i : (T_i \in H.txns) \wedge (H.cdsEnabled(T_i)) \implies (H.itsEnabled(T_i)) \rangle$.

Proof. If T_i is *cdsEnabled* in H then it implies that T_i is live in H . From the definition of *cdsEnabled*, we get that $H.cds(T_i)$ is ϕ implying that any transaction T_j with *its_k* less than *its_i + 2 * L* has its *incarCt* flag as true in H . Hence, for any transaction T_k having *its_k* less than *its_i*, $H.incarCt(T_k)$ is also true. This shows that T_i is *itsEnabled* in H .

Lemma 39 Consider a transaction T_i which is *cdsEnabled* in a history $H1$. Consider an extension of $H1$, $H2$ with a transaction T_j in it such that T_i is an incarnation of T_j . Let T_k be a transaction in the *affectSet* of T_j in $H2$ Then T_k is also in the set of transaction of $H1$. Formally, $\langle H1, H2, T_i, T_j, T_k : (H1 \sqsubseteq H2) \wedge (H1.cdsEnabled(T_i)) \wedge (T_i \in H2.incarSet(T_j)) \wedge (T_k \in H2.affectSet(T_j)) \implies (T_k \in H1.txns) \rangle$

Proof. Since T_i is *cdsEnabled* in $H1$, we get (from the definition of *cdsEnabled*) that

$$H1.cts_i \geq H1.its_i + 2 * L \quad (6)$$

Here, we have that T_k is in $H2.affectSet(T_j)$. Thus from the definition of *affectSet*, we get that

$$H2.its_k < H2.its_j + 2 * L \quad (7)$$

Since T_i and T_j are incarnations of each other, their *ITS* are the same. Combining this with Eqn(7), we get that

$$H2.its_k < H1.its_i + 2 * L \quad (8)$$

We now show this proof through contradiction. Suppose T_k is not in $H1.txns$. Then there are two cases:

- No incarnation of T_k is in $H1$: This implies that T_k starts afresh after $H1$. Since T_k is not in $H1$, from Corollary 27 we get that

$$\begin{aligned} H2.cts_k > H1.sys-time &\xrightarrow[H2.cts_k=H2.its_k]{T_k \text{ starts afresh}} H2.its_k > H1.sys-time \xrightarrow[H1.sys-time \geq H1.cts_i]{(T_i \in H1) \wedge \text{Lemma 26}} H2.its_k > \\ H1.cts_i &\xrightarrow{Eqn(6)} H2.its_k > H1.its_i + 2 * L \xrightarrow[H1.its_i=H2.its_j]{H1.its_i=H2.its_j} H2.its_k > H2.its_j + 2 * L \end{aligned}$$

But this result contradicts with Eqn(7). Hence, this case is not possible.

- There is an incarnation of T_k, T_l in $H1$: In this case, we have that

$$H1.its_l = H2.its_k \quad (9)$$

Now combing this result with Eqn(8), we get that $H1.its_l < H1.its_i + 2 * L$. This implies that T_l is in affectSet of T_i in $H1$. Since T_i is cdsEnabled, we get that T_l 's incarCt must be true.

We also have that T_k is not in $H1$ but in $H2$ where $H2$ is an extension of $H1$. Since $H2$ has some events more than $H1$, we get that $H2$ is a strict extension of $H1$.

Thus, we have that, $(H1 \sqsubseteq H2) \wedge (H1.incarCt(T_l)) \wedge (T_k \in H2.txns) \wedge (T_k \notin H1.txns)$. Combining these with Lemma 19, we get that $(H1.its_l \neq H2.its_k)$. But this result contradicts Eqn(9). Hence, this case is also not possible.

Thus from both the cases we get that T_k should be in $H1$. Hence proved.

Lemma 40 Consider two histories $H1, H2$ where $H2$ is an extension of $H1$. Let T_i, T_j, T_k be three transactions such that T_i is in $H1.txns$ while T_j, T_k are in $H2.txns$. Suppose we have that (1) cts_i is greater than $its_i + 2 * L$ in $H1$; (2) T_i is an incarnation of T_j ; (3) T_k is in affectSet of T_j in $H2$. Then an incarnation of T_k , say T_l (which could be same as T_k) is in $H1.txns$. Formally, $\langle H1, H2, T_i, T_j, T_k : (H1 \sqsubseteq H2) \wedge (T_i \in H1.txns) \wedge (\{T_j, T_k\} \in H2.txns) \wedge (H1.cts_i > H1.its_i + 2 * L) \wedge (T_i \in H2.incarSet(T_j)) \wedge (T_k \in H2.affectSet(T_j)) \implies (\exists T_l : (T_l \in H2.incarSet(T_k)) \wedge (T_l \in H1.txns)) \rangle$

Proof.

This proof is similar to the proof of Lemma 39. We are given that

$$H1.cts_i \geq H1.its_i + 2 * L \quad (10)$$

We now show this proof through contradiction. Suppose no incarnation of T_k is in $H1.txns$. This implies that T_k must have started afresh in some history $H3$ which is an extension of $H1$. Also note that $H3$ could be same as $H2$ or a prefix of it, i.e., $H3 \sqsubseteq H2$. Thus, we have that

$$\begin{aligned} H3.its_k > H1.sys-time &\xrightarrow{\text{Lemma 26}} H3.its_k > H1.cts_i \xrightarrow{\text{Eqn(10)}} H3.its_k > H1.its_i + 2 * L \xrightarrow{H1.its_i = H2.its_j} \\ H3.its_k > H2.its_j + 2 * L &\xrightarrow[\text{Observation 21}]{H3 \sqsubseteq H2} H2.its_k > H2.its_j + 2 * L \xrightarrow[\text{definition}]{\text{affectSet}} T_k \notin H2.affectSet(T_j) \end{aligned}$$

But we are given that T_k is in affectSet of T_j in $H2$. Hence, it is not possible that T_k started afresh after $H1$. Thus, T_k must have an incarnation in $H1$.

Lemma 41 Consider a transaction T_i which is cdsEnabled in a history $H1$. Consider an extension of $H1, H2$ with a transaction T_j in it such that T_j is an incarnation of T_i in $H2$. Then affectSet of T_i in $H1$ is same as the affectSet of T_j in $H2$. Formally, $\langle H1, H2, T_i, T_j : (H1 \sqsubseteq H2) \wedge (H1.cdsEnabled(T_i)) \wedge (T_j \in H2.txns) \wedge (T_i \in H2.incarSet(T_j)) \implies ((H1.affectSet(T_i) = H2.affectSet(T_j))) \rangle$

Proof. From the definition of cdsEnabled, we get that T_i is in $H1.txns$. Now to prove that affectSets are the same, we have to show that $(H1.affectSet(T_i) \subseteq H2.affectSet(T_j))$ and $(H2.affectSet(T_j) \subseteq H1.affectSet(T_i))$. We show them one by one:

$(H1.affectSet(T_i) \subseteq H2.affectSet(T_j))$: Consider a transaction T_k in $H1.affectSet(T_i)$. We have to show that T_k is also in $H2.affectSet(T_j)$. From the definition of affectSet, we get that

$$T_k \in H1.txns \quad (11)$$

Combining Eqn(11) with Observation 21, we get that

$$T_k \in H2.txns \quad (12)$$

From the definition of ITS, we get that

$$H1.its_k = H2.its_k \quad (13)$$

Since T_i, T_j are incarnations we have that .

$$H1.its_i = H2.its_j \quad (14)$$

From the definition of affectSet, we get that,

$$H1.its_k < H1.its_i + 2 * L \xrightarrow{\text{Eqn(13)}} H2.its_k < H1.its_i + 2 * L \xrightarrow{\text{Eqn(14)}} H2.its_k < H2.its_j + 2 * L$$

Combining this result with Eqn(12), we get that $T_k \in H2.affectSet(T_j)$.

$(H1.affectSet(T_i) \subseteq H2.affectSet(T_j))$: Consider a transaction T_k in $H2.affectSet(T_j)$. We have to show that T_k is also in $H1.affectSet(T_i)$. From the definition of $affectSet$, we get that $T_k \in H2.txns$.

Here, we have that $(H1 \sqsubseteq H2) \wedge (H1.cdsEnabled(T_i)) \wedge (T_i \in H2.incarSet(T_j)) \wedge (T_k \in H2.affectSet(T_j))$. Thus from Lemma 39, we get that $T_k \in H1.txns$. Now, this case is similar to the above case. It can be seen that Equations 11, 12, 13, 14 hold good in this case as well.

Since T_k is in $H2.affectSet(T_j)$, we get that

$$H2.its_k < H2.its_i + 2 * L \xrightarrow{Eqn(13)} H1.its_k < H2.its_j + 2 * L \xrightarrow{Eqn(14)} H1.its_k < H1.its_i + 2 * L$$

Combining this result with Eqn(11), we get that $T_k \in H1.affectSet(T_i)$.

Next we explore how a $cdsEnabled$ transaction remains $cdsEnabled$ in the future histories once it becomes true.

Lemma 42 Consider two histories $H1$ and $H2$ with $H2$ being an extension of $H1$. Let T_i and T_j be two transactions which are live in $H1$ and $H2$ respectively. Let T_i be an incarnation of T_j and cts_i is less than cts_j . Suppose T_i is $cdsEnabled$ in $H1$. Then T_j is $cdsEnabled$ in $H2$ as well. Formally, $\langle H1, H2, T_i, T_j : (H1 \sqsubseteq H2) \wedge (T_i \in H1.live) \wedge (T_j \in H2.live) \wedge (T_i \in H2.incarSet(T_j)) \wedge (H1.cts_i < H2.cts_j) \wedge (H1.cdsEnabled(T_i)) \implies (H2.cdsEnabled(T_j)) \rangle$.

Proof. We have that T_i is live in $H1$ and T_j is live in $H2$. Since T_i is $cdsEnabled$ in $H1$, we get (from the definition of $cdsEnabled$) that

$$H1.cts_i \geq H2.its_i + 2 * L \tag{15}$$

We are given that cts_i is less than cts_j and T_i, T_j are incarnations of each other. Hence, we have that

$$\begin{aligned} H2.cts_j &> H1.cts_i \\ &> H1.its_i + 2 * L && \text{[From Eqn(15)]} \\ &> H2.its_j + 2 * L && [its_i = its_j] \end{aligned}$$

Thus we get that $cts_j > its_j + 2 * L$. We have that T_j is live in $H2$. In order to show that T_j is $cdsEnabled$ in $H2$, it only remains to show that cds of T_j in $H2$ is empty, i.e., $H2.cds(T_j) = \phi$. The cds becomes empty when all the transactions of T_j 's $affectSet$ in $H2$ have their $incarCt$ as true in $H2$.

Since T_j is live in $H2$, we get that T_j is in $H2.txns$. Here, we have that $(H1 \sqsubseteq H2) \wedge (T_j \in H2.txns) \wedge (T_i \in H2.incarSet(T_j)) \wedge (H1.cdsEnabled(T_i))$. Combining this with Lemma 41, we get that $H1.affectSet(T_i) = H2.affectSet(T_j)$.

Now, consider a transaction T_k in $H2.affectSet(T_j)$. From the above result, we get that T_k is also in $H1.affectSet(T_i)$. Since T_i is $cdsEnabled$ in $H1$, i.e., $H1.cdsEnabled(T_i)$ is true, we get that $H1.incarCt(T_k)$ is true. Combining this with Observation 18, we get that T_k must have its $incarCt$ as true in $H2$ as well, i.e. $H2.incarCt(T_k)$. This implies that all the transactions in T_j 's $affectSet$ have their $incarCt$ flags as true in $H2$. Hence the $H2.cds(T_j)$ is empty. As a result, T_j is $cdsEnabled$ in $H2$, i.e., $H2.cdsEnabled(T_j)$.

Having defined the properties related to $cdsEnabled$, we start defining notions for $finEnabled$. Next, we define $maxWTS$ for a transaction T_i in H which is the transaction T_j with the largest WTS in T_i 's $incarSet$. Formally,

$$H.maxWTS(T_i) = \max\{H.wts_j | (T_j \in H.incarSet(T_i))\}$$

From this definition of $maxWTS$, we get the following simple observation.

Observation 43 For any transaction T_i in H , we have that wts_i is less than or equal to $H.maxWTS(T_i)$. Formally, $H.wts_i \leq H.maxWTS(T_i)$.

Next, we combine the notions of $affectSet$ and $maxWTS$ to define $affWTS$. It is the maximum of $maxWTS$ of all the transactions in its $affectSet$. Formally,

$$H.affWTS(T_i) = \max\{H.maxWTS(T_j) | (T_j \in H.affectSet(T_i))\}$$

Having defined the notion of $affWTS$, we get the following lemma relating the $affectSet$ and $affWTS$ of two transactions.

Lemma 44 Consider two histories $H1$ and $H2$ with $H2$ being an extension of $H1$. Let T_i and T_j be two transactions which are live in $H1$ and $H2$ respectively. Suppose the *affectSet* of T_i in $H1$ is same as *affectSet* of T_j in $H2$. Then the *affWTS* of T_i in $H1$ is same as *affWTS* of T_j in $H2$. Formally, $\langle H1, H2, T_i, T_j : (H1 \sqsubseteq H2) \wedge (T_i \in H1.txns) \wedge (T_j \in H2.txns) \wedge (H1.affectSet(T_i) = H2.affectSet(T_j)) \implies (H1.affWTS(T_i) = H2.affWTS(T_j)) \rangle$.

Proof.

From the definition of *affWTS*, we get the following equations

$$H.affWTS(T_i) = \max\{H.maxWTS(T_k) \mid (T_k \in H1.affectSet(T_i))\} \quad (16)$$

$$H.affWTS(T_j) = \max\{H.maxWTS(T_l) \mid (T_l \in H2.affectSet(T_j))\} \quad (17)$$

From these definitions, let us suppose that $H1.affWTS(T_i)$ is $H1.maxWTS(T_p)$ for some transaction T_p in $H1.affectSet(T_i)$. Similarly, suppose that $H2.affWTS(T_j)$ is $H2.maxWTS(T_q)$ for some transaction T_q in $H2.affectSet(T_j)$.

Here, we are given that $H1.affectSet(T_i) = H2.affectSet(T_j)$. Hence, we get that T_p is also in $H1.affectSet(T_i)$. Similarly, T_q is in $H2.affectSet(T_j)$ as well. Thus from Equations (16) & (17), we get that

$$H1.maxWTS(T_p) \geq H2.maxWTS(T_q) \quad (18)$$

$$H2.maxWTS(T_q) \geq H1.maxWTS(T_p) \quad (19)$$

Combining these both equations, we get that $H1.maxWTS(T_p) = H2.maxWTS(T_q)$ which in turn implies that $H1.affWTS(T_i) = H2.affWTS(T_j)$.

Finally, using the notion of *affWTS* and *cdsEnabled*, we define the notion of *finEnabled*

Definition 3 We say that transaction T_i is *finEnabled* if the following conditions hold true (1) T_i is live in H ; (2) T_i is *cdsEnabled* in H ; (3) $H.wts_j$ is greater than $H.affWTS(T_i)$. Formally,

$$H.finEnabled(T_i) = \begin{cases} True & (T_i \in H.live) \wedge (H.cdsEnabled(T_i)) \wedge (H.wts_j > H.affWTS(T_i)) \\ False & otherwise \end{cases}$$

It can be seen from this definition, a transaction that is *finEnabled* is also *cdsEnabled*. We now show that just like *itsEnabled* and *cdsEnabled*, once a transaction is *finEnabled*, it remains *finEnabled* until it terminates. The following lemma captures it.

Lemma 45 Consider two histories $H1$ and $H2$ with $H2$ being an extension of $H1$. Let T_i and T_j be two transactions which are live in $H1$ and $H2$ respectively. Suppose T_i is *finEnabled* in $H1$. Let T_i be an incarnation of T_j and cts_i is less than cts_j . Then T_j is *finEnabled* in $H2$ as well. Formally, $\langle H1, H2, T_i, T_j : (H1 \sqsubseteq H2) \wedge (T_i \in H1.live) \wedge (T_j \in H2.live) \wedge (T_i \in H2.incarSet(T_j)) \wedge (H1.cts_i < H2.cts_j) \wedge (H1.finEnabled(T_i)) \implies (H2.finEnabled(T_j)) \rangle$.

Proof. Here we are given that T_j is live in $H2$. Since T_i is *finEnabled* in $H1$, we get that it is *cdsEnabled* in $H1$ as well. Combining this with the conditions given in the lemma statement, we have that,

$$\langle (H1 \sqsubseteq H2) \wedge (T_i \in H1.live) \wedge (T_j \in H2.live) \wedge (T_i \in H2.incarSet(T_j)) \wedge (H1.cts_i < H2.cts_j) \wedge (H1.cdsEnabled(T_i)) \rangle \quad (20)$$

Combining Eqn(20) with Lemma 42, we get that T_j is *cdsEnabled* in $H2$, i.e., $H2.cdsEnabled(T_j)$. Now, in order to show that T_j is *finEnabled* in $H2$ it remains for us to show that $H2.wts_j > H2.affWTS(T_j)$.

We are given that T_j is live in $H2$ which in turn implies that T_j is in $H2.txns$. Thus changing this in Eqn(20), we get the following

$$\langle (H1 \sqsubseteq H2) \wedge (T_j \in H2.txns) \wedge (T_i \in H2.incarSet(T_j)) \wedge (H1.cts_i < H2.cts_j) \wedge (H1.cdsEnabled(T_i)) \rangle \quad (21)$$

Combining Eqn(21) with Lemma 41 we get that

$$H1.affWTS(T_i) = H2.affWTS(T_j) \quad (22)$$

We are given that $H1.cts_i < H2.cts_j$. Combining this with the definition of WTS, we get

$$H1.wts_i < H2.wts_j \quad (23)$$

Since T_i is finEnabled in $H1$, we have that

$$H1.wts_i > H1.affWTS(T_i) \xrightarrow{Eqn(23)} H2.wts_j > H1.affWTS(T_i) \xrightarrow{Eqn(22)} H2.wts_j > H2.affWTS(T_j)$$

Now, we show that a transaction that is finEnabled will eventually commit.

Lemma 46 Consider a live transaction T_i in a history $H1$. Suppose T_i is finEnabled in $H1$ and $valid_i$ is true in $H1$. Then there exists an extension of $H1$, $H3$ in which T_i is committed. Formally, $\langle H1, T_i : (T_i \in H1.live) \wedge (H1.valid_i) \wedge (H1.finEnabled(T_i)) \implies (\exists H3 : (H1 \sqsubseteq H3) \wedge (T_i \in H3.committed)) \rangle$.

Proof. Consider a history $H3$ such that its sys-time being greater than $cts_i + L$. We will prove this lemma using contradiction. Suppose T_i is aborted in $H3$.

Now consider T_i in $H1$: T_i is live; its valid flag is true; and is finEnabled. From the definition of finEnabled, we get that it is also cdsEnabled. From Lemma 38, we get that T_i is itsEnabled in $H1$. Thus from Lemma 37, we get that there exists an extension of $H1$, $H2$ such that (1) Transaction T_i is live in $H2$; (2) there is a transaction T_j in $H2$; (3) $H2.wts_j$ is greater than $H2.wts_i$; (4) T_j is committed in $H3$. Formally,

$$\langle (\exists H2, T_j : (H1 \sqsubseteq H2 \sqsubseteq H3) \wedge (T_i \in H2.live) \wedge (T_j \in H2.txns) \wedge (H2.wts_i < H2.wts_j) \wedge (T_j \in H3.committed)) \rangle \quad (24)$$

Here, we have that $H2$ is an extension of $H1$ with T_i being live in both of them and T_i is finEnabled in $H1$. Thus from Lemma 45, we get that T_i is finEnabled in $H2$ as well. Now, let us consider T_j in $H2$. From Eqn(24), we get that $(H2.wts_i < H2.wts_j)$. Combining this with the observation that T_i being live in $H2$, Lemma 31 we get that $(H2.its_j \leq H2.its_i + 2 * L)$.

This implies that T_j is in affectSet of T_i in $H2$, i.e., $(T_j \in H2.affectSet(T_i))$. From the definition of affWTS, we get that

$$(H2.affWTS(T_i) \geq H2.maxWTS(T_j)) \quad (25)$$

Since T_i is finEnabled in $H2$, we get that wts_i is greater than affWTS of T_i in $H2$.

$$(H2.wts_i > H2.affWTS(T_i)) \quad (26)$$

Now combining Equations 25, 26 we get,

$$\begin{aligned} H2.wts_i &> H2.affWTS(T_i) \geq H2.maxWTS(T_j) \\ &> H2.affWTS(T_i) \geq H2.maxWTS(T_j) \geq H2.wts_j \quad [\text{From Observation 43}] \\ &> H2.wts_j \end{aligned}$$

But this equation contradicts with Eqn(24). Hence our assumption that T_i will get aborted in $H3$ after getting finEnabled is not possible. Thus T_i has to commit in $H3$.

Next we show that once a transaction T_i becomes itsEnabled, it will eventually become finEnabled as well and then committed. We show this change happens in a sequence of steps. We first show that Transaction T_i which is itsEnabled first becomes cdsEnabled (or gets committed). We next show that T_i which is cdsEnabled becomes finEnabled or get committed. On becoming finEnabled, we have already shown that T_i will eventually commit.

Now, we show that a transaction that is itsEnabled will become cdsEnabled or committed. To show this, we introduce a few more notations and definitions. We start with the notion of *depIts* (*dependent-its*) which is the set of ITSs that a transaction T_i depends on to commit. It is the set of ITS of all the transactions in T_i 's cds in a history H . Formally,

$$H.depIts(T_i) = \{H.its_j | T_j \in H.cds(T_i)\}$$

We have the following lemma on the depIts of a transaction T_i and its future incarnation T_j which states that depIts of a T_i either reduces or remains the same.

Lemma 47 Consider two histories $H1$ and $H2$ with $H2$ being an extension of $H1$. Let T_i and T_j be two transactions which are live in $H1$ and $H2$ respectively and T_i is an incarnation of T_j . In addition, we also have that cts_i is greater than $its_i + 2 * L$ in $H1$. Then, we get that $H2.depIts(T_j)$ is a subset of $H1.depIts(T_i)$. Formally, $\langle H1, H2, T_i, T_j : (H1 \sqsubseteq H2) \wedge (T_i \in H1.live) \wedge (T_j \in H2.live) \wedge (T_i \in H2.incarSet(T_j)) \wedge (H1.cts_i \geq H1.its_i + 2 * L) \implies (H2.depIts(T_j) \subseteq H1.depIts(T_i)) \rangle$.

Proof. Suppose $H2.depIts(T_j)$ is not a subset of $H1.depIts(T_i)$. This implies that there is a transaction T_k such that $H2.its_k \in H2.depIts(T_j)$ but $H1.its_k \notin H1.depIts(T_j)$. This implies that T_k starts afresh after $H1$ in some history say $H3$ such that $H1 \sqsubset H3 \sqsubseteq H2$. Hence, from Corollary 27 we get the following

$$H3.its_k > H1.sys-time \xrightarrow{\text{Lemma 26}} H3.its_k > H1.cts_i \implies H3.its_k > H1.its_i + 2 * L \xrightarrow{H1.its_i = H2.its_j} H3.its_k > H2.its_j + 2 * L \xrightarrow[\text{definitions}]{\text{affectSet, depIts}} H2.its_k \notin H2.depIts(T_j)$$

We started with its_k in $H2.depIts(T_j)$ and ended with its_k not in $H2.depIts(T_j)$. Thus, we have a contradiction. Hence, the lemma follows.

Next we denote the set of committed transactions in T_i 's affectSet in H as *cis* (commit independent set). Formally,

$$H.cis(T_i) = \{T_j | (T_j \in H.affectSet(T_i)) \wedge (H.incarCt(T_j))\}$$

In other words, we have that $H.cis(T_i) = H.affectSet(T_i) - H.cds(T_i)$. Finally, using the notion of *cis* we denote the maximum of maxWTS of all the transactions in T_i 's *cis* as *partAffWTS* (partly affecting WTS). It turns out that the value of *partAffWTS* affects the commit of T_i which we show in the course of the proof. Formally, *partAffWTS* is defined as

$$H.partAffWTS(T_i) = \max\{H.maxWTS(T_j) | (T_j \in H.cis(T_i))\}$$

Having defined the required notations, we are now ready to show that a *itsEnabled* transaction will eventually become *cdsEnabled*.

Lemma 48 Consider a transaction T_i which is live in a history $H1$ and cts_i is greater than or equal to $its_i + 2 * L$. If T_i is *itsEnabled* in $H1$ then there is an extension of $H1$, $H2$ in which an incarnation T_i, T_j (which could be same as T_i), is either committed or *cdsEnabled*. Formally, $\langle H1, T_i : (T_i \in H1.live) \wedge (H1.cts_i \geq H1.its_i + 2 * L) \wedge (H1.itsEnabled(T_i)) \implies (\exists H2, T_j : (H1 \sqsubset H2) \wedge (T_j \in H2.incarSet(T_i)) \wedge ((T_j \in H2.committed) \vee (H2.cdsEnabled(T_j)))) \rangle$.

Proof. We prove this by inducting on the size of $H1.depIts(T_i)$, n . For showing this, we define a boolean function $P(k)$ as follows:

$$P(k) = \begin{cases} True & \langle H1, T_i : (T_i \in H1.live) \wedge (H1.cts_i \geq H1.its_i + 2 * L) \wedge (H1.itsEnabled(T_i)) \wedge \\ & (k \geq |H1.depIts(T_i)|) \implies (\exists H2, T_j : (H1 \sqsubset H2) \wedge (T_j \in H2.incarSet(T_i)) \wedge \\ & ((T_j \in H2.committed) \vee (H2.cdsEnabled(T_j)))) \rangle \\ False & \text{otherwise} \end{cases}$$

As can be seen, here $P(k)$ means that if (1) T_i is live in $H1$; (2) cts_i is greater than or equal to $its_i + 2 * L$; (3) T_i is *itsEnabled* in $H1$ (4) the size of $H1.depIts(T_i)$ is less than or equal to k ; then there exists a history $H2$ with a transaction T_j in it which is an incarnation of T_i such that T_j is either committed or *cdsEnabled* in $H2$. We show $P(k)$ is true for all (integer) values of k using induction.

Base Case - $P(0)$: Here, from the definition of $P(0)$, we get that $|H1.depIts(T_i)| = 0$. This in turn implies that $H1.cds(T_i)$ is null. Further, we are already given that T_i is live in $H1$ and $H1.cts_i \geq H1.its_i + 2 * L$. Hence, all these imply that T_i is *cdsEnabled* in $H1$.

Induction case - To prove $P(k + 1)$ given that $P(k)$ is true: If $|H1.depIts(T_i)| \leq k$, from the induction hypothesis $P(k)$, we get that T_j is either committed or *cdsEnabled* in $H2$. Hence, we consider the case when

$$|H1.depIts(T_i)| = k + 1 \tag{27}$$

Let α be $H1.partAffWTS(T_i)$. Suppose $H1.wts_i < \alpha$. Then from Lemma 25, we get that there is an extension of $H1$, say $H3$ in which an incarnation of T_i, T_l (which could be same as T_i) is committed or is live in $H3$ and has WTS greater than α . If T_l is committed then $P(k + 1)$ is trivially true. So we consider the latter case in which T_l is live in $H3$. In case $H1.wts_i \geq \alpha$, then in the analysis below follow where we can replace T_l with T_i .

Next, suppose T_l is aborted in an extension of $H3, H5$. Then from Lemma 37, we get that there exists an extension of $H3, H4$ in which (1) T_l is live; (2) there is a transaction T_m in $H4.txns$; (3) $H4.wts_m > H4.wts_l$ (4) T_m is committed in $H5$.

Combining the above derived conditions (1), (2), (3) with Lemma 34 we get that in $H4$,

$$H4.its_m \leq H4.its_l + 2 * L \quad (28)$$

Eqn(28) implies that T_m is in T_l 's affectSet. Here, we have that T_l is an incarnation of T_i and we are given that $H1.cts_i \geq H1.its_i + 2 * L$. Thus from Lemma 40, we get that there exists an incarnation of T_m, T_n in $H1$.

Combining Eqn(28) with the observations (a) T_n, T_m are incarnations; (b) T_l, T_i are incarnations; (c) T_i, T_n are in $H1.txns$, we get that $H1.its_n \leq H1.its_i + 2 * L$. This implies that T_n is in $H1.affectSet(T_i)$. Since T_n is not committed in $H1$ (otherwise, it is not possible for T_m to be an incarnation of T_n), we get that T_n is in $H1.cds(T_i)$. Hence, we get that $H4.its_m = H1.its_n$ is in $H1.depIts(T_i)$.

From Eqn(27), we have that $H1.depIts(T_i)$ is $k+1$. From Lemma 47, we get that $H4.depIts(T_i)$ is a subset of $H1.depIts(T_i)$. Further, we have that transaction T_m has committed. Thus $H4.its_m$ which was in $H1.depIts(T_i)$ is no longer in $H4.depIts(T_i)$. This implies that $H4.depIts(T_i)$ is a strict subset of $H1.depIts(T_i)$ and hence $|H4.depIts(T_i)| \leq k$.

Since T_i and T_l are incarnations, we get that $H4.depIts(T_i) = H1.depIts(T_l)$. Thus, we get that

$$|H4.depIts(T_i)| \leq k \implies |H4.depIts(T_l)| \leq k \quad (29)$$

Further, we have that T_l is a later incarnation of T_i . So, we get that

$$H4.cts_l > H4.cts_i \xrightarrow{\text{given}} H4.cts_l > H4.its_i + 2 * L \xrightarrow{H4.its_i = H4.its_l} H4.cts_l > H4.its_l + 2 * L \quad (30)$$

We also have that T_l is live in $H4$. Combining this with Equations 29, 30 and given the induction hypothesis that $P(k)$ is true, we get that there exists a history extension of $H4, H6$ in which an incarnation of T_l (also T_i), T_p is either committed or cdsEnabled. This proves the lemma.

Lemma 49 Consider a transaction T_i in a history $H1$. If T_i is cdsEnabled in $H1$ then there is an extension of $H1, H2$ in which an incarnation T_i, T_j (which could be same as T_i), is either committed or finEnabled. Formally, $\langle H1, T_i : (T_i \in H1.live) \wedge (H1.cdsEnabled(T_i)) \implies (\exists H2, T_j : (H1 \sqsubset H2) \wedge (T_j \in H2.incarSet(T_i)) \wedge ((T_j \in H2.committed) \vee (H2.finEnabled(T_j)))) \rangle$.

Proof. In $H1$, suppose $H1.afWTS(T_i)$ is α . From Lemma 25, we get that there is a extension of $H1, H2$ with a transaction T_j which is an incarnation of T_i . Here there are two cases: (1) Either T_j is committed in $H2$. This trivially proves the lemma; (2) Otherwise, wts_j is greater than α .

In the second case, we get that

$$(T_i \in H1.live) \wedge (T_j \in H2.live) \wedge (H1.cdsEnabled(T_i)) \wedge (T_j \in H2.incarSet(T_i)) \wedge (H1.wts_i < H2.wts_j) \quad (31)$$

Combining the above result with Lemma 24, we get that $H1.cts_i < H2.cts_j$. Thus the modified equation is

$$(T_i \in H1.live) \wedge (T_j \in H2.live) \wedge (H1.cdsEnabled(T_i)) \wedge (T_j \in H2.incarSet(T_i)) \wedge (H1.cts_i < H2.cts_j) \quad (32)$$

Next combining Eqn(32) with Lemma 41, we get that

$$H1.affectSet(T_i) = H2.affectSet(T_j) \quad (33)$$

Similarly, combining Eqn(32) with Lemma 42 we get that T_j is cdsEnabled in $H2$ as well. Formally,

$$H2.cdsEnabled(T_j) \quad (34)$$

Now combining Eqn(33) with Lemma 44, we get that

$$H1.afWTS(T_i) = H2.afWTS(T_j) \quad (35)$$

From our initial assumption we have that $H1.af fWTS(T_i)$ is α . From Eqn(35), we get that $H2.af fWTS(T_j) = \alpha$. Further, we had earlier also seen that $H2.wts_j$ is greater than α . Hence, we have that $H2.wts_j > H2.af fWTS(T_j)$. Combining the above result with Eqn(34), $H2.cdsEnabled(T_j)$, we get that T_j is *finEnabled*, i.e., $H2.finEnabled(T_j)$.

Next, we show that every live transaction eventually become *itsEnabled*.

Lemma 50 *Consider a history $H1$ with T_i be a transaction in $H1.live$. Then there is an extension of $H1$, $H2$ in which an incarnation of T_i , T_j (which could be same as T_i) is either committed or is *itsEnabled*. Formally, $\langle H1, T_i : (T_i \in H1.live) \implies (\exists T_j, H2 : (H1 \sqsubset H2) \wedge (T_j \in H2.incarSet(T_i)) \wedge (T_j \in H2.committed) \vee (H2.itsEnabled(T_j))) \rangle$.*

Proof. We prove this lemma by inducting on ITS.

Base Case - $its_i = 1$: In this case, T_i is the first transaction to be created. There are no transactions with smaller ITS. Thus T_i is trivially *itsEnabled*.

Induction Case: Here we assume that for any transaction $its_i \leq k$ the lemma is true.

Combining these lemmas gives us the result that for every live transaction T_i there is an incarnation T_j (which could be the same as T_i) that will commit. This implies that every application-transaction eventually commits. The follow lemma captures this notion.

Theorem 51 *Consider a history $H1$ with T_i be a transaction in $H1.live$. Then there is an extension of $H1$, $H2$ in which an incarnation of T_i , T_j is committed. Formally, $\langle H1, T_i : (T_i \in H1.live) \implies (\exists T_j, H2 : (H1 \sqsubset H2) \wedge (T_j \in H2.incarSet(T_i)) \wedge (T_j \in H2.committed)) \rangle$.*

Proof. Here we show the states that a transaction T_i (or one of it its incarnations) undergoes before it commits. In all these transitions, it is possible that an incarnation of T_i can commit. But to show the worst case, we assume that no incarnation of T_i commits. Continuing with this argument, we show that finally an incarnation of T_i commits.

Consider a live transaction T_i in $H1$. Then from Lemma 50, we get that there is a history $H2$, which is an extension of $H1$, in which T_j an incarnation of T_i is either committed or *itsEnabled*. If T_j is *itsEnabled* in $H2$, then from Lemma 48, we get that T_k , an incarnation of T_j , will be *cdsEnabled* in a extension of $H2$, $H3$ (assuming that T_k is not committed in $H3$).

From Lemma 49, we get that there is an extension of $H3$, $H4$ in which an incarnation of T_k , T_l will be *finEnabled* assuming that it is not committed in $H4$. Finally, from Lemma 46, we get that there is an extension of $H4$ in which T_m , an incarnation of T_l , will be committed. This proves our theorem.

7 Discussion and Conclusion

Software Transactional Memory systems (*STMs*) have garnered significant interest as an elegant alternative for addressing synchronization and concurrency issues in multi-core systems. To be efficient, *STMs* must guarantee some progress properties. In this paper, we explore the problem of achieving starvation-freedom with *MVSTMs*.

We have proposed a K version starvation-free *MVSTM* system, *KSFTM*. The algorithm ensures that if an aborted transaction is retried successively, then it will eventually commit. The algorithm maintains K versions where K can range from between one to ∞ . When K is one, then this algorithm boils down to a single-version *STM* system. If K is ∞ , then it is similar to existing *MVSTMs* which do not maintain an upper bound on the number of versions. In this case, a separate garbage-collection thread will be required. When K is finite, then no separate garbage-collection thread will be required to remove the older versions. For correctness, we show *KSFTM* satisfies strict-serializable [21] & local opacity [17, 18]. To the best of our knowledge, this is the first work to explore starvation-freedom with *MVSTMs*.

We have also implemented *KSFTM* and compared its performance with a single version starvation free *STM* system (*SV-SFTM*) which works on the priority principle. Our experiments show that *KSFTM* achieves a speed-up of two-fold for workloads with 50% update & 50% read operations over *SV-SFTM*.

In this document, we have not considered a transactional solution based on two-phase locking (2PL) & its multi-version variants [27]. With the carefully designed 2PL solution, one can ensure that none of the transactions abort [27]. But this will require advance knowledge of the code of the transactions which may not always be available with the *STM* library. Without such knowledge, it is possible that a 2PL solution can deadlock & cause further aborts. Once we have aborts, once again faces the issue of starvation-freedom.

Since we have considered strict-serializable as one of the correctness-criteria, this algorithm can be extended to Databases as well. In fact, to the best of our knowledge, there has been no prior work on starvation-freedom in the context of Database concurrency control.

References

- [1] Utku Aydonat and Tarek S. Abdelrahman. Relaxed Concurrency Control in Software Transactional Memory. *IEEE Trans. Parallel Distrib. Syst.*, 23(7):1312–1325, July 2012.
- [2] Philip A. Bernstein and Nathan Goodman. Multiversion Concurrency Control: Theory and Algorithms. *ACM Trans. Database Syst.*, 8(4):465–483, December 1983.
- [3] Victor Bushkov, Rachid Guerraoui, and Michal Kapalka. On the liveness of transactional memory. In *ACM Symposium on Principles of Distributed Computing, PODC '12, Funchal, Madeira, Portugal, July 16-18, 2012*, pages 9–18, 2012.
- [4] Ved Prakash Chaudhary, Sandeep Kulkarni, Sweta Kumari, and Sathya Peri. Starvation freedom in multi-version transactional memory systems. *CoRR*, abs/1709.01033, 2017.
- [5] Tyler Crain, Damien Imbs, and Michel Raynal. Read invisibility, virtual world consistency and probabilistic permissiveness are compatible. In *ICA3PP (1)*, pages 244–257, 2011.
- [6] Sérgio Miguel Fernandes and Joao Cachopo. Lock-free and Scalable Multi-version Software Transactional Memory. In *Proceedings of the 16th ACM symposium on Principles and practice of parallel programming, PPOPP '11*, pages 179–188, New York, NY, USA, 2011. ACM.
- [7] Vincent Gramoli, Rachid Guerraoui, and Vasileios Trigonakis. TM2C: A Software Transactional Memory for Many-cores. In *Proceedings of the 7th ACM European Conference on Computer Systems, EuroSys '12*, pages 351–364, New York, NY, USA, 2012. ACM.
- [8] Rachid Guerraoui, Thomas Henzinger, and Vasu Singh. Permissiveness in Transactional Memories. In *DISC '08: Proc. 22nd International Symposium on Distributed Computing*, pages 305–319, sep 2008. Springer-Verlag Lecture Notes in Computer Science volume 5218.
- [9] Rachid Guerraoui and Michal Kapalka. On the Correctness of Transactional Memory. In *PPoPP*, pages 175–184, New York, NY, USA, 2008. ACM.
- [10] Rachid Guerraoui and Michal Kapalka. *Principles of Transactional Memory, Synthesis Lectures on Distributed Computing Theory*. Morgan and Claypool, 2010.
- [11] Maurice Herlihy. Wait-free Synchronization. *ACM Trans. Program. Lang. Syst.*, 13(1):124–149, January 1991.
- [12] Maurice Herlihy and J. Eliot B.Moss. Transactional memory: Architectural Support for Lock-Free Data Structures. *SIGARCH Comput. Archit. News*, 21(2):289–300, 1993.
- [13] Maurice Herlihy and Nir Shavit. On the nature of progress. In *Proceedings of the 15th International Conference on Principles of Distributed Systems, OPODIS'11*, pages 313–328, Berlin, Heidelberg, 2011. Springer-Verlag.
- [14] Maurice Herlihy and Nir Shavit. *The Art of Multiprocessor Programming, Revised Reprint*. Morgan Kaufmann Publishers Inc., San Francisco, CA, USA, 1st edition, 2012.
- [15] Damien Imbs, José Ramon de Mendivil, and Michel Raynal. Brief announcement: virtual world consistency: a new condition for STM systems. In *PODC*, pages 280–281, New York, NY, USA, 2009. ACM.
- [16] Priyanka Kumar, Sathya Peri, and K. Vidyasankar. A TimeStamp Based Multi-version STM Algorithm. In *ICDCN*, pages 212–226, 2014.
- [17] Petr Kuznetsov and Sathya Peri. Non-interference and Local Correctness in Transactional Memory. In *ICDCN*, pages 197–211, 2014.

- [18] Petr Kuznetsov and Sathya Peri. Non-interference and local correctness in transactional memory. *Theor. Comput. Sci.*, 688:103–116, 2017.
- [19] Petr Kuznetsov and Srivatsan Ravi. On the cost of concurrency in transactional memory. In *OPODIS*, pages 112–127, 2011.
- [20] Li Lu and Michael L. Scott. Generic multiversion STM. In *Distributed Computing - 27th International Symposium, DISC 2013, Jerusalem, Israel, October 14-18, 2013. Proceedings*, pages 134–148, 2013.
- [21] Christos H. Papadimitriou. The serializability of concurrent database updates. *J. ACM*, 26(4):631–653, 1979.
- [22] Dmitri Perelman, Anton Byshevsky, Oleg Litmanovich, and Idit Keidar. SMV: Selective Multi-Versioning STM. In *DISC*, pages 125–140, 2011.
- [23] Torvald Riegel, Pascal Felber, and Christof Fetzer. A lazy snapshot algorithm with eager validation. In *DISC*, pages 284–298, 2006.
- [24] Nir Shavit and Dan Touitou. Software Transactional Memory. In *PODC*, pages 204–213, New York, NY, USA, 1995. ACM.
- [25] Michael F. Spear, Luke Dalessandro, Virendra J. Marathe, and Michael L. Scott. A comprehensive strategy for contention management in software transactional memory, 2009.
- [26] M. M. Waliullah and Per Stenström. Schemes for Avoiding Starvation in Transactional Memory Systems. *Concurrency and Computation: Practice and Experience*, 21(7):859–873, 2009.
- [27] Gerhard Weikum and Gottfried Vossen. *Transactional Information Systems: Theory, Algorithms, and the Practice of Concurrency Control and Recovery*. Morgan Kaufmann, 2002.