

Deterministic Memory Abstraction and Supporting Multicore System Architecture

Farzad Farshchi[†], Prathap Kumar Valsan^{*}, Renato Mancuso[‡], Heechul Yun[†]

[†] University of Kansas, {farshchi, heechul.yun}@ku.edu

^{*} Intel, prathap.kumar.valsan@intel.com

[‡] Boston University, rmancuso@bu.edu

March 9, 2022

Abstract

Poor timing predictability of multicore processors has been a long-standing challenge in the real-time systems community. In this paper, we make a case that a fundamental problem that prevents efficient and predictable real-time computing on multicore is the *lack of a proper memory abstraction* to express memory criticality, which cuts across various layers of the system: the application, OS, and hardware. We, therefore, propose a new holistic resource management approach driven by a new memory abstraction, which we call *Deterministic Memory*. The key characteristic of deterministic memory is that the platform—the OS and hardware—guarantees small and tightly bounded worst-case memory access timing. In contrast, we call the conventional memory abstraction as best-effort memory in which only highly pessimistic worst-case bounds can be achieved. We propose to utilize both abstractions to achieve high time predictability but without significantly sacrificing performance. We present deterministic memory-aware OS and architecture designs, including OS-level page allocator, hardware-level cache and DRAM controller designs. We implement the proposed OS and architecture extensions on Linux and gem5 simulator. Our evaluation results, using a set of synthetic and real-world benchmarks, demonstrate the feasibility and effectiveness of our approach.

1 Introduction

High-performance embedded multicore platforms are increasingly demanded in cyber-physical systems (CPS)—especially those in automotive and aviation applications—to cut cost and reduce size, weight, and power (SWaP) of the system via consolidation [32].

Consolidating multiple tasks with different criticality levels (a.k.a. mixed-criticality systems [58, 11]) on a single multicore processor is, however, extremely challenging because interference in the shared hardware resources in the memory hierarchy can significantly alter the tasks’ timing characteristics. Poor time predictability of multicore platforms is a major hurdle that makes their adoption challenging in many safety-critical CPS. For example, the CAST-32A position paper by the avionics certification authorities comprehensively discusses the certification challenges of multicore avionics [12]. Therefore, in aerospace industry, it is a common practice to disable all but one core [29], because extremely pessimistic worst-case-execution times (WCETs) nullify any performance benefits of using multicore processors in critical applications. This phenomenon is also known as the “one-out-of-m” problem [28].

There has been significant research efforts to address the problem. Two common strategies are (1) partitioning the shared resources among the tasks or cores to achieve spatial isolation

and (2) applying analyzable arbitration schemes (e.g., time-division multiple access) in accessing the shared resources to achieve temporal isolation. These strategies have been studied individually (e.g., cache [26, 59, 40], DRAM banks [39, 63], memory bus [64, 41]) or in combination (e.g., [28, 52]). However, most of these efforts improve predictability at the cost of significant *sacrifice in efficiency and performance*.

In this paper, we argue that the fundamental problem that prevents efficient and predictable real-time computing on multicore is the *lack of a proper memory abstraction* to express memory criticality, which cuts across various layers of the system: the application, OS, and hardware. Thus, our approach starts by defining a new OS-level memory abstraction, which we call *Deterministic Memory*. The key characteristic of deterministic memory is that the platform—the OS and hardware—guarantees small and tightly bounded worst-case memory access timing. In contrast, we call the conventional memory abstraction as best-effort memory in which only highly pessimistic worst-case bounds can be achieved.

We propose a new holistic cross-layer resource management approach that leverages the deterministic and best-effort memory abstractions. In our approach, a task can allocate either type of memory blocks in its address space, at the page granularity, based on the desired WCET requirement in accessing the memory blocks. The OS and hardware then apply different resource management strategies depending on the memory type. Specifically, predictability focused strategies, such as resource reservation and predictable scheduling, shall be used for deterministic memory while average performance and efficiency focused strategies, such as space sharing and out-of-order scheduling, shall be used for best-effort memory. Because neither all tasks are time-critical nor all memory blocks of a time-critical task are equally important with respect to the task’s WCET, our approach enables the possibility of achieving high time predictability without significantly affecting performance and efficiency through the selective use of deterministic memory.

While our approach is a generic framework that can be applied to any shared hardware resource management, in this paper, we particularly focus on shared cache and main memory, and demonstrate the potential benefits of our approach in the context of shared cache and DRAM related resource management. Specifically, we describe OS extensions and an OS-level memory allocation method to support deterministic memory. We then describe a deterministic memory-aware cache design that provides the same level of cache space isolation of the conventional way-based partitioning techniques, while achieving significantly higher cache space utilization. We also describe a deterministic memory-aware DRAM controller design that extends a previously proposed real-time memory controller [55] that can achieve similar predictability benefits with minimal DRAM space waste.

We implement the deterministic memory abstraction and an OS-level memory allocator (replacing Linux’s buddy allocator) in Linux 3.13 kernel and implement the proposed deterministic-memory aware memory hierarchy hardware extensions (in MMU, TLB, cache and DRAM controller) in the gem5 full-system simulator [10], which models a high-performance (out-of-order) quad-core platform as baseline. We evaluate the system using a set of synthetic and real-world benchmarks, which include benchmarks from EEMBC [2], SD-VBS [57] and SPEC2006 [20] suites. The results demonstrate the same degree of isolation with respect to the conventional way-based cache partitioning for real-time tasks while improving the cache hit rate of co-scheduled non-real-time workloads sharing the machine by 39% on average.

The main contributions of this work are as follows:

- We propose a new OS-level memory abstraction, which we call *Deterministic Memory*, that enables efficient cross-layer resource management, which balance time predictability and resource efficiency.
- We present a concrete system design—from the OS down to the entire memory hierarchy,

including shared cache and DRAM controller designs—that demonstrate the potential benefits of the new memory abstraction. The key contribution of our design is its Memory Management Unit (MMU) based approach that provides flexible, fine-grained (page-granularity) resource management across the entire memory hierarchy.

- We implement a realistic prototype system on a Linux kernel and a cycle-accurate full system simulator.¹ We also provide extensive empirical results, using both synthetic and real-world benchmarks, that demonstrates the effectiveness of our approach.

The remainder of the paper is organized as follows. Section 2 provides background and motivation. Section 3 describes the proposed Deterministic Memory abstraction. Section 4 provides an overview of the deterministic memory-aware system design. Section 5 present DM-aware timing analysis. Section 6 details our prototype implementation. Section 7 presents evaluation results. We review related work in Section 8 and conclude in Section 9.

2 Background and Motivation

In this section, we describe why the standard uniform memory abstraction is a fundamental limitation for the development of efficient and predictable real-time computing infrastructures.

CPU-centric Abstractions and Resource Management. Traditionally, the CPU has been the main focus of resource management in real-time systems. This is because, in a uniprocessor, only one task at a time can access the entire memory hierarchy. As such, CPU scheduling decisions have a predominant impact on the response time of real-time tasks. Therefore, CPU-centric abstractions such as core, task and task priority have been the primary focus of resource management. Multicore platforms have become mainstream over the last decade. Extensive inter-core hardware resource sharing in the memory hierarchy heavily impacts the timing of tasks. Hence, CPU time management is not anymore the sole dimension to explore when reasoning about the temporal behavior of a system. Various OS-level and hardware-level solutions have been proposed to manage shared resources in the memory hierarchy with the goal of improving time predictability (we will provide a comprehensive review of related work in Section 8). Nonetheless, in most approaches, CPU-centric abstractions are still most widely used to perform allocation and scheduling of shared resources in the memory hierarchy. Unfortunately, CPU-centric abstractions are often too coarse-grained to enact accurate management policies on memory hierarchy resources, such as cache lines and main memory pages. For instance, when a fraction of cache space is reserved for a task, it cannot be used by other tasks, even if it is not fully utilized by the reserved task. Likewise, when DRAM banks are reserved for a task, they cannot be utilized by other tasks, resulting in under-utilized DRAM space, even though not all memory of the task may need to be allocated on the reserved DRAM bank.

The Uniform Memory Abstraction. Operating systems and hardware traditionally have provided a simple uniform memory abstraction that hides all the complex details of the memory hierarchy. When an application requests to allocate more memory, the OS simply maps the necessary amount of *any* physical memory pages available at the time to the application’s address space—without considering (i) how memory pages are actually mapped to shared hardware resources in the memory hierarchy, and (ii) how the page(s) selected for allocation will affect application performance. Likewise, the underlying hardware components treat all memory accesses from the CPU as equal without any regard to differences in criticality and timing requirements in allocating and scheduling the requests.

¹We provide the modified Linux kernel source, the modified gem5 simulator source, and the simulation methodology at <http://github.com/CSL-KU/detmem> for replication study.

We argue that this uniform memory abstraction is fundamentally inadequate for multicore systems because it prevents the OS and the memory hierarchy hardware from making informed decisions in allocating and scheduling access to shared hardware resources. As such, we believe that new memory abstractions are needed to enable both efficient and predictable real-time resource management. It is important to note that the said abstractions should not expose too many architectural details about the memory hierarchy to the users, to ensure portability in spite of rapid changes in hardware architectures.

3 Deterministic Memory Abstraction

In this section, we introduce the *Deterministic Memory* abstraction to address the aforementioned challenges.

We define deterministic memory as special memory space for which the OS and hardware guarantee small and tightly bounded worst-case access delay. In contrast, we call conventional memory as best-effort memory, for which only highly pessimistic worst-case bounds can be achieved. Both memory types are supported by the OS and hardware in a single multicore system. These memory abstractions allow applications to express their memory access timing requirements in an architecture-neutral way, while leaving the implementation details to the OS and to the hardware architecture. This enables us to achieve predictable, analyzable and efficient management of shared hardware resources in multicore platforms, as we discuss in the rest of the section.

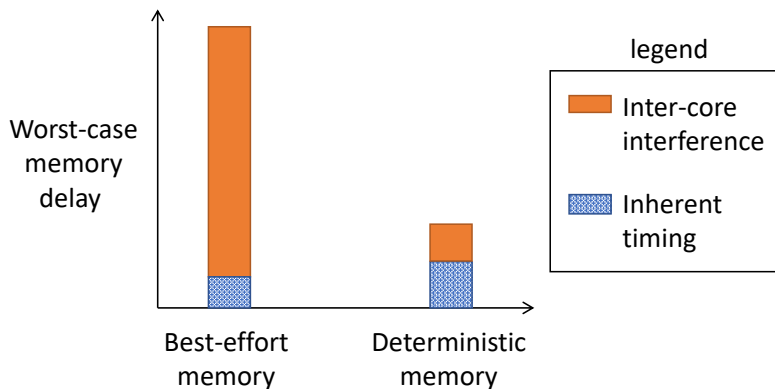

Figure 1: Conceptual differences of deterministic and best-effort memories

Figure 1 shows the conceptual differences between the two types of memory with respect to worst-case memory access delay. For clarity, we divide memory access delay into two components: *inherent access delay* and *inter-core interference delay*. The inherent access delay is the minimum necessary timing in isolation. In this regard, deterministic memory can be slower—in principal, but not necessarily—than best-effort memory, as its main objective is predictability and not performance, while in the case of best-effort memory, the reverse is true. The inter-core interference delay is, on the other hand, an additional delay caused by concurrently sharing hardware resources between multiple cores. This is where the two memory types differ the most. For best-effort memory, the worst-case delay bound is highly *pessimistic* mainly because the inter-core interference delay can be severe. For deterministic memory, on the other hand, the worst-case delay bound is *small and tight* as the inter-core interference delay is minimized.

Table 1 shows general spatial and temporal resource management strategies of the OS and hardware to achieve the differing goals of the two memory types. Here, we mainly focus

	Space allocation	Request scheduling	WCET bounds
Deterministic memory	Dedicated resources	Predictability focused	Tight
Best-effort memory	Shared resources	Performance focused	Pessimistic

Table 1: Differences in resource management strategies.

on shared hardware resources, such as shared cache, DRAM banks, memory controllers, and buses. In contrast, we do not focus on core-private hardware resources such as private (L1) caches as they do not generally contribute to inter-core interference.

In the deterministic memory approach, a task can map all or part of its memory from the deterministic memory. For example, an entire address space of a real-time task can be allocated from the deterministic memory; or, only the important buffers used in a control loop of the real-time task can be allocated from the deterministic memory, while temporary buffers used in the initialization phase are allocated from the best-effort memory.

Our key insight is that *not all memory blocks of an application are equally important with respect to the application’s WCET*. For instance, in the applications we profiled in Section 7.1, only a small fraction of memory pages account for 80% of memory accesses to the shared memory hierarchy (shared L2 and DRAM).

Based on this insight, we now provide a detailed design and implementation of deterministic memory-aware OS and architecture extensions with a goal of achieving high efficiency and predictability.

4 System Design

In this section, we first provide a high-level overview of a deterministic-memory based multicore system design (Section 4.1). We then describe necessary small OS and hardware architecture extensions to support the deterministic/best-effort memory abstractions (Section 4.2). Lastly, we describe deterministic memory-aware cache and DRAM management frameworks (Section 4.3 and 4.4, respectively).

4.1 Overview

Figure 2a shows the virtual address space of a task using both deterministic and best-effort memory under our approach. From the point of view of the task, the two memory types differ only in their worst-case timing characteristics. The deterministic memory is realized by extending the *virtual memory system* at the page granularity. Whether a certain page is deterministic or best-effort memory is stored in the task’s page table and the information is propagated throughout the shared memory hierarchy, which is then used in allocation and scheduling decisions made by the OS and the memory hierarchy hardware.

Figure 2b shows the system-level (OS and architecture) view of a multicore system supporting the deterministic and best-effort memory abstractions. In this example, each core is given one cache way and a DRAM bank which will be used to serve deterministic memory for the core. One cache way and four DRAM banks are assigned for the best-effort memory of all cores. Here, the highlighted deterministic memory-aware memory hierarchy refers to hardware support for the deterministic memory abstraction.

It is important to note that the support for deterministic memory is generally more *expensive* than that of best-effort memory in the sense that it may require dedicated space, which may be wasted if under-utilized, and predictability focused scheduling, which may not offer highest performance. As such, to improve efficiency and performance, it is desirable

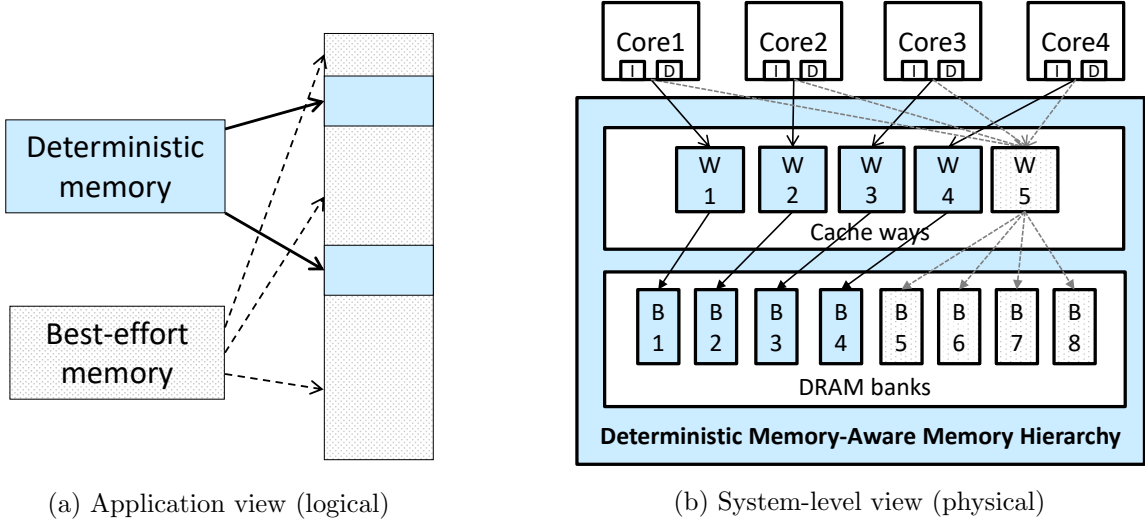

Figure 2: Logical and physical mappings of the *deterministic* and *best-effort* memory abstractions

to use as little deterministic memory as possible as long as the desired worst-case timing of real-time tasks can be satisfied.

4.2 OS and Architecture Extensions for Deterministic Memory Abstraction Support

The deterministic memory abstraction is realized by extending the OS’s virtual memory subsystem. Whether a certain page has the deterministic memory property or not is stored in the corresponding page table entry. Note that in most architectures, a page table entry contains not only the virtual-to-physical address translation but also a number of auxiliary attributes such as access permission and cacheability. The deterministic memory can be encoded as just another attribute, which we call a *DM* bit, in the page table entry.² The OS is responsible for updating the DM bits in each task’s page tables. The OS provides interfaces for applications to declare and update their deterministic/best-effort memory regions at the page granularity. Any number of memory regions of any sizes (down to a single page) within the application’s address space can be declared as deterministic memory (the rest is best-effort memory by default).

In a modern processor, the processor’s view of memory is determined by the Memory Management Unit (MMU), which translates a virtual address to a corresponding physical address. The translation information, along with other auxiliary information, is stored in a page table entry, which is managed by the OS. Translation Look-aside Buffer (TLB) then caches frequently accessed page table entries to accelerate the translation speed. As discussed above, in our design, the *DM* bit in each page table entry indicates whether the page is for deterministic memory or for best-effort memory. Thus, the TLB also store the *DM* bit and pass the information down to the memory hierarchy.

Figure 3 shows this information flow of deterministic memory. Note that bus protocols (e.g., AMBA [5]) also should provide a mean to pass the deterministic memory information into each request packet. In fact, many of the existing bus protocols already support some forms of priority information as part of bus transaction messages³. These fields are currently

²In our implementation, we currently use an unused memory attribute in the page table entry of the ARM architecture; see Section 6 for details.

³For example, ARM AXI4 protocol includes a 4-bit QoS identifier AxQOS signal [5] that supports up to 16

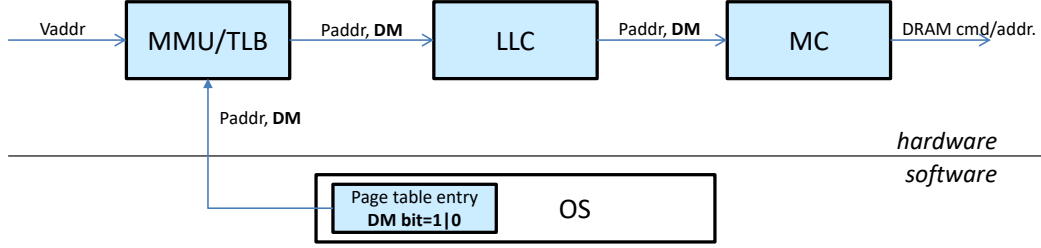

Figure 3: Deterministic memory-aware memory hierarchy: Overview

used to distinguish priority between bus masters (e.g., CPU vs. GPU vs. DMA controllers). A bus transaction for deterministic memory can be incorporated into these bus protocols, for example, as a special priority class. The deterministic memory information can then be utilized in mapping and scheduling decisions made by the respective hardware components in the memory hierarchy.

In the following, we focus on cache and DRAM controllers and how the deterministic memory information can be utilized in these important shared hardware resources.

4.3 Deterministic Memory-Aware Shared Cache

In this subsection, We present a deterministic memory-aware shared cache design that provides the same isolation benefits of traditional way-based cache partitioning techniques while achieving higher cache space utilization.

Way-based Cache Partitioning: In a standard way-based partitioning, which is supported in several COTS multicore processors [17, 6], each core is given a non-overlapping subset of cache ways. When a cache miss occurs, a new cache line (loaded from the memory) is allocated on one of the assigned cache ways in order not to evict useful cache lines of the other cores that share the same cache set. An important shortcoming of way-partitioning is, however, that its partitioning granularity is coarse (i.e., way granularity) and the cache space of each partition may be wasted if it is underutilized. Furthermore, even if fine-grain partition adjustment is possible, it is not easy to determine the “optimal” partition size of a task because the task’s behavior may change over time or depending on the input. As a result, it is often a common practice to conservatively allocate sufficient amount of resource (over-provisioning), which will waste much of the reserved space most of the time.

Deterministic Memory-Aware Replacement Algorithm: We improve way-based partitioning by taking advantage of the deterministic memory abstraction. The basic approach is that we use way partitioning only for deterministic memory accesses while allowing best-effort memory accesses to use all the cache ways that do not currently hold deterministic cache lines.

Figure 4 shows an example cache status of our design in which two cores share a 4-set, 5-way set-associative cache. In our design, there is a *DM* bit per cache line stored along with other status bits (e.g. *valid* and *dirty* bits) to indicate whether a cache line is for deterministic memory or best-effort memory (see the upper-right side of Figure 4). When inserting a new cache line (of a given set), if the requesting memory access is for deterministic memory, then the victim line is chosen from the core’s way partition (e.g., way 0 and 1 for Core 0 in Figure 4). On the other hand, if the requesting memory access is for best-effort memory, the victim line is chosen from ways that do not hold deterministic cache lines (e.g., in set 0, all but way 2 are best-effort cache lines; in set 1, on the other hand, only the way 4

different priority classes for bus transactions.

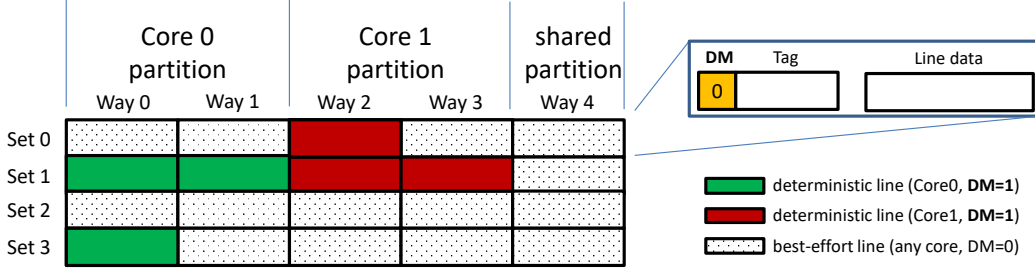

Figure 4: Deterministic memory-aware cache management

is best-effort cache line.).

Input : $PartMask_i$ - way partition mask of Core i
 $DetMask_s$ - deterministic ways of Set s

Output: $victim$ - the victim way to be replaced.

```

1 if  $DM == 1$  then
2   if  $(PartMask_i \wedge \neg DetMask_s) \neq NULL$  then
3     // evict a best-effort line first
4      $victim = LRU(PartMask_i \wedge \neg DetMask_s)$ 
5      $DetMask_s | = 1 \ll victim$ 
6   else
7     // evict a deterministic line
8      $victim = LRU(PartMask_i)$ 
9   end
10 else
11   // evict a best-effort line
12    $victim = LRU(\neg DetMask)$ 
13 end
14 return  $victim$ 

```

Algorithm 1: Deterministic memory-aware cache line replacement algorithm.

Algorithm 1 shows the pseudo code of the cache line replacement algorithm. As in the standard cache way-partitioning, we assign dedicated cache ways for each core, denoted as $PartMask_i$, to eliminate inter-core cache interference. Note that $DetMask_s$ denotes the bitmask of the set s 's cache lines that contain deterministic memory. If a request from core i is a deterministic memory request ($DM = 1$), then a line is allocated from the core's cache way partition ($PartMask_i$). Among the ways of the partition, the algorithm first tries to evict a best-effort cache line, if such a line exists (Line 3-4). If not (i.e., all lines are deterministic ones), it chooses one of the deterministic line as the victim (Line 6). On the other hand, if a best-effort memory is requested ($DM \neq 1$), it evicts one of the best-effort cache lines, but not any of the deterministic cache lines (Line 9). In this way, even though the deterministic cache lines of a partition are completely isolated from any accesses other than the assigned core of the partition, the under-utilized cache lines of the partition can still be utilized as best-effort cache lines of all cores.

Deterministic Memory Cleanup: Note that a core's way partition would eventually be filled with deterministic cache lines (ones with $DM = 1$) if left unmanaged (e.g., scheduling multiple different real-time tasks on the core). This would eliminate the space efficiency gains of using deterministic memory because the deterministic memory cache lines cannot be evicted by best-effort memory requests.

In order to keep only a minimal number of deterministic cache lines on any given partition in a predictable manner, our cache controller provides a special hardware mechanism that clears the *DM* bits of all deterministic cache lines, effectively turning them to best-effort cache-lines. This mechanism is used by the core’s OS scheduler on each context switch so that the deterministic cache-lines of the previous tasks can be evicted by the current task. When the deterministic-turned-best-effort cache-lines of a task are accessed again and they still exist in the cache, they will be simply re-marked as deterministic without needing to reload from memory. In the worst case, however, all deterministic cache lines of a task shall be reloaded when the task is re-scheduled on the CPU.

Note that our cache controller reports the number of deterministic cache lines that are cleared on a context switch back to the OS. This information can be used to more accurately estimate cache-related preemption delays (CRPD) [4].

Guarantees: The premise of the proposed cache replacement strategy is that a core’s deterministic cache lines will never be evicted by other cores’ cache allocations, hence *preserving the benefit of cache partitioning*. At the same time, non-deterministic cache lines in the core’s cache partition can safely be used as other cores’ best-effort memory requests, hence *minimizing wasted cache capacity* due to partitioning.

Comparison with PRETI: Our DM-aware cache replacement algorithm is similar to several prior mixed-criticality aware cache designs [33, 31, 62]. The most closely related work is PRETI [33], which also modifies LRU to be mixed-criticality-aware. There are, however, several notable differences. First, PRETI uses the thread(task)-id to distinguish critical and non-critical cache accesses, whereas we use MMU, which support finer, page granularity criticality control. Second, in PRETI, cache-lines reserved to a critical thread can only be released on its termination. In contrast, we provide a DM-cleanup mechanism activated at preemption, which enables efficient reclamation of deterministic memory cache-lines at each context-switch. Third, PRETI’s replacement algorithm provides a firm cache space reservation capability [45]: i.e. a real-time task can utilize under-utilized cache space beyond its dedicated private space, whereas our replacement algorithm does not allow such additional cache space utilization. Lastly, while prior works mainly focus on cache re-design, our main goal is to provide a unified framework—the deterministic memory abstraction—which can carry information about time-sensitivity of memory space not only in cache, but also in the OS and throughout shared resources in the memory hierarchy. We will discuss how a traditional DRAM controller can be extended to support deterministic memory abstraction in the next sections.

4.4 Deterministic Memory-Aware DRAM Controller

In this subsection, we present a deterministic memory-aware DRAM controller design, which, in collaboration with our OS-level support, provides strong spatial and temporal isolation for deterministic memory accesses while also enables efficient processing of best-effort memory accesses.

First, the OS actively controls on which DRAM bank a page frame is allocated. Specifically, the OS reserves a small number of banks for each core to be used as deterministic memory for the core, while the rest of the banks are used for best-effort memory of all cores, as shown in Figure 5a (also in Figure 2b). When the OS allocates memory pages of an application task, deterministic memory pages of the task shall be allocated on core-private DRAM banks while best-effort memory pages shall be allocated on shared DRAM banks to eliminate DRAM bank-level inter-core interference [25].

Second, the memory controller (MC) implements a *two-level scheduling* algorithm that first prioritizes deterministic memory requests over the ones for best-effort memory. For deterministic memory requests, we use a round-robin scheduling policy as it offers stonger

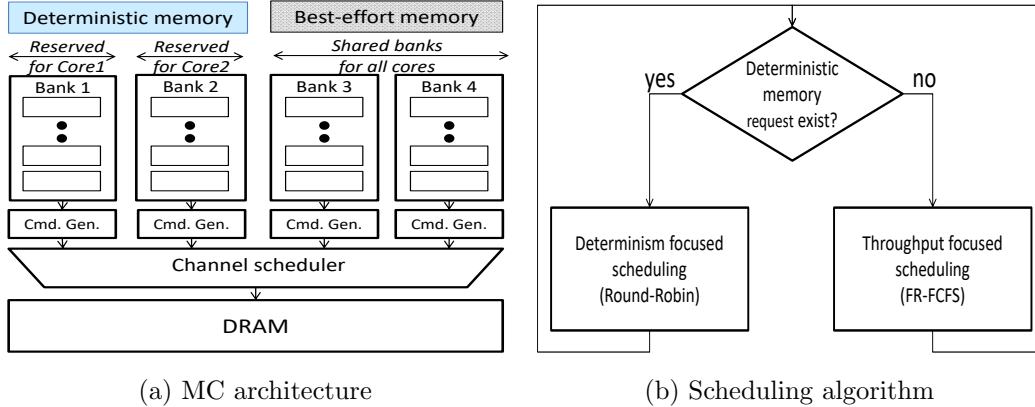

Figure 5: Deterministic memory-aware memory controller architecture and scheduling algorithm.

time predictability [44], while we use FR-FCFS for scheduling best-effort memory requests as it offers high average throughput [47]. Figure 5b shows the flowchart of the scheduler. Note, however, strictly prioritizing deterministic memory requests could starve best-effort memory requests indefinitely. Since our analysis method (Section 5) assumes the existence of a pessimistic worst-case bound for best-effort memory the two-level scheduling algorithm limit the maximum number of consecutive processing of deterministic memory requests in case best-effort memory requests exist. This enables us to achieve tightly bounded worst-case timing for deterministic memory while pessimistic timing for best-effort memory.

Our design is inspired by prior mixed-criticality memory controller proposals [27, 23, 55], all of which, like us, apply different scheduling algorithms depending on memory criticality, although detailed designs (and assumptions) are varied. In this work, we particularly use the MEDUSA memory controller design [55] as our baseline, but improves its efficiency by leveraging the DM-bit information passed down to the memory controller. Specifically, in [55], a real-time task has to allocate its entire memory space from the reserved DRAM banks, even when much of its allocated memory is never used in the time-critical part. In contrast, our design can *reduce* the amount of memory allocated in the reserved DRAM banks by only allocating the deterministic memory pages. This allows us to accommodate more real-time tasks with the same amount of reserved DRAM banks.

The necessary changes to support deterministic memory is small. Specifically, the original MEDUSA controller [55] uses a set of memory controller specific hardware registers to identify reserved DRAM banks of the cores. Instead, our modified memory controller design simply uses the DM-bit information in each memory request to determine memory criticality. Other mixed-criticality real-time memory controllers designs [27, 23] also similarly rely on memory-controller-specific hardware registers to identify memory criticality. Thus, we believe they also can be easily augmented to support the deterministic memory abstraction.

4.5 Other Shared Hardware Resources

We briefly discuss other potential deterministic memory-aware shared hardware designs.

As shown in [56], the miss-status-holding-registers (MSRHs) in a shared non-blocking cache can be a significant source of inter-core interference if the number of MSRHs in the shared cache is insufficient to support the parallelism of the cores. Contention in MSRHs can be avoided by simply having a sufficient MSRHs, as did in our evaluation setup, if it is difficult for reasons discussed in [56], deterministic memory-aware MSRH management can be alternatively considered. For example, one possible DM-aware approach is that reserving

some per-core MSHR entries to handle deterministic memory and sharing the rest of MSHR entries for best-effort memory requests from all cores.

Deterministic memory-aware TLB can also be considered. Although a TLB is not typically shared among the cores, it is conceivable to design a DM-aware TLB replacement policy that reserves some TLB entries for deterministic memory that cannot be evicted by access to best-effort memory addresses. Such a policy can be useful to reduce CRPD at task preemption within a core.

5 Timing Analysis

In this section, we show how to extend traditional response time analysis (RTA) [8] to account for deterministic and best-effort memory abstractions.

The approach in our analysis is the following. First, real-time tasks' parameters are derived **in isolation**. A task is said to execute in isolation if: (i) it executes alone on the assigned core under a given resource partition; and (ii) all the other $N_{proc} - 1$ cores are idle or offline. Next, we analytically derive a worst-case response time [8] that holds when the task under analysis is co-scheduled with other tasks in the same core, and when all the N_{proc} cores are active.

In our system, a real-time task τ_i is represented by the following parameters:

$$\tau_i = \{C_i, T_i, D_i, DM_i, BM_i\} \quad (1)$$

where C_i is the WCET of the τ_i when it executes in isolation; T_i is the period of the task; D_i is the deadline of the task; DM_i represents the maximum number of deterministic memory requests that suffer inter-core interference; BM_i is the maximum number of best-effort memory requests that are subject to inter-core interference. Note that in the proposed DM-aware system described earlier, DM_i accounts only a subset of deterministic memory accesses that result in L2 misses because the L2 hit accesses would not suffer inter-core interference. On the other hand BM_i would represent a subset of best-effort memory accesses that result in L1 misses (not L2 misses). This is because for best-effort memory, L2 cache space is shared, and, in the worst-case, all of them will have to be fetched from the memory controller. Also note that all these parameters can be obtained in isolation and are still valid when all the N_{proc} cores are active.

We then can compute τ_i 's worst-case memory interference delay I_i as follows:

$$I_i = DM_i \times RD^{dm} + BM_i \times RD^{bm}, \quad (2)$$

where RD^{dm} and RD^{bm} denote the *worst-case inter-core interference delay* of (i) a deterministic memory request and (ii) a best-effort memory request, respectively. By our system design, RD^{dm} is small and tightly bounded because accesses to deterministic memory suffer minimal (or zero) inter-core interference at the shared L2 cache and the shared DRAM. On the other hand, RD^{bm} will be substantially higher and highly pessimistic because we have to pessimistically assume access to best-effort memory will always miss the L2 cache and suffer high queueing delay at the DRAM controller.

Traditional RTA analysis can then be performed by finding the first value of k such that $R_i^{(k+1)} = R_i^{(k)}$ (task is schedulable) or such that $R_i^{(k)} > D_i$ (task is not schedulable), given that $R_i^{(0)} = C_i + I_i$ and that $R_i^{(k+1)}$ is calculated as:

$$R_i^{(k+1)} = C_i + I_i + \sum_{\tau_j \in hp(i)} \left\lceil \frac{R_i^{(k)}}{T_j} \right\rceil \cdot (C_j + I_j), \quad (3)$$

undefined memory types. For deterministic memory, we define one of the unused memory types as the deterministic memory type, by updating PRRR and NMRR registers at boot time. A page is marked as deterministic memory when the corresponding page table entry’s memory attributes point to the deterministic memory type.

At the user-level, we extend the Linux’s ELF (Executable and Linkable Format [13]) loader and the `exec` system call implementation. We currently use a special file extension to inform ELF loader whether to mark the entire memory address or a subset of task’s memory pages as deterministic memory. For fine-grained control, the virtual page numbers which might be marked as deterministic memory are currently hard-coded in the kernel source and a subset of them is selected based on the arguments passed to the `exec` system call. In the future, we will use kernel debugfs interface to efficiently communicate page information. Also, the ELF header of a program binary can be used instead to encode the virtual page numbers.

Within the Linux kernel, a task’s virtual address space is represented as a set of *memory regions*, each of which is represented by a data structure, `vm_area_struct`, called a VMA descriptor. Each VMA descriptor contains a variety of metadata about the memory region, including its memory type information. Whenever a new physical memory block is allocated (at a page fault), the kernel uses the information stored in the corresponding VMA descriptor to construct the page table entry for the new page. We added a new flag `VM_DETMEM` to indicate the deterministic memory type in a VMA descriptor. When a page fault happens on accessing a memory address, if the `VM_DETMEM` flag of the memory region corresponding to the address is set, or the address falls within one of the virtual page numbers hard-coded in the kernel then OS sets the `TEX[0]`, `C` and `B` bits in allocating the page for the address to mark that it is a deterministic memory page.

Note that the above code changes are minimal. In total, we only added/modified less than 200 lines of C and assembly code over 12 files in the Linux kernel source tree. Furthermore, because most changes are in page table descriptors and their initialization, no runtime overhead is incurred by the code changes.

We then applied the PALLOC patch [63], which replaces the buddy allocator to support DRAM bank partitioning. We further extended the PALLOC allocator to support deterministic memory. Specifically, we extended PALLOC’s cgroup interface to declare a subset of banks to be used as private banks for the cgroup’s deterministic memory pages and another subset of banks to be used for best-effort memory pages.

6.3 Gem5 Extensions

We modified the Gem5 full-system simulator as follows.

MMU and TLB. The deterministic memory type information stored in the page table is read by the MMU and passed throughout the memory hierarchy. When a page fault occurs, the MMU performs the page table walk to determine the physical address of the faulted virtual address. In the process, it also reads other important auxiliary information such as memory attribute and access permission from the page table entry and stores them into a TLB entry in the processor. The deterministic memory attribute is stored alongside with the other memory attributes in the TLB entry. Specifically, we add a single bit in the gem5’s implementation of a TLB entry to indicate the deterministic memory type. As a reference, Cortex-A17’s TLB entry has 80 bits and a significant fraction of the bits are already used to store various auxiliary information [7] or reserved for future use. Thus, requiring a single bit in a TLB entry does not pose significant overhead in practice. We also extend the memory request packet format in the gem5 simulator to include the deterministic memory type information. In this way, the memory type information of each memory request can be passed down through the memory hierarchy. In real hardware, bus protocols should be

extended to include such information. As discussed earlier, existing bus protocols such as AXI4 already support the inclusion of such additional information in each bus packet [5].

Cache Controller. The gem5’s cache subsystem implements a flexibly configurable non-blocking cache architecture and supports standard LRU and random replacement algorithms. Our modifications are as follows. First, we extend gem5’s cache controller to support a standard way-based partitioning capability ⁵. The way partition is configured via a set of programmable registers. When a cache miss occurs, instead of replacing the cache line in the LRU position, the controller replaces the LRU line among the configured ways for the core. The way-based partitioning mechanism is used as a baseline. On top of the way-based partitioning, we implement the proposed deterministic memory-aware replacement and cleanup algorithms (Section 4.3).

DRAM Controller. The baseline gem5’s memory controller subsystem supports a standard FR-FCFS algorithm [19]. We extended the memory controller subsystem to support the two-level scheduling algorithm described in [55]. The two-level scheduler is modified to leverage the deterministic memory bit passed to the memory controller as part of each memory request bus transaction. Also, to prevent starvation of best-effort memory requests, we limit the maximum consecutive deterministic memory request processing to 30 when one or more best-effort memory requests are in the memory controller’s queue.

7 Evaluation

In this section, we present evaluation results to support the feasibility and effectiveness of the proposed deterministic memory-aware system design.

System Setup: for OS, we use a modified Linux kernel 3.13, which implements modifications explained in Section 6.2 to support the deterministic memory abstraction. In terms of hardware, we use a modified gem5 full system simulator, which implements the proposed deterministic memory support described in Section 6.3. The simulator setup is configured as a quad-core out-of-order processor (O3CPU model [3]) with per-core private L1 I/D caches, a shared L2 cache, and a shared DRAM. The baseline architecture parameters are shown in Table 2. We use the `mlockall` system call to allocate all necessary pages of each real-time application at the beginning so as to avoid page faults during the rest of program’s execution. In addition, we enabled the kernel configuration option `NO_HZ_FULL` to reduce unnecessary scheduler-tick interrupts.

Table 2: Simulator configuration

Core	Quad-core, out-of-order, 2 GHz, IQ: 96, ROB: 128, LSQ: 48/48
L1-I/D caches	Private 16/16 KiB (2-way), MSHRs: 2(I)/6(D)
L2 cache	Shared 2 MiB (16-way), LRU, MSHRs: 56, hit latency: 12
DRAM Controller	Read buffer: 64, write buffer: 64, open-adaptive page policy
DRAM module	LPDDR2@533MHz, 1 rank, 8 banks

7.1 Real-Time Benchmark Characteristics

We use a set of EEMBC [2] automotive and SD-VBS [57] vision benchmarks (input: sim) as real-time workloads. We profile each benchmark, using the gem5 simulator, to better understand memory characteristics of the benchmarks.

⁵<https://github.com/farzadfch/gem5-cache-partitioning>

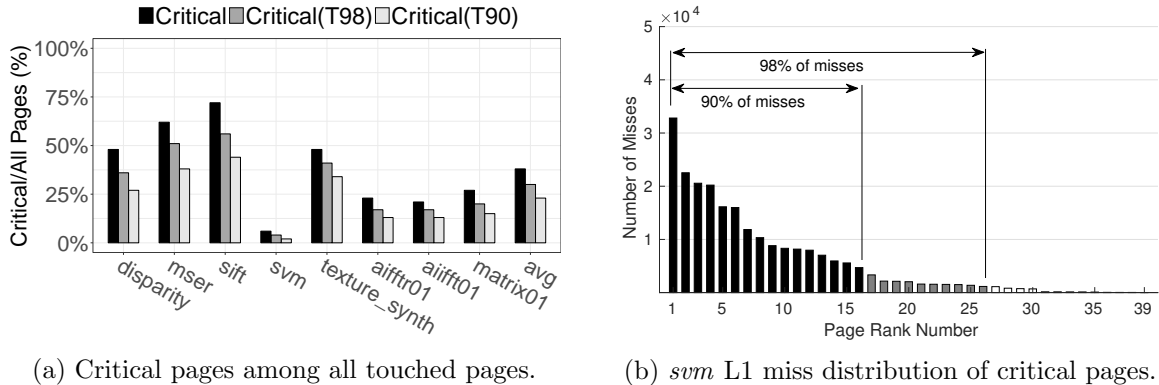

Figure 7: Space and temporal characteristics of application memory pages. Critical pages refer to the touched pages within the main loop of each benchmark.

Figure 7a shows the ratio between the number of accessed pages within the main loop and the the number of all accessed pages of each benchmark; the pages accessed in the loop are denoted as critical pages. To further analyze the characteristics of the critical pages, we profiled L1 cache misses of each critical page to see which pages contribute most to the overall L1 cache misses. *Critical(T98)* shows the ratio between number of ‘top’ critical pages which contribute to 98% of L1 cache misses the the number of all accessed pages. The same is for *Critical(T90)* except that 90% of L1 cache misses are taken into account. As it can be seen in this figure, 38% (on average) of pages are critical pages, and this number can be as low as 6% in the case of *svm*. This means that the rest of the pages are accessed during the initialization and other non-time-critical procedures. This is further reduced to 23% of the touched pages if 90% of L1 cache misses are taken in to account.

Note that in our system setup, the private L1 cache misses are directed to the shared L2 cache, which is shared by all cores. Thus, those pages that show high L1 misses likely contribute most to the WCET of the application because they can suffer from high inter-core interference due to contention at the shared L2 cache and/or the shared DRAM. Figure 7b shows how the top critical pages are determined for *svm* benchmark. The pages are ranked based on the number of L1 cache misses. In the case of *svm*, the top 26 and 16 pages account for 98% and 90% of misses. These pages are 4% and 2% of all the touched pages, respectively, as it is shown in Figure 7a. This suggests even among the critical pages, certain pages contribute more to WCET than the rest of the critical pages.

The results show that selective, fine-grained application of deterministic memory can significantly reduce WCETs while minimizing resource waste.

7.2 Effects of Deterministic Memory-Aware Cache

In this experiments, we study the effectiveness of deterministic memory-aware cache. The basic experimental setup is that, we run a real-time task on Core 3 and three instances of a memory intensive synthetic benchmark as best-effort co-runners on Core 0 through 2; we use the Bandwidth benchmark with write memory access pattern [56] as the co-runners. Note that the working-set size of a best-effort co-runner is chosen so that the sum of all co-runners is equal to the size of the entire L2 cache. This will increase the likelihood to evict the cache lines of the real-time task, if its cache lines are not protected.

We evaluate the system with 5 different configurations: *NoP*, *WP*, *DM(A)*, *DM(T98)*, *DM(T90)*, and *DM(A)*. In *NoP*, the L2 cache is shared among all cores without any restrictions. In *WP*, the L2 cache is partitioned using the standard way-based partitioning method, and

4 ways are given to each core. In DM(A), the entire address space of the real-time task is marked as deterministic memory, while in DM(T98), only the pages which are accessed in the main loop of the task and account for 98% of the L1 misses are marked as deterministic. DM(T90) is the same as DM(T98) except that pages which account for 90% of the misses are marked as deterministic. In all DM configurations, each core is given 1/4 of the cache ways for the core’s deterministic memory. Note that, in this experiment, the results for DM(A) will be similar to that of PRETI [33], because, in both systems, a dedicated cache space is guaranteed to a real-time task’s entire memory space, while the presence of best-effort tasks would prevent the real-time task from utilizing additional cache space in PRETI.

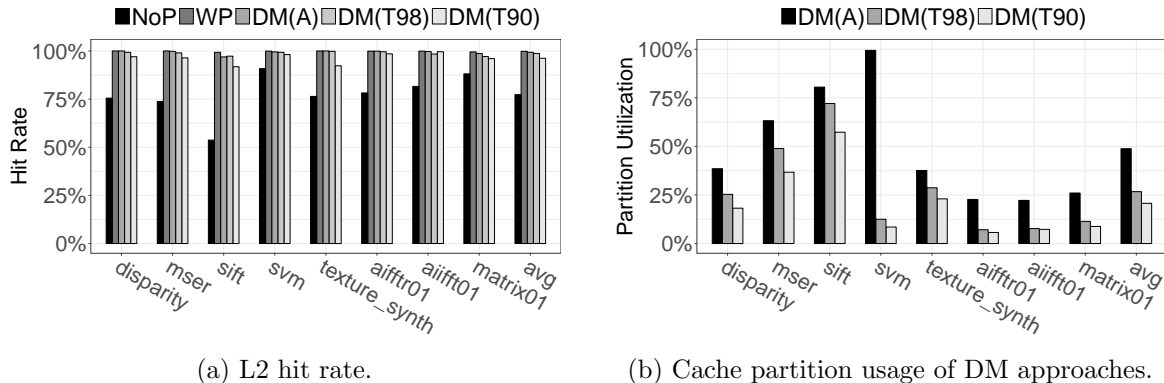

Figure 8: L2 hit-rate and cache space usage (deterministic memory only) of real-time tasks.

Effects on Real-Time Tasks. Figure 8a compares the L2 hit rates of real-time tasks for each system configuration. As can be seen in the figure, hit rate can be as low as 0.54 (54%) in NoP. This configuration achieves low L2 cache hit rates because the cache lines of the real-time benchmarks are evicted by the co-running *Bandwidth* benchmarks. In WP, on the other hand, all benchmarks show close to 100% hit rates. This is because the dedicated private L2 cache space (4 out of 16 cache ways = 512KB) is sufficient to hold the working-sets of the benchmarks and the co-runners cannot evict the cache lines of the real-time tasks. The hit rates are also close to 100% in DM(A) because the co-runners are not allowed to evict any of the cache lines allocated for the real-time tasks, and their entire spaces are marked as deterministic memory. In DM(T98) and DM(90), not all pages are marked as deterministic memory. As the result, the co-runners can evict the some the best-effort cache lines of the real-time tasks and this in turn results in slight reduction in the hit rates.

We instrumented the gem5 simulator to identify how many cache lines are occupied for deterministic memory, by checking the *DM* bit in the cache lines. Figure 8b shows the percentage of the cache lines allocated by the deterministic memory cache lines. On average, 49%, 27%, and 21% of cache-lines are deterministic memory cache-lines in DM(A), DM(T98), and DM(T90), respectively. Note that when the conventional way partitioning is being used (WP), the unused cache space in the private partition is essentially wasted as no other task can utilize it. In the deterministic memory-aware cache, the best-effort tasks can use the rest of the partition that is not flagged as deterministic memory. Thus, the hit rate of the best-effort tasks can potentially be improved as more cache space will be available to them. This will be shown in the following experiment.

Effects on Best-Effort Tasks. To study the effect of deterministic memory-aware cache on realistic best-effort tasks (as oppose the synthetic ones used above), we designed an experiment with the *bzip2* benchmark from SPEC2006 as best-effort task running on Core 0, and 3 instances of a real-time task running on Core 1 through 3. We chose *bzip2* based on the following selection criteria: 1) It must frequently accesses the shared cache; 2)

It must be sensitive to extra cache space (i.e. the hit rate shall be improved if more cache space is given to the benchmark). The *bzip2* meet both requirements according to a memory characterization study [21] by Intel.

Figure 9 shows the results for this experiment. Inset (a) shows the percentage of cache space used by *bzip2* for each real-time task pairing, while inset (b) shows its hit rates. Note first that in WP, *bzip2* can only use 25% of cache space (512kB out of 2MB), as this is the size of its private cache partition. On the other hand, in a deterministic memory-aware cache, *bzip2* can allocate more lines from the private partitions of the other cores which are not marked as deterministic memory cache lines. Consequently, the average hit rate is improved by 39%, 49%, and 50% in DM(A), DM(T98), and DM(T90), compared with that of in WP. It is obvious that more cache lines are allocated by *bzip2* in DM(T98) and DM(T90) compared to DM(A) because the best-effort cache lines of the real-time tasks are shared with *bzip2* in these configurations. Note that the best-effort lines are shared with all of the cores and *bzip2* has to compete with the real-time task to allocate them. We included the result for NoP to show how much cache space *bzip2* can allocate if there is no restrictions in doing so. These numbers can also be seen as the upper-bound cache space that *bzip2* can allocate in the deterministic memory-aware cache. By comparing the cache occupancy in DM(90) and NoP (i.e., “free-for-all” sharing), we see that using deterministic memory-aware cache, *bzip2* is occupying cache space close to it can do as if there were no restrictions on the cache.

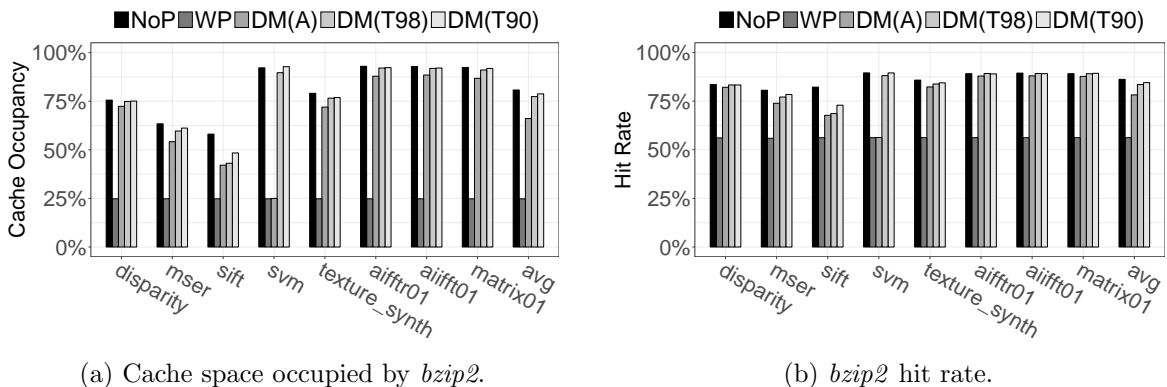

Figure 9: Cache usage and hit rate impact of DM-aware cache to the best-effort task (*bzip2*).

7.3 Effects of Deterministic Memory-Aware DRAM Controller

We evaluate the deterministic memory-aware DRAM controller, using SD-VBS benchmark suite (input: CIF). The use of bigger input ensures that the working-sets of the benchmarks do not fit in the L2 cache and the memory accesses have to go to the main memory. Since the EEMBC benchmarks are cache-fitting and their working set size cannot be adjusted, we removed them from this experiment. We re-profiled the SD-VBS benchmark with the new input, similar to what has been described in 7.1, to determine the critical pages. In this experiment, a real-time task is co-scheduled with three Bandwidth benchmarks which their working-set sizes are set to be 2x larger than the L2 cache size.

Figure 10a shows the normalized slowdown results for different system configurations. *DM(A)*, *DM(T98)*, and *DM(T90)* are the same dm-aware cache configurations as in 7.2. For all DM configurations, each core is given a private DRAM bank for deterministic memory. The remaining four DRAM banks are shared among the cores for best-effort memory. With the DM-aware OS allocator support described in 4.4, the deterministic memory blocks are allocated on the per-core private banks, and the best-effort regions are allocated on the shared

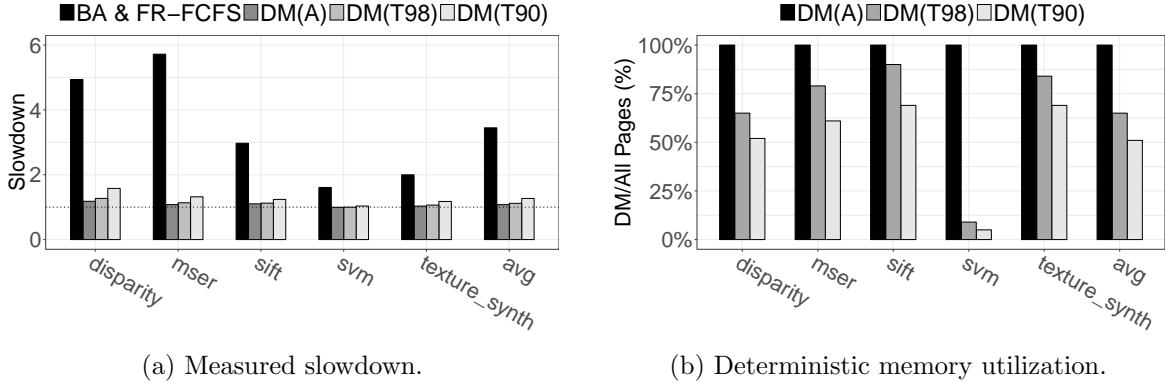

Figure 10: Performance and deterministic memory space impacts of DM-aware DRAM.

banks. In *BA and FR-FCFS* configuration, the FR-FCFS algorithm is used to schedule the memory accesses to the DRAM, and the buddy allocator is used (i.e., no bank control).

Figure 10 shows that the interference in accessing the shared memory can increase the execution time by up to 5.7X (BA&FR-FCFS), and the deterministic memory system is capable of effectively reducing this interference and bounding WCET while efficiently using the DRAM private bank (all DM configurations).

Figure 10b shows the ratio between the number pages marked as deterministic and all the pages touched by the program. In *DM(A)*, all the pages of each benchmark are marked as deterministic while in *DM(T90)*, on average, only 51% of pages are marked as deterministic, although this caused more slowdown (up to 1.6X) as more pages are allocated in best-effort DRAM banks. These results show how the number of deterministic pages can be used as a parameter to make a trade-off between resource utilization and isolation performance.

8 Related Work

Time-predictable hardware architecture. Time-predictable hardware architecture has long been studied in the real-time community. Edwards and Lee proposed the PRET architecture, which promoted the idea of making time as a first-class citizen in computer architecture [16]. A PRET machine [38] provides hardware based isolation—featuring a thread interleaved pipeline, scratchpad memory [9] and a bank-privatized PRET DRAM controller [46]—to support strong timing predictability and repeatability. FlexPRET improves efficiency of PRET with a flexible hardware thread scheduler that guarantees hardware isolation of hard real-time threads while allowing soft real-time threads to efficiently utilize the processor pipeline [67]. T-CREST [49], MERASA [54] and parMERASA [53] projects also have investigated time-predictability focused core architecture, cache, cache coherence protocol, system-bus, and DRAM controller designs [50, 24, 48, 22, 43, 44, 34, 35]. There are also many other proposals, which focus on improving timing predictability of each individual shared hardware component—such as time predictable shared caches [61, 62, 33], hybrid SPM-cache architecture [65], and predictable DRAM controllers [60, 18, 30, 15]. In most proposals, the basic approach has been to provide space and time partitioning of hardware resources to each critical real-time task or the cores that are designated to execute such tasks. Thus, CPU-centric abstractions such as task priority and core/task id are commonly used information sources, which are utilized by these hardware proposals in managing the hardware resources. However, when it comes to managing memory related hardware resources, these CPU-centric abstractions can be too coarse-grained, which make efficient resource management difficult. This is because neither all tasks are time-critical (and thus

requires hardware isolation support), nor all memory blocks of a critical task are necessarily time-critical, as we have shown in Section 7.1.

Memory address based real-time architecture designs. The basic idea of using physical memory address in hardware-level resource management has been explored in several prior works. Kumar et al, proposed a criticality-aware cache design, which uses a number of hardware range registers to declare critical memory regions. Its Least Critical (LC) cache replacement algorithm then then prioritize the cache-lines of critical memory regions over others to ensure predictable cache performance for a single-core, fixed-priority preemptive scheduled system setup [31]. Kim et al, similarly declare critical memory regions using a set of hardware range registers to distinguish memory-criticality at the dram controller level [27]. While our approach is also based on memory address based criticality determination, our deterministic memory abstraction is designed to be utilized by the entire memory hierarchy whereas the prior works focused on a single individual hardware resource management. Furthermore, a key contribution of our approach is that, in our approach, memory criticality is determined at the page granularity by utilizing memory management unit (MMU), which enables more flexible and fine-grained (page-granularity) memory criticality control. In contrast, the prior works may be limited by the number of available hardware range registers in declaring critical memory regions. As such, our MMU-based approach is compatible with high-performance processors and general-purpose OSs such as Linux, whereas the prior works primarily focus on MMU-less processors and RTOSs. We would like to note, however, that our MMU-based deterministic memory abstraction can be integrated into and leveraged by these prior works. The deterministic memory abstraction provides a general framework for the entire memory-hierarchy and thus is complementary to the prior works.

OS-level shared resource management. In many OS-level resource management approaches, MMU has been a vital hardware component that the OS leverages for implement certain memory management policies for real-time systems. Page-coloring is a prime example that has been used to partition shared cache [36, 37, 66, 51, 14, 59, 40, 26], DRAM banks [63, 39, 52] and even TLB [42] by selecting certain physical addresses (cache color, dram bank, etc.) in allocating pages. However, in most OS-level resource management approaches, shared resources are allocated again at the granularity of task or core, which is too coarse-grained and therefore can result in resource under-utilization problems. Furthermore, these OS-level resource management approaches have fundamental limitations because they generally cannot directly influence important resource allocation and scheduling decisions done by the underlying hardware due to the lack of a generalized abstraction that allows such cross-layer communication. We address these limitations by proposing the deterministic memory abstraction, which enables close collaboration between the OS and the underlying hardware components in the memory hierarchy to achieve efficient and predictable resource allocation and scheduling. To the best of our knowledge, we are first to propose to encode each individual memory page’s time criticality in the page’s page table entry, which is then passed through the entire memory hierarchy to enable system-wide, end-to-end memory-criticality-aware resource management.

9 Conclusion and Future Work

In this paper, we proposed a new memory abstraction, which we call *Deterministic Memory*, for predictable and efficient resource management in multicore. We define deterministic memory as a special memory space that the platform—OS and hardware architecture—guarantees small and tightly bounded worst-case access timing.

We presented OS and architecture designs to efficiently support the deterministic memory abstraction. In particular, we presented a deterministic memory-aware cache design that

leverage the abstraction to improve efficiency of shared cache without losing isolation benefits of traditional way-based cache partitioning. We implemented the proposed OS extension on a real operating system (Linux) and implemented the proposed architecture extensions on a cycle-accurate full-system simulator (gem5).

Evaluation results obtained using a set of EEMBC and SD-VBS benchmarks support the potential of using the deterministic memory abstraction. Concretely, by using deterministic memory, we achieved the same degree of strong isolation while using 49% less cache space, on average, than the conventional way-based cache partitioning method.

Our immediate next plan is to implement the proposed architecture extensions on a FPGA using an open-source RISC-V core [1]. We also plan to develop methodologies and tools to identify “optimal” deterministic memory blocks that maximize the overall schedulability.

Acknowledgements

This research is supported by NSF CNS 1718880. Any opinions, findings, and conclusions or recommendations expressed in this publication are those of the authors and do not necessarily reflect the views of the NSF.

References

- [1] The berkeley out-of-order RISC-V processor code repository. <https://github.com/ucb-bar/riscv-boom>.
- [2] EEMBC benchmark suite. www.eembc.org.
- [3] Gem5: O3CPU. <http://gem5.org/O3CPU>.
- [4] Sebastian Altmeyer, Robert I Davis, and Claire Maiza. Improved cache related pre-emption delay aware response time analysis for fixed priority pre-emptive systems. *Real-Time Syst. Symp. (RTSS)*, 48(5):499–526, 2012.
- [5] ARM. *AMBA AXI and ACE Protocol Specification*, 2013.
- [6] ARM. *ARM Architecture Reference Manual. ARMv7-A and ARMv7-R Edition*, 2014.
- [7] ARM. *Cortex-A17 Technical Reference Manual, Rev: r1p1*, 2014.
- [8] N. Audsley, A. Burns, M. Richardson, K. Tindell, and A. Wellings. Applying new scheduling theory to static priority preemptive scheduling. *Software Engineering Journal*, 8(5):284–292, 1993.
- [9] R. Banakar, S. Steinke, B. Lee, M. Balakrishnan, and P. Marwedel. Scratchpad memory: design alternative for cache on-chip memory in embedded systems. In *Int. Symp. Hardware/Software Codesign (CODES+ISSS)*, pages 73–78. ACM, 2002.
- [10] N. Binkert, B. Beckmann, G. Black, S. Reinhardt, A. Saidi, A. Basu, J. Hestness, D. Hower, T. Krishna, S. Sardashti, et al. The gem5 simulator. *ACM SIGARCH Comput. Architecture News*, 2011.
- [11] Alan Burns and Robert Davis. Mixed criticality systems - A review. *Department of Computer Science, University of York, Tech. Rep*, 2013.
- [12] Certification Authorities Software Team. CAST-32A: Multi-core Processors (Rev 0). Technical report, Federal Aviation Administration (FAA), November 2016.

- [13] TIS Committee. Executable and linking format (ELF) specification version 1.2. *TIS Committee*, 1995.
- [14] X. Ding, K. Wang, and X. Zhang. SRM-buffer: an OS buffer management technique to prevent last level cache from thrashing in multicores. In *European Conf. Comput. Syst. (EuroSys)*. ACM, 2011.
- [15] Leonardo Ecco and Rolf Ernst. Improved dram timing bounds for real-time dram controllers with read/write bundling. In *Real-Time Systems Symposium (RTSS)*, pages 53–64. IEEE, 2015.
- [16] S. A. Edwards and E. A. Lee. The case for the precision timed (PRET) machine. In *Design Automation Conf. (DAC)*, 2007.
- [17] Freescale. *e500mc Core Reference Manual*, 2012.
- [18] S. Goossens, B. Akesson, and K. Goossens. Conservative open-page policy for mixed time-criticality memory controllers. In *Design, Automation and Test in Europe (DATE)*, 2013.
- [19] A. Hansson, N. Agarwal, A. Kolli, T. Wenisch, and A. Udipi. Simulating DRAM controllers for future system architecture exploration. In *Int. Symp. Performance Analysis of Syst. and Software (ISPASS)*, 2014.
- [20] J.L. Henning. SPEC CPU2006 benchmark descriptions. *ACM SIGARCH Comput. Architecture News*, 34(4):1–17, 2006.
- [21] Aamer Jaleel. Memory characterization of workloads using instrumentation-driven simulation. <http://www.jaleels.org/ajaleel/publications/SPECanalysis.pdf>, 2010.
- [22] Javier Jalle, Jaume Abella, Eduardo Quinones, Luca Fossati, Marco Zulianello, and Francisco J Cazorla. AHRB: A high-performance time-composable AMBA AHB bus. In *Real-Time and Embedded Technology and Applicat. Symp. (RTAS)*, pages 225–236. IEEE, 2014.
- [23] Javier Jalle, Eduardo Quinones, Jaume Abella, Luca Fossati, Marco Zulianello, and Francisco J Cazorla. A dual-criticality memory controller (DCmc): Proposal and evaluation of a space case study. In *Real-Time Syst. Symp. (RTSS)*, pages 207–217. IEEE, 2014.
- [24] Alexander Jordan, Florian Brandner, and Martin Schoeberl. Static analysis of worst-case stack cache behavior. In *Real-Time Networks and Systems (RTNS)*, pages 55–64. ACM, 2013.
- [25] H. Kim, D. de Niz, B. Andersson, M. Klein, O. Mutlu, and R. (Raj) Rajkumar. Bounding memory interference delay in COTS-based multi-core systems. In *Real-Time and Embedded Technology and Applicat. Symp. (RTAS)*, 2014.
- [26] H. Kim, A. Kandhalu, and R. Rajkumar. A coordinated approach for practical os-level cache management in multi-core real-time systems. In *Real-Time Syst. (ECRTS)*, pages 80–89. IEEE, 2013.
- [27] Hokeun Kim, David Bromany, Edward Lee, Michael Zimmer, Aviral Shrivastava, Junkwang Oh, et al. A predictable and command-level priority-based DRAM controller for mixed-criticality systems. In *Real-Time and Embedded Technology and Applicat. Symp. (RTAS)*, pages 317–326. IEEE, 2015.

- [28] Namhoon Kim, Bryan C Ward, Micaiah Chisholm, Cheng-Yang Fu, James H Anderson, and F Donelson Smith. Attacking the one-out-of-m multicore problem by combining hardware management with mixed-criticality provisioning. In *2016 IEEE Real-Time and Embedded Technology and Applicat. Symp. (RTAS)*, pages 1–12. IEEE, 2016.
- [29] O. Kotaba, J. Nowotsch, M. Paulitsch, S. Petters, and H Theilingx. Multicore in real-time systems temporal isolation challenges due to shared resources. In *Workshop on Industry-Driven Approaches for Cost-effective Certification of Safety-Critical, Mixed-Criticality Syst.*, 2013.
- [30] Y. Krishnapillai, Z. Wu, and R. Pellizzoni. ROC: A Rank-switching, Open-row DRAM Controller for Time-predictable Systems. In *Euromicro Conf. Real-Time Syst. (ECRTS)*, 2014.
- [31] NG Chetan Kumar, Sudhanshu Vyas, Ron K Cytron, Christopher D Gill, Joseph Zambreno, and Phillip H Jones. Cache design for mixed criticality real-time systems. In *Computer Design (ICCD)*, pages 513–516. IEEE, 2014.
- [32] Robert Leibinger. Software architectures for advanced driver assistance systems (ADAS). In *Int. Workshop on Operating Syst. Platforms for Embedded Real-Time Applicat. (OS-PERT)*, 2015.
- [33] Benjamin Lesage, Isabelle Puaut, and André Sez nec. Preti: Partitioned real-time shared cache for mixed-criticality real-time systems. In *Real-Time and Network Systems (RTNS)*, pages 171–180. ACM, 2012.
- [34] Yonghui Li, Benny Akesson, and Kees Goossens. Dynamic command scheduling for real-time memory controllers. In *Real-Time Systems (ECRTS), 2014 26th Euromicro Conference on*, pages 3–14. IEEE, 2014.
- [35] Yonghui Li, Benny Akesson, and Kees Goossens. Architecture and analysis of a dynamically-scheduled real-time memory controller. *Real-Time Systems*, pages 1–55, 2015.
- [36] J. Liedtke, H. Haertig, and M. Hohmuth. OS-Controlled cache predictability for real-time systems. In *Real-Time Technology and Applicat. Symp. (RTAS)*. IEEE, 1997.
- [37] J. Lin, Q. Lu, X. Ding, Z. Zhang, X. Zhang, and P. Sadayappan. Gaining insights into multicore cache partitioning: Bridging the gap between simulation and real systems. In *High Performance Comput. Architecture (HPCA)*. IEEE, 2008.
- [38] I. Liu, J. Reineke, D. Broman, M. Zimmer, and E. Lee. A PRET microarchitecture implementation with repeatable timing and competitive performance. In *Comput. Design (ICCD)*. IEEE, 2012.
- [39] L. Liu, Z. Cui, M. Xing, Y. Bao, M. Chen, and C. Wu. A software memory partition approach for eliminating bank-level interference in multicore systems. In *Parallel Architecture and Compilation Techniques (PACT)*, pages 367–376. ACM, 2012.
- [40] R. Mancuso, R. Dudko, E. Betti, M. Cesati, M. Caccamo, and R. Pellizzoni. Real-time cache management framework for multi-core architectures. In *Real-Time and Embedded Technology and Applicat. Symp. (RTAS)*. IEEE, 2013.
- [41] Jan Nowotsch, Michael Paulitsch, Daniel Bühler, Henrik Theiling, Simon Wegener, and Michael Schmidt. Multi-core interference-sensitive WCET analysis leveraging runtime resource capacity enforcement. In *Euromicro Conf. Real-Time Syst. (ECRTS)*, 2014.

- [42] Shrinivas Anand Panchamukhi and Frank Mueller. Providing task isolation via TLB coloring. In *Real-Time and Embedded Technology and Applicat. Symp. (RTAS)*, pages 3–13. IEEE, 2015.
- [43] M. Paolieri, E. Quiñones, F.J. Cazorla, G. Bernat, and M. Valero. Hardware support for WCET analysis of hard real-time multicore systems. In *Comput. Architecture News*. ACM, 2009.
- [44] M. Paolieri, E. Quiñones, J. Cazorla, and M. Valero. An analyzable memory controller for hard real-time CMPs. *Embedded Syst. Letters, IEEE*, 1(4):86–90, 2009.
- [45] R. Rajkumar, K. Juvva, A. Molano, and S. Oikawa. Resource kernels: A resource-centric approach to real-time and multimedia systems, January 1998.
- [46] J. Reineke, I. Liu, H.D. Patel, S. Kim, and E.A. Lee. PRET DRAM controller: Bank privatization for predictability and temporal isolation. In *Hardware/software codesign and system synthesis (CODES+ISSS)*. ACM, 2011.
- [47] S. Rixner, W. J Dally, U. J Kapasi, P. Mattson, and J. Owens. Memory access scheduling. In *ACM SIGARCH Comput. Architecture News*, volume 28, pages 128–138. ACM, 2000.
- [48] J. Rosen, A. Andrei, P. Eles, and Z. Peng. Bus access optimization for predictable implementation of real-time applications on multiprocessor systems-on-chip. In *Real-Time Syst. Symp. (RTSS)*, pages 49–60, 2007.
- [49] Martin Schoeberl, Sahar Abbaspour, Benny Akesson, Neil Audsley, Raffaele Capasso, Jamie Garside, Kees Goossens, Sven Goossens, Scott Hansen, Reinhold Heckmann, et al. T-crest: Time-predictable multi-core architecture for embedded systems. *Journal of Systems Architecture*, 61(9):449–471, 2015.
- [50] Martin Schoeberl, Pascal Schleuniger, Wolfgang Puffitsch, Florian Brandner, Christian W Probst, Sven Karlsson, Tommy Thorn, et al. Towards a time-predictable dual-issue microprocessor: The patmos approach. In *Bringing Theory to Practice: Predictability and Performance in Embedded Syst.*, volume 18, pages 11–21, 2011.
- [51] L. Soares, D. Tam, and M. Stumm. Reducing the harmful effects of last-level cache polluters with an OS-level, software-only pollute buffer. In *Int. Symp. Microarchitecture (MICRO)*. IEEE, 2008.
- [52] N. Suzuki, H. Kim, D. de Niz, B. Andersson, L. Wrage, M. Klein, and R. Rajkumar. Coordinated bank and cache coloring for temporal protection of memory accesses. In *Computational Sci. and Eng. (CSE)*, pages 685–692. IEEE, 2013.
- [53] Theo Ungerer, Christian Bradatsch, Mike Gerdes, Florian Kluge, Ralf Jahr, Jörg Mische, Joao Fernandes, Pavel G Zaykov, Zlatko Petrov, B Boddeker, S. Kehr, H. Regler, A. Hugl, C. Rochange, H. Ozaktas, H. Cass, A. Bonenfant, P. Sainrat, I. Broster, N. Lay, D. George, E. Quiones, M. Panic, J. Abella, F. Cazorla, S. Uhrig, M. Rohde, and A. Pyka. parMERASA—Multi-core Execution of Parallelised Hard Real-Time Applications Supporting Analysability. In *Digital System Design (DSD)*, pages 363–370. IEEE, 2013.
- [54] Theo Ungerer, Francisco Cazorla, Pascal Sainrat, Guillem Bernat, Zlatko Petrov, Christine Rochange, Eduardo Quinones, Mike Gerdes, Marco Paolieri, Julian Wolf, Hugues Casse, Sascha Uhrig, Irakli Guliashvili, Michael Houston, Floria Kluge, Stefan Metzloff, and Jorg Mische. Merasa: Multicore execution of hard real-time applicat. supporting analyzability. *IEEE Micro*, 30(5):66–75, 2010. doi:<http://doi.ieeecomputersociety.org/10.1109/MM.2010.78>.

- [55] P. Valsan and Heechul Yun. MEDUSA: A predictable and high-performance DRAM controller for multicore based embedded systems. In *Cyber-Physical Syst., Networks, and Applicat. (CPSNA)*. IEEE, 2015.
- [56] Prathap Kumar Valsan, Heechul Yun, and Farzad Farshchi. Taming non-blocking caches to improve isolation in multicore real-time systems. In *Real-Time and Embedded Technology and Applicat. Symp. (RTAS)*. IEEE, 2016.
- [57] Sravanthi Kota Venkata, Ikkjin Ahn, Donghwan Jeon, Anshuman Gupta, Christopher Louie, Saturnino Garcia, Serge Belongie, and Michael Bedford Taylor. SD-VBS: The San Diego vision benchmark suite. In *Int. Symp. Workload Characterization (ISWC)*, pages 55–64. IEEE, 2009.
- [58] S. Vestal. Preemptive scheduling of multi-criticality systems with varying degrees of execution time assurance. In *Real-Time Syst. Symp. (RTSS)*, pages 239–243. IEEE, 2007.
- [59] B. Ward, J. Herman, C. Kenna, and J. Anderson. Making shared caches more predictable on multicore platforms. In *Euromicro Conf. Real-Time Syst. (ECRTS)*, 2013.
- [60] Z. Wu, Y. Krish, and R. Pellizzoni. Worst case analysis of DRAM latency in multi-requestor systems. In *Real-Time Syst. Symp. (RTSS)*, 2013.
- [61] J. Yan and W. Zhang. Time-predictable L2 cache design for high-performance real-time systems. In *Embedded and Real-Time Computing Syst. and Applicat. (RTCSA)*, pages 357–366. IEEE, 2010.
- [62] Jun Yan and Wei Zhang. Time-predictable multicore cache architectures. In *Computer Research and Development (ICCRD), 2011 3rd International Conference on*, volume 3, pages 1–5. IEEE, 2011.
- [63] H. Yun, R. Mancuso, Z. Wu, and R. Pellizzoni. PALLOC: DRAM bank-aware memory allocator for performance isolation on multicore platforms. In *Real-Time and Embedded Technology and Applicat. Symp. (RTAS)*, 2014.
- [64] H. Yun and G. Yao. MemGuard: Memory bandwidth reservation system for efficient performance isolation in multi-core platforms. In *Real-Time and Embedded Technology and Applicat. Symp. (RTAS)*, 2013.
- [65] W. Zhang and Y. Ding. Hybrid spm-cache architectures to achieve high time predictability and performance. In *Application-Specific Syst., Architectures and Processors (ASAP)*, pages 297–304. IEEE, 2013.
- [66] X. Zhang, S. Dwarkadas, and K. Shen. Towards practical page coloring-based multicore cache management. In *European Conf. Comput. Syst. (EuroSys)*, 2009.
- [67] Michael Zimmer, David Broman, Chris Shaver, and Edward Lee. FlexPRET: A processor platform for mixed-criticality systems. In *Real-Time and Embedded Technology and Applicat. Symp. (RTAS)*, pages 101–110. IEEE, 2014.