

Finding Robust Solutions to Stable Marriage

Begum Genc¹, Mohamed Siala¹, Gilles Simonin², Barry O’Sullivan¹

¹ Insight, Centre for Data Analytics, Department of Computer Science, University College Cork, Ireland

² TASC, Institut Mines Telecom Atlantique, LS2N UMR 6004, Nantes, France

{begum.genc, mohamed.siala, barry.osullivan}@insight-centre.org, gilles.simonin@imt-atlantique.fr

Abstract

We study the notion of robustness in stable matching problems. We first define robustness by introducing (a,b) -supermatches. An (a,b) -supermatch is a stable matching in which if any a pairs break up it is possible to find another stable matching by changing the partners of those a pairs and the partners of at most b other pairs. In this context, we define the most robust stable matching as a $(1,b)$ -supermatch where b is minimum. We first show that checking whether a given stable matching is a $(1,b)$ -supermatch can be done in polynomial time. Next, we use this procedure to design a constraint programming model, a local search approach, and a genetic algorithm to find the most robust stable matching. Our empirical evaluation on large instances shows that local search outperforms the other approaches.

1 Introduction

Heraclitus, the Greek philosopher is quoted as saying that “Change is the only constant”. Therefore, it is essential to build robust systems that can be repaired by only minor changes in case of an unforeseen event [Sussman, 2007]. Although it is usually difficult to provide robustness to a complex problem, as it may be computationally expensive, a robust solution reduces the cost of future repairs.

This paper focuses on matching problems under preferences, where the aim is to find an assignment between two disjoint sets of agents while respecting an optimality criterion. Each agent has an ordinal preference ranking over agents of the other set. These types of problems have been widely studied by different research communities such as computer scientists and economists over the years; in fact, the 2012 Nobel Prize for Economics was awarded to Shapley and Roth for their work on stable allocations. Some of the variants can be listed as assigning residents to hospitals (HR), matching men and women to find stable marriages (SM) [Gale and Shapley, 1962; Gusfield and Irving, 1989], and finding donors for kidney patients [Roth *et al.*, 2005].

Stable Marriage (SM) [Gale and Shapley, 1962] is the first and the most studied variant of these problems. In SM, the sets of agents correspond to men and woman. The goal is to

find a matching M between men and women where each person is matched to at most one partner from the opposite sex such that there is no man and woman that prefers each other to their situations in M . Such a matching is called *stable*. We primarily work on the Stable Marriage problem, but the problem is also meaningful in the context of other matching problem variants.

We introduce the notion of (a,b) -supermatches as a measure of robustness for SM. Informally, a stable matching M is called an (a,b) -supermatch if any a agents decide to break their matches in M , thereby breaking a pairs, it is possible to “repair” M (i.e., find another stable matching) by changing the assignments of those a agents and the assignments of at most b others. This concept is inspired by the notion of (a,b) -supermodels in boolean satisfiability [Ginsberg *et al.*, 1998] and super solutions in constraint programming [Hebrard *et al.*, 2004a; Hebrard *et al.*, 2004b; Hebrard, 2007]. Note that, if one agent wants to break his/her current match, the match of the partner breaks also. Therefore, when we mention a (or b) as the number of agents, we always refer to the agents from the same set.

There exist different definitions for robustness that leads researchers to ambiguity [Climent, 2015]. We take the definitions of supermodels and super solutions as reference and use the term *robust* for characterising repairable stable matchings [Ginsberg *et al.*, 1998; Hebrard *et al.*, 2004b].

In order to give additional insight into the problem, we motivate robustness on the Hospital/Residents (HR) problem. The HR problem is a one-to-many generalization of SM. In HR, each hospital has a capacity and a preference list in which they rank the residents. Similarly, each resident has a preference list over the hospitals. A $(1,b)$ -supermatch means that if a resident wants to leave his assigned hospital or a hospital does not want to have one of its current residents, it is possible to move that resident to another hospital by also moving at most b other residents to other hospitals. By minimising b , we can ensure that the required number of additional relocations to provide a repair is minimal and therefore the solution is robust. In practice, the most robust matching minimises the cost for recovering from unwanted and unforeseen events.

The first contribution of this paper is a polynomial time procedure to verify whether a given stable matching is a $(1,b)$ -supermatch. Next, based on this procedure, we design a constraint programming (CP) model, as well as local search

(LS) and genetic algorithm (GA) to find the most robust stable matching. Last, we give empirical evidence that the local search algorithm is by far the most efficient approach to tackle this problem.

The structure of the paper is as follows: in Section 2, the basics of the Stable Marriage problem and the different notations are introduced. In Section 3, our polynomial-time method is proposed. Next, we give the CP model in Section 4 and the two meta-heuristic algorithms in Section 5. Finally, we give our experimental study in Section 6.

2 Stable Marriage

The Stable Marriage problem takes as input a set of men $U = \{m_1, m_2, \dots, m_{n_1}\}$ and a set of woman $W = \{w_1, w_2, \dots, w_{n_2}\}$ where each person has an ordinal preference list over people of the opposite sex. For the sake of simplicity we suppose in the rest of the paper that $n_1 = n_2$ (denoted by n), and that each person expresses a complete preference ranking over the set of opposite sex. In the rest of the paper we interchangeably use i to denote man m_i in U or similarly j to denote woman w_j in W .

A *matching* M is a one-to-one correspondence between U and W . For each man m_i , $M(m_i) = w_j$ is called the partner of m_i in matching M . In the latter case, we denote by $M(w_j) = m_i$. We shall sometimes abuse notation by considering M as a set of pairs. In that case, a pair $\langle m_i, w_j \rangle \in M$ iff $M(m_i) = w_j$. A pair $\langle m_i, w_j \rangle$ is said to be *blocking* a matching M if m_i prefers w_j to $M(m_i)$ and w_j prefers m_i to $M(w_j)$. A *matching* M is called *stable* if there exists no blocking pairs for M . A pair $\langle m_i, w_j \rangle$ is said to be *stable* if it appears in a stable matching. Also, a pair $\langle m_i, w_j \rangle$ is *fixed* if $\langle m_i, w_j \rangle$ appears in every stable matching.

The structure that represents all stable matchings forms a *lattice* \mathcal{M} . In this lattice, the man-optimal matching is denoted by M_0 and the woman-optimal (man-pessimal) matching is denoted by M_z . A stable matching M_i *dominates* a stable matching M_j , denoted by $M_i \preceq M_j$, if every man prefer their matches in M_i to M_j or indifferent between them. The size of a lattice can be exponential as the number of all stable matchings can be exponential [Irving and Leather, 1986]. Therefore, making use of this structure for measuring the robustness of a stable matching is not practical.

Table 1 gives an example of a Stable Marriage instance with 7 men/women. For the sake of clarity, we denote each man m_i with i and each woman w_j with j .

m_0	0 6 5 2 4 1 3	w_0	2 1 6 4 5 3 0
m_1	6 1 4 5 0 2 3	w_1	0 4 3 5 2 6 1
m_2	6 0 3 1 5 4 2	w_2	2 5 0 4 3 1 6
m_3	3 2 0 1 4 6 5	w_3	6 1 2 3 4 0 5
m_4	1 2 0 3 4 5 6	w_4	4 6 0 5 3 1 2
m_5	6 1 0 3 5 4 2	w_5	3 1 2 6 5 4 0
m_6	2 5 0 6 4 3 1	w_6	4 6 2 1 3 0 5

Table 1: Preference lists for men (left) and women (right) for a sample Stable Marriage instance of size 7.

Let M be a stable matching. A *rotation* $\rho = (\langle m_{i_0}, w_{j_0} \rangle, \langle m_{i_1}, w_{j_1} \rangle, \dots, \langle m_{i_{l-1}}, w_{j_{l-1}} \rangle)$ (where $l \in \mathbb{N}^*$)

is an ordered list of pairs in M such that changing the partner of each man m_{i_c} to the partner of the next man $m_{i_{c+1}}$, where $0 \leq c \leq l-1$ and the operation $+1$ is modulo l , in the list ρ leads to a stable matching M/ρ . The latter is said to be obtained after *eliminating* ρ from M . In this case, we say that $\langle m_{i_c}, w_{i_c} \rangle$ is eliminated by ρ , $\langle m_{i_c}, w_{i_{c+1}} \rangle$ is produced by ρ , and that ρ is *exposed* in M .

For each pair $\langle m_i, w_j \rangle \in \rho$, we say m_i (or w_j) is *involved* in ρ . Additionally, for each $\langle m_i, w_j \rangle$ such that $\langle m_i, w_j \rangle \notin M_0$, there exists a unique rotation $\rho_{p_{i,j}}$ that produces $\langle m_i, w_j \rangle$. Similarly, if $\langle m_i, w_j \rangle \notin M_z$ there is a unique rotation $\rho_{e_{i,j}}$ that eliminates $\langle m_i, w_j \rangle$. Note that it is always the case that M (strictly) dominates M/ρ .

There exists a partial order for rotations. A rotation ρ' is said to precede another rotation ρ (denoted by $\rho' \prec \rho$), if ρ' is eliminated in every sequence of eliminations that starts at M_0 and ends at a stable matching in which ρ is exposed [Gusfield and Irving, 1989]. Note that this relation is transitive, that is, $\rho'' \prec \rho' \wedge \rho' \prec \rho \implies \rho'' \prec \rho$. Two rotations are said to be *incomparable* if one does not precede the other. The structure that represents all rotations and their partial order is a directed graph called *rotation poset* denoted by $\Pi = (\mathcal{V}, E)$. Each rotation corresponds to a vertex in \mathcal{V} and there exists an edge from ρ' to ρ if ρ' precedes ρ . The number of rotations is bounded by $n(n-1)/2$ and the number of arcs is $O(n^2)$ [Gusfield and Irving, 1989]. It should be noted that the construction of Π can be done in $O(n^2)$.

Predecessors of a rotation ρ in a rotation poset are denoted by $N^-(\rho)$ and successors are denoted by $N^+(\rho)$. Later, we shall not need transitivity to complete these lists. Therefore, we denote by $N_t^-(\rho)$ (respectively $N_t^+(\rho)$) the predecessors (respectively successors) of a rotation ρ including transitivity.

In Figure 1, we give the lattice of all stable matchings of the instance given in Table 1. There exists two vectors for each stable matching. The first vector represents the set of men and the second vector represents the partner of each man in the matching. Each edge of the form M to M' on the lattice is labeled with the rotation ρ such that M' is obtained after exposing ρ on M . All the rotations are given in Figure 2. The latter represents the rotation poset of this instance.

A *closed subset* S is a set of rotations such that for any rotation ρ in S , if there exists a rotation $\rho' \in \mathcal{V}$ that precedes ρ then ρ' is also in S . By Theorem 1, every closed subset in the rotation poset corresponds to a stable matching. We denote by $X(S)$ the set of men that are included in at least one of the rotations in S .

Below is a theorem and a corollary from [Gusfield and Irving, 1989] mainly used in some proofs in the next section.

Theorem 1 (Theorem 2.5.7). *i) There is a one-one correspondence between the closed subsets of Π and the stable matchings of \mathcal{M} .*

ii) S is the closed subset of rotations of Π corresponding to a stable matching M if and only if S is the (unique) set of rotations on every M_0 -chain in \mathcal{M} ending at M . Further, M can be generated from M_0 by eliminating the rotations in their order along any of these paths, and these are the only ways to generate M by rotation eliminations starting from M_0 .

iii) If S and S' are the unique sets of rotations corresponding

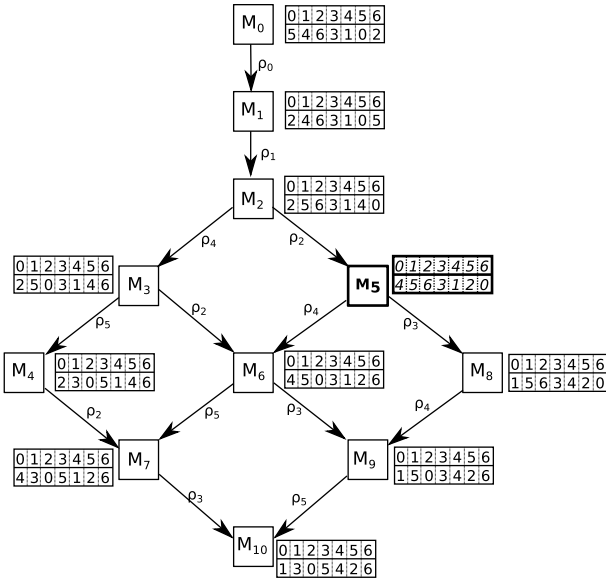

Figure 1: The lattice of all stable matchings corresponding to the instance given in Table 1.

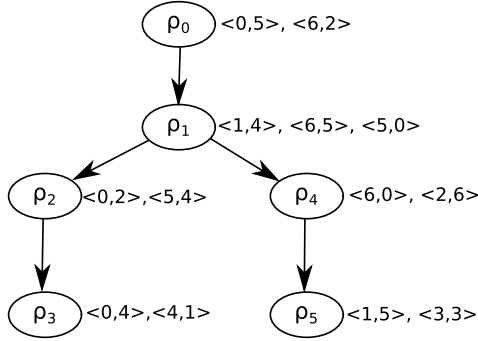

Figure 2: Rotation poset of the instance given in Table 1.

to distinct stable matchings M and M' , then M dominates M' if and only if $S \subset S'$.

Corollary 1 (Corollary 3.2.1). *Every man-woman pair $\langle m, w \rangle$ is in at most one rotation. Hence there are at most $n(n-1)/2$ rotations in an instance of the Stable Marriage problem of size n .*

We introduce here a notion that is important to measure robustness. Let M_i and M_j be two stable matchings. The distance $d(M_i, M_j)$ is the number of men that have different partners in M_i and M_j . A matching M_i is closer to M_j than M_k if $d(M_i, M_j) < d(M_i, M_k)$. We give in Definition 1 a formal definition of (a, b) -supermatch.

Definition 1. *(a, b) -supermatch A stable matching M is said to be (a, b) -supermatch if for any set $\Psi \subset M$ of a stable pairs that are not fixed, there exists a stable matching M' such that $M' \cap \Psi = \emptyset$ and $d(M, M') - a \leq b$.*

In this paper, we focus on the $(1, b)$ -supermatch case. Notice that for any stable matching M , there exists a value b such that M is a $(1, b)$ -supermatch. In this case, we say that b is

the *robustness value* of M . The *most robust stable matching* is a $(1, b)$ -supermatch with the minimum robustness value.

3 Checking $(1, b)$ -supermatch in Polynomial Time

A preliminary version of this section appeared in [Genc *et al.*, 2017].

In this section, we first recall the basics, and then show how to find or verify the closest stable matching of a given stable matching with an unwanted couple. Throughout this section, we suppose that M is a given stable matching, S its corresponding closed subset, and $\langle m_i, w_j \rangle \in M$ is a non-fixed (stable) pair to remove from M .

The closest stable matching to M that does not include $\langle m_i, w_j \rangle$ is a matching M^* in which either $\langle m_i, w_j \rangle$ was eliminated or not produced in any sequence of rotation eliminations starting from M_0 leading to M^* . Hence, if $\langle m_i, w_j \rangle \notin M_0$ then $\rho_{p_{i,j}}$ exists, and there is a set of stable matchings S_u , where each of them dominates M and does not include the $\langle m_i, w_j \rangle$. Similarly, if $\langle m_i, w_j \rangle \notin M_z$ then $\rho_{e_{i,j}}$ exists, and there is a set of stable matchings S_d , where each of them is dominated by M and does not include the pair $\langle m_i, w_j \rangle$.

If $\langle m_i, w_j \rangle \notin M_0$, we define a specific set of rotations S_{UP}^{*i} as follows¹:

$$S_{UP}^{*i} = S \setminus (\{\rho_{p_{i,j}}\} \cup (N_t^+(\rho_{p_{i,j}}) \cap S)). \quad (1)$$

If $\langle m_i, w_j \rangle \notin M_z$, we define a specific set of rotations S_{DOWN}^{*i} as follows:

$$S_{DOWN}^{*i} = S \cup \{\rho_{e_{i,j}}\} \cup (N_t^-(\rho_{e_{i,j}}) \setminus S). \quad (2)$$

Observe first that S_{UP}^{*i} and S_{DOWN}^{*i} are in fact closed subsets since S is a closed subset. Let M_{UP}^{*i} (respectively M_{DOWN}^{*i}) be the stable matching corresponding to S_{UP}^{*i} (respectively S_{DOWN}^{*i}). By construction, we have $M_{UP}^{*i} \in S_u$ and $M_{DOWN}^{*i} \in S_d$. We show later that any stable matching $M_k \notin \{M_{UP}^{*i}, M_{DOWN}^{*i}\}$ that does not include the pair $\langle m_i, w_j \rangle$ cannot be closer to M than M_{UP}^{*i} or M_{DOWN}^{*i} .

For illustration, consider the stable matching M_5 of the previous example and its closed subset $S_5 = \{\rho_0, \rho_1, \rho_2\}$. Table 2 shows for each pair $\langle m_i, w_j \rangle$ the matchings S_{UP}^{*i} and S_{DOWN}^{*i} if they exist.

$\langle m_i, w_j \rangle$	$\rho_{p_{i,j}}$	$\rho_{e_{i,j}}$	S_{UP}^{*i}	S_{DOWN}^{*i}
$\langle m_0, w_4 \rangle$	ρ_2	ρ_3	$\{\rho_0, \rho_1\}$	$\{\rho_0, \rho_1, \rho_2, \rho_3\}$
$\langle m_1, w_5 \rangle$	ρ_1	ρ_5	$\{\rho_0\}$	$\{\rho_0, \rho_1, \rho_2, \rho_4, \rho_5\}$
$\langle m_2, w_6 \rangle$	-	ρ_4	-	$\{\rho_0, \rho_1, \rho_2, \rho_4\}$
$\langle m_3, w_3 \rangle$	-	ρ_5	-	$\{\rho_0, \rho_1, \rho_2, \rho_4, \rho_5\}$
$\langle m_4, w_1 \rangle$	-	ρ_3	-	$\{\rho_0, \rho_1, \rho_2, \rho_3\}$
$\langle m_5, w_2 \rangle$	ρ_2	-	$\{\rho_0, \rho_1\}$	-
$\langle m_6, w_0 \rangle$	ρ_1	ρ_4	$\{\rho_0\}$	$\{\rho_0, \rho_1, \rho_2, \rho_4\}$

Table 2: The repair closed subsets S_{UP}^{*i} and S_{DOWN}^{*i} for M_5 .

¹The brackets $()$ in Equations 1 and 2 are used to give the priority between the operators.

Table 3 shows the stable matchings corresponding to the closed subsets given in Table 2 and the distances between the current stable matching M_5 to each one of them. The distances are denoted as d_{up}^i and d_{down}^i in the table, where for each man m_i , $d_{up}^i = d(M_5, M_{UP}^{*i})$ and $d_{down}^i = d(M_5, M_{DOWN}^{*i})$, respectively. If M_{UP}^{*i} does not exist for a man m_i , then d_{up}^i is denoted by ∞ (the same value is used when M_{DOWN}^{*i} does not exist). Last, $b_i = \min(d_{up}^i, d_{down}^i) - 1$ represents the repair cost of each man. The reason for extraction of 1 is because we are considering only $(1, b)$ -supermatches (see Definition 1).

M_{UP}^{*i}	M_{DOWN}^{*i}	d_{up}^i	d_{down}^i	b_i
M_2	M_8	2	2	1
M_1	M_7	4	4	3
-	M_6	∞	2	1
-	M_7	∞	4	3
-	M_8	∞	2	1
M_2	-	2	∞	1
M_1	M_6	4	2	1

Table 3: The repair stable matchings M_{UP}^{*i} and M_{DOWN}^{*i} for each man in M_5 and the distances between the original stable matching and the repair stable matchings.

The robustness of a stable matching is equal to the repair cost of the non-fixed man that has the worst repair cost $b = \sum_{i \in \{1..n\}} \max(b_i)$. For the follow-up example, M_5 is labelled as a $(1, 3)$ -supermatch. Moreover, Table 4 shows the $(1, b)$ -robustness measures for each stable matching of the given sample. The most robust stable matching for the sample is identified as M_6 since it has the smallest b value.

SM (M_k)	Closed Subset (S_k)	Robustness (b)
M_0	$\{\}$	5
M_1	$\{\rho_0\}$	4
M_2	$\{\rho_0, \rho_1\}$	3
M_3	$\{\rho_0, \rho_1, \rho_4\}$	2
M_4	$\{\rho_0, \rho_1, \rho_4, \rho_5\}$	3
M_5	$\{\rho_0, \rho_1, \rho_2\}$	3
M_6	$\{\rho_0, \rho_1, \rho_2, \rho_4\}$	1
M_7	$\{\rho_0, \rho_1, \rho_2, \rho_4, \rho_5\}$	3
M_8	$\{\rho_0, \rho_1, \rho_2, \rho_3\}$	3
M_9	$\{\rho_0, \rho_1, \rho_2, \rho_3, \rho_4\}$	2
M_{10}	$\{\rho_0, \rho_1, \rho_2, \rho_3, \rho_4, \rho_5\}$	3

Table 4: The robustness values of all stable matchings for the sample given in Table 1.

We give few lemmas in order to show that the closest stable matching to M when breaking the pair $\langle m_i, w_j \rangle$ is either S_{UP}^{*i} or S_{DOWN}^{*i} .

Lemma 1. *Given two incomparable rotations ρ and ρ' , $X(\{\rho\}) \cap X(\{\rho'\}) = \emptyset$.*

Proof. By definition of incomparability, if two rotations are incomparable, it means that they modify a set of men who do

not require modifications from the other first. Therefore the sets of men are distinct. \square

Lemma 2. *Given three stable matchings M_x, M_y and M_z such that $M_x \preceq M_y \preceq M_z$, then $d(M_y, M_z) \leq d(M_x, M_z)$ and $d(M_x, M_y) \leq d(M_x, M_z)$.*

Proof. Using the properties of domination and the closed subsets in Theorem 1, we can infer $S_x \subset S_y \subset S_z$.

Assume to the contrary that $d(M_y, M_z) > d(M_x, M_z)$. This situation occurs only if a set of pairs that are present in M_x are eliminated to obtain M_y and then re-matched with the same partners they had in M_x to get M_z . However, this contradicts Corollary 1. For similar reasons, $d(M_x, M_y) < d(M_x, M_z)$. \square

The case where stable matchings have the same distance such as $d(M_x, M_y) = d(M_x, M_z)$, if the rotation set in the difference sets $S_y \setminus S_x$, $S_z \setminus S_x$, and $S_z \setminus S_y$ modify the same set of men. We can demonstrate the case where we have equal distance between the three matchings on a Stable Marriage instance of size 8 given in Manlove's book on page 91 [Manlove, 2013]. It can be verified that $M_8 \preceq M_{15} \preceq M_{21}$, where:

$$M_8 = \{\langle 1, 1 \rangle, \langle 2, 3 \rangle, \langle 3, 4 \rangle, \langle 4, 8 \rangle, \langle 5, 2 \rangle, \langle 6, 5 \rangle, \langle 7, 6 \rangle, \langle 8, 7 \rangle\},$$

$$M_{15} = \{\langle 1, 5 \rangle, \langle 2, 4 \rangle, \langle 3, 3 \rangle, \langle 4, 6 \rangle, \langle 5, 8 \rangle, \langle 6, 7 \rangle, \langle 7, 2 \rangle, \langle 8, 1 \rangle\},$$

$$M_{21} = \{\langle 1, 7 \rangle, \langle 2, 8 \rangle, \langle 3, 2 \rangle, \langle 4, 1 \rangle, \langle 5, 6 \rangle, \langle 6, 4 \rangle, \langle 7, 3 \rangle, \langle 8, 5 \rangle\}.$$

In this case, due to the fact that $X(S_{15} \setminus S_8) = X(S_{21} \setminus S_{15}) = X(S_{21} \setminus S_8)$, the distances of all three matchings will be equal to each other $d(M_8, M_{15}) = d(M_{15}, M_{21}) = d(M_8, M_{21}) = 8$.

Lemma 3. *If there exists a stable matching M_x that does not contain $\langle m_i, w_j \rangle$, dominates M and different from M_{UP}^{*i} , then M_x dominates M_{UP}^{*i} .*

Proof. $M_{UP}^{*i} \preceq M$ by definition. Suppose by contradiction that there exists an M_x such that $\langle m_i, w_j \rangle \notin M_x$ and $M_{UP}^{*i} \preceq M_x \preceq M$. It implies that $S_{UP}^{*i} \subset S_x \subset S$. In this case, $(S_x \setminus S_{UP}^{*i}) \subset \{\{\rho_{p_{i,j}}\} \cup \{N_t^+(\rho_{p_{i,j}}) \cap S\}\}$. However, this set contains $\rho_{p_{i,j}}$ and the rotations preceded by $\rho_{p_{i,j}}$. Adding any rotation from this set to S_x results in a contradiction by either adding $\langle m_i, w_j \rangle$ to the matching, thereby not breaking that couple, or because the resulting set is not a closed subset. \square

Lemma 4. *If there exists an M_x that does not contain $\langle m_i, w_j \rangle$ dominated by M but different from M_{DOWN}^{*i} , then M_{DOWN}^{*i} dominates M_x .*

Proof. Similar to the proof above, suppose that there exists an M_x such that $\langle m_i, w_j \rangle \notin M_x$ and $M \preceq M_x \preceq M_{DOWN}^{*i}$. We have $S \subset S_x \subset S_{DOWN}^{*i}$. It implies $(S_x \setminus S) \subset \{\{\rho_{e_{i,j}}\} \cup \{N_t^-(\rho_{e_{i,j}}) \setminus S\}\}$. This set contains the rotation $\rho_{e_{i,j}}$ that eliminates the pair and the rotations preceding $\rho_{e_{i,j}}$. In order to add $\rho_{e_{i,j}}$ all other rotations must be added to form a closed subset. If all rotations are added, $S = S_{DOWN}^{*i}$ which results in a contradiction. \square

Lemma 5. For any stable matching M_k incomparable with M such that M_k does not contain the pair $\langle m_i, w_j \rangle$, M_{UP}^{*i} is closer to M than M_k .

Proof. Let S_k be the closed subset corresponding to M_k , and S be that corresponding to M .

First, we consider the case in which $S_k \cap S = \emptyset$. If the closed subsets have no rotations in common the rotations in these sets are incomparable. Using Lemma 1, $X(S_k) \cap X(S) = \emptyset$. Therefore, $d(M_k, M) = |X(S_k)| + |X(S)|$, whereas $d(M_{\text{UP}}^{*i}, M) \leq |X(S)|$.

Second, we consider the case in which $S_k \cap S \neq \emptyset$. Let M_c be the closest dominating stable matching of both M_k and M_{UP}^{*i} , along with S_c as its corresponding closed subset. Using Lemma 2 we know that $d(M_{\text{UP}}^{*i}, M) \leq d(M_c, M)$, where $d(M_c, M) = |X(S \setminus S_c)|$.

Using Lemma 1 we know that $X(S_k \setminus S_c) \cap X(S \setminus S_c) = \emptyset$. Therefore, $d(M_k, M) = |X(S_k \setminus S_c)| + |X(S \setminus S_c)|$. By substituting the formula above, $d(M_k, M) \geq |X(S_k \setminus S_c)| + d(M_{\text{UP}}^{*i}, M)$. Using the fact that $|X(S_k \setminus S_c)| > 0$ from the definition of M_k , we can conclude that $d(M_k, M) > d(M_{\text{UP}}^{*i}, M)$. \square

The following theorem is a direct consequence of Lemmas 3, 4, 5.

Theorem 2. The closest stable matching of a stable matching M given the unwanted pair $\langle m_i, w_j \rangle$ is either M_{UP}^{*i} or M_{DOWN}^{*i} .

We show that checking if a stable matching is a $(1, b)$ -supermatch can be performed in $O(n \times |\mathcal{V}|)$ time after a $O(n^2 + |\mathcal{V}|^2)$ preprocessing step. First, the pre-processing step consists of building: the poset graph (in $O(n^2)$ time); the lists $N_t^-(\rho)$, $N_t^+(\rho)$ for each rotation ρ (in $O(|\mathcal{V}|^2)$ time); and $\rho_{e_{i,j}}$ and $\rho_{p_{i,j}}$ for each pair $\langle m_i, w_j \rangle$ whenever applicable (in $O(n^2)$ time). Next, we compute S_{UP}^{*i} and S_{DOWN}^{*i} for each man. Note that S_{UP}^{*i} and S_{DOWN}^{*i} can be constructed in $O(|\mathcal{V}|)$ time (by definition of S_{UP}^{*i} and S_{DOWN}^{*i}) for each man m_i . Note that $d(M_{\text{UP}}^{*i}, M)$ is equal to the number of men participating in the rotations that are eliminated from S to obtain S_{UP}^{*i} . Similarly, $d(M_{\text{DOWN}}^{*i}, M)$ is equal to the number of men participating in the rotations that are added to S to obtain S_{DOWN}^{*i} . Last, if $b < d(M_{\text{UP}}^{*i}, M) - 1$ and $b < d(M_{\text{DOWN}}^{*i}, M) - 1$, we know that it is impossible to repair M when m_i needs to change his partner with at most b other changes. Otherwise, M is a $(1, b)$ -supermatch.

The constraint programming (CP) formulation and the metaheuristic approaches that we propose in the following sections to find the most robust stable matching are essentially based on this procedure.

4 A Constraint Programming Formulation

Constraint programming (CP) is a powerful technique for solving combinatorial search problems by expressing the relations between decision variables as constraints [Rossi *et al.*, 2006]. We give in this section a CP formulation for finding the most robust stable matching, that is, the $(1, b)$ -supermatch with the minimum b . The idea is to formulate the stable

matching problem using rotations, then extend that formulation in order to compute the two values $d(M_{\text{UP}}^{*i}, M)$ and $d(M_{\text{DOWN}}^{*i}, M)$ (where M is the solution) for each man m_i so that b is always greater or equal to one of them. Using rotations to model stable matching problems has been used in [Gusfield and Irving, 1989] (page 194), and in [Feder, 1992; Fleiner *et al.*, 2007; Siala and O’Sullivan, 2017].

Let SP be the set of all stable pairs that are not fixed and NM be the set of all men that are at least in one of the pairs in SP . Let the set of rotations be $\{\rho_1, \rho_2, \dots, \rho_{|\mathcal{V}|}\}$ and for each $\langle m_i, w_j \rangle \notin M_0$, $\rho_{p_{i,j}}$ is the unique rotation that produces $\langle m_i, w_j \rangle$. Moreover, for each $\langle m_i, w_j \rangle \notin M_z$, $\rho_{e_{i,j}}$ denotes the unique rotation that eliminates the pair $\langle m_i, w_j \rangle$. Notice that $p_{i,j}, e_{i,j} \in \{1, \dots, |\mathcal{V}|\}$. We use R_i to denote the set of rotations in which man m_i is involved.

In our model, we assume that a $O(n^2)$ pre-processing step is performed to compute M_0, M_z, SP, NM , the poset graph, $\rho_{e_{i,j}}$, and $\rho_{p_{i,j}}$ for every pair $\langle m_i, w_j \rangle$ whenever applicable. We also need to compute the lists $N_t^-(\rho)$, $N_t^+(\rho)$ for each rotation ρ (in $O(|\mathcal{V}|^2)$ time).

We start by giving the different sets of variables, then we show the constraints. Let w_i^0 denote man m_i ’s partner in M_0 , and w_i^z denote his partner in M_z . There exists a boolean variable $x_{i,j}$ for every pair $\langle m_i, w_j \rangle$ to indicate if $\langle m_i, w_j \rangle$ is part of the solution M . Therefore, $x_{i,j}$ is a boolean variable related to a pair in SP . There exists also a boolean variable s_v for each rotation ρ_v , where $v \in \{1, \dots, |\mathcal{V}|\}$ to indicate if ρ_v is in the closed subset of the solution. Moreover, we use an integer variable b with $[1, |NM| - 1]$ as an initial domain to represent the objective. That is, the solution is a $(1, b)$ -supermatch with the minimum b .

For each man $m_i \in NM$, we define the following variables:

- α_i (respectively β_i): a boolean variable to indicate if $\langle m_i, w_{w_i^0} \rangle$ (respectively $\langle m_i, w_{w_i^z} \rangle$) is a part of the solution.
- $s_{up_v}^i$ (respectively $s_{down_v}^i$): a boolean variable for every $\rho_v \in \mathcal{V}$ to know if ρ_v is in the difference set $S \setminus S_{\text{UP}}^{*i}$ (respectively $S_{\text{DOWN}}^{*i} \setminus S$) where S is the closed subset of the solution, S_{UP}^{*i} (respectively S_{DOWN}^{*i}) corresponds to the closed subset of the nearest stable matchings dominating (respectively dominated by) S when then pair defined by man m_i and his partner is to be eliminated.
- y_l^i (respectively z_l^i): a boolean variable for each man $m_l \in NM$ to know if the partner of m_l needs to be changed to find a repair when man m_i breaks up with his partner to obtain S_{UP}^{*i} (respectively S_{DOWN}^{*i}) from the solution.

A pair is a part of a solution if and only if it is produced by a rotation (if it is not a part of M_0) and not eliminated by another (if it is not a part of M_z). Moreover, a set of rotations corresponds to a closed subset (or a solution) if and only if all the parents of each rotation in the set are also in the set. Hence, the following constraints are required to keep track of the pairs that are in the solutions and also to make sure the solution is a stable matching.

More specifically, let S denote the closed subset of the solution. Without loss of generality, the first constraints ensure that if a pair $\langle m_i, w_j \rangle$ is in the solution, the rotation that produces $\langle m_i, w_j \rangle$ must be in S and the rotation that eliminates it should not be in S . The second constraints enforce the set of rotations assigned to true to form a closed subset. This model was used in the many-to-many setting in [Siala and O’Sullivan, 2017].

1. $\forall \langle m_i, w_j \rangle \in SP$:
 - (a) If $\langle m_i, w_j \rangle \in M_0, x_{i,j} \leftrightarrow \neg s_{e_{i,j}}$
 - (b) Else if $\langle m_i, w_j \rangle \in M_z, x_{i,j} \leftrightarrow s_{p_{i,j}}$
 - (c) Otherwise $x_{i,j} \leftrightarrow (s_{p_{i,j}} \wedge \neg s_{e_{i,j}})$
2. $\forall \rho_v, \forall \rho_{v'} \in N^-(\rho_v): s_v \rightarrow s_{v'}$.
3. The following set of constraints are required to build the difference set $S \setminus S_{UP}^{*i}$:
 - (a) $\forall m_i \in NM, \alpha_i \leftrightarrow x_{i,w_i^0}$: This constraint handles the special case when man m_i is matched to his partner in M_0 .
 - (b) $\forall m_i \in NM$:
 - i. $\forall \langle m_i, w_j \rangle \in SP$, where $j \neq w_i^0$: $x_{i,j} \leftrightarrow s_{sup_{p_{i,j}}^i}$.
This constraint is used to know the rotation that produces the partner of m_i in the solution.
 - ii. $\forall \rho_v \in \mathcal{V}$:
 - $\alpha_i \rightarrow \neg s_{up_{\rho_v}^i} \forall \rho_v \in \mathcal{V}$: to make sure if this pair is not produced by a rotation, then there does not exist an S_{UP}^{*i} set.
 - $s_{up_{\rho_v}^i} \wedge s_{v'} \rightarrow s_{up_{\rho_{v'}}^i}, \forall \rho_{v'} \in N^+(\rho_v)$: to build the difference set.
 - There are two cases to distinguish:
 - If ρ_v produces the pair $\langle m_i, w_j \rangle$: $s_{up_{\rho_v}^i} \rightarrow s_v \wedge (x_{i,j} \vee \bigvee_{\rho_{v*} \in N^-(\rho_v)} (s_{up_{\rho_{v*}}^i}))$.
 - Else: $s_{up_{\rho_v}^i} \rightarrow s_v \wedge (\bigvee_{\rho_{v*} \in N^-(\rho_v)} (s_{up_{\rho_{v*}}^i}))$.
4. Following the same intuition above, we use the following constraints to represent the difference set $S_{DOWN}^{*i} \setminus S$.
 - (a) $\forall m_i \in NM, \beta_i \leftrightarrow x_{i,w_i^Z}$.
 - (b) $\forall m_i \in NM$:
 - i. $\forall \langle m_i, w_j \rangle \in SP$, where $j \neq w_i^Z$: $x_{i,j} \leftrightarrow s_{down_{e_{i,j}}^i}$
 - ii. $\forall \rho_v \in \mathcal{V}$:
 - $\beta_i \rightarrow \neg s_{down_{\rho_v}^i}$: to handle the particular case of having a partner in M_z .
 - $s_{down_{\rho_v}^i} \wedge \neg s_{v'} \rightarrow s_{down_{\rho_{v'}}^i}, \forall \rho_{v'} \in N^-(\rho_v)$.
 - There are two cases to distinguish:
 - If ρ_v eliminates the pair $\langle m_i, w_j \rangle$: $s_{down_{\rho_v}^i} \rightarrow \neg s_v \wedge (x_{i,j} \vee \bigvee_{\rho_{v*} \in N^+(\rho_v)} s_{down_{\rho_{v*}}^i})$.
 - Else: $s_{down_{\rho_v}^i} \rightarrow \neg s_v \wedge (\bigvee_{\rho_{v*} \in N^+(\rho_v)} s_{down_{\rho_{v*}}^i})$.
5. Last, we define the following constraints to count exactly how many men must be modified to repair the solution by using S_{UP}^{*i} and S_{DOWN}^{*i} :

- (a) The following two constraints are required to keep track if man m_l has to change his partner to obtain S_{UP}^{*i} (or S_{DOWN}^{*i}) upon the break-up of man m_i with his current partner. $\forall m_l \neq m_i \in NM$:
 - i. $y_l^i \leftrightarrow \bigvee_{\rho_v \in R_l} s_{up_{\rho_v}^i}$
 - ii. $z_l^i \leftrightarrow \bigvee_{\rho_v \in R_l} s_{down_{\rho_v}^i}$
- (b) The next two constraints are required to count the number of men that needs to change their partners to obtain the closest stable matchings. $\forall m_i \in NM$:
 - i. $\alpha_i \rightarrow d_{up}^i = n$ and $\neg \alpha_i \rightarrow d_{up}^i = \sum y_l^i$
 - ii. $\beta_i \rightarrow d_{down}^i = n$ and $\neg \beta_i \rightarrow d_{down}^i = \sum z_l^i$
- (c) To constrain b:

$$\forall m_i \in NM, (\neg \alpha_i \rightarrow (b \geq d_{up}^i)) \vee (\neg \beta_i \rightarrow (b \geq d_{down}^i))$$
- (d) The objective is to minimise b . We can easily improve the initial upper bound by taking the minimum value between the maximum number of men required to repair any (non-fixed) pair from M_0 and from M_z .

5 Metaheuristics

For finding the $(1, b)$ -supermatch with minimal b , we provide solutions using two different mono-objective metaheuristics: genetic algorithm (GA) and iterated local search (LS) [Boussaïd *et al.*, 2013]. The intuition behind using those approaches is that they are mostly based on finding neighbour solutions and are easy to adapt to our problem. In this section, we will describe how to apply those two methods to find $(1, b)$ -supermatches and subsequently the most robust stable matching.

The two metaheuristic models described in the following sections are also based on the assumption that a $O(n^2)$ pre-processing step is performed to compute M_0, M_z , the poset graph, the lists $N_t^-(\rho), N_t^+(\rho)$ for each rotation ρ (in $O(|\mathcal{V}|^2)$ time).

5.1 Genetic Algorithm

Genetic algorithms are being used extensively in optimization problems as an alternative to traditional heuristics. They are compelling robust search and optimization tools, which work on the natural concept of evolution, based on natural genetics and natural selection. Holland introduced the GAs and he has also shown how to apply the process to various computationally difficult problems [Holland, 1975; Holland, 1992; Bäck, 1996].

Our approach is based on the traditional GA, where evolutions are realised after the initialisation of a random set of solutions (population). The process finishes either when an acceptable solution is found or the search loop reaches a pre-determined limit, i.e. maximum iteration count or time limit.

The genetic algorithm that we propose to find the most robust stable matching is detailed below with a follow-up example for one iteration.

Initialization

The purpose of initialization step is to generate a number of random stable matchings for constructing the initial population set, denoted by \mathbf{P} . Recall that each closed subset in the rotation poset corresponds to a stable matching. The random stable matching generation is performed by selecting a random rotation ρ from the rotation poset and adding all of its predecessors to the rotation set to construct a closed subset S , therefore a stable matching M as detailed in Algorithm 1. In Line 6, the method $\text{CREATESM}(S)$ is responsible from converting the given closed subset S to its corresponding matching M by exposing all the rotations in S in order on M_0 .

Algorithm 1 Random Stable Matching Creation

```

1: procedure CREATERANDOMSM()
2:    $\rho \leftarrow \text{SELETRANDOM}(\mathcal{V})$ 
3:    $S \leftarrow \{\rho\}$ 
4:   for  $\rho_p \in \text{ALLPREDECESSORS}(\rho)$  do
5:      $S \leftarrow S \cup \{\rho_p\}$ 
6:    $M \leftarrow \text{CREATESM}(S)$ 
   return  $M$ 

```

Then, n randomly created stable matchings are added to the population set \mathbf{P} as described in Algorithm 2.

Algorithm 2 Initialization of the Population

```

1: procedure INITIALIZE( $n$ )
2:    $\mathbf{P} \leftarrow \emptyset$ 
3:    $i \leftarrow 0$ 
4:   while  $i < n$  do
5:      $M_i \leftarrow \text{CREATERANDOMSM}()$ 
6:      $\mathbf{P} \leftarrow \mathbf{P} \cup \{M_i\}$ 
7:      $i \leftarrow i + 1$ 
   return  $\mathbf{P}$ 

```

Let us illustrate the procedure on a sample for the Stable Marriage instance given in Table 1. Assume that the population size n is 3. In order to generate the 3 initial stable matchings, 3 random rotations are selected from the rotation poset, namely: ρ_0, ρ_1, ρ_5 . Since ρ_0 has no predecessors, the stable matching that ρ_0 corresponds is obtained by exposing ρ_0 on M_0 , resulting in M_1 . Similarly, the closed subset obtained by adding all predecessors of ρ_1 corresponds to M_2 and the closed subset for ρ_5 corresponds to M_4 . Thus, the current population is: $\mathbf{P} = \langle M_1, M_2, M_4 \rangle$.

Evaluation

For each stable matching M_i , we denote by b_i its robustness value for (1,b)-supermatch. At the evaluation step, we compute the value b_i of each stable matching $M_i \in \mathbf{P}$. Then, a fitness value v_i is assigned to each M_i in the population. This is to indicate that a stable matching with a lower b value is more fit. Then, the values v_i are normalised in the interval $[0, 1]$.

Let max_b denote the maximum b value in the population. The first thing required is to get the complements of the numbers with max_b to indicate that a stable matching with a

smaller b is a more fit solution. In the meantime, a small constant c_0 is added to each v_i to make sure even the least fit stable matching M_i , where $b_i = max_b$, is still an eligible solution (Equation 3). Then, the normalization is applied as shown in Equation 4. For normalization, an integer variable sum_v is used to keep track of the sum of the total fitness values in the population.

$$v_i = max_b + c_0 - b_i \quad (3)$$

$$v_i = \frac{v_i}{\sum_{M_i \in \mathbf{P}} v_i} \quad (4)$$

The steps are detailed in Algorithm 3.

Algorithm 3 Evaluation of Fitness Values of each Stable Matching

```

1: procedure EVALUATION()
2:    $max_b \leftarrow 0$ 
3:   for  $M_i \in \mathbf{P}$  do
4:     if  $b_i > max_b$  then
5:        $max_b \leftarrow b_i$ 
6:    $sum_v \leftarrow 0$ 
7:   for  $M_i \in \mathbf{P}$  do
8:      $v_i \leftarrow (max_b + c_0 - b_i)$ 
9:      $sum_v \leftarrow (sum_v + v_i)$ 
10:  for  $M_i \in \mathbf{P}$  do
11:     $v_i \leftarrow (v_i / sum_v)$ 

```

The b values for the stable matchings given in our example, where $\mathbf{P} = \langle M_1, M_2, M_4 \rangle$ are calculated as $b_1 = 4, b_2 = 3, b_4 = 3$ by the polynomial procedure defined in Section 3. Given these values, $b_{max} = 4$. Let us fix c_0 to 0.5. Then, the fitness values are calculated as $v_1 = 4 + 0.5 - 4 = 0.5, v_2 = 4 + 0.5 - 3 = 1.5, v_4 = 4 + 0.5 - 3 = 1.5$ and the sum of the fitness values is $sum_v = v_1 + v_2 + v_4 = 3.5$. By normalizing the fitness values, we obtain the following values: $v_1 = 0.143, v_2 = 0.429, v_4 = 0.429$ indicating that M_2 and M_4 are the fittest stable matchings in \mathbf{P} .

Evolution

The evolution step consists in selecting stable matchings from the population \mathbf{P} using a selection method, then applying crossover and mutation on the selected matchings.

We use the roulette wheel selection in our procedure. Because it is a method favouring more fit solutions to be selected and therefore useful for the convergence of the population to a fit state [Goldberg, 1989]. Algorithm 4 gives details of the roulette wheel selection procedure we used. First, a random double number $r \in [0, 1]$ is generated. Then, the fitness values of the stable matchings in the population are visited. At each step, a sum of the fitness values seen so far are recorded in a variable named sum_c . This procedure continues until a stable matching M_i is found, where the recording sum_c up to M_i satisfies the criterion at line 5 in Algorithm 4.

The evolution step is then continued by applying crossover and mutation on selected stable matchings. First, two stable

Algorithm 4 Roulette Wheel Selection

```
1: procedure SELECTION()
2:    $r \leftarrow \text{RANDOMDOUBLE}(0, 1)$ 
3:    $sum_c \leftarrow 0$ 
4:   for  $M_i \in \mathbf{P}$  do
5:     if  $(sum_c \leq r) \wedge (r < sum_c + v_i)$  then return
        $M_i$ 
6:      $sum_c \leftarrow sum_c + v_i$ 
```

matchings are selected, namely M_1 and M_2 . If these matchings are different from each other, crossover is applied (between Lines 2 and 5 in Algorithm 5).

Algorithm 5 Evolution Phase

```
1: procedure EVOLUTION()
2:    $M_1 \leftarrow \text{SELECTION}()$ 
3:    $M_2 \leftarrow \text{SELECTION}()$ 
4:   if  $M_1 \neq M_2$  then
5:      $(M_{c1}, M_{c2}) \leftarrow \text{CROSSOVER}(M_1, M_2)$ 
6:      $\text{REFINE}(M_{c1}, M_{c2})$ 
7:      $\text{EVALUATION}()$ 
8:    $M_{fit} \leftarrow \text{GETFITTEST}(\mathbf{P})$ 
9:    $M_m \leftarrow \text{SELECTION}()$ 
10:  if  $M_m \neq M_{fit}$  then
11:     $\text{MUTATION}(M_m)$ 
```

After applying the crossover on M_1, M_2 and obtaining the resulting stable matchings M_{c1}, M_{c2} , we refine the population. Refinement is applied for adding adding more fit solutions to the population and removing the least fit solutions. The overall procedure is detailed in Algorithm 6. In the refinement procedure, M_{c1}, M_{c2} are immediately added to the population \mathbf{P} . Then, the worst two solutions, in other words the two least fit stable matchings M_{l1} and M_{l2} are found and removed from the population. Note that after the refinement procedure in line 7 in Algorithm 5, the evaluation must be repeated to properly evaluate the current fitness values in the population.

Algorithm 6 Refinement Procedure

```
1: procedure REFINE( $M_{c1}, M_{c2}$ )
2:    $\mathbf{P} \leftarrow \mathbf{P} \cup \{M_{c1}\}$ 
3:    $\mathbf{P} \leftarrow \mathbf{P} \cup \{M_{c2}\}$ 
4:    $(M_{l1}, M_{l2}) \leftarrow \text{LEASTFITTWOSMS}(\mathbf{P})$ 
5:    $\mathbf{P} \leftarrow \mathbf{P} \setminus \{M_{l1}\}$ 
6:    $\mathbf{P} \leftarrow \mathbf{P} \setminus \{M_{l2}\}$ 
```

Subsequently, between the lines 8 and 11 of Algorithm 5, a stable matching M_m is selected for mutation. If M_m is different from the fittest stable matching M_{fit} , the mutation is applied. Mutation step may result in producing either better or worse solutions. We do not apply a refinement procedure after the mutations, instead directly apply the mutation on M_m . Next, we go into the details of the crossover and mutation operations.

Crossover. The procedure for crossover is detailed in Algorithm 7. Given two stable matchings M_1, M_2 and their corresponding closed subsets S_1 and S_2 , one random rotation is selected from each subset. Let ρ_1 and ρ_2 denote the randomly selected rotations. Between the lines 4 and 7, the procedure for creating a new closed subset S_{c2} from the closed subset S_2 is shown. The method is, if S_2 already contains the rotation ρ_1 , then S_{c2} is constructed by removing ρ_1 and all its successor rotations that are in S_2 from the set S_2 . We denote this removal process by the method REMOVE() in lines 5 and 9 in Algorithm 7. However, if $\rho_1 \notin S_2$, then ρ_1 and all its predecessors that are not included in S_2 are added to S_{c2} with the rotations that are already in S_2 to form the new closed subset S_{c2} . Similarly, we denote the addition process by the method ADD() in lines 7 and 11. This new closed subset S_{c2} corresponds to one of the stable matchings produced by crossover, M_{c2} . Similarly, the same process is repeated for S_1 by constructing S_{c1} , and another stable matching M_{c1} is obtained.

Algorithm 7 Crossover Procedure

```
1: procedure CROSSOVER( $M_1, M_2$ )
2:    $\rho_1 \leftarrow \text{RANDOM}(S_1)$ 
3:    $\rho_2 \leftarrow \text{RANDOM}(S_2)$ 
4:   if  $\rho_1 \in S_2$  then
5:      $S_{c2} \leftarrow \text{REMOVE}(S_2, \rho_1)$ 
6:   else
7:      $S_{c2} \leftarrow \text{ADD}(S_2, \rho_1)$ 
8:   if  $\rho_2 \in S_1$  then
9:      $S_{c1} \leftarrow \text{REMOVE}(S_1, \rho_2)$ 
10:  else
11:     $S_{c1} \leftarrow \text{ADD}(S_1, \rho_2)$ 
12:   $M_{c1} \leftarrow \text{CREATESM}(S_{c1})$ 
13:   $M_{c2} \leftarrow \text{CREATESM}(S_{c2})$ 
   return  $(M_{c1}, M_{c2})$ 
```

For the sake of the example, assume that M_1 and M_4 are selected for crossover by the roulette wheel selection from the current population $\mathbf{P} = \langle M_1, M_2, M_4 \rangle$. One random rotation is selected from each set: $\rho_0 \in S_1$ and $\rho_4 \in S_4$. Then, the produced stable matchings are M_3 since $\rho_4 \notin S_1$ and $\{\rho_0\} \cup \{\rho_4, \rho_1\} = S_3$, and M_0 by removing all rotations $\rho_0, \rho_1, \rho_4, \rho_5$ from S_4 . After adding new stable matchings, the population becomes $\mathbf{P} = \langle M_1, M_2, M_4, M_0, M_3 \rangle$. Then the population is refined by removing the least two fit stable matchings, which are in this case M_0 since $b_0 = 5$ and M_1 since $b_1 = 4$. Hence, the refined population after crossover is: $\mathbf{P} = \langle M_2, M_4, M_3 \rangle$.

Mutation. At this step, the mutation method is given a stable matching M . Let S denote its corresponding closed subset. The procedure starts by selecting a random rotation ρ from the rotation poset \mathcal{V} . Then, similar to the crossover procedure above, if $\rho \notin S$, ρ and all its required predecessors to form a closed subset are added to S . However, if $\rho \in S$, then ρ and all its successors in S are removed from S . Algorithm 8 defines this procedure.

In order to demonstrate this step on the example popula-

Algorithm 8 Mutation Procedure

```
1: procedure MUTATION( $M$ )
2:    $\rho \leftarrow \text{RANDOM}(\mathcal{V})$ 
3:   if  $\rho \in S$  then
4:      $S \leftarrow \text{REMOVE}(S, \rho)$ 
5:   else
6:      $S \leftarrow \text{ADD}(S, \rho)$ 
```

tion, assume that M_3 has been selected for mutation and ρ_2 is randomly selected from the rotation poset. Since $\rho_2 \notin S_3$, ρ_2 and all its predecessors are added to S_3 , resulting in $\{\rho_0, \rho_1, \rho_4\} \cup \{\rho_2\} = S_6$. The new stable matching is M_6 is added to the population and the mutated stable matching, M_3 is deleted. The final population is: $\langle M_6, M_2, M_4 \rangle$.

The procedure for the overall algorithm is given in Algorithm 9. The evolution step is repeated until either a solution is found or the termination criteria are met. In our case, we have two termination criteria: a time limit lim_{time} and an iteration limit to cut-off the process if there is no improved solution for the specified number of iterations lim_{cutoff} . For cut-off termination criterion, we keep a counter cnt to count the number of iterations with no improvement, i.e. more fit solution than the current fittest solution. This counter is increased at each unimproved iteration until it reaches the cut-off limit. If a more fit solution is generated, cnt is restarted as $cnt = 0$.

In order to compute the b values of the stable matchings, we use the method described in the Section 3 for each stable matching. Recall that this procedure takes $O(n \times |\mathcal{V}|)$ time after a $O(n^2 + |\mathcal{V}|^2)$ preprocessing step. In order to speed up this process from a practical point of view, in our experiments an extra data structure is used to memorize the fitness value of already generated stable matchings. In both crossover and mutation, the worst case time complexity for one call is bounded by $O(|\mathcal{V}|)$ since the set of all predecessors (respectively successors) of a given node is $N_t^-(\rho)$ (respectively $N_t^+(\rho)$).

Algorithm 9 General Procedure of Genetic Algorithm

```
1: procedure GENETICALGORITHM()
2:    $P \leftarrow \text{INITIALIZE}(n)$ 
3:   EVALUATION()
4:    $M_{fit} \leftarrow null$ 
5:    $b_{fit} \leftarrow 0$ 
6:    $cnt \leftarrow 0$ 
7:   while  $time < lim_{time}$  or  $b_{fit}! = 1$  do
8:     EVOLUTION()
9:     EVALUATION()
10:    if  $M_{fit}$  is updated then
11:       $cnt \leftarrow 0$ 
12:    else
13:       $cnt \leftarrow cnt + 1$ 
14:    if  $cnt = lim_{cutoff}$  then
15:      return  $M_{fit}$ 
16:  return  $M_{fit}$ 
```

5.2 Local Search

In our local search model, we use the well-known iterated local search with restarts [Stützle, 1998; Lourenço *et al.*, 2010]. The first step of the algorithm is to find a random solution to start with. A random stable matching M is created by using the Initialization method detailed in Algorithm 2 in Section 5.1. Then, a neighbour stable match set is created using the properties of rotation poset.

A *neighbour* in this context is defined as a stable matching that differs only by one rotation from the closed subset S of the matching M . Let L_s denote the set of leaf rotations of S . Removing one rotation $\rho_i \in L_s$ from S corresponds to a different dominating neighbour of M . Similarly, let N_s denote the set of rotations that are not included in S and either they have an in-degree of 0 or all of their predecessors are in S . In the same manner, adding a rotation from N_s to S at a time corresponds to a different dominated neighbour of M .

Figure 3 illustrates a sample rotation poset, where the closed subset is $S = \{\rho_0, \rho_1, \rho_3, \rho_4, \rho_5, \rho_7\}$. Then, the set of leaf rotations in this set is identified as $L_s = \{\rho_1, \rho_4, \rho_7\}$. Similarly, the set of neighbour rotations is $N_s = \{\rho_2, \rho_6\}$ since all their predecessors are included in the closed subset S .

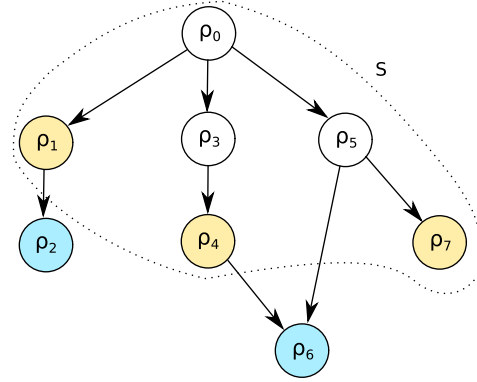

Figure 3: Illustration of the sets $L_s = \{\rho_1, \rho_4, \rho_7\}$ and $N_s = \{\rho_2, \rho_6\}$ on a sample rotation poset for a given closed subset S .

These two sets correspond to rotations, where removal of any rotation $\rho \in L_s$ from S at a time does not require removal of any other rotations in order to obtain another closed subset, i.e. a neighbour. Likewise, adding any rotation $\rho \in N_s$ to S does not require adding any additional rotations to obtain a closed subset. Algorithm 10 expands on the procedure for identifying the set of neighbour stable matchings N of a given stable matching M . The lines between 3 and 11 details the procedure of finding the rotations ρ in N_s . Similarly, the lines between 12 and 19 defines the procedure for identifying the leaf nodes ρ in L_s . The neighbour stable matchings are denoted by M_n . In this procedure, a variable called cnt is used to count the number of incoming edges of ρ , where the source node is not in S and then to count the number of outgoing edges whose target node is a member of S .

The general procedure is detailed in Algorithm 11. At each iteration, if a neighbour has lower b than M , in other words, it

Algorithm 10 Identification of Neighbour Set

```
1: procedure FINDNEIGHBOURS( $M$ )
2:    $N \leftarrow \emptyset$ 
3:   for  $\rho \in \mathcal{V}$  do
4:     if  $\rho \notin S$  then
5:        $cnt \leftarrow 0$ 
6:       for  $e \in \text{INCOMINGEDGES}(\rho)$  do
7:         if  $e.source \notin S$  then
8:            $cnt \leftarrow cnt + 1$ 
9:       if  $cnt = 0$  then
10:         $M_n \leftarrow \text{CREATESM}(S \cup \{\rho\})$ 
11:         $N \leftarrow N \cup \{M_n\}$ 
12:   for  $\rho \in S$  do
13:      $cnt \leftarrow 0$ 
14:     for  $e \in \text{OUTGOINGEDGES}(\rho)$  do
15:       if  $e.target \in S$  then
16:          $cnt \leftarrow cnt + 1$ 
17:     if  $cnt = 0$  then
18:        $M_n \leftarrow \text{CREATESM}(S \setminus \{\rho\})$ 
19:        $N \leftarrow N \cup \{M_n\}$ 
20:   return  $N$ 
```

is a more robust solution, the search continues by finding the neighbours of the new solution. A variable M_{best} is used to keep track of the best solution found so far in the whole search process. We denote the best stable matching in set N by M_{nb} and the function $\text{BEST}(N)$ is used to find the stable matching with the lowest b in set N . Also a counter cnt is used to count the number of iterations with no improved solutions. The cut-off limit is bounded by a variable denoted by lim_{cutoff} in the algorithm. There is an iteration limit lim_{depth} that indicates the depth of searching for neighbours of a randomly created stable matching. After the iteration limit is met, a new random stable matching is generated and the neighbour search continues from that stable matching.

Let us illustrate the neighbourhood search on the Stable Marriage instance given in Table 1. Assume that the search starts with a randomly generated stable matching, M_5 , where $S_5 = \{\rho_0, \rho_1, \rho_2\}$. The sets L_{S_5} and N_{S_5} are identified as follows: $L_{S_5} = \{\rho_2\}$, $N_{S_5} = \{\rho_3, \rho_4\}$. Thus the current stable matching has 3 neighbours:

$$\begin{aligned} S_5 \setminus \{\rho_2\} &= \{\rho_0, \rho_1\} = S_2 \\ S_5 \cup \{\rho_3\} &= \{\rho_0, \rho_1, \rho_2, \rho_3\} = S_8 \\ S_5 \cup \{\rho_4\} &= \{\rho_0, \rho_1, \rho_2, \rho_4\} = S_6. \end{aligned}$$

Next step is to calculate the robustness of each stable matching. Using the method described in Section 3, the b values are calculated as follows: $M_5.b = 3$, $M_2.b = 3$, $M_8.b = 3$, $M_6.b = 1$. Since M_6 is the most robust stable matching in the neighbourhood and better than the current stable matching M_5 , the neighbourhood search for the next step expands from M_6 .

Notice that there can be at most $|\mathcal{V}|$ neighbours of a stable matching. Thus, creating neighbours and finding their respective b values is $O(n \times |\mathcal{V}|^2)$.

Algorithm 11 General Procedure for Local Search

```
1: procedure LOCALSEARCH
2:    $M \leftarrow \text{CREATERANDOMSM}()$ 
3:    $M_{best} \leftarrow M$ 
4:    $cnt \leftarrow 0$ 
5:   while  $time < lim_{time}$  do
6:      $cnt \leftarrow 0$ 
7:      $iter_{depth} \leftarrow 0$ 
8:     while  $iter_{depth} \leq lim_{depth}$  do
9:        $cnt \leftarrow cnt + 1$ 
10:       $iter_{depth} \leftarrow iter_{depth} + 1$ 
11:       $N \leftarrow \text{FINDNEIGHBORS}(M)$ 
12:       $M_{nb} \leftarrow \text{BEST}(N)$ 
13:      if  $M_{nb}.b < M.b$  then
14:         $M \leftarrow M_{nb}$ 
15:        if  $M.b < M_{best}.b$  then
16:           $M_{best} \leftarrow M$ 
17:           $cnt \leftarrow 0$ 
18:        if  $cnt = lim_{cutoff}$  then
19:          return  $M_{best}$ 
20:    $M \leftarrow \text{CREATERANDOMSM}()$ 
21:   return  $M_{best}$ 
```

6 Experiments

We experimentally evaluate the three models for finding the most robust stable matching. The CP model is implemented in Choco 4.0.1 [Prud'homme *et al.*, 2016] and the two metaheuristics are implemented in Java. All experiments were performed on DELL M600 with 2.66 Ghz processors under Linux.

We ran each model with 4 different randomization seeds for each instance. The time limit is fixed to 20 minutes for every run. An additional cut-off is used for local search (LS) and genetic algorithm (GA) as follows: if the solution quality does not improve for 10000 iterations, we terminate the search. The genetic algorithm applies a crossover at each iteration unless the roulette wheel selection selects the fittest stable matching from the population. Additionally, the probability of applying mutation on a randomly selected stable matching is fixed as 80%. For local search, we chose to restart the local search with a randomly generated stable matching every 50 iterations. Last, the CP model (CP) uses the weighted degree heuristic [Boussemart *et al.*, 2004] with geometric restarts.

We use two sets of random instances. The first set contains 500 instances. The number of men for this set is in the set $\{300 + 50 * k\}$ where $k \in \{1, 5\}$. The second set contains 600 large instances of size $\{1200 + 50 * k\}$ where $k \in \{1, 6\}$. We generated 100 instances for each size for both benchmarks.

In Figures 4 and 5 we plot the normalized objective value of the best solution found by the search model $h \in \{\text{CP}, \text{GA}, \text{LS}\}$ (x -axis) after a given time (y -axis). Let $h(I)$ be the objective value of the best solution found using model h on instance I and $lb(I)$ (resp. $ub(I)$) the lowest (resp. highest) objective value found by any model on I . The formula below gives a normalized score in the interval $[0, 1]$:

Figure 4: Search Efficiency on the First Set of Instances

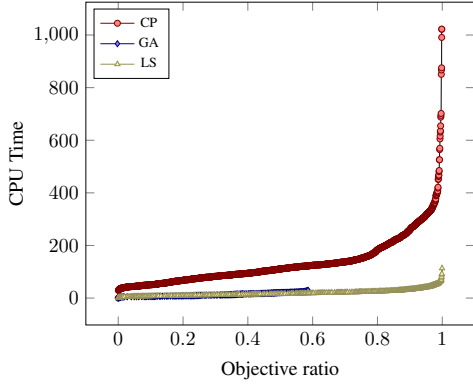
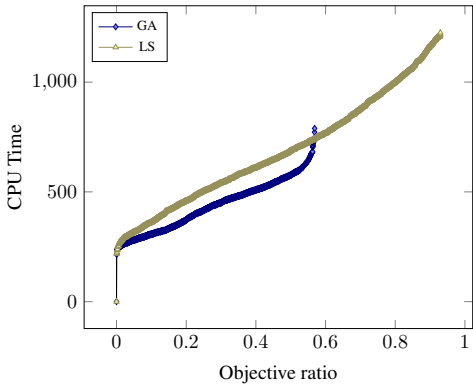

Figure 5: Search Efficiency on Large Instances



$$score(h, I) = \frac{ub(I) - h(I) + 1}{ub(I) - lb(I) + 1}$$

The value of $score(h, I)$ is equal to 1 if h has found the best solution for this instance among all models, decreases as $h(I)$ gets further from the optimal objective value, and is equal to 0 if and only if h did not find any solution for I .

Note that the CP model runs out of memory for large instances. Therefore, we do not plot it in Figure 5.

The outcome from both figures is clear. Local search is extremely efficient both in the quality of the solutions, and in runtime. Indeed, in the first plot, the best solutions are found by LS and CP. However, CP takes much longer time. Note that in Figure 4, CP and LS both find almost always the same objective, and in fact CP claims that the solution is optimal in all instances except one.

The GA model does not seem to be well suited for this problem. In the first data set it does not find the best solutions in all instances. Moreover, it clearly takes much longer time than CP and LS for finding good quality solutions.

The results in Figure 5 are more spectacular for local search. Local search does not always find the best solutions since the normalised objective ratio does not exceed 90%. However, the overall performance is clearly better than GA in both quality and runtime.

7 Conclusions

We studied the notion of robustness in stable matching problems by using the notion of (a, b) -supermatch. We first showed that the problem of finding a stable matching M_i that is closest to a given stable matching M if a pair (man, woman) decides to break their match in M can be found in polynomial time. Then, we used essentially this procedure to model the problem of finding the most robust stable matching using a CP formulation, local search, and genetic algorithm. Last, we empirically evaluated these models on randomly generated instances and showed that local search is by far the best model to find robust solutions.

To the best of our knowledge, this notion of robustness in stable matchings has never been proposed before. We hope that the proposed problem will get some attention in the future as it represents a challenge in real-world settings.

Acknowledgments

This publication has emanated from research conducted with the financial support of Science Foundation Ireland (SFI) under Grant Number SFI/12/RC/2289.

A CP Model

Below is an overview of the CP model for the Stable Marriage instance provided in Table 1.

As an example, find below the full CP model of the sample Stable Marriage instance given in Table 1. The set of stable pairs, $SP = \{\langle m_0, w_5 \rangle, \langle m_0, w_2 \rangle, \langle m_0, w_4 \rangle, \langle m_0, w_1 \rangle, \langle m_1, w_4 \rangle, \langle m_1, w_5 \rangle, \langle m_1, w_3 \rangle, \langle m_2, w_6 \rangle, \langle m_2, w_0 \rangle, \langle m_3, w_3 \rangle, \langle m_3, w_5 \rangle, \langle m_4, w_1 \rangle, \langle m_4, w_4 \rangle, \langle m_5, w_0 \rangle, \langle m_5, w_4 \rangle, \langle m_6, w_2 \rangle, \langle m_6, w_5 \rangle, \langle m_6, w_0 \rangle, \langle m_6, w_6 \rangle\}$.

The constraints ensuring if a pair is a part of the solution by checking the existence of the rotations that produces and eliminates each pair:

$$\begin{aligned} x_{0,5} &\leftrightarrow \neg s_0 \\ x_{0,2} &\leftrightarrow s_0 \wedge \neg s_2 \\ x_{0,4} &\leftrightarrow s_2 \wedge \neg s_3 \\ x_{0,1} &\leftrightarrow s_3 \\ x_{1,4} &\leftrightarrow \neg s_1 \\ x_{1,5} &\leftrightarrow s_1 \wedge \neg s_5 \\ x_{1,3} &\leftrightarrow s_5 \\ x_{2,6} &\leftrightarrow \neg s_4 \\ x_{2,0} &\leftrightarrow s_4 \\ x_{3,3} &\leftrightarrow \neg s_5 \\ x_{3,5} &\leftrightarrow s_5 \\ x_{4,1} &\leftrightarrow \neg s_3 \\ x_{4,4} &\leftrightarrow s_3 \\ x_{5,0} &\leftrightarrow \neg s_1 \\ x_{5,4} &\leftrightarrow s_1 \wedge \neg s_2 \\ x_{5,2} &\leftrightarrow s_2 \\ x_{6,2} &\leftrightarrow \neg s_0 \\ x_{6,5} &\leftrightarrow s_0 \wedge \neg s_1 \\ x_{6,0} &\leftrightarrow s_1 \wedge \neg s_4 \\ x_{6,6} &\leftrightarrow s_4 \end{aligned}$$

The constraints to make sure the solution forms a closed subset by requiring all predecessors of each rotation:

$$s_1 \rightarrow s_0$$

$$\begin{aligned}
s_2 &\rightarrow s_1 \\
s_3 &\rightarrow s_2 \\
s_4 &\rightarrow s_1 \\
s_5 &\rightarrow s_4
\end{aligned}$$

The constraints that handle the case if a man is matched to his best possible partner:

$$\begin{aligned}
\alpha_0 &\leftrightarrow x_{0,5} \\
\alpha_1 &\leftrightarrow x_{1,4} \\
\alpha_2 &\leftrightarrow x_{2,6} \\
\alpha_3 &\leftrightarrow x_{3,3} \\
\alpha_4 &\leftrightarrow x_{4,1} \\
\alpha_5 &\leftrightarrow x_{5,0} \\
\alpha_6 &\leftrightarrow x_{6,2}
\end{aligned}$$

The constraints to state if a couple is no longer wanted, the rotation that produces the couple must be removed from the solution closed subset:

$$\begin{aligned}
x_{0,2} &\leftrightarrow s_{up_0}^0 \\
x_{0,4} &\leftrightarrow s_{up_2}^0 \\
x_{0,1} &\leftrightarrow s_{up_3}^0 \\
x_{1,5} &\leftrightarrow s_{up_1}^1 \\
x_{1,3} &\leftrightarrow s_{up_5}^1 \\
x_{2,0} &\leftrightarrow s_{up_4}^2 \\
x_{3,5} &\leftrightarrow s_{up_5}^3 \\
x_{4,4} &\leftrightarrow s_{up_3}^4 \\
x_{5,4} &\leftrightarrow s_{up_1}^5 \\
x_{5,2} &\leftrightarrow s_{up_2}^5 \\
x_{6,5} &\leftrightarrow s_{up_0}^6 \\
x_{6,0} &\leftrightarrow s_{up_1}^6 \\
x_{6,6} &\leftrightarrow s_{up_4}^6
\end{aligned}$$

The constraints that ensure there does not exist a repair matching S_{UP}^{c*i} for man i if he is matched to his best possible partner:

$$\begin{aligned}
\alpha_0 &\rightarrow \neg s_{up_0}^0 \wedge \neg s_{up_1}^0 \wedge \neg s_{up_2}^0 \wedge \neg s_{up_3}^0 \wedge \neg s_{up_4}^0 \wedge \neg s_{up_5}^0 \\
\alpha_1 &\rightarrow \neg s_{up_0}^1 \wedge \neg s_{up_1}^1 \wedge \neg s_{up_2}^1 \wedge \neg s_{up_3}^1 \wedge \neg s_{up_4}^1 \wedge \neg s_{up_5}^1 \\
\alpha_2 &\rightarrow \neg s_{up_0}^2 \wedge \neg s_{up_1}^2 \wedge \neg s_{up_2}^2 \wedge \neg s_{up_3}^2 \wedge \neg s_{up_4}^2 \wedge \neg s_{up_5}^2 \\
\alpha_3 &\rightarrow \neg s_{up_0}^3 \wedge \neg s_{up_1}^3 \wedge \neg s_{up_2}^3 \wedge \neg s_{up_3}^3 \wedge \neg s_{up_4}^3 \wedge \neg s_{up_5}^3 \\
\alpha_4 &\rightarrow \neg s_{up_0}^4 \wedge \neg s_{up_1}^4 \wedge \neg s_{up_2}^4 \wedge \neg s_{up_3}^4 \wedge \neg s_{up_4}^4 \wedge \neg s_{up_5}^4 \\
\alpha_5 &\rightarrow \neg s_{up_0}^5 \wedge \neg s_{up_1}^5 \wedge \neg s_{up_2}^5 \wedge \neg s_{up_3}^5 \wedge \neg s_{up_4}^5 \wedge \neg s_{up_5}^5 \\
\alpha_6 &\rightarrow \neg s_{up_0}^6 \wedge \neg s_{up_1}^6 \wedge \neg s_{up_2}^6 \wedge \neg s_{up_3}^6 \wedge \neg s_{up_4}^6 \wedge \neg s_{up_5}^6
\end{aligned}$$

The constraints that require if a rotation is in the difference set $S \setminus S_{UP}^{*i}$, then all successors of that rotation that are a part of solution is also in the difference set when $i = 0$:

$$\begin{aligned}
s_{up_0}^0 \wedge s_1 &\rightarrow s_{up_1}^0 \\
s_{up_0}^0 \wedge s_2 &\rightarrow s_{up_2}^0 \\
s_{up_0}^0 \wedge s_3 &\rightarrow s_{up_3}^0 \\
s_{up_0}^0 \wedge s_4 &\rightarrow s_{up_4}^0 \\
s_{up_0}^0 \wedge s_5 &\rightarrow s_{up_5}^0 \\
s_{up_1}^0 \wedge s_2 &\rightarrow s_{up_2}^0 \\
s_{up_1}^0 \wedge s_3 &\rightarrow s_{up_3}^0 \\
s_{up_1}^0 \wedge s_4 &\rightarrow s_{up_4}^0
\end{aligned}$$

$$\begin{aligned}
s_{up_1}^0 \wedge s_5 &\rightarrow s_{up_5}^0 \\
s_{up_2}^0 \wedge s_3 &\rightarrow s_{up_3}^0 \\
s_{up_4}^0 \wedge s_5 &\rightarrow s_{up_5}^0
\end{aligned}$$

when $i = 1$

$$\begin{aligned}
s_{up_0}^1 \wedge s_1 &\rightarrow s_{up_1}^1 \\
s_{up_0}^1 \wedge s_2 &\rightarrow s_{up_2}^1 \\
s_{up_0}^1 \wedge s_3 &\rightarrow s_{up_3}^1 \\
s_{up_0}^1 \wedge s_4 &\rightarrow s_{up_4}^1 \\
s_{up_0}^1 \wedge s_5 &\rightarrow s_{up_5}^1 \\
s_{up_1}^1 \wedge s_2 &\rightarrow s_{up_2}^1 \\
s_{up_1}^1 \wedge s_3 &\rightarrow s_{up_3}^1 \\
s_{up_1}^1 \wedge s_4 &\rightarrow s_{up_4}^1 \\
s_{up_1}^1 \wedge s_5 &\rightarrow s_{up_5}^1 \\
s_{up_2}^1 \wedge s_3 &\rightarrow s_{up_3}^1 \\
s_{up_4}^1 \wedge s_5 &\rightarrow s_{up_5}^1
\end{aligned}$$

when $i = 2$

$$\begin{aligned}
s_{up_0}^2 \wedge s_1 &\rightarrow s_{up_1}^2 \\
s_{up_0}^2 \wedge s_2 &\rightarrow s_{up_2}^2 \\
s_{up_0}^2 \wedge s_3 &\rightarrow s_{up_3}^2 \\
s_{up_0}^2 \wedge s_4 &\rightarrow s_{up_4}^2 \\
s_{up_0}^2 \wedge s_5 &\rightarrow s_{up_5}^2 \\
s_{up_1}^2 \wedge s_2 &\rightarrow s_{up_2}^2 \\
s_{up_1}^2 \wedge s_3 &\rightarrow s_{up_3}^2 \\
s_{up_1}^2 \wedge s_4 &\rightarrow s_{up_4}^2 \\
s_{up_1}^2 \wedge s_5 &\rightarrow s_{up_5}^2 \\
s_{up_2}^2 \wedge s_3 &\rightarrow s_{up_3}^2 \\
s_{up_4}^2 \wedge s_5 &\rightarrow s_{up_5}^2
\end{aligned}$$

when $i = 3$

$$\begin{aligned}
s_{up_0}^3 \wedge s_1 &\rightarrow s_{up_1}^3 \\
s_{up_0}^3 \wedge s_2 &\rightarrow s_{up_2}^3 \\
s_{up_0}^3 \wedge s_3 &\rightarrow s_{up_3}^3 \\
s_{up_0}^3 \wedge s_4 &\rightarrow s_{up_4}^3 \\
s_{up_0}^3 \wedge s_5 &\rightarrow s_{up_5}^3 \\
s_{up_1}^3 \wedge s_2 &\rightarrow s_{up_2}^3 \\
s_{up_1}^3 \wedge s_3 &\rightarrow s_{up_3}^3 \\
s_{up_1}^3 \wedge s_4 &\rightarrow s_{up_4}^3 \\
s_{up_1}^3 \wedge s_5 &\rightarrow s_{up_5}^3 \\
s_{up_2}^3 \wedge s_3 &\rightarrow s_{up_3}^3 \\
s_{up_4}^3 \wedge s_5 &\rightarrow s_{up_5}^3
\end{aligned}$$

when $i = 4$

$$\begin{aligned}
s_{up_0}^4 \wedge s_1 &\rightarrow s_{up_1}^4 \\
s_{up_0}^4 \wedge s_2 &\rightarrow s_{up_2}^4 \\
s_{up_0}^4 \wedge s_3 &\rightarrow s_{up_3}^4 \\
s_{up_0}^4 \wedge s_4 &\rightarrow s_{up_4}^4 \\
s_{up_0}^4 \wedge s_5 &\rightarrow s_{up_5}^4 \\
s_{up_1}^4 \wedge s_2 &\rightarrow s_{up_2}^4 \\
s_{up_1}^4 \wedge s_3 &\rightarrow s_{up_3}^4 \\
s_{up_1}^4 \wedge s_4 &\rightarrow s_{up_4}^4
\end{aligned}$$

$$\begin{aligned} s_{up_1}^4 \wedge s_5 &\rightarrow s_{up_5}^4 \\ s_{up_2}^4 \wedge s_3 &\rightarrow s_{up_3}^4 \\ s_{up_4}^4 \wedge s_5 &\rightarrow s_{up_5}^4 \end{aligned}$$

when $i = 5$

$$\begin{aligned} s_{up_0}^5 \wedge s_1 &\rightarrow s_{up_1}^5 \\ s_{up_0}^5 \wedge s_2 &\rightarrow s_{up_2}^5 \\ s_{up_0}^5 \wedge s_3 &\rightarrow s_{up_3}^5 \\ s_{up_0}^5 \wedge s_4 &\rightarrow s_{up_4}^5 \\ s_{up_0}^5 \wedge s_5 &\rightarrow s_{up_5}^5 \\ s_{up_1}^5 \wedge s_2 &\rightarrow s_{up_2}^5 \\ s_{up_1}^5 \wedge s_3 &\rightarrow s_{up_3}^5 \\ s_{up_1}^5 \wedge s_4 &\rightarrow s_{up_4}^5 \\ s_{up_1}^5 \wedge s_5 &\rightarrow s_{up_5}^5 \\ s_{up_2}^5 \wedge s_3 &\rightarrow s_{up_3}^5 \\ s_{up_4}^5 \wedge s_5 &\rightarrow s_{up_5}^5 \end{aligned}$$

when $i = 6$

$$\begin{aligned} s_{up_0}^6 \wedge s_1 &\rightarrow s_{up_1}^6 \\ s_{up_0}^6 \wedge s_2 &\rightarrow s_{up_2}^6 \\ s_{up_0}^6 \wedge s_3 &\rightarrow s_{up_3}^6 \\ s_{up_0}^6 \wedge s_4 &\rightarrow s_{up_4}^6 \\ s_{up_0}^6 \wedge s_5 &\rightarrow s_{up_5}^6 \\ s_{up_1}^6 \wedge s_2 &\rightarrow s_{up_2}^6 \\ s_{up_1}^6 \wedge s_3 &\rightarrow s_{up_3}^6 \\ s_{up_1}^6 \wedge s_4 &\rightarrow s_{up_4}^6 \\ s_{up_1}^6 \wedge s_5 &\rightarrow s_{up_5}^6 \\ s_{up_2}^6 \wedge s_3 &\rightarrow s_{up_3}^6 \\ s_{up_4}^6 \wedge s_5 &\rightarrow s_{up_5}^6 \end{aligned}$$

The constraints that ensure if a rotation is in the difference set $S \setminus S_{UP}^{*i}$, they must be a part of the solution and they are either the rotation that produces the couple in the solution or they have a predecessor that produces the couple. For

$v = \rho_0$:

$$\begin{aligned} s_{up_0}^0 &\rightarrow s_0 \wedge x_{0,2} \\ s_{up_0}^1 &\rightarrow s_0 \\ s_{up_0}^2 &\rightarrow s_0 \\ s_{up_0}^3 &\rightarrow s_0 \\ s_{up_0}^4 &\rightarrow s_0 \\ s_{up_0}^5 &\rightarrow s_0 \\ s_{up_0}^6 &\rightarrow s_0 \wedge x_{6,5} \end{aligned}$$

For $v = \rho_1$:

$$\begin{aligned} s_{up_1}^0 &\rightarrow s_1 \wedge s_{up_0}^0 \\ s_{up_1}^1 &\rightarrow s_1 \wedge (x_{1,5} \vee s_{up_0}^1) \\ s_{up_1}^2 &\rightarrow s_1 \wedge s_{up_0}^2 \\ s_{up_1}^3 &\rightarrow s_1 \wedge s_{up_0}^3 \\ s_{up_1}^4 &\rightarrow s_1 \wedge s_{up_0}^4 \\ s_{up_1}^5 &\rightarrow s_1 \wedge (x_{5,4} \vee s_{up_0}^5) \\ s_{up_1}^6 &\rightarrow s_1 \wedge (x_{6,0} \vee s_{up_0}^6) \end{aligned}$$

For $v = \rho_2$:

$$\begin{aligned} s_{up_2}^0 &\rightarrow s_2 \wedge (x_{0,4} \vee s_{up_0}^0 \vee s_{up_1}^0) \\ s_{up_2}^1 &\rightarrow s_2 \wedge (s_{up_0}^1 \vee s_{up_1}^1) \\ s_{up_2}^2 &\rightarrow s_2 \wedge (s_{up_0}^2 \vee s_{up_1}^2) \\ s_{up_2}^3 &\rightarrow s_2 \wedge (s_{up_0}^3 \vee s_{up_1}^3) \\ s_{up_2}^4 &\rightarrow s_2 \wedge (s_{up_0}^4 \vee s_{up_1}^4) \\ s_{up_2}^5 &\rightarrow s_2 \wedge (x_{5,4} \vee s_{up_0}^5 \vee s_{up_1}^5) \\ s_{up_2}^6 &\rightarrow s_2 \wedge (s_{up_0}^6 \vee s_{up_1}^6) \end{aligned}$$

For $v = \rho_3$:

$$\begin{aligned} s_{up_3}^0 &\rightarrow s_3 \wedge (x_{0,1} \vee s_{up_0}^0 \vee s_{up_1}^0 \vee s_{up_2}^0) \\ s_{up_3}^1 &\rightarrow s_3 \wedge (s_{up_0}^1 \vee s_{up_1}^1 \vee s_{up_2}^1) \\ s_{up_3}^2 &\rightarrow s_3 \wedge (s_{up_0}^2 \vee s_{up_1}^2 \vee s_{up_2}^2) \\ s_{up_3}^3 &\rightarrow s_3 \wedge (s_{up_0}^3 \vee s_{up_1}^3 \vee s_{up_2}^3) \\ s_{up_3}^4 &\rightarrow s_3 \wedge (x_{4,4} \vee s_{up_0}^4 \vee s_{up_1}^4 \vee s_{up_2}^4) \\ s_{up_3}^5 &\rightarrow s_3 \wedge (s_{up_0}^5 \vee s_{up_1}^5 \vee s_{up_2}^5) \\ s_{up_3}^6 &\rightarrow s_3 \wedge (s_{up_0}^6 \vee s_{up_1}^6 \vee s_{up_2}^6) \end{aligned}$$

For $v = \rho_4$:

$$\begin{aligned} s_{up_4}^0 &\rightarrow s_4 \wedge (s_{up_0}^0 \vee s_{up_1}^0) \\ s_{up_4}^1 &\rightarrow s_4 \wedge (s_{up_0}^1 \vee s_{up_1}^1) \\ s_{up_4}^2 &\rightarrow s_4 \wedge (x_{2,0} \vee s_{up_0}^2 \vee s_{up_1}^2) \\ s_{up_4}^3 &\rightarrow s_4 \wedge (s_{up_0}^3 \vee s_{up_1}^3) \\ s_{up_4}^4 &\rightarrow s_4 \wedge (s_{up_0}^4 \vee s_{up_1}^4) \\ s_{up_4}^5 &\rightarrow s_4 \wedge (s_{up_0}^5 \vee s_{up_1}^5) \\ s_{up_4}^6 &\rightarrow s_4 \wedge (x_{6,6} \vee s_{up_0}^6 \vee s_{up_1}^6) \end{aligned}$$

For $v = \rho_5$:

$$\begin{aligned} s_{up_5}^0 &\rightarrow s_5 \wedge (s_{up_0}^0 \vee s_{up_1}^0 \vee s_{up_4}^0) \\ s_{up_5}^1 &\rightarrow s_5 \wedge (x_{1,3} \vee s_{up_0}^1 \vee s_{up_1}^1 \vee s_{up_4}^1) \\ s_{up_5}^2 &\rightarrow s_5 \wedge (s_{up_0}^2 \vee s_{up_1}^2 \vee s_{up_4}^2) \\ s_{up_5}^3 &\rightarrow s_5 \wedge (x_{3,5} \vee s_{up_0}^3 \vee s_{up_1}^3 \vee s_{up_4}^3) \\ s_{up_5}^4 &\rightarrow s_5 \wedge (s_{up_0}^4 \vee s_{up_1}^4 \vee s_{up_4}^4) \\ s_{up_5}^5 &\rightarrow s_5 \wedge (s_{up_0}^5 \vee s_{up_1}^5 \vee s_{up_4}^5) \\ s_{up_5}^6 &\rightarrow s_5 \wedge (s_{up_0}^6 \vee s_{up_1}^6 \vee s_{up_4}^6) \end{aligned}$$

The constraints for construction of the difference set $S_{DOWN}^{*i} \setminus S$ can also be generated similar to the difference set constraints above. We do not include those constraints here for space limitations.

For the counting constraints, following are for counting which other men are required to change their couples in order to repair man i for difference set $S \setminus S_{UP}^{*i}$, when $i = 0$:

$$\begin{aligned} y_1^0 &\leftrightarrow s_{up_1}^0 \vee s_{up_5}^0 \\ y_2^0 &\leftrightarrow s_{up_4}^0 \\ y_3^0 &\leftrightarrow s_{up_5}^0 \\ y_4^0 &\leftrightarrow s_{up_3}^0 \\ y_5^0 &\leftrightarrow s_{up_1}^0 \vee s_{up_2}^0 \\ y_6^0 &\leftrightarrow s_{up_0}^0 \vee s_{up_1}^0 \vee s_{up_4}^0 \end{aligned}$$

when $i = 1$:

$$\begin{aligned} y_0^1 &\leftrightarrow s_{up_0}^1 \vee s_{up_2}^1 \vee s_{up_3}^1 \\ y_2^1 &\leftrightarrow s_{up_4}^1 \\ y_3^1 &\leftrightarrow s_{up_5}^1 \end{aligned}$$

$$\begin{aligned} y_4^1 &\leftrightarrow s_{up_3}^1 \\ y_5^1 &\leftrightarrow s_{up_1}^1 \vee s_{up_2}^1 \\ y_6^1 &\leftrightarrow s_{up_0}^1 \vee s_{up_1}^1 \vee s_{up_4}^1 \end{aligned}$$

when $i = 2$:

$$\begin{aligned} y_0^2 &\leftrightarrow s_{up_0}^2 \vee s_{up_2}^2 \vee s_{up_3}^2 \\ y_1^2 &\leftrightarrow s_{up_1}^2 \vee s_{up_5}^2 \\ y_3^2 &\leftrightarrow s_{up_5}^2 \\ y_4^2 &\leftrightarrow s_{up_3}^2 \\ y_5^2 &\leftrightarrow s_{up_1}^2 \vee s_{up_2}^2 \\ y_6^2 &\leftrightarrow s_{up_0}^2 \vee s_{up_1}^2 \vee s_{up_4}^2 \end{aligned}$$

when $i = 3$:

$$\begin{aligned} y_0^3 &\leftrightarrow s_{up_0}^3 \vee s_{up_2}^3 \vee s_{up_3}^3 \\ y_1^3 &\leftrightarrow s_{up_1}^3 \vee s_{up_5}^3 \\ y_2^3 &\leftrightarrow s_{up_4}^3 \\ y_4^3 &\leftrightarrow s_{up_3}^3 \\ y_5^3 &\leftrightarrow s_{up_1}^3 \vee s_{up_2}^3 \\ y_6^3 &\leftrightarrow s_{up_0}^3 \vee s_{up_1}^3 \vee s_{up_4}^3 \end{aligned}$$

when $i = 4$:

$$\begin{aligned} y_0^4 &\leftrightarrow s_{up_0}^4 \vee s_{up_2}^4 \vee s_{up_3}^4 \\ y_1^4 &\leftrightarrow s_{up_1}^4 \vee s_{up_5}^4 \\ y_2^4 &\leftrightarrow s_{up_4}^4 \\ y_3^4 &\leftrightarrow s_{up_5}^4 \\ y_5^4 &\leftrightarrow s_{up_1}^4 \vee s_{up_2}^4 \\ y_6^4 &\leftrightarrow s_{up_0}^4 \vee s_{up_1}^4 \vee s_{up_4}^4 \end{aligned}$$

when $i = 5$:

$$\begin{aligned} y_0^5 &\leftrightarrow s_{up_0}^5 \vee s_{up_2}^5 \vee s_{up_3}^5 \\ y_1^5 &\leftrightarrow s_{up_1}^5 \vee s_{up_5}^5 \\ y_2^5 &\leftrightarrow s_{up_4}^5 \\ y_3^5 &\leftrightarrow s_{up_5}^5 \\ y_4^5 &\leftrightarrow s_{up_3}^5 \\ y_6^5 &\leftrightarrow s_{up_0}^5 \vee s_{up_1}^5 \vee s_{up_4}^5 \end{aligned}$$

when $i = 6$:

$$\begin{aligned} y_0^6 &\leftrightarrow s_{up_0}^6 \vee s_{up_2}^6 \vee s_{up_3}^6 \\ y_1^6 &\leftrightarrow s_{up_1}^6 \vee s_{up_5}^6 \\ y_2^6 &\leftrightarrow s_{up_4}^6 \\ y_3^6 &\leftrightarrow s_{up_5}^6 \\ y_4^6 &\leftrightarrow s_{up_3}^6 \\ y_5^6 &\leftrightarrow s_{up_1}^6 \vee s_{up_2}^6 \end{aligned}$$

For difference set $S_{DOWN}^{*i} \setminus S$, the constraints are the same except the boolean variables y is replaced with z and s_{up} is replaced with s_{down} .

The constraints for counting how many other men are required to change their partners in order to provide a repair stable matching that dominates the current matching:

$$\begin{aligned} \alpha_0 = \text{true} &\rightarrow d_{up}^0 = n, \text{ else } \rightarrow d_{up}^0 = y_1^0 + y_2^0 + y_3^0 + y_4^0 + y_5^0 + y_6^0 \\ \alpha_1 = \text{true} &\rightarrow d_{up}^1 = n, \text{ else } \rightarrow d_{up}^1 = y_0^1 + y_2^1 + y_3^1 + y_4^1 + y_5^1 + y_6^1 \end{aligned}$$

$$\begin{aligned} \alpha_2 = \text{true} &\rightarrow d_{up}^2 = n, \text{ else } \rightarrow d_{up}^2 = y_0^2 + y_1^2 + y_3^2 + y_4^2 + y_5^2 + y_6^2 \\ \alpha_3 = \text{true} &\rightarrow d_{up}^3 = n, \text{ else } \rightarrow d_{up}^3 = y_0^3 + y_1^3 + y_2^3 + y_4^3 + y_5^3 + y_6^3 \\ \alpha_4 = \text{true} &\rightarrow d_{up}^4 = n, \text{ else } \rightarrow d_{up}^4 = y_0^4 + y_1^4 + y_2^4 + y_3^4 + y_4^4 + y_6^4 \\ \alpha_5 = \text{true} &\rightarrow d_{up}^5 = n, \text{ else } \rightarrow d_{up}^5 = y_0^5 + y_1^5 + y_2^5 + y_3^5 + y_4^5 + y_6^5 \\ \alpha_6 = \text{true} &\rightarrow d_{up}^6 = n, \text{ else } \rightarrow d_{up}^6 = y_0^6 + y_1^6 + y_2^6 + y_3^6 + y_4^6 + y_5^6 \end{aligned}$$

Similarly, the repairs required for the dominated stable matching: $\beta_0 = \text{true} \rightarrow d_{down}^0 = n$, else

$$\begin{aligned} \rightarrow d_{down}^0 &= z_1^0 + z_2^0 + z_3^0 + z_4^0 + z_5^0 + z_6^0 \\ \beta_1 = \text{true} &\rightarrow d_{down}^1 = n, \text{ else } \rightarrow d_{down}^1 = z_0^1 + z_2^1 + z_3^1 + z_4^1 + z_5^1 + z_6^1 \\ \beta_2 = \text{true} &\rightarrow d_{down}^2 = n, \text{ else } \rightarrow d_{down}^2 = z_0^2 + z_1^2 + z_3^2 + z_4^2 + z_5^2 + z_6^2 \\ \beta_3 = \text{true} &\rightarrow d_{down}^3 = n, \text{ else } \rightarrow d_{down}^3 = z_0^3 + z_1^3 + z_2^3 + z_4^3 + z_5^3 + z_6^3 \\ \beta_4 = \text{true} &\rightarrow d_{down}^4 = n, \text{ else } \rightarrow d_{down}^4 = z_0^4 + z_1^4 + z_2^4 + z_3^4 + z_5^4 + z_6^4 \\ \beta_5 = \text{true} &\rightarrow d_{down}^5 = n, \text{ else } \rightarrow d_{down}^5 = z_0^5 + z_1^5 + z_2^5 + z_3^5 + z_4^5 + z_6^5 \\ \beta_6 = \text{true} &\rightarrow d_{down}^6 = n, \text{ else } \rightarrow d_{down}^6 = z_0^6 + z_1^6 + z_2^6 + z_3^6 + z_4^6 + z_5^6 \end{aligned}$$

The constraint for measuring the robustness of the solution:

$$\begin{aligned} &(\neg(\alpha_0) \rightarrow (b \geq d_{up}^0)) \vee (\neg(\beta_0) \rightarrow (b \geq d_{down}^0)) \\ &(\neg(\alpha_1) \rightarrow (b \geq d_{up}^1)) \vee (\neg(\beta_1) \rightarrow (b \geq d_{down}^1)) \\ &(\neg(\alpha_2) \rightarrow (b \geq d_{up}^2)) \vee (\neg(\beta_2) \rightarrow (b \geq d_{down}^2)) \\ &(\neg(\alpha_3) \rightarrow (b \geq d_{up}^3)) \vee (\neg(\beta_3) \rightarrow (b \geq d_{down}^3)) \\ &(\neg(\alpha_4) \rightarrow (b \geq d_{up}^4)) \vee (\neg(\beta_4) \rightarrow (b \geq d_{down}^4)) \\ &(\neg(\alpha_5) \rightarrow (b \geq d_{up}^5)) \vee (\neg(\beta_5) \rightarrow (b \geq d_{down}^5)) \\ &(\neg(\alpha_6) \rightarrow (b \geq d_{up}^6)) \vee (\neg(\beta_6) \rightarrow (b \geq d_{down}^6)) \end{aligned}$$

References

- [Bäck, 1996] Thomas Bäck. *Evolutionary Algorithms in Theory and Practice: Evolution Strategies, Evolutionary Programming, Genetic Algorithms*. Oxford University Press, Oxford, UK, 1996.
- [Boussaïd *et al.*, 2013] Ilhem Boussaïd, Julien Lepagnot, and Patrick Siarry. A survey on optimization metaheuristics. *Information Sciences*, 237:82 – 117, 2013. Prediction, Control and Diagnosis using Advanced Neural Computations.
- [Boussemart *et al.*, 2004] Frédéric Boussemart, Fred Hemery, Christophe Lecoutre, and Lakhdar Sais. Boosting systematic search by weighting constraints. In *Proceedings of the 16th European Conference on Artificial Intelligence – ECAI*, pages 146–150, 2004.

- [Climent, 2015] Laura Climent. Robustness and stability in dynamic constraint satisfaction problems. *Constraints*, 20(4):502–503, 2015.
- [Feder, 1992] Tomás Feder. A new fixed point approach for stable networks and stable marriages. *J. Comput. Syst. Sci.*, 45(2):233–284, 1992.
- [Fleiner *et al.*, 2007] Tamás Fleiner, Robert W. Irving, and David Manlove. Efficient algorithms for generalized stable marriage and roommates problems. *Theor. Comput. Sci.*, 381(1-3):162–176, 2007.
- [Gale and Shapley, 1962] D. Gale and L. S. Shapley. College Admissions and the Stability of Marriage. *The American Mathematical Monthly*, 69(1):9–15, January 1962.
- [Genc *et al.*, 2017] Begum Genc, Mohamed Siala, Barry O’Sullivan, and Gilles Simonin. Robust stable marriage. In *Proceedings of the Thirty-First AAAI Conference on Artificial Intelligence, February 4-9, 2017, San Francisco, California, USA.*, pages 4925–4926, 2017.
- [Ginsberg *et al.*, 1998] Matthew L. Ginsberg, Andrew J. Parkes, and Amitabha Roy. Supermodels and robustness. In *In AAAI/IAAI*, pages 334–339, 1998.
- [Goldberg, 1989] David E. Goldberg. *Genetic Algorithms in Search, Optimization and Machine Learning*. Addison-Wesley Longman Publishing Co., Inc., Boston, MA, USA, 1st edition, 1989.
- [Gusfield and Irving, 1989] Dan Gusfield and Robert W. Irving. *The Stable Marriage Problem: Structure and Algorithms*. MIT Press, Cambridge, MA, USA, 1989.
- [Hebrard *et al.*, 2004a] Emmanuel Hebrard, Brahim Hnich, and Toby Walsh. Super solutions in constraint programming. In *Integration of AI and OR Techniques in Constraint Programming for Combinatorial Optimization Problems, First International Conference, CPAIOR 2004, Nice, France, April 20-22, 2004, Proceedings*, pages 157–172, 2004.
- [Hebrard *et al.*, 2004b] Emmanuel Hebrard, Brahim Hnich, and Toby Walsh. Super solutions in constraint programming. In *Integration of AI and OR Techniques in Constraint Programming for Combinatorial Optimization Problems, First International Conference, CPAIOR 2004, Nice, France, April 20-22, 2004, Proceedings*, pages 157–172, 2004.
- [Hebrard, 2007] Emmanuel Hebrard. *Robust solutions for constraint satisfaction and optimisation under uncertainty*. PhD thesis, University of New South Wales, 2007.
- [Holland, 1975] J. H. Holland. *Adaptation in Natural and Artificial Systems*. University of Michigan Press, Ann Arbor, MI, USA, 1975.
- [Holland, 1992] John Holland. *Adaptation in Natural and Artificial Systems*. MIT Press, 1992.
- [Irving and Leather, 1986] Robert W Irving and Paul Leather. The complexity of counting stable marriages. *SIAM J. Comput.*, 15(3):655–667, August 1986.
- [Lourenço *et al.*, 2010] Helena R. Lourenço, Olivier C. Martin, and Thomas Stützle. Iterated Local Search: Framework and Applications Handbook of Metaheuristics. volume 146 of *International Series in Operations Research & Management Science*, chapter 12, pages 363–397. Springer US, Boston, MA, 2010.
- [Manlove, 2013] D.F. Manlove. *Algorithmics of Matching Under Preferences*. Series on theoretical computer science. World Scientific, 2013.
- [Prud’homme *et al.*, 2016] Charles Prud’homme, Jean-Guillaume Fages, and Xavier Lorca. *Choco Solver Documentation*. TASC, INRIA Rennes, LINA CNRS UMR 6241, COSLING S.A.S., 2016.
- [Rossi *et al.*, 2006] Francesca Rossi, Peter van Beek, and Toby Walsh. *Handbook of Constraint Programming (Foundations of Artificial Intelligence)*. Elsevier Science Inc., New York, NY, USA, 2006.
- [Roth *et al.*, 2005] Alvin Roth, Tayfun Sönmez, and Utku Unver. Pairwise kidney exchange. Game theory and information, EconWPA, 2005.
- [Siala and O’Sullivan, 2017] Mohamed Siala and Barry O’Sullivan. Rotation-based formulation for stable matching. In *Principles and Practice of Constraint Programming - 23rd International Conference, CP 2017, Melbourne, Australia, August 28 - September 1, 2017, Proceedings*, 2017.
- [Stützle, 1998] Thomas Stützle. *Local search algorithms for combinatorial problems: analysis, improvements, and new applications*. PhD thesis, TU Darmstadt, 1998.
- [Sussman, 2007] Gerald Jay Sussman. Building robust systems an essay, 2007.