

Finite State Markov Wiretap Channel with Delayed Feedback

Bin Dai, Zheng Ma, and Yuan Luo

Abstract

The mobile wireless communication channel is often modeled as a finite state Markov channel (FSMC). In this paper, we study the security issue in the mobile wireless communication systems by considering the FSMC with an eavesdropper, which we call the finite state Markov wiretap channel (FSM-WC). More specifically, the FSM-WC is a channel with one input (the transmitter) and two outputs (the legitimate receiver and the eavesdropper). The transition probability of the FSM-WC is controlled by a channel state which takes values in a finite set, and it undergoes a Markov process. We assume that the state is perfectly known by the legitimate receiver and the eavesdropper, and through a noiseless feedback channel, the legitimate receiver sends his received channel output and the state back to the transmitter after some time delay. The main contribution of this paper is as follows.

- First, we provide inner and outer bounds on the capacity-equivocation region of the FSM-WC with only delayed state feedback, and we show that these bounds meet for a degraded case (the eavesdropper's received symbol is a degraded version of the legitimate receiver's).
- Second, we provide inner and outer bounds on the capacity-equivocation region of the FSM-WC with delayed state and legitimate receiver's channel output feedback, and we also show that these bounds meet for the above degraded case.
- Third, unlike the fact that the delayed receiver's channel output feedback does not increase the capacity of the FSMC with only delayed state feedback, we find that for the degraded case, the delayed legitimate receiver's channel output feedback enhances the capacity-equivocation region of the FSM-WC with only delayed state feedback.

The above results are further explained via degraded Gaussian and Gaussian fading examples.

Index Terms

Capacity-equivocation region, delayed feedback, finite-state Markov channel, secrecy capacity, wiretap channel.

B. Dai is with the School of Information Science and Technology, Southwest JiaoTong University, Chengdu 610031, China, and with the State Key Laboratory of Integrated Services Networks, Xidian University, Xi'an, Shaanxi 710071, China, e-mail: daibin@home.swjtu.edu.cn.

Z. Ma is with the School of Information Science and Technology, Southwest JiaoTong University, Chengdu 610031, China, e-mail: zma@home.swjtu.edu.cn.

Y. Luo is with the computer science and engineering department, Shanghai Jiao Tong University, Shanghai 200240, China, Email: luoyuan@cs.sjtu.edu.cn.

I. INTRODUCTION

A. The finite state Markov channel

The finite state Markov channel (FSMC) is a discrete channel whose transition probability is controlled by a state which takes values in a finite set, and the state undergoes a Markov process. Wang et al. [1] and Zhang et al. [2] found that the FSMC was a useful model for the time-varying fading channels, and the capacity of the FSMC was studied by [3]. In practical mobile wireless communication systems, the channel state is usually obtained by the transmitter via the receiver's feedback, and this feedback is often not instantaneous, i.e., the transmitter often receives delayed state from the receiver. This communication scenario can be modeled as the finite state Markov channel with delayed feedback, see Figure 1. The model of Figure 1 was investigated by Viswanathan [4], and the capacity of this channel model was totally determined. Moreover, Viswanathan [4] pointed out that the delayed receiver's channel output feedback does not increase the capacity of the model of Figure 1, i.e., there is no need for the receiver to send his channel output back to the transmitter at each time instant. Other related works on the FSMC are in [5]-[10].

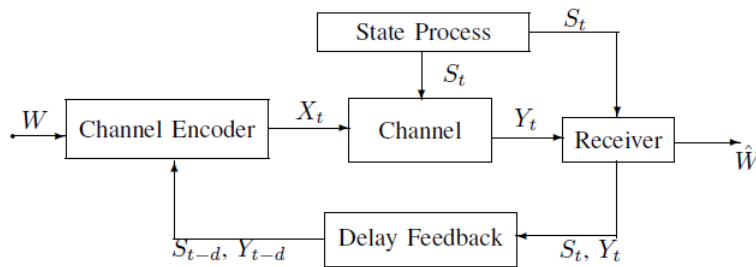

Fig. 1: The FSMC with delayed feedback

B. The wiretap channel

Wyner, in his landmark paper on the wiretap channel [11], first investigated the information-theoretic security in practical communication systems. In Wyner's wiretap channel model, a transmitter sends a private message to a legitimate receiver via a discrete memoryless main channel, and an eavesdropper eavesdrops the output of the main channel via a discrete memoryless wiretap channel. We say that the perfect secrecy is achieved if no information about the private message is leaked to the eavesdropper. The secrecy capacity, which was the maximum reliable transmission rate with perfect secrecy constraint, was characterized by Wyner [11]. After Wyner determined the secrecy capacity of the discrete memoryless wiretap channel model, Leung-Yan-Cheong and Hellman [12] investigated the Gaussian wiretap channel (GWC), where the noise of the main channel and the wiretap channel was Gaussian distributed. It was shown in [12] that the secrecy capacity of the GWC was obtained by subtracting

the capacity of the overall wiretap channel¹ from the capacity of the main channel. Wyner's work was generalized by Csiszár and Körner [13], where common and private messages were sent through a discrete memoryless general broadcast channel². The common message was assumed to be decoded correctly by both the legitimate receiver and the eavesdropper, while the private message was only allowed to be obtained by the legitimate receiver. The secrecy capacity region of this generalized model was characterized in [13], and later, Liang et al. [14] characterized the secrecy capacity region for the Gaussian case of Csiszár and Körner's model [13]. The work of [11] and [13] lays the foundation of the information-theoretic security in communication systems. Using the approach of [11] and [13], the security problems in multi-user communication channels, such as broadcast channel, multiple-access channel, relay channel, and interference channel, have been widely studied, see [15]-[30].

Recently, the wiretap channel with states has received much attention, see [31]-[35]. These works focus on the scenario that the states are identical independent distributed (i.i.d.), and to the best of the authors' knowledge, only Bloch et al. [36] and Sankarasubramaniam et al. [37] investigated the wiretap channel with memory states, where a stochastic algorithm for computing the multi-letter form secrecy capacity of this model was provided. A single-letter characterization for the secrecy capacity of [36] and [37] is still open.

C. Contributions of This Paper and Organization

In practical mobile wireless communication networks, security is a critical issue when people intend to transmit private information, such as the credit card transactions and the banking related data communications. The secure transmission of these private messages in the practical mobile wireless communication networks motivates us to study the finite-state Markov wiretap channel with delayed feedback, see the following Figure 2. In Figure 2, the transition probability of the channel at each time instant depends on a state which undergoes a finite-state Markov process. At time i , the receiver³ receives the channel output Y_i and the state S_i , and sends them back to the transmitter after a delay time d via a noiseless feedback channel. The channel encoder, at time i , generates the channel input according to the transmitted message W and the delayed feedback Y_{i-d} and S_{i-d} . Moreover, at time i , an eavesdropper receives the channel output Z_i and the state S_i , and he wishes to obtain the transmitted message W . The delay time d is perfectly known by the receiver, the eavesdropper and the transmitter. The main results of the model of Figure 2 are listed as follows.

- First, for the model of Figure 2 with only delayed state S_{i-d} feedback, we provide inner and outer bounds on the capacity-equivocation region, and we find that these bounds meet if the eavesdropper's received symbol Z_i is a degraded version of the legitimate receiver's Y_i .
- Second, inner and outer bounds on the capacity-equivocation region are provided for the model of Figure 2 with both delayed state S_{i-d} and delayed output Y_{i-d} feedback. We also find that these bounds meet if Z_i is a

¹Here the overall wiretap channel is a cascade of the main channel and the wiretap channel

²Here note that Wyner's wiretap channel model is a kind of degraded broadcast channel

³Throughout this paper, the "receiver" is used as a shorthand for "legitimate receiver"

degraded version of Y_i . Moreover, unlike the fact that the delayed receiver's channel output feedback does not increase the capacity of the FSMC with only delayed state feedback [4], we find that for the degraded case, this delayed channel output feedback Y_{i-d} helps to enhance the capacity-equivocation region of the FSM-WC with only delayed state feedback, i.e., sending back the receiver's channel output to the transmitter may help to enhance the security of the practical mobile wireless communication systems.

- The above results are further explained via degraded Gaussian and Gaussian fading examples.

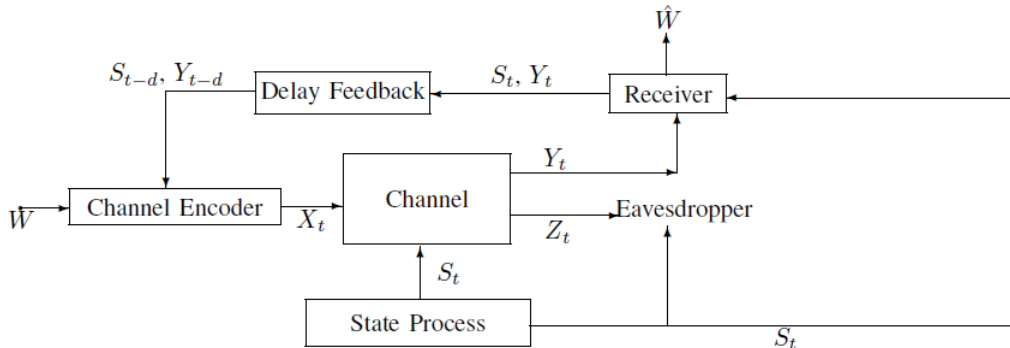

Fig. 2: The FSM-WC with delayed feedback

The rest of this paper is organized as follows. In Section II, we show the definitions, notations and the main results of the model of Figure 2. Degraded Gaussian and Gaussian fading examples of the model of Figure 2 are provided in Section III. Final conclusions are presented in Section IV.

II. BASIC NOTATIONS, DEFINITIONS AND THE MAIN RESULT OF THE MODEL OF FIGURE 2

Basic notations: We use the notation $p_V(v)$ to denote the probability mass function $Pr\{V = v\}$, where V (capital letter) denotes the random variable, v (lower case letter) denotes the real value of the random variable V . Denote the alphabet in which the random variable V takes values by \mathcal{V} (calligraphic letter). Similarly, let U^N be a random vector (U_1, \dots, U_N) , and u^N be a vector value (u_1, \dots, u_N) . In the rest of this paper, the log function is taken to the base 2.

Definitions of the model of Figure 2:

- The channel is a finite-state Markov channel (FSMC), where the channel state S takes values in a finite alphabet $\mathcal{S} = \{s_1, s_2, \dots, s_k\}$. At the i -th time ($1 \leq i \leq N$), the transition probability of the channel depends on the state s_i , the input x_i and the outputs y_i, z_i , and is given by $P_{Y,Z|X,S}(y_i, z_i|x_i, s_i)$. The i -th time outputs of the channel Y_i and Z_i are assumed to depend only on X_i and S_i , and thus we have

$$P_{Y^N, Z^N|X^N, S^N}(y^N, z^N|x^N, s^N) = \prod_{i=1}^N P_{Y,Z|X,S}(y_i, z_i|x_i, s_i). \quad (2.1)$$

- The state process $\{S_i\}$ is assumed to be a stationary irreducible aperiodic ergodic Markov chain. The state process is independent of the transmitted messages, and it is independent of the channel input and outputs given the previous states, i.e.,

$$\Pr\{S_i = s_i | X^i = x^i, Y^i = y^i, S^{i-1} = s^{i-1}\} = \Pr\{S_i = s_i | S_{i-1} = s_{i-1}\}. \quad (2.2)$$

Here note that (2.2) also implies that

$$\Pr\{S_i = s_i | X^i = x^i, Y^i = y^i, S^{i-d} = s^{i-d}\} = \Pr\{S_i = s_i | S_{i-d} = s_{i-d}\}, \quad (2.3)$$

where $1 \leq d \leq i - 1$. Denote the 1-step transition probability matrix by K , and denote the steady state probability of $\{S_i\}$ by π . Let the random variables S_i and S_{i-d} be the channel states at time i and $i - d$, respectively. The joint distribution of (S_i, S_{i-d}) is given by

$$\pi_d(S_i = s_l, S_{i-d} = s_j) = \pi(s_j)K^d(s_j, s_l), \quad (2.4)$$

where s_l is the l -th element of \mathcal{S} , s_j is the j -th element of \mathcal{S} , and $K^d(s_j, s_l)$ is the (j, l) -th element of the d -step transition probability matrix K^d of the Markov process..

- Let W , uniformly distributed over the finite alphabet $\mathcal{W} = \{1, 2, \dots, M\}$, be the message sent by the transmitter. Here note that W is independent of the state process $\{S_i\}$ ($1 \leq i \leq N$) and $H(W) = \log M$. For the model of Figure 2 without receiver's channel output feedback, the i -th time channel input X_i is given by

$$X_i = \begin{cases} f_i(W), & 1 \leq i \leq d \\ f_i(W, S^{i-d}), & d+1 \leq i \leq N. \end{cases} \quad (2.5)$$

and for the model of Figure 2 with receiver's channel output feedback, X_i is given by

$$X_i = \begin{cases} f_i(W), & 1 \leq i \leq d \\ f_i(W, S^{i-d}, Y^{i-d}), & d+1 \leq i \leq N, \end{cases} \quad (2.6)$$

Here note that the i -th time channel encoder f_i is a stochastic encoder.

- The channel decoder is a mapping

$$\psi : \mathcal{Y}^N \times \mathcal{S}^N \rightarrow \{1, 2, \dots, M\}, \quad (2.7)$$

with inputs Y^N, S^N and output \hat{W} . The average probability of error P_e is denoted by

$$P_e = \frac{1}{M} \sum_{i=1}^M \sum_{s^N} P_{S^N}(s^N) \Pr\{\psi(y^N, s^N) \neq i | i \text{ was sent}\}. \quad (2.8)$$

- Since the state is also known by the eavesdropper, the eavesdropper's equivocation to the message W is defined as

$$\Delta = \frac{1}{N} H(W | Z^N, S^N). \quad (2.9)$$

- A rate pair (R, R_e) (where $R, R_e > 0$) is called achievable if, for any $\epsilon > 0$, there exists a channel encoder-decoder (N, Δ, P_e) such that

$$\frac{\log M}{N} \geq R - \epsilon, \quad \Delta \geq R_e - \epsilon, \quad P_e \leq \epsilon. \quad (2.10)$$

The capacity-equivocation region is a set composed of all achievable (R, R_e) pairs. Here the capacity-equivocation region of the model of Figure 2 with only delayed state feedback is denoted by \mathcal{R} , and \mathcal{R}^f denotes the capacity-equivocation region of the model of Figure 2 with delayed state and receiver's channel output feedback. In the remainder of this section, the bounds on the capacity-equivocation region \mathcal{R} are given in Theorem 1 and Theorem 2, and the bounds on \mathcal{R}^f are given in Theorem 3 and Theorem 4, see the followings.

Main results on \mathcal{R} :

Theorem 1: An inner bound \mathcal{R}^{in} on \mathcal{R} is given by

$$\begin{aligned}\mathcal{R}^{in} &= \{(R, R_e) : 0 \leq R_e \leq R, \\ R &\leq I(V; Y|S, \tilde{S}), \\ R_e &\leq I(V; Y|U, S, \tilde{S}) - I(V; Z|U, S, \tilde{S})\},\end{aligned}$$

where the joint probability $P_{UVS\tilde{S}XYZ}(u, v, s, \tilde{s}, x, y, z)$ satisfies

$$\begin{aligned}P_{UVS\tilde{S}XYZ}(u, v, s, \tilde{s}, x, y, z) \\ &= P_{YZ|XS}(y, z|x, s)P_{X|UV\tilde{S}}(x|u, v, \tilde{s})P_{V|U\tilde{S}}(v|u, \tilde{s}) \cdot \\ &P_{U|\tilde{S}}(u|\tilde{s})K^d(\tilde{s}, s)P_{\tilde{S}}(\tilde{s}),\end{aligned}\tag{2.11}$$

and U may be assumed to be a (deterministic) function of V .

Proof: The transmitted message W is split into two part: a common message represented by the auxiliary random variable U and a confidential message represented by the auxiliary random variable V . Moreover, the delayed feedback state S_{i-d} is represented by the auxiliary random variable \tilde{S} . Theorem 1 is proved by combining the rate splitting technique, Wyner's random binning technique [11] with the multiplexing coding scheme for the finite state Markov channel (FSMC) with state feedback [4]. The details of the proof are in Appendix A. ■

Theorem 2: An outer bound \mathcal{R}^{out} on \mathcal{R} is given by

$$\begin{aligned}\mathcal{R}^{out} &= \{(R, R_e) : 0 \leq R_e \leq R, \\ R &\leq I(V; Y|S, \tilde{S}), \\ R_e &\leq I(V; Y|U, S, \tilde{S}) - I(V; Z|U, S, \tilde{S})\},\end{aligned}$$

where the joint probability $P_{UVS\tilde{S}XYZ}(u, v, s, \tilde{s}, x, y, z)$ satisfies

$$\begin{aligned}P_{UVS\tilde{S}XYZ}(u, v, s, \tilde{s}, x, y, z) \\ &= P_{YZ|XS}(y, z|x, s)P_{XVUS\tilde{S}}(x, v, u, s, \tilde{s}).\end{aligned}\tag{2.12}$$

Proof: Theorem 2 is proved by introducing the delayed feedback state S_{i-d} into the converse proof of the broadcast channel with confidential messages [13], see Appendix B. ■

Remark 1: There are some notes on Theorem 1 and Theorem 2, see the followings.

- Here note that the inner bound \mathcal{R}^{in} is almost the same as the outer bound \mathcal{R}^{out} , except the definitions of the joint probability $P_{UVS\tilde{S}XYZ}(u, v, s, \tilde{s}, x, y, z)$ in \mathcal{R}^{in} and \mathcal{R}^{out} . To be specific, in \mathcal{R}^{in} , the definition of $P_{UVS\tilde{S}XYZ}(u, v, s, \tilde{s}, x, y, z)$ implies the Markov chains $S \rightarrow (\tilde{S}, U, V) \rightarrow X$, $S \rightarrow (\tilde{S}, U) \rightarrow V$ and $S \rightarrow \tilde{S} \rightarrow U$, but these chains are not guaranteed in \mathcal{R}^{out} .
- If the eavesdropper's received symbol Z^N is a degraded version of Y^N , i.e., the Markov chain $(X^N, S^N) \rightarrow Y^N \rightarrow Z^N$ holds, the outer bound \mathcal{R}^{out} meets with the inner bound \mathcal{R}^{in} , and they reduce to the following region \mathcal{R}^* , where

$$\begin{aligned}\mathcal{R}^* &= \{(R, R_e) : R_e \leq R, \\ R &\leq I(X; Y|S, \tilde{S}), \\ R_e &\leq I(X; Y|S, \tilde{S}) - I(X; Z|S, \tilde{S})\},\end{aligned}\tag{2.13}$$

and the joint probability $P_{S\tilde{S}XYZ}(s\tilde{s}xyz)$ satisfies

$$P_{S\tilde{S}XYZ}(s\tilde{s}xyz) = P_{Z|Y}(z|y)P_{Y|X,S}(y|x, s)K^d(\tilde{s}, s)P_{X|\tilde{S}}(x|\tilde{s})P_{\tilde{S}}(\tilde{s}).\tag{2.14}$$

Proof: See Appendix C. ■

- A rate R is called achievable with weak secrecy if, for any $\epsilon > 0$, there exists a channel encoder-decoder (N, Δ, P_e) such that

$$\frac{\log M}{N} \geq R - \epsilon, \quad \Delta \geq R - \epsilon, \quad P_e \leq \epsilon.\tag{2.15}$$

The secrecy capacity is the maximum achievable rate with weak secrecy, and it can be directly obtained by substituting $R_e = R$ into the corresponding capacity-equivocation region and maximizing R . Thus, for the degraded case of the model of Figure 2 with only delayed state feedback, the secrecy capacity C_s^* is given by

$$C_s^* = \max_{P_{X|\tilde{S}}(x|\tilde{s})} (I(X; Y|S, \tilde{S}) - I(X; Z|S, \tilde{S})).\tag{2.16}$$

Here C_s^* is obtained by substituting $R_e = R$ into (2.13) and maximizing R .

Main results on \mathcal{R}^f :

Theorem 3: An inner bound \mathcal{R}^{fi} on the capacity-equivocation region \mathcal{R}^f is given by

$$\begin{aligned}\mathcal{R}^{fi} &= \{(R, R_e) : 0 \leq R_e \leq R, \\ R &\leq I(V; Y|S, \tilde{S}), \\ R_e &\leq [I(V; Y|U, S, \tilde{S}) - I(V; Z|U, S, \tilde{S})]^+ + H(Y|V, Z, S, \tilde{S})\},\end{aligned}$$

where $[x]^+ = x$ if $x > 0$, $[x]^+ = 0$ if $x \leq 0$, the joint probability mass function $P_{UVS\tilde{S}XYZ}(u, v, s, \tilde{s}, x, y, z)$ satisfies

$$\begin{aligned}&P_{UVS\tilde{S}XYZ}(u, v, s, \tilde{s}, x, y, z) \\ &= P_{YZ|XS}(y, z|x, s)P_{X|UV\tilde{S}}(x|u, v, \tilde{s})P_{V|U\tilde{S}}(v|u, \tilde{s}) \cdot \\ &P_{U|\tilde{S}}(u|\tilde{s})K^d(\tilde{s}, s)P_{\tilde{S}}(\tilde{s}),\end{aligned}\tag{2.17}$$

and U may be assumed to be a (deterministic) function of V .

Proof: Similar to the construction of the inner bound \mathcal{R}^{in} on the capacity-equivocation region \mathcal{R} , the transmitted message W is split into a common message represented by the auxiliary random variable U and a confidential message represented by the auxiliary random variable V . The inner bound \mathcal{R}^{fi} is constructed according to a multiplexing double binning coding scheme with a secret key, where the secret key is generated by the delayed receiver's channel output feedback. The details are in Appendix D. ■

Theorem 4: An outer bound \mathcal{R}^{fo} on the capacity-equivocation region \mathcal{R}^f is given by

$$\begin{aligned}\mathcal{R}^{fo} &= \{(R, R_e) : 0 \leq R_e \leq R, \\ R &\leq I(V; Y|S, \tilde{S}), \\ R_e &\leq H(Y|Z, U, S, \tilde{S})\},\end{aligned}$$

where the joint probability mass function $P_{UVS\tilde{S}XYZ}(u, v, s, \tilde{s}, x, y, z)$ satisfies

$$P_{UVS\tilde{S}XYZ}(u, v, s, \tilde{s}, x, y, z) = P_{YZ|XS}(y, z|x, s)P_{XVUS\tilde{S}}(x, v, u, s, \tilde{s}). \quad (2.18)$$

and U may be assumed to be a (deterministic) function of V .

Proof: See Appendix E. ■

Remark 2: There are some notes on Theorem 3 and Theorem 4, see the followings.

- Comparing \mathcal{R}^{fi} with \mathcal{R}^{in} , it is easy to see that the delayed receiver's channel output feedback helps to enhance the achievable rate-equivocation region of the FSM-WC with only delayed state feedback.
- If the eavesdropper's received symbol Z^N is a degraded version of Y^N , i.e., the Markov chain $(X^N, S^N) \rightarrow Y^N \rightarrow Z^N$ holds, the outer bound \mathcal{R}^{fo} meets with the inner bound \mathcal{R}^{fi} , and they reduce to the following region \mathcal{R}^{f*} , where

$$\begin{aligned}\mathcal{R}^{f*} &= \{(R, R_e) : R_e \leq R, \\ R &\leq I(X; Y|S, \tilde{S}), \\ R_e &\leq H(Y|Z, S, \tilde{S})\},\end{aligned} \quad (2.19)$$

and the joint probability $P_{S\tilde{S}XYZ}(s\tilde{s}xyz)$ satisfies

$$P_{S\tilde{S}XYZ}(s\tilde{s}xyz) = P_{Z|Y}(z|y)P_{Y|X,S}(y|x, s)K^d(\tilde{s}, s)P_{X|\tilde{S}}(x|\tilde{s})P_{\tilde{S}}(\tilde{s}). \quad (2.20)$$

Proof: See Appendix F. ■

- For the degraded case of the model of Figure 2 with delayed state and receiver's channel output feedback, the secrecy capacity \mathcal{C}_s^{*f} can be directly obtained from the above \mathcal{R}^{f*} , and it is given by

$$\mathcal{C}_s^{*f} = \max_{P_{X|\tilde{S}}(x|\tilde{s})} \min\{I(X; Y|S, \tilde{S}), H(Y|Z, S, \tilde{S})\}. \quad (2.21)$$

Note that (2.21) can also be re-written as

$$\mathcal{C}_s^{*f} = \max_{P_{X|\tilde{S}}(x|\tilde{s})} \min\{I(X; Y|S, \tilde{S}), I(X; Y|S, \tilde{S}) - I(X; Z|S, \tilde{S}) + H(Y|X, Z, S, \tilde{S})\}, \quad (2.22)$$

and this is because

$$\begin{aligned}
& I(X; Y|S, \tilde{S}) - I(X; Z|S, \tilde{S}) + H(Y|X, Z, S, \tilde{S}) = -H(X|S, \tilde{S}, Y) + H(X|S, \tilde{S}, Z) + H(Y|X, Z, S, \tilde{S}) \\
& \stackrel{(1)}{=} -H(X|S, \tilde{S}, Y, Z) + H(X|S, \tilde{S}, Z) + H(Y|X, Z, S, \tilde{S}) \\
& = I(X; Y|S, \tilde{S}, Z) + H(Y|X, Z, S, \tilde{S}) \\
& = H(Y|S, \tilde{S}, Z),
\end{aligned} \tag{2.23}$$

where (1) is from the Markov chain $X \rightarrow (S, \tilde{S}, Y) \rightarrow Z$. Comparing (2.22) with (2.16), it is easy to see that the delayed receiver's channel output feedback helps to enhance the secrecy capacity of the degraded FSM-WC with only delayed state feedback.

III. EXAMPLES

A. Secrecy Capacity for the Degraded Gaussian Case of the model of Figure 2 with or without Delayed Receiver's Channel Output Feedback

In this subsection, we compute the secrecy capacities for the degraded Gaussian case of Figure 2 with or without delayed receiver's channel output feedback, and investigate how this delayed feedback and channel memory affect the secrecy capacities. At the i -th time ($1 \leq i \leq N$), the inputs and outputs of the channel satisfy

$$Y_i = X_i + N_{S_i}, \quad Z_i = Y_i + N_{w,i}. \tag{3.24}$$

Here note that N_{S_i} is Gaussian distributed with zero mean, and the variance depends on the i -th time state $S_i = s_i$ (denoted by $\sigma_{s_i}^2$). The random variable $N_{w,i}$ ($1 \leq i \leq N$) is also Gaussian distributed with zero mean and constant variance σ_w^2 ($N_{w,i} \sim \mathcal{N}(0, \sigma_w^2)$ for all $i \in \{1, 2, \dots, N\}$). At time i , the receiver has access to the state S_i and the output Y_i . The state S_i is fed back to the transmitter through a noiseless feedback channel with a delay time d . The state undergoes a Markov process with steady probability distribution $\pi(s)$ and 1-step transition probability matrix K . The power constraint of the transmitter is given by

$$\sum_{\tilde{s}} \pi(\tilde{s}) E_{P_{X|\tilde{s}}(x|\tilde{s})} [X^2|\tilde{s}] \leq \mathcal{P}_0. \tag{3.25}$$

Secrecy capacity for the degraded Gaussian case of the model of Figure 2 with only delayed state feedback:

For the degraded Gaussian case of the model of Figure 2 with only delayed state feedback, the secrecy capacity $C_s^{(g)}$ is given by

$$C_s^{(g)} = \max_{\mathcal{P}(\tilde{s}): \sum_{\tilde{s}} \pi(\tilde{s}) \mathcal{P}(\tilde{s}) \leq \mathcal{P}_0} \sum_{\tilde{s}} \sum_s \pi(\tilde{s}) K^d(\tilde{s}, s) \left(\frac{1}{2} \log \left(1 + \frac{\mathcal{P}(\tilde{s})}{\sigma_s^2} \right) - \frac{1}{2} \log \left(1 + \frac{\mathcal{P}(\tilde{s})}{\sigma_s^2 + \sigma_w^2} \right) \right), \tag{3.26}$$

where $\mathcal{P}(\tilde{s})$ is the transmitter's power for the state \tilde{s} , and σ_s^2 is the variance of the noise N_S given the state $S = s$. These definitions are similar to those in [4, pp. 764-765].

Proof:

(Converse part:) Using (2.16), the secrecy capacity $C_s^{(g)}$ can be re-written by

$$C_s^{(g)} = \max_{P_{X|\tilde{s}}(x|\tilde{s})} \sum_{\tilde{s}} \pi(\tilde{s}) \sum_s K^d(\tilde{s}, s) (I(X; Y|S = s, \tilde{S} = \tilde{s}) - I(X; Z|S = s, \tilde{S} = \tilde{s})). \tag{3.27}$$

Letting $\mathcal{P}(\tilde{s})$ be the transmitter's power for the state \tilde{s} satisfying (3.25), and σ_s^2 be the variance of the noise N_S given the state $S = s$, then we have

$$\begin{aligned}
& I(X; Y|S = s, \tilde{S} = \tilde{s}) - I(X; Z|S = s, \tilde{S} = \tilde{s}) \\
&= h(Y|S = s, \tilde{S} = \tilde{s}) - h(Y|X, S = s, \tilde{S} = \tilde{s}) - h(Z|S = s, \tilde{S} = \tilde{s}) + h(Z|X, S = s, \tilde{S} = \tilde{s}) \\
&= h(X_{\tilde{s}} + N_s) - h(N_s) - h(X_{\tilde{s}} + N_s + N_w) + h(N_s + N_w) \\
&\stackrel{(a)}{\leq} h(X_{\tilde{s}} + N_s) - h(N_s) - \frac{1}{2} \log(2^{2h(X_{\tilde{s}} + N_s)} + 2^{2h(N_w)}) + h(N_s + N_w) \\
&\stackrel{(b)}{\leq} \frac{1}{2} \log\left(1 + \frac{\mathcal{P}(\tilde{s})}{\sigma_s^2}\right) - \frac{1}{2} \log\left(1 + \frac{\mathcal{P}(\tilde{s})}{\sigma_s^2 + \sigma_w^2}\right), \tag{3.28}
\end{aligned}$$

where (a) is from the entropy power inequality, (b) is from $h(X_{\tilde{s}} + N_s) - \frac{1}{2} \log(2^{2h(X_{\tilde{s}} + N_s)} + 2^{2h(N_w)})$ is increasing while $h(X_{\tilde{s}} + N_s)$ is increasing, and the fact that for a given variance, the largest entropy is achieved if the random variable is Gaussian distributed. Furthermore, the “=” in (a) is achieved if $X_{\tilde{s}} \sim \mathcal{N}(0, \mathcal{P}(\tilde{s}))$ and $X_{\tilde{s}}$ is independent of N_s . Applying (3.28) to (3.27), the converse part of (3.26) is proved.

(*Direct part:*) Letting $X_{\tilde{s}}$ be the random variable X given the delayed state \tilde{s} , and substituting $X_{\tilde{s}} \sim \mathcal{N}(0, \mathcal{P}(\tilde{s}))$ and (3.24) into (3.27), the achievability proof of (3.26) is along the lines of that of (2.16) (see Appendix C), and thus we omit the proof here.

The proof of (3.26) is completed. ■

Secrecy capacity for the degraded Gaussian case of the model of Figure 2 with delayed state and receiver's channel output feedback:

For the degraded Gaussian case of the model of Figure 2 with delayed state and receiver's channel output feedback, the secrecy capacity $C_s^{(gf)}$ is given by

$$C_s^{(gf)} = \max_{\mathcal{P}(\tilde{s}): \sum_{\tilde{s}} \pi(\tilde{s}) \mathcal{P}(\tilde{s}) \leq \mathcal{P}_0} \sum_{\tilde{s}} \sum_s \pi(\tilde{s}) K^d(\tilde{s}, s) \min\left\{\frac{1}{2} \log\left(1 + \frac{\mathcal{P}(\tilde{s})}{\sigma_s^2}\right), \frac{1}{2} \log \frac{2\pi e \sigma_w^2 (\mathcal{P}(\tilde{s}) + \sigma_s^2)}{\mathcal{P}(\tilde{s}) + \sigma_s^2 + \sigma_w^2}\right\}. \tag{3.29}$$

Proof: Defining $\mathcal{P}(\tilde{s})$ as the transmitter's power for the state \tilde{s} , the secrecy capacity C_s^{*f} in (2.21) can be re-written as

$$C_s^{*f} = \max_{\mathcal{P}(\tilde{s}): \sum_{\tilde{s}} \pi(\tilde{s}) \mathcal{P}(\tilde{s}) \leq \mathcal{P}_0} \sum_{\tilde{s}} \sum_s \pi(\tilde{s}) K^d(\tilde{s}, s) \min\{I(X; Y|S = s, \tilde{S} = \tilde{s}), H(Y|Z, S = s, \tilde{S} = \tilde{s})\}. \tag{3.30}$$

(*Converse part:*) Defining σ_s^2 as the variance of the noise N_S given the state $S = s$, the mutual information $I(X; Y|S = s, \tilde{S} = \tilde{s})$ in (3.30) can be further bounded by

$$\begin{aligned}
I(X; Y|S = s, \tilde{S} = \tilde{s}) &= h(Y|S = s, \tilde{S} = \tilde{s}) - h(Y|S = s, \tilde{S} = \tilde{s}, X) \\
&\leq h(X_{\tilde{s}} + N_s) - h(Y|S = s, \tilde{S} = \tilde{s}, X) \\
&= h(X_{\tilde{s}} + N_s) - h(N_s) \\
&\stackrel{(a)}{\leq} \frac{1}{2} \log\left(1 + \frac{\mathcal{P}(\tilde{s})}{\sigma_s^2}\right), \tag{3.31}
\end{aligned}$$

where (a) is from the fact that for a given variance, the largest entropy is achieved if the random variable is Gaussian distributed.

Moreover, the differential conditional entropy $h(Y|Z, S = s, \tilde{S} = \tilde{s})$ can be further bounded by

$$\begin{aligned}
h(Y|Z, S = s, \tilde{S} = \tilde{s}) &= h(Y, Z, S = s, \tilde{S} = \tilde{s}) - h(Z, S = s, \tilde{S} = \tilde{s}) \\
&\stackrel{(b)}{=} h(Z|Y) + h(Y, S = s, \tilde{S} = \tilde{s}) - h(Z, S = s, \tilde{S} = \tilde{s}) \\
&= h(Z|Y) + h(Y|S = s, \tilde{S} = \tilde{s}) - h(Z|S = s, \tilde{S} = \tilde{s}) \\
&\stackrel{(c)}{=} h(N_w) + h(Y|S = s, \tilde{S} = \tilde{s}) - h(Y + N_w|S = s, \tilde{S} = \tilde{s}) \\
&\stackrel{(d)}{\leq} h(N_w) + h(Y|S = s, \tilde{S} = \tilde{s}) - \frac{1}{2} \log(2^{2h(Y|S=s, \tilde{S}=\tilde{s})} + 2^{2h(N_w)}) \\
&= \frac{1}{2} \log(2\pi e\sigma_w^2) + h(Y|S = s, \tilde{S} = \tilde{s}) - \frac{1}{2} \log(2^{2h(Y|S=s, \tilde{S}=\tilde{s})} + 2\pi e\sigma_w^2) \\
&\stackrel{(e)}{\leq} \frac{1}{2} \log(2\pi e\sigma_w^2) + \frac{1}{2} \log(2\pi e(\mathcal{P}(\tilde{s}) + \sigma_s^2)) - \frac{1}{2} \log(2\pi e(\mathcal{P}(\tilde{s}) + \sigma_s^2 + \sigma_w^2)) \\
&= \frac{1}{2} \log \frac{2\pi e\sigma_w^2(\mathcal{P}(\tilde{s}) + \sigma_s^2)}{\mathcal{P}(\tilde{s}) + \sigma_s^2 + \sigma_w^2}, \tag{3.32}
\end{aligned}$$

where (b) is from the Markov chain $(S, \tilde{S}) \rightarrow Y \rightarrow Z$, (c) is from the fact that $Z = Y + N_w$, (d) is from the entropy power inequality, and (e) is from the fact that $h(Y|S = s, \tilde{S} = \tilde{s}) - \frac{1}{2} \log(2^{2h(Y|S=s, \tilde{S}=\tilde{s})} + 2\pi e\sigma_w^2)$ is increasing while $h(Y|S = s, \tilde{S} = \tilde{s})$ is increasing, and

$$h(Y|S = s, \tilde{S} = \tilde{s}) \leq h(X_{\tilde{s}} + N_s) \leq \frac{1}{2} \log(2\pi e(\mathcal{P}(\tilde{s}) + \sigma_s^2)). \tag{3.33}$$

Applying (3.31) and (3.32) to (3.30), the converse proof of (3.29) is completed.

(Direct part:) Letting $X_{\tilde{s}}$ be the random variable X given the delayed state \tilde{s} , and substituting $X_{\tilde{s}} \sim \mathcal{N}(0, \mathcal{P}(\tilde{s}))$ and (3.24) into (3.30), the achievability proof of (3.29) is along the lines of that of Theorem 3, and thus we omit the details here.

The proof of (3.29) is completed. ■

Numerical results of (3.26) and (3.29)

In order to gain some intuition on the secrecy capacities of (3.26) and (3.29), we consider a simple case that the state alphabet \mathcal{S} is composed of only two elements. At each time instant, the state of the channel is G (good state) or B (bad state). For the state G , the noise variance of the channel is σ_G^2 . Analogously, for the state B , the noise variance of the channel is σ_B^2 . Here note that $\sigma_B^2 > \sigma_G^2$. The state process is shown in Figure 3, where

$$P(G|G) = 1 - b, \quad P(B|G) = b, \quad P(B|B) = 1 - g, \quad P(G|B) = g. \tag{3.34}$$

The steady state probabilities $\pi(G)$ and $\pi(B)$ are given by

$$\pi(G) = \frac{g}{g+b}, \quad \pi(B) = \frac{b}{g+b}. \tag{3.35}$$

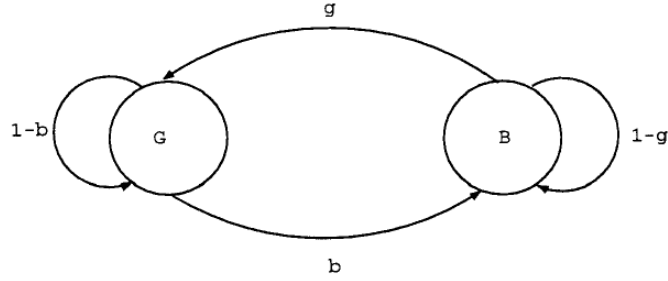
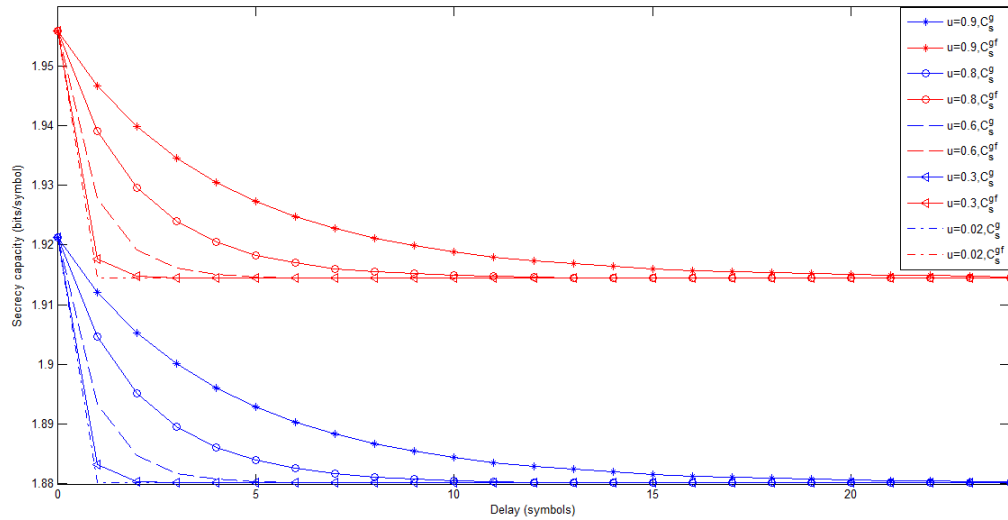

Fig. 3: The state process of the two-state case

Fig. 4: The secrecy capacities $C_s^{(g)}$ and $C_s^{(gf)}$ for $\mathcal{P}_0 = 100$, $\sigma_G^2 = 1$, $\sigma_B^2 = 100$, $\sigma_w^2 = 2000$, $c = 1$ and several values of u

Define $u = 1 - g - b$ and $c = g/b$. The parameter u is related to the channel memory,⁴ and the parameter c controls the steady state distributions (see 3.35). Fixing c (for example, $c = 1$), we can choose different u and d to investigate the effects of channel memory and feedback delay on the secrecy capacities $C_s^{(g)}$ and $C_s^{(gf)}$. Figure 4 and Figure 5 show the effect of the feedback delay on the secrecy capacities for $\mathcal{P}_0 = 100$, $\sigma_G^2 = 1$, $\sigma_B^2 = 100$, $\sigma_w^2 = 2000$ ($\sigma_w^2 = 100$), $c = 1$ and several values of u . As we can see in Figure 4 and Figure 5, when the channel is changing rapidly (which implies that the channel memory u is small, for example, $u = 0.02$), the secrecy capacity goes to the infinite asymptote even if $d = 1$. However, when the channel is changing slowly (which implies that the channel memory u is large, for example, $u = 0.9$), a larger feedback delay is tolerable since the secrecy capacity loss compared with feedback without delay ($d = 0$) is smaller. Moreover, it is easy to see that the delayed receiver's

⁴Mushkin and Bar-David [38] has already shown that the channel memory is increasing while u is increasing.

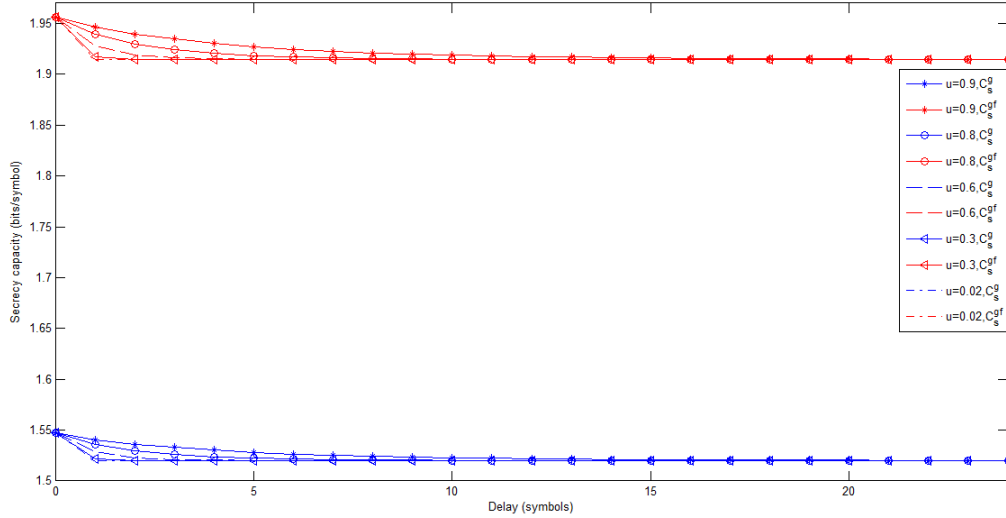

Fig. 5: The secrecy capacities $C_s^{(g)}$ and $C_s^{(gf)}$ for $\mathcal{P}_0 = 100$, $\sigma_G^2 = 1$, $\sigma_B^2 = 100$, $\sigma_w^2 = 100$, $c = 1$ and several values of u

channel output feedback enhances the secrecy capacity $C_s^{(g)}$ of the degraded Gaussian case of the FSM-WC with only delayed state feedback. Furthermore, comparing these two figures, we can see that for fixed \mathcal{P}_0 , σ_G^2 , σ_B^2 and c , the gap between $C_s^{(g)}$ and $C_s^{(gf)}$ is increasing while σ_w^2 is decreasing.

B. Secrecy Capacity for the Degraded Gaussian Fading Case of Figure 2

In this subsection, we compute the secrecy capacities for the degraded Gaussian fading case of Figure 2. At the i -th time ($1 \leq i \leq N$), the inputs and the outputs of the channel satisfy

$$Y_i = g(s_i)X_i + N_{S_i}, \quad Z_i = l_i Y_i + N_{w,i}. \quad (3.36)$$

Here $g(s_i)$ is the fading process of the transmitter, and it is a deterministic function of s_i . The noise N_{S_i} is Gaussian distributed with zero mean, and the variance depends on the i -th time state S_i of the channel. For the eavesdropper, the fading coefficient l_i is a constant, i.e., $l_i = l$ for all $i \in \{1, 2, \dots, N\}$. The random variable $N_{w,i}$ ($1 \leq i \leq N$) is also Gaussian distributed with zero mean and constant variance σ_w^2 ($N_{w,i} \sim \mathcal{N}(0, \sigma_w^2)$ for all $i \in \{1, 2, \dots, N\}$). Now we apply (2.16) to determine the secrecy capacities of this degraded Gaussian fading model with or without delayed receiver's channel output feedback, see the remainder of this subsection.

Secrecy capacity for the degraded Gaussian fading case of the model of Figure 2 with only delayed state feedback:

Similar to Subsection III-A, let $\mathcal{P}(\tilde{s})$ be the power for the state \tilde{s} , and σ_s^2 be the variance of the noise N_S given

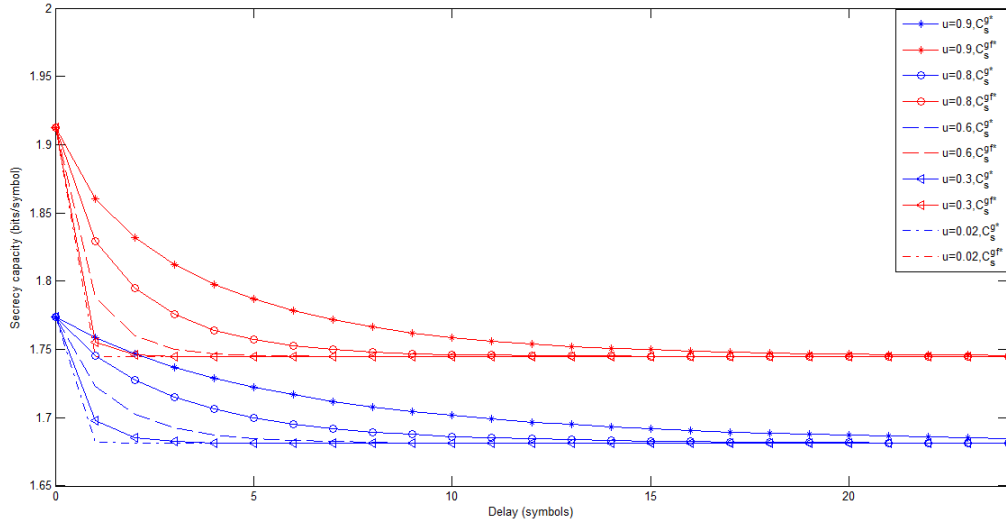

Fig. 6: The secrecy capacities $C_s^{(g^*)}$ and $C_s^{(gf^*)}$ for $\mathcal{P}_0 = 100$, $\sigma_G^2 = 1$, $\sigma_B^2 = 100$, $\sigma_w^2 = 200$, $c = 1$, $g(G) = 1$, $g(B) = 0.5$, $l = 0.8$ and several values of u

$S = s$, and thus we have

$$\begin{aligned}
& I(X; Y|S = s, \tilde{S} = \tilde{s}) - I(X; Z|S = s, \tilde{S} = \tilde{s}) \\
&= h(Y|S = s, \tilde{S} = \tilde{s}) - h(Y|X, S = s, \tilde{S} = \tilde{s}) - h(Z|S = s, \tilde{S} = \tilde{s}) + h(Z|X, S = s, \tilde{S} = \tilde{s}) \\
&= h(g(s)X_{\tilde{s}} + N_s) - h(N_s) - h(l(g(s)X_{\tilde{s}} + N_s) + N_w) + h(lN_s + N_w) \\
&\stackrel{(a)}{\leq} h(g(s)X_{\tilde{s}} + N_s) - h(N_s) - \frac{1}{2} \log(2^{2h(g(s)X_{\tilde{s}} + N_s)} l^2 + 2^{2h(N_w)}) + h(lN_s + N_w) \\
&\stackrel{(b)}{\leq} \frac{1}{2} \log\left(1 + \frac{g^2(s)\mathcal{P}(\tilde{s})}{\sigma_s^2}\right) - \frac{1}{2} \log\left(1 + \frac{g^2(s)l^2\mathcal{P}(\tilde{s})}{l^2\sigma_s^2 + \sigma_w^2}\right), \tag{3.37}
\end{aligned}$$

where (a) is from the entropy power inequality and the property that $h(aX) = h(X) + \log a$, and (b) is from $h(g(s)X_{\tilde{s}} + N_s) - \frac{1}{2} \log(2^{2h(g(s)X_{\tilde{s}} + N_s)} l^2 + 2^{2h(N_w)})$ is increasing while $h(g(s)X_{\tilde{s}} + N_s)$ is increasing, and the fact that for a given variance, the largest entropy is achieved if the random variable is Gaussian distributed. Furthermore, the “=” in (a) is achieved if $X_{\tilde{s}} \sim \mathcal{N}(0, \mathcal{P}(\tilde{s}))$ and $X_{\tilde{s}}$ is independent of N_s .

Applying (3.37) to (3.27), the secrecy capacity $C_s^{(g^*)}$ of the degraded Gaussian fading FSM-WC with delayed state feedback is given by

$$C_s^{(g^*)} = \max_{\mathcal{P}(\tilde{s}): \sum_{\tilde{s}} \pi(\tilde{s})\mathcal{P}(\tilde{s}) \leq \mathcal{P}_0} \frac{1}{2} \sum_{\tilde{s}} \sum_s \pi(\tilde{s}) K^d(\tilde{s}, s) \left(\frac{1}{2} \log\left(1 + \frac{g^2(s)\mathcal{P}(\tilde{s})}{\sigma_s^2}\right) - \frac{1}{2} \log\left(1 + \frac{g^2(s)l^2\mathcal{P}(\tilde{s})}{l^2\sigma_s^2 + \sigma_w^2}\right) \right). \tag{3.38}$$

Here note that replacing X_i by $g(s_i)X_i$, and Y_i by $l_i Y_i$, the achievability proof of (3.38) is along the lines of that of (3.26), and thus we omit the proof here.

Secrecy capacity for the degraded Gaussian fading case of the model of Figure 2 with delayed state and receiver’s channel output feedback:

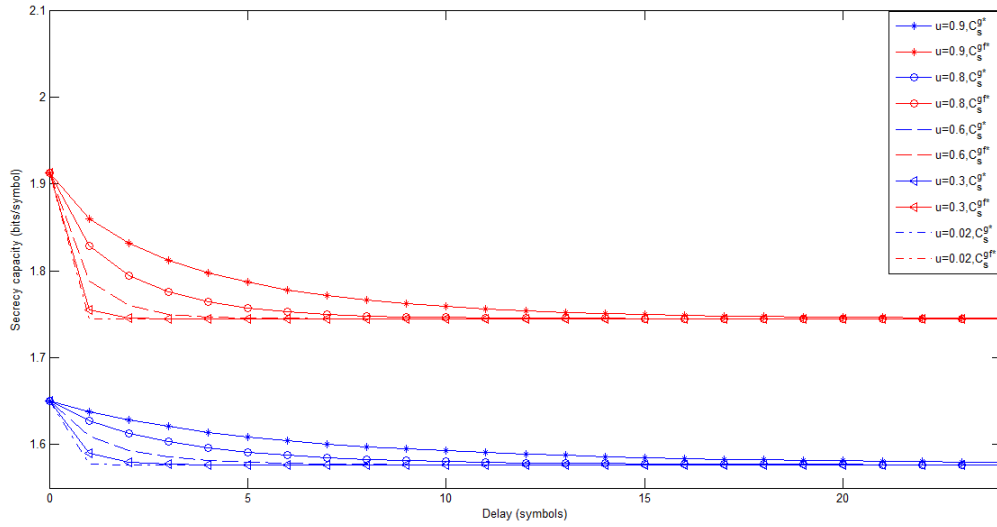

Fig. 7: The secrecy capacities $C_s^{(g^*)}$ and $C_s^{(gf^*)}$ for $\mathcal{P}_0 = 100$, $\sigma_G^2 = 1$, $\sigma_B^2 = 100$, $\sigma_w^2 = 100$, $c = 1$, $g(G) = 1$, $g(B) = 0.5$, $l = 0.8$ and several values of u

For the degraded Gaussian fading case of the model of Figure 2 with delayed state and receiver's channel output feedback, the secrecy capacity $C_s^{(gf^*)}$ is given by

$$C_s^{(gf^*)} = \max_{\mathcal{P}(\tilde{s}); \sum_{\tilde{s}} \pi(\tilde{s}) \mathcal{P}(\tilde{s}) \leq \mathcal{P}_0} \sum_{\tilde{s}} \sum_s \pi(\tilde{s}) K^d(\tilde{s}, s) \min \left\{ \frac{1}{2} \log \left(1 + \frac{g^2(s) \mathcal{P}(\tilde{s})}{\sigma_s^2} \right), \frac{1}{2} \log \frac{2\pi e \sigma_w^2 (g^2(s) \mathcal{P}(\tilde{s}) + \sigma_s^2)}{g^2(s) l^2 \mathcal{P}(\tilde{s}) + l^2 \sigma_s^2 + \sigma_w^2} \right\}. \quad (3.39)$$

Proof: Replacing X_i by $g(s_i)X_i$, and Y_i by $l_i Y_i$, the proof of (3.39) is along the lines of that of (3.29), and thus we omit the proof here. ■

Numerical results of (3.38) and (3.39)

We consider a simple two-state case where the state process is the same as that in Subsection III-A, see Figure 3. Define $g(G) = 1$, $g(B) = 0.5$, $l = 0.8$, $u = 1 - g - b$ and $c = g/b$. By choosing $c = 1$, Figure 6 and Figure 7 show the effect of the feedback delay (d) and channel memory (u) on the secrecy capacities $C_s^{(g^*)}$ and $C_s^{(gf^*)}$ for $\mathcal{P}_0 = 100$, $\sigma_G^2 = 1$, $\sigma_B^2 = 100$, $\sigma_w^2 = 200$ ($\sigma_w^2 = 100$) and several values of u . Similar to the numerical result of Subsection III-A, we find that when the channel is changing rapidly (which implies that the channel memory u is small, for example, $u = 0.02$), the secrecy capacity goes to the infinite asymptote even if $d = 1$. However, when the channel is changing slowly (which implies that the channel memory u is large, for example, $u = 0.9$), a larger feedback delay is tolerable since the secrecy capacity loss compared with feedback without delay ($d = 0$) is smaller. Moreover, it is easy to see that the delayed receiver's channel output feedback enhances the secrecy capacity $C_s^{(g^*)}$ of the degraded Gaussian fading case of the FSM-WC with only delayed state feedback. Furthermore, comparing these two figures, we can see that for fixed \mathcal{P}_0 , σ_G^2 , σ_B^2 and c , the gap between $C_s^{(g^*)}$ and $C_s^{(gf^*)}$ is increasing while σ_w^2 is decreasing.

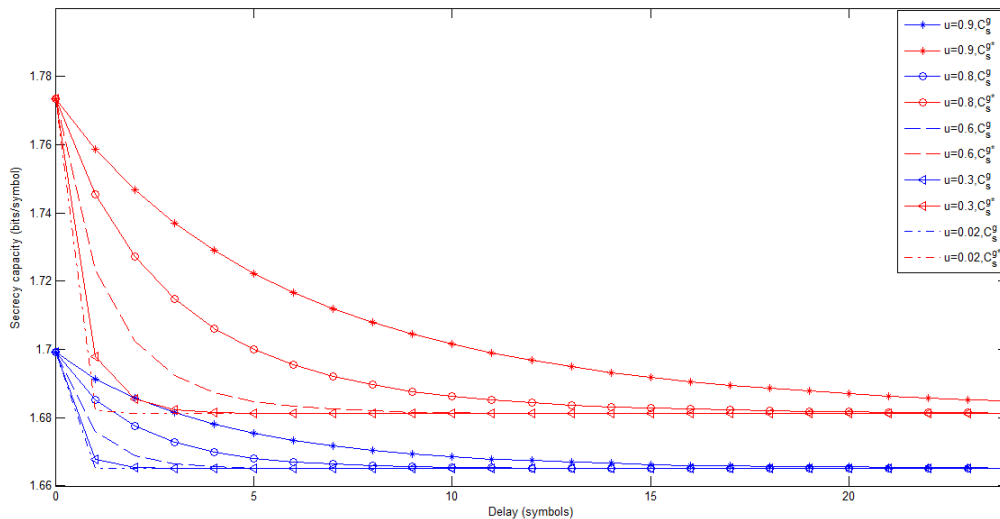

Fig. 8: The comparison of the secrecy capacities $C_s^{(g^*)}$ and $C_s^{(g)}$ for $\mathcal{P}_0 = 100$, $\sigma_G^2 = 1$, $\sigma_B^2 = 100$, $\sigma_w^2 = 200$, $c = 1$, $g(G) = 1$, $g(B) = 0.5$, $l = 0.8$ and several values of u

Moreover, we compare the secrecy capacities for the fading and no-fading cases, see the following Figure 8 to Figure 11. In Figure 8 and Figure 9, we see that $C_s^{(g^*)}$ dominates $C_s^{(g)}$ (which implies that the fading may enhance the security of the degraded Gaussian model of Figure 2 with only delayed state feedback), and the gap between $C_s^{(g^*)}$ and $C_s^{(g)}$ is increasing while σ_w^2 is decreasing.

In Figure 10 and Figure 11, we see that $C_s^{(gf)}$ dominates $C_s^{(gf^*)}$ (which implies that the fading may weaken the security of the degraded Gaussian model of Figure 2 with delayed state and receiver's channel output feedback), and the gap between $C_s^{(gf)}$ and $C_s^{(gf^*)}$ is increasing while σ_w^2 is increasing.

IV. CONCLUSIONS

In this paper, we provide inner and outer bounds on the capacity-equivocation regions of the FSM-WC with delayed state feedback, and with or without delayed receiver's channel output feedback. We find that these bounds meet if the channel output for the eavesdropper is a degraded version of that for the legitimate receiver, and the delayed receiver's channel output feedback helps to enhance the rate-equivocation region of the FSM-WC with only delayed state feedback. The results of this paper are further explained via degraded Gaussian and degraded Gaussian fading examples. In these examples, we show that when the channel is changing rapidly, the secrecy capacities go to the infinite asymptote even if the delayed time d is very small, and when the channel is changing slowly, a larger feedback delay is tolerable since the secrecy capacity loss compared with feedback without delay ($d = 0$) is smaller. Moreover, comparing these two examples, we find that the fading may enhance the security of the degraded Gaussian FSM-WC with only delayed state feedback, and the fading may weaken the security of the degraded Gaussian FSM-WC with delayed state and receiver's channel output feedback.

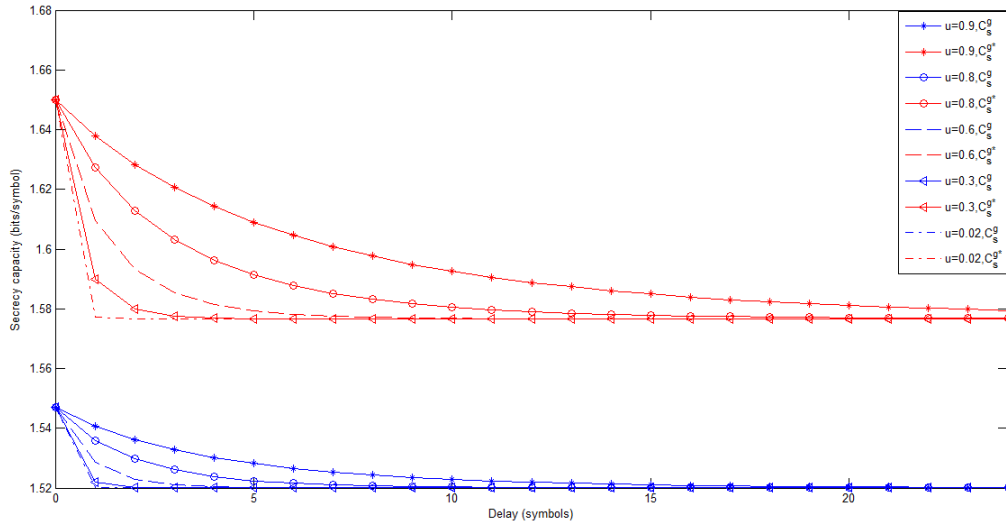

Fig. 9: The comparison of the secrecy capacities $C_s^{(g^*)}$ and $C_s^{(g)}$ for $\mathcal{P}_0 = 100$, $\sigma_G^2 = 1$, $\sigma_B^2 = 100$, $\sigma_w^2 = 100$, $c = 1$, $g(G) = 1$, $g(B) = 0.5$, $l = 0.8$ and several values of u

ACKNOWLEDGEMENT

The authors would like to thank Professor Xuming Fang for his valuable suggestions on improving this paper.

APPENDIX A

PROOF OF THEOREM 1

The main idea of the proof of Theorem 1 is to construct a hybrid encoding-decoding scheme, which combines the rate splitting technique, Wyner's random binning technique [11] with the classical multiplexing coding for the finite state Markov channel [4]. The details of the proof are as follows.

A. Definitions

- The transmitted message W is split into a common message W_c and a private message W_p , i.e., $W = (W_c, W_p)$. Here W_c and W_p are uniformly distributed in the sets $\{1, 2, \dots, 2^{NR_c}\}$ and $\{1, 2, \dots, 2^{NR_p}\}$, respectively. Since W is uniformly distributed in the set $\{1, 2, \dots, 2^{NR}\}$, we have $R = R_c + R_p$. In the remainder of this section, we first prove that the region \mathcal{R}_1

$$\begin{aligned} \mathcal{R}_1 = \{ & (R, R_e) : 0 \leq R = R_c + R_p, \\ & 0 \leq R_c \leq \min\{I(U; Y|S, \tilde{S}), I(U; Z|S, \tilde{S})\}, \\ & 0 \leq R_p \leq I(V; Y|U, S, \tilde{S}), \\ & 0 \leq R_e \leq R_p, \\ & R_e \leq I(V; Y|U, S, \tilde{S}) - I(V; Z|U, S, \tilde{S}) \} \end{aligned}$$

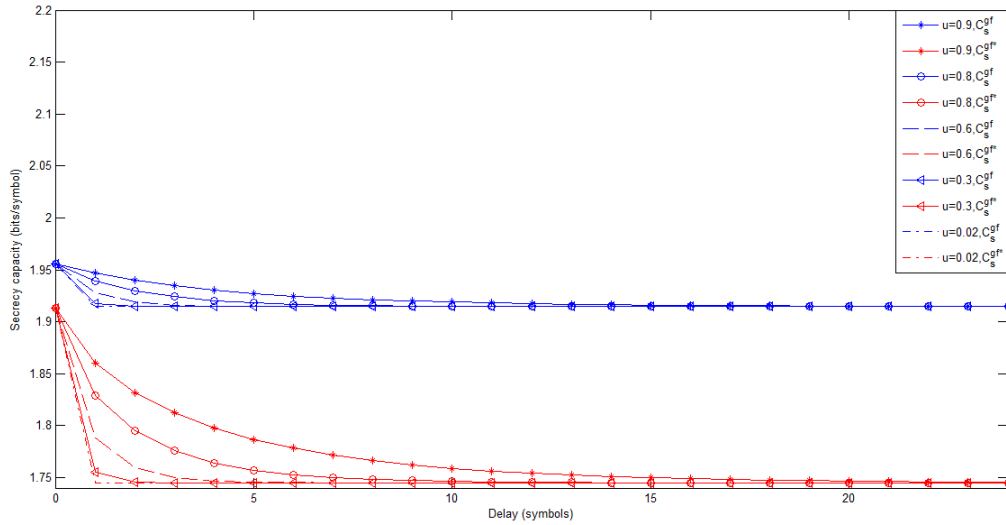

Fig. 10: The comparison of the secrecy capacities $C_s^{(gf^*)}$ and $C_s^{(gf)}$ for $\mathcal{P}_0 = 100$, $\sigma_G^2 = 1$, $\sigma_B^2 = 100$, $\sigma_w^2 = 200$, $c = 1$, $g(G) = 1$, $g(B) = 0.5$, $l = 0.8$ and several values of u

is achievable. Then, using Fourier-Motzkin elimination (see e.g., [41]) to eliminate R_c and R_p from \mathcal{R}_1 , it is easy to see that the region \mathcal{R} is achievable.

- Without loss of generality, we assume that the state takes values in $\mathcal{S} = \{1, 2, \dots, k\}$ and that the steady state probability $\pi(l) > 0$ for all $l \in \mathcal{S}$. Let $N_{\tilde{s}}$ ($1 \leq \tilde{s} \leq k$) be the number satisfying

$$N_{\tilde{s}} = N(\pi(\tilde{s}) - \epsilon'), \quad (\text{A1})$$

where $0 \leq \epsilon' < \min\{\pi(\tilde{s}); \tilde{s} \in \{1, 2, \dots, k\}\}$ and $\epsilon' \rightarrow 0$ as $N \rightarrow \infty$. Denote the transmission rates R_c and R_p for a given \tilde{s} by $R_c(\tilde{s})$ and $R_p(\tilde{s})$ ($1 \leq \tilde{s} \leq k$), respectively, and they satisfy

$$\sum_{\tilde{s}=1}^k \pi(\tilde{s})R_c(\tilde{s}) = R_c, \quad (\text{A2})$$

and

$$\sum_{\tilde{s}=1}^k \pi(\tilde{s})R_p(\tilde{s}) = R_p. \quad (\text{A3})$$

- Divide the common message W_c into k sub-messages $W_{c,1}, \dots, W_{c,k}$, and each sub-message $W_{c,i}$ ($1 \leq i \leq k$) takes values in the set $\mathcal{W}_{c,i} = \{1, 2, \dots, 2^{N_i R_c(i)}\}$. Since the actual transmission rate R_c^* of the common message W_c is denoted by

$$\begin{aligned} R_c^* &= \frac{H(W_c)}{N} = \frac{\sum_{i=1}^k H(W_{c,i})}{N} = \frac{\sum_{i=1}^k N_i R_c(i)}{N} \\ &\stackrel{(a)}{=} \frac{\sum_{i=1}^k N(\pi(i) - \epsilon') R_c(i)}{N} \end{aligned}$$

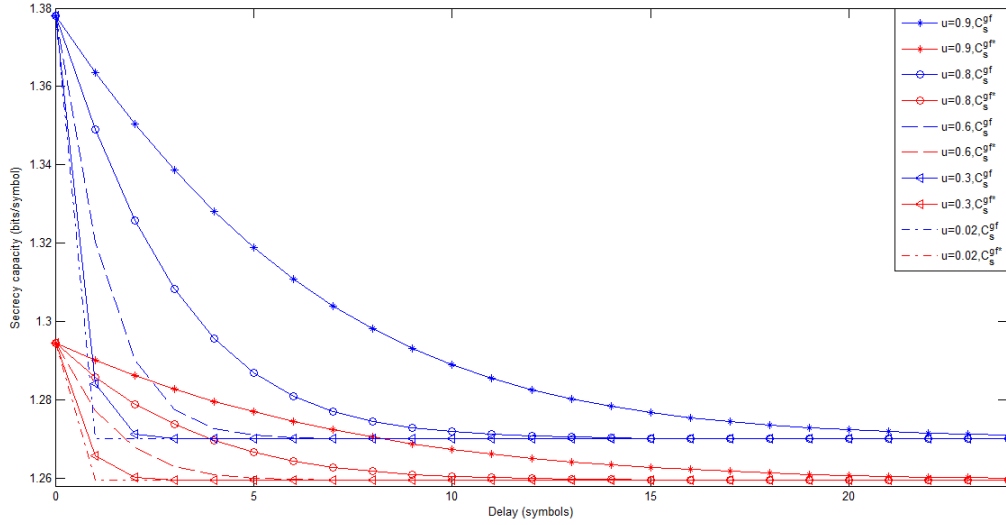

Fig. 11: The comparison of the secrecy capacities $C_s^{(gf*)}$ and $C_s^{(gf)}$ for $\mathcal{P}_0 = 100$, $\sigma_G^2 = 1$, $\sigma_B^2 = 100$, $\sigma_w^2 = 1$, $c = 1$, $g(G) = 1$, $g(B) = 0.5$, $l = 0.8$ and several values of u

$$\begin{aligned}
 &= \sum_{i=1}^k (\pi(i) - \epsilon') R_c(i) \\
 &= \sum_{i=1}^k \pi(i) R_c(i) - \epsilon' \sum_{i=1}^k R_c(i),
 \end{aligned} \tag{A4}$$

where (a) is from (A1). From (A2) and (A4), it is easy to see that R_c^* tends to be R_c while $\epsilon' \rightarrow 0$.

- Divide the private message W_p into k sub-messages $W_{p,1}, \dots, W_{p,k}$, and each sub-message $W_{p,i}$ ($1 \leq i \leq k$) takes values in the set $\mathcal{W}_{p,i} = \{1, 2, \dots, 2^{N_i R_p(i)}\}$. Similar to (A4), the actual transmission rate R_p^* of the private message W_p tends to be R_p while $\epsilon' \rightarrow 0$.

B. Construction of the code-books

Fix the joint probability mass function $P_{UVS\tilde{S}XYZ}(u, v, s, \tilde{s}, x, y, z)$ satisfying (2.11).

- **Construction of U^N :** Construct k code-books $\mathcal{U}^{\tilde{s}}$ of U^N for all $\tilde{s} \in \mathcal{S}$. In each code-book $\mathcal{U}^{\tilde{s}}$, randomly generate $2^{N_{\tilde{s}} R_c(\tilde{s})}$ i.i.d. sequences $u^{N_{\tilde{s}}}$ according to the probability mass function $P_{U|\tilde{s}}(u|\tilde{s})$, and index these sequences as $u^{N_{\tilde{s}}}(i)$, where $1 \leq i \leq 2^{N_{\tilde{s}} R_c(\tilde{s})}$.
- **Construction of V^N :** Construct k code-books $\mathcal{V}^{\tilde{s}}$ of V^N for all $\tilde{s} \in \mathcal{S}$. In each code-book $\mathcal{V}^{\tilde{s}}$, randomly generate $2^{N_{\tilde{s}}(I(V;Y|U,S,\tilde{S}=\tilde{s})+R_c(\tilde{s}))}$ i.i.d. sequences $v^{N_{\tilde{s}}}$ according to the probability mass function $P_{V|U,\tilde{s}}(v|u,\tilde{s})$. Index these sequences of the code-book $\mathcal{V}^{\tilde{s}}$ as $v^{N_{\tilde{s}}}(i_{\tilde{s}}, a_{\tilde{s}}, b_{\tilde{s}})$, where $1 \leq i_{\tilde{s}} \leq 2^{N_{\tilde{s}} R_c(\tilde{s})}$, $a_{\tilde{s}} \in \mathcal{A}_{\tilde{s}} = \{1, 2, \dots, A_{\tilde{s}}\}$, $b_{\tilde{s}} \in \mathcal{B}_{\tilde{s}} = \{1, 2, \dots, B_{\tilde{s}}\}$,

$$A_{\tilde{s}} = 2^{N_{\tilde{s}}(I(V;Y|U,S,\tilde{S}=\tilde{s})-I(V;Z|U,S,\tilde{S}=\tilde{s}))}, \tag{A5}$$

and

$$B_{\tilde{s}} = 2^{N_{\tilde{s}}I(V;Z|U,S,\tilde{S}=\tilde{s})}. \quad (\text{A6})$$

- **Construction of X^N :** For each \tilde{s} , the sequence $x^{N_{\tilde{s}}}$ is i.i.d. generated according to a new discrete memoryless channel (DMC) with transition probability $P_{X|U,V,\tilde{S}}(x|u,v,\tilde{s})$. The inputs of this new DMC are $u^{N_{\tilde{s}}}$ and $v^{N_{\tilde{s}}}$, while the output is $x^{N_{\tilde{s}}}$.

C. Encoding scheme

For a fixed length N , let $L_{\tilde{s}}$ be the number of times during the N symbols for which the delayed feedback state at the transmitter is $\tilde{S} = \tilde{s}$. Every time that the corresponding delayed state is $\tilde{S} = \tilde{s}$, the transmitter chooses the next symbols of u^N and v^N from the component code-books $\mathcal{U}^{\tilde{s}}$ and $\mathcal{V}^{\tilde{s}}$, respectively. Since $L_{\tilde{s}}$ is not necessarily equivalent to $N_{\tilde{s}}$, an error is declared if $L_{\tilde{s}} < N_{\tilde{s}}$, and the codes are filled with zero if $L_{\tilde{s}} > N_{\tilde{s}}$. Therefore, we can send a total of $2^{\sum_{i=1}^k N_i(R_c(i)+R_p(i))}$ messages. Since the state process is stationary and ergodic $\lim_{N \rightarrow \infty} \frac{L_{\tilde{s}}}{N} = Pr\{\tilde{S} = \tilde{s}\}$ in probability. Thus, we have

$$Pr\{L_{\tilde{s}} < N_{\tilde{s}}\} \rightarrow 0, \text{ as } N \rightarrow \infty. \quad (\text{A7})$$

For each $\tilde{s} \in \mathcal{S}$, define $\mathcal{W}_{p,\tilde{s}} = \mathcal{A}_{\tilde{s}} \times \mathcal{J}_{\tilde{s}}$, where $\mathcal{J}_{\tilde{s}} = \{1, 2, \dots, J_{\tilde{s}}\}$ and $J_{\tilde{s}} = 2^{N_{\tilde{s}}(R_p(\tilde{s})-I(V;Y|U,S,\tilde{S}=\tilde{s})+I(V;Z|U,S,\tilde{S}=\tilde{s}))}$. Furthermore, we define the mapping $g_{\tilde{s}} : \mathcal{B}_{\tilde{s}} \rightarrow \mathcal{J}_{\tilde{s}}$, and partition $\mathcal{B}_{\tilde{s}}$ into $J_{\tilde{s}}$ subsets with nearly equal size. Here the ‘‘nearly equal size’’ means

$$\|g_{\tilde{s}}^{-1}(j_1)\| \leq 2\|g_{\tilde{s}}^{-1}(j_2)\|, \forall j_1, j_2 \in \mathcal{J}_{\tilde{s}}. \quad (\text{A8})$$

The transmitted codewords u^N and v^N are obtained by multiplexing the different component codewords. Specifically, first, suppose that a message $w = (w_c, w_p) = (w_{c,1}, \dots, w_{c,k}, w_{p,1}, \dots, w_{p,k})$ is transmitted, and here we denote $w_{p,\tilde{s}}$ ($1 \leq \tilde{s} \leq k$) by $(a_{\tilde{s}}, j_{\tilde{s}})$, where $a_{\tilde{s}} \in \mathcal{A}_{\tilde{s}}$ and $j_{\tilde{s}} \in \mathcal{J}_{\tilde{s}}$. Second, in each component code-book $\mathcal{U}^{\tilde{s}}$ ($1 \leq \tilde{s} \leq k$), the transmitter chooses $u^{N_{\tilde{s}}}(w_{c,\tilde{s}})$ as the \tilde{s} -th component codeword of the transmitted u^N . Third, in each component code-book $\mathcal{V}^{\tilde{s}}$ ($1 \leq \tilde{s} \leq k$), the transmitter chooses $v^{N_{\tilde{s}}}(i_{\tilde{s}}^*, a_{\tilde{s}}^*, b_{\tilde{s}}^*)$ as the \tilde{s} -th component codeword of the transmitted v^N , where $i_{\tilde{s}}^* = w_{c,\tilde{s}}$, $a_{\tilde{s}}^* = a_{\tilde{s}}$, and $b_{\tilde{s}}^*$ is randomly chosen from the sub-set $j_{\tilde{s}}$ of $\mathcal{B}_{\tilde{s}}$.

D. Decoding scheme

- **(Decoding scheme for the receiver:)**

- **(Decoding the common message w_c :)** The delayed feedback state \tilde{S} at the transmitter, which is used to multiplex the component codewords, is also available at the receiver. Thus once the receiver receives y^N and the state sequence s^N , he first demultiplexes them into outputs corresponding to the component code-books and separately decodes each component codeword. To be specific, in each code-book $\mathcal{U}^{\tilde{s}}$, the receiver has $(y^{N_{\tilde{s}}}, s^{N_{\tilde{s}}})$ and tries to search a unique $u^{N_{\tilde{s}}}$ such that $(u^{N_{\tilde{s}}}, y^{N_{\tilde{s}}}, s^{N_{\tilde{s}}})$ are strongly jointly typical sequences [40], i.e.,

$$(u^{N_{\tilde{s}}}, y^{N_{\tilde{s}}}, s^{N_{\tilde{s}}}) \in T_{U,S,Y|\tilde{S}}^{N_{\tilde{s}}}(\epsilon). \quad (\text{A9})$$

If there exists such a unique $u^{N_{\tilde{s}}}$, put out the corresponding index $\hat{w}_{c,\tilde{s}}$. Otherwise, i.e., if no such sequence exists or multiple sequences have different message indices, declare a decoding error. If for all $1 \leq \tilde{s} \leq k$, there exist unique sequences $u^{N_{\tilde{s}}}$ such that (A9) is satisfied, the receiver declares that $\hat{w}_c = (\hat{w}_{c,1}, \hat{w}_{c,2}, \dots, \hat{w}_{c,k})$ is sent. Based on the AEP, the error probability $Pr\{\hat{w}_{c,\tilde{s}} \neq w_{c,\tilde{s}}\}$ ($1 \leq \tilde{s} \leq k$) goes to 0 if

$$R_c(\tilde{s}) \leq I(U; Y|S, \tilde{S} = \tilde{s}). \quad (\text{A10})$$

- **(Decoding the private message w_p):** After decoding $u^{N_{\tilde{s}}}(\hat{w}_{c,\tilde{s}})$ and $\hat{w}_{c,\tilde{s}}$ for all $1 \leq \tilde{s} \leq k$, in each component code-book $\mathcal{V}^{\tilde{s}}$, the receiver tries to find a unique sequence $v^{N_{\tilde{s}}}$ such that

$$(v^{N_{\tilde{s}}}, u^{N_{\tilde{s}}}, y^{N_{\tilde{s}}}, s^{N_{\tilde{s}}}) \in T_{U,V,S,Y|\tilde{S}}^{N_{\tilde{s}}}(\epsilon). \quad (\text{A11})$$

If there exists such a unique $v^{N_{\tilde{s}}}$, put out the corresponding indexes $\hat{i}_{\tilde{s}}$, $\hat{a}_{\tilde{s}}$ and $\hat{b}_{\tilde{s}}$. Otherwise, i.e., if no such sequence exists or multiple sequences have different message indices, declare a decoding error. After the receiver obtains the index $\hat{b}_{\tilde{s}}$, he also knows $\hat{j}_{\tilde{s}}$ since it is the index of the sub-set which $\hat{b}_{\tilde{s}}$ belongs to. Thus, for $1 \leq \tilde{s} \leq k$, the receiver has an estimation $\hat{w}_{p,\tilde{s}}$ of the private message $w_{p,\tilde{s}}$ by letting $\hat{w}_{p,\tilde{s}} = (\hat{a}_{\tilde{s}}, \hat{j}_{\tilde{s}})$. If for all $1 \leq \tilde{s} \leq k$, there exist unique sequences $v^{N_{\tilde{s}}}$ such that (A11) is satisfied, the receiver declares that $\hat{w}_p = (\hat{w}_{p,1}, \hat{w}_{p,2}, \dots, \hat{w}_{p,k})$ is sent. Based on the AEP, the error probability $Pr\{\hat{w}_{p,\tilde{s}} \neq w_{p,\tilde{s}}\}$ ($1 \leq \tilde{s} \leq k$) goes to 0 if

$$R_p(\tilde{s}) \leq I(V; Y|U, S, \tilde{S} = \tilde{s}). \quad (\text{A12})$$

- **(Decoding scheme for the eavesdropper):**

- **(Decoding the common message w_c):** The delayed feedback state \tilde{S} at the transmitter, is also available at the eavesdropper. Thus once the eavesdropper receives z^N and the state sequence s^N , he first demultiplexes them into outputs corresponding to the component code-books and separately decodes each component codeword. To be specific, in each code-book $\mathcal{U}^{\tilde{s}}$, the eavesdropper has $(z^{N_{\tilde{s}}}, s^{N_{\tilde{s}}})$ and tries to search a unique $u^{N_{\tilde{s}}}$ such that $(u^{N_{\tilde{s}}}, z^{N_{\tilde{s}}}, s^{N_{\tilde{s}}})$ are strongly jointly typical sequences [40], i.e.,

$$(u^{N_{\tilde{s}}}, z^{N_{\tilde{s}}}, s^{N_{\tilde{s}}}) \in T_{U,S,Z|\tilde{S}}^{N_{\tilde{s}}}(\epsilon). \quad (\text{A13})$$

If there exists such a unique $u^{N_{\tilde{s}}}$, put out the corresponding index $\check{w}_{c,\tilde{s}}$. Otherwise, i.e., if no such sequence exists or multiple sequences have different message indices, declare a decoding error. If for all $1 \leq \tilde{s} \leq k$, there exist unique sequences $u^{N_{\tilde{s}}}$ such that (A13) is satisfied, the eavesdropper declares that $\check{w}_c = (\check{w}_{c,1}, \check{w}_{c,2}, \dots, \check{w}_{c,k})$ is sent. Based on the AEP, the error probability $Pr\{\check{w}_{c,\tilde{s}} \neq w_{c,\tilde{s}}\}$ ($1 \leq \tilde{s} \leq k$) goes to 0 if

$$R_c(\tilde{s}) \leq I(U; Z|S, \tilde{S} = \tilde{s}). \quad (\text{A14})$$

- (**Given w_c and w_p , decoding $v^{N_{\tilde{s}}}$**): In each component code-book $\mathcal{V}^{\tilde{s}}$ ($1 \leq \tilde{s} \leq k$), given $\tilde{S} = \tilde{s}$, $s^{N_{\tilde{s}}}$, $u^{N_{\tilde{s}}}(w_{c,\tilde{s}})$ and $w_{p,\tilde{s}} = (a_{\tilde{s}}, j_{\tilde{s}})$, the eavesdropper tries to find a unique $\check{b}_{\tilde{s}}$ such that

$$(v^{N_{\tilde{s}}}(w_{c,\tilde{s}}, a_{\tilde{s}}, \check{b}_{\tilde{s}}), u^{N_{\tilde{s}}}(w_{c,\tilde{s}}), z^{N_{\tilde{s}}}, s^{N_{\tilde{s}}}) \in T_{U,V,S,Z|\tilde{S}}^{N_{\tilde{s}}}(\epsilon). \quad (\text{A15})$$

Since the index $b_{\tilde{s}}^*$ of the transmitted $v^{N_{\tilde{s}}}$ is randomly chosen from the sub-set $j_{\tilde{s}}$ of $\mathcal{B}_{\tilde{s}}$ and there are $2^{N_{\tilde{s}}(I(V;Y|U,S,\tilde{S}=\tilde{s})-R_p(\tilde{s}))}$ sequences of $v^{N_{\tilde{s}}}$ in the sub-set $j_{\tilde{s}}$, based on the AEP, the error probability $Pr\{\check{b}_{\tilde{s}} \neq b_{\tilde{s}}^*\}$ ($1 \leq \tilde{s} \leq k$) goes to 0 if

$$I(V;Y|U,S,\tilde{S}=\tilde{s}) - R_p(\tilde{s}) \leq I(V;Z|U,S,\tilde{S}=\tilde{s}). \quad (\text{A16})$$

Combining (A2) with (A10) and (A14), we have

$$\begin{aligned} R_c &= \sum_{\tilde{s}=1}^k \pi(\tilde{s}) R_c(\tilde{s}) \\ &\leq \sum_{\tilde{s}=1}^k \pi(\tilde{s}) \min\{I(U;Y|S,\tilde{S}=\tilde{s}), I(U;Z|S,\tilde{S}=\tilde{s})\} \\ &= \min\{I(U;Y|S,\tilde{S}), I(U;Z|S,\tilde{S})\}, \end{aligned} \quad (\text{A17})$$

and combining (A3) with (A12), we have

$$\begin{aligned} R_p &= \sum_{\tilde{s}=1}^k \pi(\tilde{s}) R_p(\tilde{s}) \\ &\leq \sum_{\tilde{s}=1}^k \pi(\tilde{s}) I(V;Y|U,S,\tilde{S}=\tilde{s}) \\ &= I(V;Y|U,S,\tilde{S}). \end{aligned} \quad (\text{A18})$$

It remains to show that $R_e \leq I(V;Y|U,S,\tilde{S}) - I(V;Z|U,S,\tilde{S})$ and $R_e \leq R_p$, see the followings.

E. Equivocation analysis:

Since the eavesdropper also knows the state S^N and the delayed time d , the equivocation Δ is bounded by

$$\begin{aligned} \Delta &= \frac{1}{N} H(W|Z^N, S^N) = \frac{1}{N} H(W_c, W_p|Z^N, S^N) \\ &\geq \frac{1}{N} H(W_p|Z^N, S^N, W_c) \geq \frac{1}{N} H(W_p|Z^N, S^N, W_c, U^N) \\ &\stackrel{(a)}{=} \frac{1}{N} H(W_p|Z^N, S^N, U^N) = \frac{1}{N} H(W_{p,1}, W_{p,2}, \dots, W_{p,k}|Z^N, S^N, U^N) \\ &= \frac{1}{N} \sum_{\tilde{s}=1}^k H(W_{p,\tilde{s}}|Z^N, S^N, U^N, W_{p,1}, \dots, W_{p,\tilde{s}-1}) \\ &\geq \frac{1}{N} \sum_{\tilde{s}=1}^k H(W_{p,\tilde{s}}|Z^N, S^N, U^N, W_{p,1}, \dots, W_{p,\tilde{s}-1}, \tilde{S}=\tilde{s}) \\ &\stackrel{(b)}{=} \frac{1}{N} \sum_{\tilde{s}=1}^k H(W_{p,\tilde{s}}|Z^{N_{\tilde{s}}}, S^{N_{\tilde{s}}}, U^{N_{\tilde{s}}}, \tilde{S}=\tilde{s}) \end{aligned}$$

$$\begin{aligned}
&= \frac{1}{N} \sum_{\tilde{s}=1}^k (H(W_{p,\tilde{s}}, Z^{N_{\tilde{s}}}, S^{N_{\tilde{s}}}, U^{N_{\tilde{s}}}, \tilde{S} = \tilde{s}) - H(Z^{N_{\tilde{s}}}, S^{N_{\tilde{s}}}, U^{N_{\tilde{s}}}, \tilde{S} = \tilde{s})) \\
&= \frac{1}{N} \sum_{\tilde{s}=1}^k (H(W_{p,\tilde{s}}, Z^{N_{\tilde{s}}}, S^{N_{\tilde{s}}}, U^{N_{\tilde{s}}}, V^{N_{\tilde{s}}}, \tilde{S} = \tilde{s}) - H(V^{N_{\tilde{s}}}|W_{p,\tilde{s}}, Z^{N_{\tilde{s}}}, S^{N_{\tilde{s}}}, U^{N_{\tilde{s}}}, \tilde{S} = \tilde{s})) \\
&\quad - H(Z^{N_{\tilde{s}}}, S^{N_{\tilde{s}}}, U^{N_{\tilde{s}}}, \tilde{S} = \tilde{s})) \\
&\stackrel{(c)}{=} \frac{1}{N} \sum_{\tilde{s}=1}^k (H(Z^{N_{\tilde{s}}}|S^{N_{\tilde{s}}}, U^{N_{\tilde{s}}}, V^{N_{\tilde{s}}}, \tilde{S} = \tilde{s}) + H(S^{N_{\tilde{s}}}, U^{N_{\tilde{s}}}, V^{N_{\tilde{s}}}, \tilde{S} = \tilde{s})) \\
&\quad - H(Z^{N_{\tilde{s}}}|S^{N_{\tilde{s}}}, U^{N_{\tilde{s}}}, \tilde{S} = \tilde{s}) - H(S^{N_{\tilde{s}}}, U^{N_{\tilde{s}}}, \tilde{S} = \tilde{s}) - H(V^{N_{\tilde{s}}}|W_{p,\tilde{s}}, Z^{N_{\tilde{s}}}, S^{N_{\tilde{s}}}, U^{N_{\tilde{s}}}, \tilde{S} = \tilde{s})) \\
&\stackrel{(d)}{\geq} \frac{1}{N} \sum_{\tilde{s}=1}^k (N_{\tilde{s}}H(Z|S, U, V, \tilde{S} = \tilde{s}) - H(Z^{N_{\tilde{s}}}|S^{N_{\tilde{s}}}, U^{N_{\tilde{s}}}, \tilde{S} = \tilde{s})) + H(S^{N_{\tilde{s}}}, U^{N_{\tilde{s}}}, V^{N_{\tilde{s}}}, \tilde{S} = \tilde{s}) - H(S^{N_{\tilde{s}}}, U^{N_{\tilde{s}}}, \tilde{S} = \tilde{s})) \\
&\quad - H(V^{N_{\tilde{s}}}|W_{p,\tilde{s}}, Z^{N_{\tilde{s}}}, S^{N_{\tilde{s}}}, U^{N_{\tilde{s}}}, \tilde{S} = \tilde{s})) \\
&\geq \frac{1}{N} \sum_{\tilde{s}=1}^k (N_{\tilde{s}}H(Z|S, U, V, \tilde{S} = \tilde{s}) - N_{\tilde{s}}H(Z|S, U, \tilde{S} = \tilde{s})) + H(S^{N_{\tilde{s}}}, U^{N_{\tilde{s}}}, V^{N_{\tilde{s}}}, \tilde{S} = \tilde{s}) - H(S^{N_{\tilde{s}}}, U^{N_{\tilde{s}}}, \tilde{S} = \tilde{s})) \\
&\quad - H(V^{N_{\tilde{s}}}|W_{p,\tilde{s}}, Z^{N_{\tilde{s}}}, S^{N_{\tilde{s}}}, U^{N_{\tilde{s}}}, \tilde{S} = \tilde{s})) \\
&= \frac{1}{N} \sum_{\tilde{s}=1}^k (N_{\tilde{s}}H(Z|S, U, V, \tilde{S} = \tilde{s}) - N_{\tilde{s}}H(Z|S, U, \tilde{S} = \tilde{s})) \\
&\quad + H(V^{N_{\tilde{s}}}|S^{N_{\tilde{s}}}, U^{N_{\tilde{s}}}, \tilde{S} = \tilde{s}) - H(V^{N_{\tilde{s}}}|W_{p,\tilde{s}}, Z^{N_{\tilde{s}}}, S^{N_{\tilde{s}}}, U^{N_{\tilde{s}}}, \tilde{S} = \tilde{s})) \\
&\stackrel{(e)}{\geq} \frac{1}{N} \sum_{\tilde{s}=1}^k (N_{\tilde{s}}H(Z|S, U, V, \tilde{S}) - N_{\tilde{s}}H(Z|S, U, \tilde{S} = \tilde{s})) \\
&\quad + N_{\tilde{s}}I(V; Y|U, S, \tilde{S} = \tilde{s}) - 1 - H(V^{N_{\tilde{s}}}|W_{p,\tilde{s}}, Z^{N_{\tilde{s}}}, S^{N_{\tilde{s}}}, U^{N_{\tilde{s}}}, \tilde{S} = \tilde{s})) \\
&\stackrel{(f)}{\geq} \frac{1}{N} \sum_{\tilde{s}=1}^k (N_{\tilde{s}}H(Z|S, U, V, \tilde{S} = \tilde{s}) - N_{\tilde{s}}H(Z|S, U, \tilde{S} = \tilde{s})) + N_{\tilde{s}}I(V; Y|U, S, \tilde{S}) - 1 - N_{\tilde{s}}\epsilon_1) \\
&= \sum_{\tilde{s}=1}^k \frac{N_{\tilde{s}}}{N} (I(V; Y|U, S, \tilde{S} = \tilde{s}) - I(V; Z|U, S, \tilde{S} = \tilde{s}) - \frac{1}{N_{\tilde{s}}} - \epsilon_1) \\
&\stackrel{(g)}{=} \sum_{\tilde{s}=1}^k (\pi(\tilde{s}) - \epsilon')(I(V; Y|U, S, \tilde{S} = \tilde{s}) - I(V; Z|U, S, \tilde{S} = \tilde{s}) - \frac{1}{N_{\tilde{s}}} - \epsilon_1) \\
&= I(V; Y|U, S, \tilde{S}) - I(V; Z|U, S, \tilde{S}) - \sum_{\tilde{s}=1}^k (\pi(\tilde{s}) - \epsilon')(\frac{1}{N_{\tilde{s}}} + \epsilon_1) \\
&\quad - \epsilon' \sum_{\tilde{s}=1}^k (I(V; Y|U, S, \tilde{S}) - I(V; Z|U, S, \tilde{S})), \tag{A19}
\end{aligned}$$

where (a) is from the fact that $H(W_c|U^N) = 0$, (b) is from the the Markov chain $(Z^{N_1}, \dots, Z^{N_{\tilde{s}-1}}, Z^{N_{\tilde{s}+1}}, \dots, Z^{N_k}, U^{N_1}, \dots, U^{N_{\tilde{s}-1}}, U^{N_{\tilde{s}+1}}, \dots, U^{N_k}, S^{N_1}, \dots, S^{N_{\tilde{s}-1}}, S^{N_{\tilde{s}+1}}, \dots, S^{N_k}) \rightarrow (Z^{N_{\tilde{s}}}, S^{N_{\tilde{s}}}, U^{N_{\tilde{s}}}, \tilde{S} = \tilde{s}) \rightarrow W_{p,\tilde{s}}$, which implies that given the \tilde{s} -th component of the sequences Z^N , U^N and S^N , $W_{p,\tilde{s}}$ is independent of the other parts of Z^N , U^N and S^N , (c) is from the fact that $H(W_{p,\tilde{s}}|V^{N_{\tilde{s}}}) = 0$, (d) is from the fact that the channel is a DMC with transition probability $P_{Y,Z|X,S}(y, z|x, s)$, and for each \tilde{s} , $X^{N_{\tilde{s}}}$ is i.i.d. generated according to a new DMC with transition probability $P_{X|U,V,\tilde{S}}(x|u, v, \tilde{s})$, thus we have $H(Z^{N_{\tilde{s}}}|S^{N_{\tilde{s}}}, U^{N_{\tilde{s}}}, V^{N_{\tilde{s}}}, \tilde{S} = \tilde{s}) = N_{\tilde{s}}H(Z|S, U, V, \tilde{S} = \tilde{s})$,

(e) is from the fact that for given \tilde{s} , $u^{N_{\tilde{s}}}$ and $s^{N_{\tilde{s}}}$, $V^{N_{\tilde{s}}}$ has $A_{\tilde{s}} \cdot B_{\tilde{s}}$ possible values, and the encoding mapping function $g_{\tilde{s}}$ partitions $\mathcal{B}_{\tilde{s}}$ into $j_{\tilde{s}}$ subsets with “nearly equal size” (see (A8)), using a similar lemma in [13], we have

$$\frac{1}{N_{\tilde{s}}} H(V^{N_{\tilde{s}}}|S^{N_{\tilde{s}}}, U^{N_{\tilde{s}}}, \tilde{S} = \tilde{s}) \geq \frac{1}{N_{\tilde{s}}} \log A_{\tilde{s}} + \frac{1}{N_{\tilde{s}}} \log B_{\tilde{s}} - \frac{1}{N_{\tilde{s}}}, \quad (\text{A20})$$

(f) is from the fact that given $\tilde{S} = \tilde{s}$, $s^{N_{\tilde{s}}}$, $u^{N_{\tilde{s}}}(w_{c,\tilde{s}})$ and $w_{p,\tilde{s}} = (a_{\tilde{s}}, j_{\tilde{s}})$, the eavesdropper’s decoding error probability of $v^{N_{\tilde{s}}}$ tends to zero if (A16) is satisfied, and thus, by using Fano’s inequality, we have

$$\frac{1}{N_{\tilde{s}}} H(V^{N_{\tilde{s}}}|W_{p,\tilde{s}}, Z^{N_{\tilde{s}}}, S^{N_{\tilde{s}}}, U^{N_{\tilde{s}}}, \tilde{S} = \tilde{s}) \leq \epsilon_1, \quad (\text{A21})$$

where $\epsilon_1 \rightarrow 0$ as $N_{\tilde{s}} \rightarrow \infty$, and (g) is from (A1).

From (A19), we have

$$\Delta \geq I(V; Y|U, S, \tilde{S}) - I(V; Z|U, S, \tilde{S}) - \epsilon_2, \quad (\text{A22})$$

where ϵ_2 is small for sufficiently large N . By the definition of R_e , we can conclude that $R_e \leq I(V; Y|U, S, \tilde{S}) - I(V; Z|U, S, \tilde{S})$.

In addition, we know that (A21) holds if (A16) is satisfied, and this implies that

$$\begin{aligned} R_p &= \sum_{\tilde{s}=1}^k \pi(\tilde{s}) R_p(\tilde{s}) \\ &\geq \sum_{\tilde{s}=1}^k \pi(\tilde{s}) (I(V; Y|U, S, \tilde{S} = \tilde{s}) - I(V; Z|U, S, \tilde{S} = \tilde{s})) \\ &= I(V; Y|U, S, \tilde{S}) - I(V; Z|U, S, \tilde{S}) \geq R_e. \end{aligned} \quad (\text{A23})$$

Thus, $R_e \leq I(V; Y|U, S, \tilde{S}) - I(V; Z|U, S, \tilde{S})$ and $R_e \leq R_p$ are proved, and the achievability proof of the region \mathcal{R}_1 is completed. Finally, using Fourier-Motzkin elimination (see e.g., [41]) to eliminate R_c and R_p from \mathcal{R}_1 , the proof of Theorem 1 is completed.

APPENDIX B

PROOF OF THEOREM 2

In this section, we will prove Theorem 2: all the achievable (R, R_e) pairs are contained in the set \mathcal{R}^{out} . Since $R_e \leq R$ is obvious, we only need to prove the inequalities $R \leq I(V; Y|S, \tilde{S})$ and $R_e \leq I(V; Y|U, S, \tilde{S}) - I(V; Z|U, S, \tilde{S})$ of Theorem 2 in the remainder of this section.

First, define the following auxiliary random variables,

$$U \triangleq (Y^{J-1}, Z_{J+1}^N, S^N, J), V \triangleq (U, W), S \triangleq S_J, \tilde{S} \triangleq S_{J-d}, Y \triangleq Y_J, Z \triangleq Z_J, \quad (\text{A24})$$

where J is a random variable uniformly distributed over $\{1, 2, \dots, N\}$, and it is independent of Y^N , Z^N , W and S^N .

Proof of $R \leq I(V; Y|S, \tilde{S})$: Note that

$$\begin{aligned}
R - \epsilon &\stackrel{(a)}{\leq} \frac{1}{N} H(W) \\
&\stackrel{(b)}{=} \frac{1}{N} H(W|S^N) \\
&= \frac{1}{N} (I(W; Y^N|S^N) + H(W|Y^N, S^N)) \\
&\stackrel{(c)}{\leq} \frac{1}{N} (I(W; Y^N|S^N) + \delta(P_e)) \\
&= \frac{1}{N} \sum_{i=1}^N (H(Y_i|Y^{i-1}, S^N) - H(Y_i|Y^{i-1}, S^N, W)) + \frac{\delta(P_e)}{N} \\
&\leq \frac{1}{N} \sum_{i=1}^N (H(Y_i|S_i, S_{i-d}) - H(Y_i|Y^{i-1}, Z_{i+1}^N, S^N, W)) + \frac{\delta(P_e)}{N} \\
&\stackrel{(d)}{=} \frac{1}{N} \sum_{i=1}^N (H(Y_i|S_i, S_{i-d}) - H(Y_i|Y^{i-1}, Z_{i+1}^N, S^N, W, S_i, S_{i-d})) + \frac{\delta(P_e)}{N} \\
&\stackrel{(e)}{=} \frac{1}{N} \sum_{i=1}^N (H(Y_i|S_i, S_{i-d}, J=i) - H(Y_i|Y^{i-1}, Z_{i+1}^N, S^N, W, S_i, S_{i-d}, J=i)) + \frac{\delta(P_e)}{N} \\
&\stackrel{(f)}{=} H(Y_J|S_J, S_{J-d}, J) - H(Y_J|S_J, S_{J-d}, W, Y^{J-1}, Z_{J+1}^N, S^N, J) + \frac{\delta(P_e)}{N} \\
&\leq H(Y_J|S_J, S_{J-d}) - H(Y_J|S_J, S_{J-d}, W, Y^{J-1}, Z_{J+1}^N, S^N, J) + \frac{\delta(P_e)}{N} \\
&\stackrel{(g)}{=} H(Y|S, \tilde{S}) - H(Y|S, \tilde{S}, V) + \frac{\delta(P_e)}{N} \\
&\stackrel{(h)}{\leq} I(V; Y|S, \tilde{S}) + \frac{\delta(\epsilon)}{N}, \tag{A25}
\end{aligned}$$

where (a) is from (2.10), (b) is from the fact that W is independent of S^N , (c) is from the Fano's inequality, (d) is from the fact that S_i and S_{i-d} (here $S_{i-d} = \text{const}$ when $i \leq d$) are included in S^N , and thus there exists a Markov chain $(S_i, S_{i-d}) \rightarrow (Y^{i-1}, Z_{i+1}^N, S^N, W) \rightarrow Y_i$, (e) is from the fact that J is a random variable (uniformly distributed over $\{1, 2, \dots, N\}$), and it is independent of Y^N , Z^N , W and S^N , (f) is from J is uniformly distributed over $\{1, 2, \dots, N\}$, (g) is from the definitions in (A24), and (h) is from $\delta(P_e)$ is increasing while P_e is increasing, and $P_e \leq \epsilon$. Then, letting $\epsilon \rightarrow 0$, we have $R \leq I(V; Y|S, \tilde{S})$.

Proof of $R_e \leq I(V; Y|U, S, \tilde{S}) - I(V; Z|U, S, \tilde{S})$: By using (2.9) and (2.10), we have

$$\begin{aligned}
R_e - \epsilon &\stackrel{(1)}{\leq} \frac{1}{N} H(W|Z^N, S^N) \\
&= \frac{1}{N} (H(W|S^N) - I(W; Z^N|S^N)) \\
&= \frac{1}{N} (H(W|S^N) - H(W|S^N, Y^N) + H(W|S^N, Y^N) - I(W; Z^N|S^N)) \\
&\stackrel{(2)}{\leq} \frac{1}{N} (I(W; Y^N|S^N) - I(W; Z^N|S^N) + \delta(P_e)) \\
&= \frac{1}{N} \sum_{i=1}^N (I(W; Y_i|Y^{i-1}, S^N) - I(W; Z_i|Z_{i+1}^N, S^N)) + \frac{\delta(P_e)}{N}, \tag{A26}
\end{aligned}$$

where (1) from (2.10), and (2) is from the Fano's inequality.

The character $I(W; Y_i|Y^{i-1}, S^N)$ in (A26) can be processed as

$$\begin{aligned}
I(W; Y_i|Y^{i-1}, S^N) &= H(Y_i|Y^{i-1}, S^N) - H(Y_i|Y^{i-1}, S^N, W) \\
&= H(Y_i|Y^{i-1}, S^N) - H(Y_i|Y^{i-1}, S^N, W) - H(Y_i|Y^{i-1}, Z_{i+1}^N, S^N) + H(Y_i|Y^{i-1}, Z_{i+1}^N, S^N) \\
&\quad + H(Y_i|Y^{i-1}, Z_{i+1}^N, S^N, W) - H(Y_i|Y^{i-1}, Z_{i+1}^N, S^N, W) \\
&= I(Y_i; Z_{i+1}^N|Y^{i-1}, S^N) - I(Y_i; Z_{i+1}^N|Y^{i-1}, S^N, W) + I(W; Y_i|Y^{i-1}, Z_{i+1}^N, S^N),
\end{aligned} \tag{A27}$$

and the character $I(W; Z_i|Z_{i+1}^N, S^N)$ in (A26) can be processed as

$$\begin{aligned}
I(W; Z_i|Z_{i+1}^N, S^N) &= H(Z_i|Z_{i+1}^N, S^N) - H(Z_i|Z_{i+1}^N, S^N, W) \\
&= H(Z_i|Z_{i+1}^N, S^N) - H(Z_i|Z_{i+1}^N, S^N, W) - H(Z_i|Y^{i-1}, Z_{i+1}^N, S^N) + H(Z_i|Y^{i-1}, Z_{i+1}^N, S^N) \\
&\quad + H(Z_i|Y^{i-1}, Z_{i+1}^N, S^N, W) - H(Z_i|Y^{i-1}, Z_{i+1}^N, S^N, W) \\
&= I(Z_i; Y^{i-1}|Z_{i+1}^N, S^N) - I(Z_i; Y^{i-1}|Z_{i+1}^N, S^N, W) + I(W; Z_i|Y^{i-1}, Z_{i+1}^N, S^N).
\end{aligned} \tag{A28}$$

Substituting (A27) and (A28) into (A26), and using the properties

$$\sum_{i=1}^N I(Y_i; Z_{i+1}^N|Y^{i-1}, S^N) = \sum_{i=1}^N I(Z_i; Y^{i-1}|Z_{i+1}^N, S^N) \tag{A29}$$

and

$$\sum_{i=1}^N I(Y_i; Z_{i+1}^N|Y^{i-1}, S^N, W) = \sum_{i=1}^N I(Z_i; Y^{i-1}|Z_{i+1}^N, S^N, W), \tag{A30}$$

we have

$$\begin{aligned}
R_e - \epsilon &\stackrel{(a)}{\leq} \frac{1}{N} \sum_{i=1}^N (I(W; Y_i|Y^{i-1}, Z_{i+1}^N, S^N) - I(W; Z_i|Y^{i-1}, Z_{i+1}^N, S^N)) + \frac{\delta(P_e)}{N} \\
&\stackrel{(b)}{=} \frac{1}{N} \sum_{i=1}^N (I(W; Y_i|Y^{i-1}, Z_{i+1}^N, S^N, S_{i-d}, S_i) - I(W; Z_i|Y^{i-1}, Z_{i+1}^N, S^N, S_{i-d}, S_i)) + \frac{\delta(P_e)}{N} \\
&\stackrel{(c)}{=} \frac{1}{N} \sum_{i=1}^N (I(W; Y_i|Y^{i-1}, Z_{i+1}^N, S^N, S_{i-d}, S_i, J=i) - I(W; Z_i|Y^{i-1}, Z_{i+1}^N, S^N, S_{i-d}, S_i, J=i)) + \frac{\delta(P_e)}{N} \\
&\stackrel{(d)}{=} I(W; Y_J|Y^{J-1}, Z_{J+1}^N, S^N, S_{J-d}, S_J, J) - I(W; Z_J|Y^{J-1}, Z_{J+1}^N, S^N, S_{J-d}, S_J, J) + \frac{\delta(P_e)}{N} \\
&\stackrel{(e)}{=} I(V; Y|U, \tilde{S}, S) - I(V; Z|U, \tilde{S}, S) + \frac{\delta(P_e)}{N} \\
&\stackrel{(f)}{\leq} I(V; Y|U, \tilde{S}, S) - I(V; Z|U, \tilde{S}, S) + \frac{\delta(\epsilon)}{N},
\end{aligned} \tag{A31}$$

where (a) is from (A29) and (A30) (b) is from the fact that S_i and S_{i-d} (here $S_{i-d} = \text{const}$ when $i \leq d$) are included in S^N , (c) is from the fact that J is a random variable (uniformly distributed over $\{1, 2, \dots, N\}$), and it is independent of Y^N , Z^N , W and S^N , (d) is from J is uniformly distributed over $\{1, 2, \dots, N\}$, (e) is from the definitions in (A24), and (f) is from $\delta(P_e)$ is increasing while P_e is increasing, and $P_e \leq \epsilon$. Letting $\epsilon \rightarrow 0$, we have $R_e \leq I(V; Y|U, \tilde{S}, S) - I(V; Z|U, \tilde{S}, S)$. Now it remains to prove the equalities (A29) and (A30), see the followings.

Proof:

Using the chain rule, the left parts of (A29) and (A30) can be re-written as

$$\sum_{i=1}^N I(Y_i; Z_{i+1}^N | Y^{i-1}, S^N) = \sum_{i=1}^N \sum_{j=i+1}^N I(Y_i; Z_j | Y^{i-1}, S^N, Z_{j+1}^N), \quad (\text{A32})$$

and

$$\sum_{i=1}^N I(Y_i; Z_{i+1}^N | Y^{i-1}, S^N, W) = \sum_{i=1}^N \sum_{j=i+1}^N I(Y_i; Z_j | Y^{i-1}, S^N, Z_{j+1}^N, W). \quad (\text{A33})$$

The right parts of (A29) and (A30) can be re-written as

$$\begin{aligned} \sum_{i=1}^N I(Z_i; Y^{i-1} | Z_{i+1}^N, S^N) &= \sum_{i=1}^N \sum_{j=1}^{i-1} I(Y_j; Z_i | Y^{j-1}, S^N, Z_{i+1}^N) \\ &= \sum_{j=1}^N \sum_{i=1}^{j-1} I(Y_i; Z_j | Y^{i-1}, S^N, Z_{j+1}^N) \\ &= \sum_{j=i+1}^N \sum_{i=1}^N I(Y_i; Z_j | Y^{i-1}, S^N, Z_{j+1}^N), \end{aligned} \quad (\text{A34})$$

and

$$\begin{aligned} \sum_{i=1}^N I(Z_i; Y^{i-1} | Z_{i+1}^N, S^N, W) &= \sum_{i=1}^N \sum_{j=1}^{i-1} I(Y_j; Z_i | Y^{j-1}, S^N, Z_{i+1}^N, W) \\ &= \sum_{j=1}^N \sum_{i=1}^{j-1} I(Y_i; Z_j | Y^{i-1}, S^N, Z_{j+1}^N, W) \\ &= \sum_{j=i+1}^N \sum_{i=1}^N I(Y_i; Z_j | Y^{i-1}, S^N, Z_{j+1}^N, W). \end{aligned} \quad (\text{A35})$$

By checking (A32)-(A35), it is easy to see that (A29) and (A30) hold, and the proof is completed. ■

The proof of Theorem 2 is completed.

APPENDIX C PROOF OF (2.13)

Replacing V^N by X^N , and letting W_e, U^N be constants, the achievability of (2.13) is along the lines of the direct proof of Theorem 1 (see Appendix A), and thus we only need to show the converse proof of (2.13). Since $R_e \leq R$ is obvious, it remains to show that $R \leq I(X; Y | S, \tilde{S})$ and $R_e \leq I(X; Y | S, \tilde{S}) - I(X; Z | S, \tilde{S})$, see the followings.

Note that

$$\begin{aligned}
R - \epsilon &\leq \frac{1}{N} H(W) \leq \frac{1}{N} (I(W; Y^N | S^N) + \delta(P_e)) \\
&\stackrel{(a)}{\leq} \frac{1}{N} (I(X^N; Y^N | S^N) + \delta(P_e)) \\
&= \frac{1}{N} \sum_{i=1}^N (H(Y_i | Y^{i-1}, S^N) - H(Y_i | Y^{i-1}, S^N, X^N)) + \frac{\delta(P_e)}{N} \\
&\leq \frac{1}{N} \sum_{i=1}^N (H(Y_i | S_i, S_{i-d}) - H(Y_i | Y^{i-1}, S^N, X^N)) + \frac{\delta(P_e)}{N} \\
&\stackrel{(b)}{=} \frac{1}{N} \sum_{i=1}^N (H(Y_i | S_i, S_{i-d}) - H(Y_i | S_i, X_i)) + \frac{\delta(P_e)}{N} \\
&\stackrel{(c)}{=} \frac{1}{N} \sum_{i=1}^N (H(Y_i | S_i, S_{i-d}) - H(Y_i | S_i, X_i, S_{i-d})) + \frac{\delta(P_e)}{N} \\
&\stackrel{(d)}{=} H(Y_J | S_J, S_{J-d}, J) - H(Y_J | S_J, S_{J-d}, X_J, J) + \frac{\delta(P_e)}{N} \\
&\stackrel{(e)}{\leq} H(Y_J | S_J, S_{J-d}) - H(Y_J | S_J, S_{J-d}, X_J) + \frac{\delta(P_e)}{N} \\
&\stackrel{(f)}{\leq} I(X; Y | S, \tilde{S}) + \frac{\delta(\epsilon)}{N}, \tag{A36}
\end{aligned}$$

where (a) is from $H(W | X^N) = 0$, (b) is from the Markov chain $(Y^{i-1}, S^{i-1}, S_{i+1}^N, X^{i-1}, X_{i+1}^N) \rightarrow (S_i, X_i) \rightarrow Y_i$, (c) is from the Markov chain $S_{i-d} \rightarrow (S_i, X_i) \rightarrow Y_i$, (d) is from the fact that J is a random variable (uniformly distributed over $\{1, 2, \dots, N\}$), and it is independent of Y^N , Z^N , W and S^N , (e) is from the Markov chains $(J, S_{J-d}) \rightarrow (S_J, X_J) \rightarrow Y_J$ and $S_{J-d} \rightarrow (S_J, X_J) \rightarrow Y_J$, and (f) is from the definitions in (A24), $X \triangleq X_J$ and the fact that $\delta(P_e) \leq \delta(\epsilon)$. Then, letting $\epsilon \rightarrow 0$, we have $R \leq I(X; Y | S, \tilde{S})$.

Similarly, note that

$$\begin{aligned}
R_e - \epsilon &\stackrel{(1)}{\leq} \frac{H(W | Z^N, S^N)}{N} \\
&= \frac{1}{N} (H(W | Z^N, S^N) - H(W | Z^N, S^N, Y^N) + H(W | Z^N, S^N, Y^N)) \\
&\stackrel{(2)}{\leq} \frac{1}{N} (I(W; Y^N | Z^N, S^N) + \delta(P_e)) \\
&\leq \frac{1}{N} (H(Y^N | Z^N, S^N) - H(Y^N | Z^N, S^N, W, X^N) + \delta(P_e)) \\
&\stackrel{(3)}{=} \frac{1}{N} (H(Y^N | Z^N, S^N) - H(Y^N | Z^N, S^N, X^N) + \delta(P_e)) \\
&= \frac{1}{N} (I(X^N; Y^N | Z^N, S^N) + \delta(P_e)) \\
&\stackrel{(4)}{=} \frac{1}{N} (H(X^N | Z^N, S^N) - H(X^N | Y^N, S^N) + H(X^N | S^N) - H(X^N | S^N) + \delta(P_e)) \\
&= \frac{1}{N} (I(X^N; Y^N | S^N) - I(X^N; Z^N | S^N) + \delta(P_e)) \\
&\stackrel{(5)}{\leq} \frac{1}{N} (I(X^N; Y^N | S^N) - I(X^N; Z^N | S^N) + \delta(\epsilon)), \tag{A37}
\end{aligned}$$

where (1) is from (2.10), (2) is from Fano's inequality, (3) is from the fact that $H(W|X^N) = 0$, (4) is from the Markov chain $X^N \rightarrow (Y^N, S^N) \rightarrow Z^N$, and (5) is from the fact that $P_e \leq \epsilon$ and $\delta(P_e)$ is increasing while P_e is increasing.

The character $I(X^N; Y^N|S^N) - I(X^N; Z^N|S^N)$ in (A81) can be further bounded by

$$\begin{aligned}
& \frac{1}{N} I(X^N; Y^N|S^N) - I(X^N; Z^N|S^N) \\
& \stackrel{(a)}{=} \frac{1}{N} \sum_{i=1}^N (H(Y_i|Y^{i-1}, S^N) - H(Y_i|X_i, S_i) - H(Z_i|Z^{i-1}, S^N) + H(Z_i|X_i, S_i)) \\
& \stackrel{(b)}{=} \frac{1}{N} \sum_{i=1}^N (H(Y_i|Y^{i-1}, S^N, Z^{i-1}) - H(Y_i|X_i, S_i) - H(Z_i|Z^{i-1}, S^N) + H(Z_i|X_i, S_i)) \\
& \stackrel{(c)}{\leq} \frac{1}{N} \sum_{i=1}^N (H(Y_i|S_i, S_{i-d}, S^N, Z^{i-1}) - H(Y_i|X_i, S_i, S_{i-d}) - H(Z_i|Z^{i-1}, S_i, S_{i-d}, S^N) + H(Z_i|X_i, S_i, S_{i-d})) \\
& \stackrel{(d)}{\leq} \frac{1}{N} \sum_{i=1}^N (H(Y_i|S_i, S_{i-d}) - H(Y_i|X_i, S_i, S_{i-d}) - H(Z_i|S_i, S_{i-d}) + H(Z_i|X_i, S_i, S_{i-d})) \\
& = \frac{1}{N} \sum_{i=1}^N (I(X_i; Y_i|S_i, S_{i-d}) - I(X_i; Z_i|S_i, S_{i-d})) \\
& \stackrel{(e)}{=} I(X_J; Y_J|S_J, S_{J-d}, J) - I(X_J; Z_J|S_J, S_{J-d}, J) \\
& \stackrel{(f)}{\leq} I(X_J; Y_J|S_J, S_{J-d}) - I(X_J; Z_J|S_J, S_{J-d}) \\
& \stackrel{(g)}{=} I(X; Y|S, \tilde{S}) - I(X; Z|S, \tilde{S}), \tag{A38}
\end{aligned}$$

where (a) is from the Markov chains $(Y^{i-1}, S^{i-1}, S_{i+1}^N, X^{i-1}, X_{i+1}^N) \rightarrow (S_i, X_i) \rightarrow Y_i$ and $(Z^{i-1}, S^{i-1}, S_{i+1}^N, X^{i-1}, X_{i+1}^N) \rightarrow (S_i, X_i) \rightarrow Z_i$, (b) is from the Markov chain $Y_i \rightarrow (Y^{i-1}, S^N) \rightarrow Z^{i-1}$, (c) is from the Markov chains $S_{i-d} \rightarrow (X_i, S_i) \rightarrow Y_i$ and $S_{i-d} \rightarrow (X_i, S_i) \rightarrow Z_i$, and the fact that S_i and S_{i-d} are a part of S^N (here note that $S_{i-d} = \text{const}$ if $i \leq d$), (d) is from

$$H(Y_i|S_i, S_{i-d}, S^N, Z^{i-1}) - H(Z_i|Z^{i-1}, S_i, S_{i-d}, S^N) \leq H(Y_i|S_i, S_{i-d}) - H(Z_i|S_i, S_{i-d}), \tag{A39}$$

(e) is from the fact that J is a random variable (uniformly distributed over $\{1, 2, \dots, N\}$), and it is independent of Y^N, Z^N, W and S^N , (f) is from the Markov chains $(J, S_{J-d}) \rightarrow (S_J, X_J) \rightarrow Y_J, S_{J-d} \rightarrow (S_J, X_J) \rightarrow Y_J, (J, S_{J-d}) \rightarrow (S_J, X_J) \rightarrow Z_J, S_{J-d} \rightarrow (S_J, X_J) \rightarrow Z_J$ and the fact that

$$H(Y_J|S_J, S_{J-d}, J) - H(Z_J|S_J, S_{J-d}, J) \leq H(Y_J|S_J, S_{J-d}) - H(Z_J|S_J, S_{J-d}), \tag{A40}$$

and (g) is from the definitions in (A24) and $X \triangleq X_J$. Here note that the proof of (A40) is analogous to that of (A39), and thus we only need to prove the above (A39), see the followings.

Proof of (A39):

Proof: Note that (A39) is equivalent to

$$I(Z_i; Z^{i-1}, S^N|S_i, S_{i-d}) \leq I(Y_i; S^N, Z^{i-1}|S_i, S_{i-d}). \tag{A41}$$

Since

$$\begin{aligned}
I(Z_i; Z^{i-1}, S^N | S_i, S_{i-d}) &= H(Z^{i-1}, S^N | S_i, S_{i-d}) - H(Z^{i-1}, S^N | S_i, S_{i-d}, Z_i) \\
&\leq H(Z^{i-1}, S^N | S_i, S_{i-d}) - H(Z^{i-1}, S^N | S_i, S_{i-d}, Z_i, Y_i) \\
&\stackrel{(1)}{=} H(Z^{i-1}, S^N | S_i, S_{i-d}) - H(Z^{i-1}, S^N | S_i, S_{i-d}, Y_i) \\
&= I(Y_i; S^N, Z^{i-1} | S_i, S_{i-d}), \tag{A42}
\end{aligned}$$

where (1) is from the Markov chain $(Z^{i-1}, S^N) \rightarrow (S_i, S_{i-d}, Y_i) \rightarrow Z_i$. Then it is easy to see that (A41) is proved, and thus the proof of (A39) is completed. ■

Substituting (A38) into (A81), and letting $\epsilon \rightarrow 0$, $R_e \leq I(X; Y | S, \tilde{S}) - I(X; Z | S, \tilde{S})$ is proved. The converse and entire proof of (2.13) is completed.

APPENDIX D PROOF OF THEOREM 3

Rate splitting, block Markov coding, multiplexing random binning, and the idea of using the delayed receiver's channel output feedback as a secret key [39] are combined to show the achievability of \mathcal{R}^{fi} in Theorem 3. The outline of the proof is as follows. Notations and definitions are given in Subsection D-A, the construction of the code-books are shown in Subsection D-B, the encoding and decoding schemes are respectively introduced in Subsection D-C and Subsection D-D, and the equivocation analysis is shown in Subsection D-E.

A. Definitions

- The state takes values in $\mathcal{S} = \{1, 2, \dots, k\}$ and the steady state probability $\pi(l) > 0$ for all $l \in \mathcal{S}$. Let $N_{\tilde{s}}$ ($1 \leq \tilde{s} \leq k$) be the number satisfying

$$N_{\tilde{s}} = N(\pi(\tilde{s}) - \epsilon'), \tag{A43}$$

where $0 \leq \epsilon' < \min\{\pi(\tilde{s}); \tilde{s} \in \{1, 2, \dots, k\}\}$ and $\epsilon' \rightarrow 0$ as $N \rightarrow \infty$.

- The message $W = (W_1, \dots, W_n)$ is transmitted through n blocks, and similar to the definitions in Appendix A, the uniformly distributed message W is divided into a common message W_c and a private message W_p ($W = (W_c, W_p)$), and W , W_c and W_p take values in the sets $\{1, 2, \dots, 2^{nNR}\}$, $\{1, 2, \dots, 2^{nNR_c}\}$ and $\{1, 2, \dots, 2^{nNR_p}\}$, respectively. Here $R = R_c + R_p$. In the remainder of this section, we first prove

$$\begin{aligned}
\mathcal{R}^{fi\infty} &= \{(R_c, R_p, R_e) : 0 \leq R_e \leq R_p, \\
R_c &\leq \min\{I(U; Y | S, \tilde{S}), I(U; Z | S, \tilde{S})\}, \\
R_p &\leq I(V; Y | U, S, \tilde{S}), \\
R_e &\leq [I(V; Y | U, S, \tilde{S}) - I(V; Z | U, S, \tilde{S})]^+ + H(Y | V, Z, S, \tilde{S})\}, \tag{A44}
\end{aligned}$$

is achievable. Then, using Fourier-Motzkin elimination to eliminate R_c and R_p from $\mathcal{R}^{fi\infty}$, \mathcal{R}^{fi} is directly obtained.

- In order to prove $\mathcal{R}^{f^{i\circ}}$ is achievable, it is sufficient to show the following two cases are achievable.
 - (Case 1:) for the case that $I(V; Y|U, S, \tilde{S}) \geq I(V; Z|U, S, \tilde{S})$, we only need to show that $(R_c = \min\{I(U; Y|S, \tilde{S}), I(U; Z|S, \tilde{S})\}, R_p = I(V; Y|U, S, \tilde{S}), R_e = I(V; Y|U, S, \tilde{S}) - I(V; Z|U, S, \tilde{S}) + R_f)$ is achievable, where

$$R_f = \min\{H(Y|V, Z, S, \tilde{S}), I(V; Z|U, S, \tilde{S})\}. \quad (\text{A45})$$

- (Case 2:) for the case that $I(V; Y|U, S, \tilde{S}) < I(V; Z|U, S, \tilde{S})$, we only need to show that $(R_c = \min\{I(U; Y|S, \tilde{S}), I(U; Z|S, \tilde{S})\}, R_p = I(V; Y|U, S, \tilde{S}), R_e = R_f^*)$ is achievable, where

$$R_f^* = \min\{H(Y|V, Z, S, \tilde{S}), I(V; Y|U, S, \tilde{S})\}. \quad (\text{A46})$$

- Define

$$R_{p,1} = [I(V; Y|U, S, \tilde{S}) - I(V; Z|U, S, \tilde{S})]^+, \quad (\text{A47})$$

and

$$R_p = R_{p,1} + R_{p,2}. \quad (\text{A48})$$

- In block i ($1 \leq i \leq n$), the message W_i is divided into k sub-messages, i.e., $W_i = (W_{i,1}, \dots, W_{i,k})$, where $W_{i,j} = (W_{i,j,c}, W_{i,j,p,1}, W_{i,j,p,2})$ ($1 \leq j \leq k$), $W_{i,j,c}$, $W_{i,j,p,1}$ and $W_{i,j,p,2}$ take values in the sets $\{1, 2, \dots, 2^{N_j R_c(j)}\}$, $\{1, 2, \dots, 2^{N_j R_{p,1}(j)}\}$ and $\{1, 2, \dots, 2^{N_j R_{p,2}(j)}\}$, respectively, and N_j satisfies (A43). Here

$$R_c(j) = \min\{I(U; Y|S, \tilde{S} = j), I(U; Z|S, \tilde{S} = j)\}, \quad (\text{A49})$$

$$R_{p,1}(j) = [I(V; Y|U, S, \tilde{S} = j) - I(V; Z|U, S, \tilde{S} = j)]^+, \quad (\text{A50})$$

$$\begin{aligned} R_{p,2}(j) &= R_p(j) - R_{p,1}(j) \\ &= I(V; Y|U, S, \tilde{S} = j) - [I(V; Y|U, S, \tilde{S} = j) - I(V; Z|U, S, \tilde{S} = j)]^+ \\ &= \min\{I(V; Y|U, S, \tilde{S} = j), I(V; Z|U, S, \tilde{S} = j)\}. \end{aligned} \quad (\text{A51})$$

Note that $R_c(j)$, $R_{p,1}(j)$ and $R_{p,2}(j)$ are the transmission rates R_c , $R_{p,1}$ and $R_{p,2}$ for a given $\tilde{s} = j$, respectively. Furthermore, it is easy to see that

$$\sum_{\tilde{s}=1}^k \pi(\tilde{s}) R_c(\tilde{s}) = R_c, \quad \sum_{\tilde{s}=1}^k \pi(\tilde{s}) R_{p,1}(\tilde{s}) = R_{p,1}, \quad \sum_{\tilde{s}=1}^k \pi(\tilde{s}) R_{p,2}(\tilde{s}) = R_{p,2}. \quad (\text{A52})$$

From the above definitions, it is easy to see that $W_c = (W_{1,1,c}, \dots, W_{1,k,c}, W_{2,1,c}, \dots, W_{2,k,c}, \dots, W_{n,1,c}, \dots, W_{n,k,c})$ and $W_p = (W_{p,1}, W_{p,2})$, where $W_{p,1} = (W_{1,1,p,1}, \dots, W_{1,k,p,1}, W_{2,1,p,1}, \dots, W_{2,k,p,1}, \dots, W_{n,1,p,1}, \dots, W_{n,k,p,1})$ and $W_{p,2} = (W_{1,1,p,2}, \dots, W_{1,k,p,2}, W_{2,1,p,2}, \dots, W_{2,k,p,2}, \dots, W_{n,1,p,2}, \dots, W_{n,k,p,2})$.

- The transmission rate R_c^* of the common message W_c is denoted by

$$\begin{aligned}
R_c^* &= \frac{H(W_c)}{nN} = \frac{\sum_{i=1}^n \sum_{j=1}^k H(W_{i,j,c})}{nN} = \frac{\sum_{i=1}^n \sum_{j=1}^k N_j R_c(j)}{nN} \\
&\stackrel{(a)}{=} \frac{\sum_{i=1}^n \sum_{j=1}^k N(\pi(j) - \epsilon') R_c(j)}{nN} \\
&= \sum_{j=1}^k (\pi(j) - \epsilon') R_c(j) \\
&= \sum_{j=1}^k \pi(j) R_c(j) - \epsilon' \sum_{j=1}^k R_c(j), \tag{A53}
\end{aligned}$$

where (a) is from (A43). From (A49) and (A53), it is easy to see that R_c^* tends to be R_c while $\epsilon' \rightarrow 0$.

Similarly, the transmission rate R_p^* of the private message W_p tends to be R_p while $\epsilon' \rightarrow 0$.

- Let \tilde{U}_i ($1 \leq i \leq n$) be the random vector with length N for block i and $U^n = (\tilde{U}_1, \dots, \tilde{U}_n)$. Similarly, $S^n = (\tilde{S}_1, \dots, \tilde{S}_n)$, $V^n = (\tilde{V}_1, \dots, \tilde{V}_n)$, $X^n = (\tilde{X}_1, \dots, \tilde{X}_n)$, $Y^n = (\tilde{Y}_1, \dots, \tilde{Y}_n)$ and $Z^n = (\tilde{Z}_1, \dots, \tilde{Z}_n)$. The specific values of the above random vectors are denoted by lower case letters.

B. Construction of the code-books

Fix the joint probability mass function $P_{UVS\tilde{S}XYZ}(u, v, s, \tilde{s}, x, y, z)$ satisfying (2.17).

- **Construction of U^N :** Construct k code-books $\mathcal{U}^{\tilde{s}}$ of U^N for all $\tilde{s} \in \mathcal{S}$. In each code-book $\mathcal{U}^{\tilde{s}}$, randomly generate $2^{N_{\tilde{s}} R_c(\tilde{s})}$ i.i.d. sequences $u^{N_{\tilde{s}}}$ according to the probability mass function $P_{U|\tilde{S}}(u|\tilde{s})$, and index these sequences as $u^{N_{\tilde{s}}}(i)$, where $1 \leq i \leq 2^{N_{\tilde{s}} R_c(\tilde{s})}$.
- **Construction of V^N :** Construct k code-books $\mathcal{V}^{\tilde{s}}$ of V^N for all $\tilde{s} \in \mathcal{S}$. In each code-book $\mathcal{V}^{\tilde{s}}$, randomly generate $2^{N_{\tilde{s}}(R_p(\tilde{s})+R_c(\tilde{s}))}$ i.i.d. sequences $v^{N_{\tilde{s}}}$ according to the probability mass function $P_{V|U,\tilde{S}}(v|u, \tilde{s})$. Index these sequences of the code-book $\mathcal{V}^{\tilde{s}}$ as $v^{N_{\tilde{s}}}(i_{\tilde{s}}, a_{\tilde{s}}, b_{\tilde{s}})$, where $1 \leq i_{\tilde{s}} \leq 2^{N_{\tilde{s}} R_c(\tilde{s})}$, $a_{\tilde{s}} \in \mathcal{A}_{\tilde{s}} = \{1, 2, \dots, A_{\tilde{s}}\}$, $b_{\tilde{s}} \in \mathcal{B}_{\tilde{s}} = \{1, 2, \dots, B_{\tilde{s}}\}$,

$$A_{\tilde{s}} = 2^{N_{\tilde{s}}[I(V;Y|U,S,\tilde{S}=\tilde{s})-I(V;Z|U,S,\tilde{S}=\tilde{s})]^+}, \tag{A54}$$

and

$$B_{\tilde{s}} = 2^{N_{\tilde{s}} I(V;Z|U,S,\tilde{S}=\tilde{s})}. \tag{A55}$$

From (A51) and (A55), it is easy to see that $2^{N_{\tilde{s}} R_{p,2}(\tilde{s})} \leq B_{\tilde{s}}$. Thus we partition $\mathcal{B}_{\tilde{s}}$ into $2^{N_{\tilde{s}} R_{p,2}(\tilde{s})}$ bins, and each bin has $2^{N_{\tilde{s}}(I(V;Z|U,S,\tilde{S}=\tilde{s})-R_{p,2}(\tilde{s}))}$ elements.

- **Construction of X^N :** For each \tilde{s} , the sequence $x^{N_{\tilde{s}}}$ is i.i.d. generated according to a new discrete memoryless channel (DMC) with transition probability $P_{X|U,V,\tilde{S}}(x|u, v, \tilde{s})$. The inputs of this new DMC are $u^{N_{\tilde{s}}}$ and $v^{N_{\tilde{s}}}$, while the output is $x^{N_{\tilde{s}}}$.

C. Encoding scheme

The codeword in each block has length N . Let $L_{\tilde{s}}$ be the number of times during the N symbols for which the delayed feedback state at the transmitter is $\tilde{S} = \tilde{s}$. Every time that the corresponding delayed state is $\tilde{S} = \tilde{s}$, the transmitter chooses the next symbols of u^N and v^N from the component code-books $\mathcal{U}^{\tilde{s}}$ and $\mathcal{V}^{\tilde{s}}$, respectively. Since $L_{\tilde{s}}$ is not necessarily equivalent to $N_{\tilde{s}}$, an error is declared if $L_{\tilde{s}} < N_{\tilde{s}}$, and the codes are filled with zero if $L_{\tilde{s}} > N_{\tilde{s}}$. Since the state process is stationary and ergodic $\lim_{N \rightarrow \infty} \frac{L_{\tilde{s}}}{N} = Pr\{\tilde{S} = \tilde{s}\}$ in probability. Thus, we have

$$Pr\{L_{\tilde{s}} < N_{\tilde{s}}\} \rightarrow 0, \text{ as } N \rightarrow \infty. \quad (\text{A56})$$

For the i -th block ($1 \leq i \leq n$), the transmitted message is $w_i = (w_{i,1,c}, w_{i,1,p,1}, w_{i,1,p,2}, \dots, w_{i,k,c}, w_{i,k,p,1}, w_{i,k,p,2})$. The encoding scheme is considered into two steps. First, for block $1 \leq i \leq 2d$, the encoding scheme is as follows.

- (Choosing \tilde{u}_i ;) In each component code-book $\mathcal{U}^{\tilde{s}}$ ($1 \leq \tilde{s} \leq k$), the transmitter chooses $\tilde{u}_i^{N_{\tilde{s}}}(w_{i,\tilde{s},c})$ as the \tilde{s} -th component codeword of the transmitted \tilde{u}_i . The transmitted codeword \tilde{u}_i is obtained by multiplexing the different component codewords.
- (Choosing \tilde{v}_i ;) In each component code-book $\mathcal{V}^{\tilde{s}}$ ($1 \leq \tilde{s} \leq k$), the transmitter chooses $\tilde{v}_i^{N_{\tilde{s}}}(i_{\tilde{s}}^*, a_{\tilde{s}}^*, b_{\tilde{s}}^*)$ as the \tilde{s} -th component codeword of the transmitted \tilde{v}_i , where $i_{\tilde{s}}^* = w_{i,\tilde{s},c}$, $a_{\tilde{s}}^* = w_{i,\tilde{s},p,1}$, and $b_{\tilde{s}}^*$ is randomly chosen from the bin $w_{i,\tilde{s},p,2}$ of $\mathcal{B}_{\tilde{s}}$. The transmitted codeword \tilde{v}_i is obtained by multiplexing the different component codewords.

Second, for block $2d+1 \leq i \leq n$, the encoding scheme is as follows.

- The choosing of \tilde{u}_i for block $2d+1 \leq i \leq n$ is the same as that in block $1 \leq i \leq 2d$.
- (Generation of the key;) In block $2d+1 \leq i \leq n$, the transmitter has already known \tilde{s}_{i-2d} , and it is used to multiplex the component codewords \tilde{u}_{i-d} , \tilde{v}_{i-d} and vectors \tilde{s}_{i-d} , \tilde{x}_{i-d} , \tilde{y}_{i-d} and \tilde{z}_{i-d} . Once the transmitter receives the delayed feedback \tilde{y}_{i-d} and \tilde{s}_{i-d} , he first demultiplexes them into $\tilde{y}_{i-d}^{N_1}, \tilde{y}_{i-d}^{N_2}, \dots, \tilde{y}_{i-d}^{N_k}$ and $\tilde{s}_{i-d}^{N_1}, \tilde{s}_{i-d}^{N_2}, \dots, \tilde{s}_{i-d}^{N_k}$. Then, when the transmitter receives $\tilde{y}_{i-d}^{N_j}$ ($1 \leq j \leq k$), he gives up if $\tilde{y}_{i-d}^{N_j} \notin T_{Y|V,S,\tilde{s}}^{N_j}(\tilde{v}_{i-d}^{N_j}, \tilde{s}_{i-d}^{N_j}, \tilde{s} = j)$. It is easy to see that for $\tilde{s} = j$, the probability for giving up at the $i-d$ -th block tends to 0 as $N \rightarrow \infty$ (here $N_j = N(\pi(j) - \epsilon')$). In the case $\tilde{y}_{i-d}^{N_j} \in T_{Y|V,S,\tilde{s}}^{N_j}(\tilde{v}_{i-d}^{N_j}, \tilde{s}_{i-d}^{N_j}, \tilde{s} = j)$, generate a mapping

$$g_{i,j} : \tilde{y}_{i-d}^{N_j} \rightarrow \{1, 2, \dots, 2^{N_j R_f(j)}\} \quad (\text{A57})$$

for case 1, and

$$g_{i,j} : \tilde{y}_{i-d}^{N_j} \rightarrow \{1, 2, \dots, 2^{N_j R_f^*(j)}\} \quad (\text{A58})$$

for case 2. Here note that

$$R_f(j) = \min\{H(Y|V, Z, S, \tilde{S} = j), I(V; Z|U, S, \tilde{S} = j)\}, \quad (\text{A59})$$

$$R_f^*(j) = \min\{H(Y|V, Z, S, \tilde{S} = j), I(V; Y|U, S, \tilde{S} = j)\}. \quad (\text{A60})$$

Define a random variable $K_{i,j}^* = g_{i,j}(\tilde{Y}_{i-d}^{N_j})$ ($2d+1 \leq i \leq n$), which is uniformly distributed over $\{1, 2, \dots, 2^{N_j R_f(j)}\}$ or $\{1, 2, \dots, 2^{N_j R_f^*(j)}\}$, and $K_{i,j}^*$ is independent of $\tilde{U}_i, \tilde{V}_i, \tilde{S}_i, \tilde{X}_i, \tilde{Y}_i, \tilde{Z}_i$ and W_i . Here note that $K_{i,j}^*$ is used as a secret key shared by the transmitter and the receiver, and $k_{i,j}^*$ is a specific value of $K_{i,j}^*$. Reveal the mapping $g_{i,j}$ to the transmitter, receiver and the eavesdropper.

- (Choosing \tilde{v}_i .) From (A51), (A59) and (A60), it is easy to see that $R_{p,2}(j) \geq R_f(j)$ for case 1, and $R_{p,2}(j) \geq R_f^*(j)$ for case 2. Thus, for block $2d+1 \leq i \leq n$ and $\tilde{s} = j$ ($1 \leq j \leq k$), divide the component message $w_{i,j,p,2}$ into $w_{i,j,p,2}^*$ and $w_{i,j,p,2}^{**}$, i.e., $w_{i,j,p,2} = (w_{i,j,p,2}^*, w_{i,j,p,2}^{**})$, where $w_{i,j,p,2}^* \in \{1, 2, \dots, 2^{N_j R_f(j)}\}$, $w_{i,j,p,2}^{**} \in \{1, 2, \dots, 2^{N_j(R_{p,2}(j)-R_f(j))}\}$ for case 1, and $w_{i,j,p,2}^* \in \{1, 2, \dots, 2^{N_j R_f^*(j)}\}$, $w_{i,j,p,2}^{**} \in \{1, 2, \dots, 2^{N_j(R_{p,2}(j)-R_f^*(j))}\}$ for case 2. For both cases, in each component code-book $\mathcal{V}^{\tilde{s}}$ ($1 \leq \tilde{s} \leq k$), the transmitter chooses $\tilde{v}_i^{N_{\tilde{s}}}(i_{\tilde{s}}^*, a_{\tilde{s}}^*, b_{\tilde{s}}^*)$ as the \tilde{s} -th component codeword of the transmitted \tilde{v}_i , where $i_{\tilde{s}}^* = w_{i,\tilde{s},c}$, $a_{\tilde{s}}^* = w_{i,\tilde{s},p,1}$, and $b_{\tilde{s}}^*$ is randomly chosen from the bin $(w_{i,j,p,2}^* \oplus k_{i,j}^*, w_{i,j,p,2}^{**})$ of $\mathcal{B}_{\tilde{s}}$, where \oplus is the modulo addition over $\{1, 2, \dots, 2^{N_j R_f(j)}\}$ for case 1 and $\{1, 2, \dots, 2^{N_j R_f^*(j)}\}$ for case 2. Here note that since $K_{i,j}^*$ and $W_{i,j,p,2}^*$ are independent and uniformly distributed over the same alphabet, $K_{i,j}^* \oplus W_{i,j,p,2}^*$ is also independent of $K_{i,j}^*$ and $W_{i,j,p,2}^*$, and it is also uniformly distributed over the same alphabet as that of $K_{i,j}^*$ and $W_{i,j,p,2}^*$. The transmitted codeword \tilde{v}_i is obtained by multiplexing the different component codewords.

D. Decoding scheme

- (Decoding scheme for the receiver:)

- (Decoding the common message $w_{i,c}$ for block $1 \leq i \leq n$.) The delayed feedback state \tilde{S} at the transmitter, which is used to multiplex the component codewords, is also available at the receiver. For block $1 \leq i \leq n$, once the receiver receives \tilde{y}_i and the state sequence \tilde{s}_i , he first demultiplexes them into outputs corresponding to the component code-books and separately decodes each component codeword. To be specific, in each code-book $\mathcal{U}^{\tilde{s}}$, the receiver has $(\tilde{y}_i^{N_{\tilde{s}}}, \tilde{s}_i^{N_{\tilde{s}}})$ and tries to search a unique $\tilde{u}_i^{N_{\tilde{s}}}$ such that

$$(\tilde{u}_i^{N_{\tilde{s}}}, \tilde{y}_i^{N_{\tilde{s}}}, \tilde{s}_i^{N_{\tilde{s}}}) \in T_{UY S|\tilde{S}}^{N_{\tilde{s}}}(\epsilon). \quad (\text{A61})$$

If there exists such a unique $\tilde{u}_i^{N_{\tilde{s}}}$, put out the corresponding index $\hat{w}_{i,\tilde{s},c}$. Otherwise, i.e., if no such sequence exists or multiple sequences have different message indices, declare a decoding error. If for all $1 \leq \tilde{s} \leq k$, there exist unique sequences $\tilde{u}_i^{N_{\tilde{s}}}$ satisfying (A61), the receiver declares that $\hat{w}_{i,c} = (\hat{w}_{i,1,c}, \hat{w}_{i,2,c}, \dots, \hat{w}_{i,k,c})$ is sent in block i . Based on the AEP and (A49), it is easy to see that the error probability $Pr\{\hat{w}_{i,\tilde{s},c} \neq w_{i,\tilde{s},c}\}$ ($1 \leq \tilde{s} \leq k$) goes to 0.

- (Decoding the private message $w_{i,p}$ for block $1 \leq i \leq 2d$.) After decoding $\tilde{u}_i^{N_{\tilde{s}}}$ for all $1 \leq \tilde{s} \leq k$, in each component code-book $\mathcal{V}^{\tilde{s}}$, the receiver tries to find a unique sequence $\tilde{v}_i^{N_{\tilde{s}}}$ such that

$$(\tilde{v}_i^{N_{\tilde{s}}}, \tilde{u}_i^{N_{\tilde{s}}}, \tilde{y}_i^{N_{\tilde{s}}}, \tilde{s}_i^{N_{\tilde{s}}}) \in T_{V U Y S|\tilde{S}}^{N_{\tilde{s}}}(\epsilon). \quad (\text{A62})$$

If there exists such a unique $\tilde{v}_i^{N_{\tilde{s}}}$, put out the corresponding indexes $\hat{i}_{\tilde{s}}^*$, $\hat{a}_{\tilde{s}}^*$ and $\hat{b}_{\tilde{s}}^*$. Otherwise, i.e., if no such sequence exists or multiple sequences have different message indices, declare a decoding error. For

block $1 \leq i \leq 2d$, after the receiver obtains the index \hat{b}_s^* , he also knows $\hat{w}_{i,\tilde{s},p,2}$ since it is the index of the bin which \hat{b}_s^* belongs to. Thus, for $1 \leq \tilde{s} \leq k$, the receiver has an estimation $\hat{w}_{i,\tilde{s},p}$ of the private message $w_{i,\tilde{s},p}$ by letting $\hat{w}_{i,\tilde{s},p} = (\hat{a}_s^*, \hat{w}_{i,\tilde{s},p,2})$. If for all $1 \leq \tilde{s} \leq k$, there exist unique sequences $\tilde{v}_i^{N_{\tilde{s}}}$ such that (A62) is satisfied, the receiver declares that $\hat{w}_{i,p} = (\hat{w}_{i,1,p}, \hat{w}_{i,2,p}, \dots, \hat{w}_{i,k,p})$ is sent for block i . Based on the AEP and $R_p(\tilde{s}) = I(V; Y|U, S, \tilde{S} = \tilde{s})$, it is easy to see that the error probability $Pr\{\hat{w}_{i,\tilde{s},p} \neq w_{i,\tilde{s},p}\}$ ($1 \leq \tilde{s} \leq k$) goes to 0.

- **(Decoding the private message $w_{i,p}$ for block $2d + 1 \leq i \leq n$):** For block $2d + 1 \leq i \leq n$ and $1 \leq \tilde{s} \leq k$, after decoding $\tilde{u}_i^{N_{\tilde{s}}}$, first, the receiver tries to find a unique sequence $\tilde{v}_i^{N_{\tilde{s}}}$ satisfying (A62). If there exists such a unique $\tilde{v}_i^{N_{\tilde{s}}}$, put out the corresponding indexes \hat{i}_s^* , \hat{a}_s^* and \hat{b}_s^* . Otherwise, i.e., if no such sequence exists or multiple sequences have different message indices, declare a decoding error. After the receiver obtains the index \hat{b}_s^* , he also knows $(\hat{w}_{i,\tilde{s},p,2}^* \oplus k_{i,\tilde{s}}^*, \hat{w}_{i,\tilde{s},p,2}^{**})$ since it is the index of the bin which \hat{b}_s^* belongs to. Then, note that the receiver knows the secret key $k_{i,\tilde{s}}^*$, and thus he can directly obtain $\hat{w}_{i,\tilde{s},p,2} = (\hat{w}_{i,\tilde{s},p,2}^*, \hat{w}_{i,\tilde{s},p,2}^{**})$ from $(\hat{w}_{i,\tilde{s},p,2}^* \oplus k_{i,\tilde{s}}^*, \hat{w}_{i,\tilde{s},p,2}^{**})$ and the key $k_{i,\tilde{s}}^*$. Thus for $1 \leq \tilde{s} \leq k$, the receiver has an estimation $\hat{w}_{i,\tilde{s},p}$ of the private message $w_{i,\tilde{s},p}$ by letting $\hat{w}_{i,\tilde{s},p} = (\hat{a}_s^*, \hat{w}_{i,\tilde{s},p,2})$. If for all $1 \leq \tilde{s} \leq k$, there exist unique sequences $\tilde{v}_i^{N_{\tilde{s}}}$ such that (A62) is satisfied, the receiver declares that $\hat{w}_{i,p} = (\hat{w}_{i,1,p}, \hat{w}_{i,2,p}, \dots, \hat{w}_{i,k,p})$ is sent for block $2d + 1 \leq i \leq n$. Based on the AEP and $R_p(\tilde{s}) = I(V; Y|U, S, \tilde{S} = \tilde{s})$, it is easy to see that the error probability $Pr\{\hat{w}_{i,\tilde{s},p} \neq w_{i,\tilde{s},p}\}$ ($1 \leq \tilde{s} \leq k$) goes to 0.

- **(Decoding scheme for the eavesdropper):**

- **(Decoding the common message $w_{i,c}$ for block $1 \leq i \leq n$):** The delayed feedback state \tilde{S} at the transmitter, which is used to multiplex the component codewords, is also available at the eavesdropper. For block $1 \leq i \leq n$, once the eavesdropper receives \tilde{z}_i and the state sequence \tilde{s}_i , he first demultiplexes them into outputs corresponding to the component code-books and separately decodes each component codeword. To be specific, in each code-book $\mathcal{U}^{\tilde{s}}$, the eavesdropper has $(\tilde{z}_i^{N_{\tilde{s}}}, \tilde{s}_i^{N_{\tilde{s}}})$ and tries to search a unique $\tilde{u}_i^{N_{\tilde{s}}}$ such that

$$(\tilde{u}_i^{N_{\tilde{s}}}, \tilde{z}_i^{N_{\tilde{s}}}, \tilde{s}_i^{N_{\tilde{s}}}) \in T_{UZS|\tilde{S}}^{N_{\tilde{s}}}(\epsilon). \quad (\text{A63})$$

If there exists such a unique $\tilde{u}_i^{N_{\tilde{s}}}$, put out the corresponding index $\check{w}_{i,\tilde{s},c}$. Otherwise, i.e., if no such sequence exists or multiple sequences have different message indices, declare a decoding error. If for all $1 \leq \tilde{s} \leq k$, there exist unique sequences $\tilde{u}_i^{N_{\tilde{s}}}$ satisfying (A63), the receiver declares that $\check{w}_{i,c} = (\check{w}_{i,1,c}, \check{w}_{i,2,c}, \dots, \check{w}_{i,k,c})$ is sent in block i . Based on the AEP and (A49), it is easy to see that the error probability $Pr\{\check{w}_{i,\tilde{s},c} \neq w_{i,\tilde{s},c}\}$ ($1 \leq \tilde{s} \leq k$) goes to 0.

- **(For block $1 \leq i \leq n$, given \tilde{z}_i , \tilde{u}_i , \tilde{s}_i and $w_{i,p,1}$, decoding \tilde{v}_i):** In each component code-book $\mathcal{V}^{\tilde{s}}$ ($1 \leq \tilde{s} \leq k$), given $\tilde{s}_i^{N_{\tilde{s}}}$, $\tilde{u}_i^{N_{\tilde{s}}}(w_{i,\tilde{s},c})$, $\tilde{z}_i^{N_{\tilde{s}}}$ and $w_{i,\tilde{s},p,1}$, the eavesdropper tries to find a unique \check{b}_s^* such that

$$(\tilde{v}_i^{N_{\tilde{s}}}(w_{i,\tilde{s},c}, w_{i,\tilde{s},p,1}, \check{b}_s^*), \tilde{u}_i^{N_{\tilde{s}}}(w_{i,\tilde{s},c}), \tilde{z}_i^{N_{\tilde{s}}}, \tilde{s}_i^{N_{\tilde{s}}}) \in T_{UVS|\tilde{S}}^{N_{\tilde{s}}}(\epsilon). \quad (\text{A64})$$

Since there are $2^{N_{\tilde{s}}I(V;Z|U,S,\tilde{S}=\tilde{s})}$ possible values of $\tilde{b}_{\tilde{s}}^*$ (see (A55)), based on the AEP, the error probability

$$Pr\{\tilde{b}_{\tilde{s}}^* \neq b_{\tilde{s}}^*\} \rightarrow 0. \quad (\text{A65})$$

- **(For block $2d + 1 \leq i \leq n$, given \tilde{v}_{i-d} , \tilde{z}_{i-d} and \tilde{S}_{i-d} , the eavesdropper's equivocation about the secret key:)** For block $2d + 1 \leq i \leq n$ and $\tilde{S} = \tilde{s}$, even the eavesdropper knows $\tilde{v}_i^{N_{\tilde{s}}}$, without the secret key $k_{i,\tilde{s}}^*$ he still can not obtain $w_{i,\tilde{s},p,2}$, and this is because $w_{i,\tilde{s},p,2} = (w_{i,\tilde{s},p,2}^* \oplus k_{i,\tilde{s}}^*, w_{i,\tilde{s},p,2}^{**})$. The eavesdropper can guess $k_{i,\tilde{s}}^*$ from $\tilde{v}_{i-d}^{N_{\tilde{s}}}$, $\tilde{z}_{i-d}^{N_{\tilde{s}}}$ and $\tilde{S}_{i-d}^{N_{\tilde{s}}}$, and his equivocation about the secret key $k_{i,\tilde{s}}^*$ can be bounded by the following balanced coloring lemma introduced by Ahlswede and Cai [39].

Lemma 1: (Balanced coloring lemma) Given $\tilde{S} = \tilde{s}$, for any $\epsilon, \delta > 0$, sufficiently large $N_{\tilde{s}}$, all $N_{\tilde{s}}$ -type $P_{VS\tilde{S}Y}(v, s, \tilde{s}, y)$ and all $\tilde{v}_{i-d}^{N_{\tilde{s}}}, \tilde{S}_{i-d}^{N_{\tilde{s}}} \in T_{VS|\tilde{S}}^{N_{\tilde{s}}}$ ($2d + 1 \leq i \leq n$), there exists a γ -coloring $c : T_{Y|V,S,\tilde{S}}^{N_{\tilde{s}}}(\tilde{v}_{i-d}^{N_{\tilde{s}}}, \tilde{S}_{i-d}^{N_{\tilde{s}}}, \tilde{s}) \rightarrow \{1, 2, \dots, \gamma\}$ of $T_{Y|V,S,\tilde{S}}^{N_{\tilde{s}}}(\tilde{v}_{i-d}^{N_{\tilde{s}}}, \tilde{S}_{i-d}^{N_{\tilde{s}}}, \tilde{s})$ such that for all joint $N_{\tilde{s}}$ -type $P_{VS\tilde{S}YZ}(v, s, \tilde{s}, y, z)$ with marginal distribution $P_{VS\tilde{S}Z}(v, s, \tilde{s}, z)$ and $\frac{|T_{Y|V,S,\tilde{S},Z}^{N_{\tilde{s}}}(\tilde{v}_{i-d}^{N_{\tilde{s}}}, \tilde{S}_{i-d}^{N_{\tilde{s}}}, \tilde{s}, \tilde{z}_{i-d}^{N_{\tilde{s}}})|}{\gamma} > 2^{N_{\tilde{s}}\epsilon}$, $\tilde{v}_{i-d}^{N_{\tilde{s}}}, \tilde{S}_{i-d}^{N_{\tilde{s}}}, \tilde{z}_{i-d}^{N_{\tilde{s}}} \in T_{VSZ|\tilde{S}}^{N_{\tilde{s}}}$,

$$|c^{-1}(k)| \leq \frac{|T_{Y|V,S,\tilde{S},Z}^{N_{\tilde{s}}}(\tilde{v}_{i-d}^{N_{\tilde{s}}}, \tilde{S}_{i-d}^{N_{\tilde{s}}}, \tilde{s}, \tilde{z}_{i-d}^{N_{\tilde{s}}})|(1 + \delta)}{\gamma}, \quad (\text{A66})$$

for $k = 1, 2, \dots, \gamma$, where c^{-1} is the inverse image of c .

Proof: See [39, p. 260]. ■

Lemma 1 shows that given $\tilde{S} = \tilde{s}$, if $\tilde{v}_{i-d}^{N_{\tilde{s}}}, \tilde{S}_{i-d}^{N_{\tilde{s}}}, \tilde{y}_{i-d}^{N_{\tilde{s}}}$ and $\tilde{z}_{i-d}^{N_{\tilde{s}}}$ are jointly typical, for given $\tilde{v}_{i-d}^{N_{\tilde{s}}}, \tilde{S}_{i-d}^{N_{\tilde{s}}}$ and $\tilde{z}_{i-d}^{N_{\tilde{s}}}$, the number of $\tilde{y}_{i-d}^{N_{\tilde{s}}} \in T_{Y|V,S,\tilde{S},Z}^{N_{\tilde{s}}}(\tilde{v}_{i-d}^{N_{\tilde{s}}}, \tilde{S}_{i-d}^{N_{\tilde{s}}}, \tilde{s}, \tilde{z}_{i-d}^{N_{\tilde{s}}})$ for a certain color k ($k = 1, 2, \dots, \gamma$), which is denoted as $|c^{-1}(k)|$, is upper bounded by $\frac{|T_{Y|V,S,\tilde{S},Z}^{N_{\tilde{s}}}(\tilde{v}_{i-d}^{N_{\tilde{s}}}, \tilde{S}_{i-d}^{N_{\tilde{s}}}, \tilde{s}, \tilde{z}_{i-d}^{N_{\tilde{s}}})|(1 + \delta)}{\gamma}$. By using Lemma 1, it is easy to see that the typical set $T_{Y|V,S,\tilde{S},Z}^{N_{\tilde{s}}}(\tilde{v}_{i-d}^{N_{\tilde{s}}}, \tilde{S}_{i-d}^{N_{\tilde{s}}}, \tilde{s}, \tilde{z}_{i-d}^{N_{\tilde{s}}})$ maps into at least

$$\frac{|T_{Y|V,S,\tilde{S},Z}^{N_{\tilde{s}}}(\tilde{v}_{i-d}^{N_{\tilde{s}}}, \tilde{S}_{i-d}^{N_{\tilde{s}}}, \tilde{s}, \tilde{z}_{i-d}^{N_{\tilde{s}}})|}{\frac{|T_{Y|V,S,\tilde{S},Z}^{N_{\tilde{s}}}(\tilde{v}_{i-d}^{N_{\tilde{s}}}, \tilde{S}_{i-d}^{N_{\tilde{s}}}, \tilde{s}, \tilde{z}_{i-d}^{N_{\tilde{s}}})|(1 + \delta)}{\gamma}} = \frac{\gamma}{1 + \delta} \quad (\text{A67})$$

colors. On the other hand, the typical set $T_{Y|V,S,\tilde{S},Z}^{N_{\tilde{s}}}(\tilde{v}_{i-d}^{N_{\tilde{s}}}, \tilde{S}_{i-d}^{N_{\tilde{s}}}, \tilde{s}, \tilde{z}_{i-d}^{N_{\tilde{s}}})$ maps into at most γ colors. Thus, given $\tilde{S} = \tilde{s}$, $\tilde{V}_{i-d}^{N_{\tilde{s}}}, \tilde{Z}_{i-d}^{N_{\tilde{s}}}, \tilde{S}_{i-d}^{N_{\tilde{s}}}$, the eavesdropper's equivocation $H(K_{i,\tilde{s}}^* | \tilde{V}_{i-d}^{N_{\tilde{s}}}, \tilde{S}_{i-d}^{N_{\tilde{s}}}, \tilde{Z}_{i-d}^{N_{\tilde{s}}})$ about the secret key $K_{i,\tilde{s}}^*$ is lower bounded by

$$H(K_{i,\tilde{s}}^* | \tilde{V}_{i-d}^{N_{\tilde{s}}}, \tilde{S}_{i-d}^{N_{\tilde{s}}}, \tilde{Z}_{i-d}^{N_{\tilde{s}}}, \tilde{S} = \tilde{s}) \geq \log \frac{\gamma}{1 + \delta}. \quad (\text{A68})$$

Here note that in our encoding scheme, $\gamma = 2^{N_{\tilde{s}}R_f(\tilde{s})}$ for case 1, and $\gamma = 2^{N_{\tilde{s}}R_f^*(\tilde{s})}$ for case 2, see (A57) and (A58). Then, it is easy to see that (A68) can be re-written as follows. For case 1,

$$H(K_{i,\tilde{s}}^* | \tilde{V}_{i-d}^{N_{\tilde{s}}}, \tilde{S}_{i-d}^{N_{\tilde{s}}}, \tilde{Z}_{i-d}^{N_{\tilde{s}}}, \tilde{S} = \tilde{s}) \geq N_{\tilde{s}}R_f(\tilde{s}) - \log(1 + \delta), \quad (\text{A69})$$

and for case 2,

$$H(K_{i,\tilde{s}}^* | \tilde{V}_{i-d}^{N_{\tilde{s}}}, \tilde{S}_{i-d}^{N_{\tilde{s}}}, \tilde{Z}_{i-d}^{N_{\tilde{s}}}, \tilde{S} = \tilde{s}) \geq N_{\tilde{s}}R_f^*(\tilde{s}) - \log(1 + \delta). \quad (\text{A70})$$

Now it remains to show that $R_e = I(V; Y|U, S, \tilde{S}) - I(V; Z|U, S, \tilde{S}) + R_f$ for case 1 and $R_e = R_f^*$ for case 2, see the followings.

E. Equivocation analysis:

Equivocation analysis for case 1: For all blocks, the equivocation Δ is bounded by

$$\begin{aligned}
\Delta &= \frac{1}{nN} H(W|Z^n, S^n) = \frac{1}{nN} H(W_c, W_p|Z^n, S^n) \\
&\geq \frac{1}{nN} H(W_p|Z^n, S^n, W_c) \geq \frac{1}{nN} H(W_p|Z^n, S^n, W_c, U^n) \\
&\stackrel{(a)}{=} \frac{1}{nN} H(W_p|Z^n, S^n, U^n) = \frac{1}{nN} H(W_{1,p}, \dots, W_{n,p}|Z^n, S^n, U^n) \\
&= \frac{1}{nN} \sum_{i=1}^n H(W_{i,p}|Z^n, S^n, U^n, W_{1,p}, \dots, W_{i-1,p}) \\
&= \frac{1}{nN} \left(\sum_{i=1}^{2d} H(W_{i,p}|Z^n, S^n, U^n, W_{1,p}, \dots, W_{i-1,p}) \right. \\
&\quad \left. + \sum_{i=2d+1}^n H(W_{i,p}|Z^n, S^n, U^n, W_{1,p}, \dots, W_{i-1,p}) \right) \\
&\stackrel{(b)}{=} \frac{1}{nN} \left(\sum_{i=1}^{2d} H(W_{i,p}|\tilde{Z}_i, \tilde{S}_i, \tilde{U}_i) + \sum_{i=2d+1}^n H(W_{i,p}|\tilde{Z}_i, \tilde{S}_i, \tilde{U}_i, \tilde{Z}_{i-d}, \tilde{S}_{i-d}, \tilde{U}_{i-d}) \right) \\
&\stackrel{(c)}{\geq} \frac{1}{nN} \sum_{i=2d+1}^n H(W_{i,p}|\tilde{Z}_i, \tilde{S}_i, \tilde{U}_i, \tilde{Z}_{i-d}, \tilde{S}_{i-d}, \tilde{U}_{i-d}) \\
&= \frac{1}{nN} \sum_{i=2d+1}^n \sum_{\tilde{s}=1}^k H(W_{i,\tilde{s},p}|W_{i,1,p}, \dots, W_{i,\tilde{s}-1,p}, \tilde{Z}_i, \tilde{S}_i, \tilde{U}_i, \tilde{Z}_{i-d}, \tilde{S}_{i-d}, \tilde{U}_{i-d}) \\
&\stackrel{(d)}{=} \frac{1}{nN} \sum_{i=2d+1}^n \sum_{\tilde{s}=1}^k H(W_{i,\tilde{s},p}|\tilde{Z}_i^{N_{\tilde{s}}}, \tilde{S}_i^{N_{\tilde{s}}}, \tilde{U}_i^{N_{\tilde{s}}}, \tilde{Z}_{i-d}^{N_{\tilde{s}}}, \tilde{S}_{i-d}^{N_{\tilde{s}}}, \tilde{U}_{i-d}^{N_{\tilde{s}}}) \\
&= \frac{1}{nN} \sum_{i=2d+1}^n \sum_{\tilde{s}=1}^k H(W_{i,\tilde{s},p,1}, W_{i,\tilde{s},p,2}|\tilde{Z}_i^{N_{\tilde{s}}}, \tilde{S}_i^{N_{\tilde{s}}}, \tilde{U}_i^{N_{\tilde{s}}}, \tilde{Z}_{i-d}^{N_{\tilde{s}}}, \tilde{S}_{i-d}^{N_{\tilde{s}}}, \tilde{U}_{i-d}^{N_{\tilde{s}}}) \\
&\stackrel{(e)}{=} \frac{1}{nN} \sum_{i=2d+1}^n \sum_{\tilde{s}=1}^k (H(W_{i,\tilde{s},p,1}|\tilde{Z}_i^{N_{\tilde{s}}}, \tilde{S}_i^{N_{\tilde{s}}}, \tilde{U}_i^{N_{\tilde{s}}}) \\
&\quad + H(W_{i,\tilde{s},p,2}|W_{i,\tilde{s},p,1}, \tilde{Z}_i^{N_{\tilde{s}}}, \tilde{S}_i^{N_{\tilde{s}}}, \tilde{U}_i^{N_{\tilde{s}}}, \tilde{Z}_{i-d}^{N_{\tilde{s}}}, \tilde{S}_{i-d}^{N_{\tilde{s}}}, \tilde{U}_{i-d}^{N_{\tilde{s}}}), \tag{A71}
\end{aligned}$$

where (a) is from the definition $W_{i,p} = (W_{i,1,p}, W_{i,2,p}, \dots, W_{i,k,p})$ ($1 \leq i \leq n$), (b) is from the Markov chains $W_{i,p} \rightarrow (\tilde{Z}_i, \tilde{S}_i, \tilde{U}_i) \rightarrow (W_{1,p}, \dots, W_{i-1,p}, \tilde{Z}^{i-1}, \tilde{Z}_{i+1}^n, \tilde{U}^{i-1}, \tilde{U}_{i+1}^n, \tilde{S}^{i-1}, \tilde{S}_{i+1}^n)$ for block $1 \leq i \leq 2d$, and $W_{i,p} \rightarrow (\tilde{Z}_i, \tilde{S}_i, \tilde{U}_i, \tilde{Z}_{i-d}, \tilde{S}_{i-d}, \tilde{U}_{i-d}) \rightarrow (W_{1,p}, \dots, W_{i-1,p}, \tilde{Z}^{i-d-1}, \tilde{Z}_{i-d+1}^{i-1}, \tilde{Z}_{i+1}^n, \tilde{U}^{i-d-1}, \tilde{U}_{i-d+1}^{i-1}, \tilde{U}_{i+1}^n, \tilde{S}^{i-d-1}, \tilde{S}_{i-d+1}^{i-1}, \tilde{S}_{i+1}^n)$ for block $2d+1 \leq i \leq n$, (c) is from the fact that when n and N tend to infinity, $\frac{1}{nN} \sum_{i=1}^{2d} H(W_{i,p}|\tilde{Z}_i, \tilde{S}_i, \tilde{U}_i)$ tends to zero, and thus we can drop it, (d) is from the Markov chain $W_{i,\tilde{s},p} \rightarrow (\tilde{Z}_i^{N_{\tilde{s}}}, \tilde{S}_i^{N_{\tilde{s}}}, \tilde{U}_i^{N_{\tilde{s}}}, \tilde{Z}_{i-d}^{N_{\tilde{s}}}, \tilde{S}_{i-d}^{N_{\tilde{s}}}, \tilde{U}_{i-d}^{N_{\tilde{s}}}) \rightarrow (W_{i,1,p}, \dots, W_{i,\tilde{s}-1,p}, \tilde{Z}_i^{N_1}, \dots, \tilde{Z}_i^{N_{\tilde{s}-1}}, \tilde{Z}_i^{N_{\tilde{s}+1}}, \dots, \tilde{Z}_i^{N_k}, \tilde{U}_i^{N_1}, \dots, \tilde{U}_i^{N_{\tilde{s}-1}}, \tilde{U}_i^{N_{\tilde{s}+1}}, \dots, \tilde{U}_i^{N_k}, \tilde{S}_i^{N_1}, \dots, \tilde{S}_i^{N_{\tilde{s}-1}}, \tilde{S}_i^{N_{\tilde{s}+1}}, \dots, \tilde{S}_i^{N_k}, \tilde{Z}_{i-d}^{N_1}, \dots, \tilde{Z}_{i-d}^{N_{\tilde{s}-1}}, \tilde{Z}_{i-d}^{N_{\tilde{s}+1}}, \dots, \tilde{Z}_{i-d}^{N_k}, \tilde{U}_{i-d}^{N_1}, \dots, \tilde{U}_{i-d}^{N_{\tilde{s}-1}}, \tilde{U}_{i-d}^{N_{\tilde{s}+1}}, \dots, \tilde{U}_{i-d}^{N_k}, \tilde{S}_{i-d}^{N_1}, \dots, \tilde{S}_{i-d}^{N_{\tilde{s}-1}}, \tilde{S}_{i-d}^{N_{\tilde{s}+1}}, \dots, \tilde{S}_{i-d}^{N_k})$, which implies

the \tilde{s} -th component of the private message $W_{i,p}$ is only related with the \tilde{s} -th component of $\tilde{U}_i, \tilde{S}_i, \tilde{Z}_i, \tilde{U}_{i-d}, \tilde{S}_{i-d}$ and \tilde{Z}_{i-d} , and (e) is from the Markov chain $W_{i,\tilde{s},p,1} \rightarrow (\tilde{Z}_i^{N_{\tilde{s}}}, \tilde{S}_i^{N_{\tilde{s}}}, \tilde{U}_i^{N_{\tilde{s}}}) \rightarrow (\tilde{Z}_{i-d}^{N_{\tilde{s}}}, \tilde{S}_{i-d}^{N_{\tilde{s}}}, \tilde{U}_{i-d}^{N_{\tilde{s}}})$.

Now it remains for us to bound the conditional entropies $H(W_{i,\tilde{s},p,1}|\tilde{Z}_i^{N_{\tilde{s}}}, \tilde{S}_i^{N_{\tilde{s}}}, \tilde{U}_i^{N_{\tilde{s}}})$ and $H(W_{i,\tilde{s},p,2}|W_{i,\tilde{s},p,1}, \tilde{Z}_i^{N_{\tilde{s}}}, \tilde{S}_i^{N_{\tilde{s}}}, \tilde{U}_i^{N_{\tilde{s}}}, \tilde{Z}_{i-d}^{N_{\tilde{s}}}, \tilde{S}_{i-d}^{N_{\tilde{s}}}, \tilde{U}_{i-d}^{N_{\tilde{s}}})$ in (A71), see the followings.

The conditional entropy $H(W_{i,\tilde{s},p,1}|\tilde{Z}_i^{N_{\tilde{s}}}, \tilde{S}_i^{N_{\tilde{s}}}, \tilde{U}_i^{N_{\tilde{s}}})$ can be bounded by

$$\begin{aligned}
& H(W_{i,\tilde{s},p,1}|\tilde{Z}_i^{N_{\tilde{s}}}, \tilde{S}_i^{N_{\tilde{s}}}, \tilde{U}_i^{N_{\tilde{s}}}) \geq H(W_{i,\tilde{s},p,1}|\tilde{Z}_i^{N_{\tilde{s}}}, \tilde{S}_i^{N_{\tilde{s}}}, \tilde{U}_i^{N_{\tilde{s}}}, \tilde{S} = \tilde{s}) \\
& = H(W_{i,\tilde{s},p,1}, \tilde{Z}_i^{N_{\tilde{s}}}, \tilde{S}_i^{N_{\tilde{s}}}, \tilde{U}_i^{N_{\tilde{s}}}, \tilde{S} = \tilde{s}) - H(\tilde{Z}_i^{N_{\tilde{s}}}, \tilde{S}_i^{N_{\tilde{s}}}, \tilde{U}_i^{N_{\tilde{s}}}, \tilde{S} = \tilde{s}) \\
& = H(\tilde{V}_i^{N_{\tilde{s}}}, W_{i,\tilde{s},p,1}, \tilde{Z}_i^{N_{\tilde{s}}}, \tilde{S}_i^{N_{\tilde{s}}}, \tilde{U}_i^{N_{\tilde{s}}}, \tilde{S} = \tilde{s}) - H(\tilde{V}_i^{N_{\tilde{s}}}|W_{i,\tilde{s},p,1}, \tilde{Z}_i^{N_{\tilde{s}}}, \tilde{S}_i^{N_{\tilde{s}}}, \tilde{U}_i^{N_{\tilde{s}}}, \tilde{S} = \tilde{s}) - H(\tilde{Z}_i^{N_{\tilde{s}}}, \tilde{S}_i^{N_{\tilde{s}}}, \tilde{U}_i^{N_{\tilde{s}}}, \tilde{S} = \tilde{s}) \\
& \stackrel{(f)}{=} H(\tilde{Z}_i^{N_{\tilde{s}}}|\tilde{V}_i^{N_{\tilde{s}}}, \tilde{S}_i^{N_{\tilde{s}}}, \tilde{U}_i^{N_{\tilde{s}}}, \tilde{S} = \tilde{s}) + H(\tilde{V}_i^{N_{\tilde{s}}}, W_{i,\tilde{s},p,1}, \tilde{S}_i^{N_{\tilde{s}}}, \tilde{U}_i^{N_{\tilde{s}}}, \tilde{S} = \tilde{s}) \\
& \quad - H(\tilde{V}_i^{N_{\tilde{s}}}|W_{i,\tilde{s},p,1}, \tilde{Z}_i^{N_{\tilde{s}}}, \tilde{S}_i^{N_{\tilde{s}}}, \tilde{U}_i^{N_{\tilde{s}}}, \tilde{S} = \tilde{s}) - H(\tilde{Z}_i^{N_{\tilde{s}}}, \tilde{S}_i^{N_{\tilde{s}}}, \tilde{U}_i^{N_{\tilde{s}}}, \tilde{S} = \tilde{s}) \\
& \stackrel{(g)}{=} N_{\tilde{s}}H(Z|V, U, S, \tilde{S} = \tilde{s}) + H(\tilde{V}_i^{N_{\tilde{s}}}|S_i^{N_{\tilde{s}}}, \tilde{U}_i^{N_{\tilde{s}}}, \tilde{S} = \tilde{s}) - H(\tilde{Z}_i^{N_{\tilde{s}}}|S_i^{N_{\tilde{s}}}, \tilde{U}_i^{N_{\tilde{s}}}, \tilde{S} = \tilde{s}) \\
& \quad - H(\tilde{V}_i^{N_{\tilde{s}}}|W_{i,\tilde{s},p,1}, \tilde{Z}_i^{N_{\tilde{s}}}, \tilde{S}_i^{N_{\tilde{s}}}, \tilde{U}_i^{N_{\tilde{s}}}, \tilde{S} = \tilde{s}) \\
& \geq N_{\tilde{s}}H(Z|V, U, S, \tilde{S} = \tilde{s}) + H(\tilde{V}_i^{N_{\tilde{s}}}|S_i^{N_{\tilde{s}}}, \tilde{U}_i^{N_{\tilde{s}}}, \tilde{S} = \tilde{s}) - N_{\tilde{s}}H(Z|U, S, \tilde{S} = \tilde{s}) \\
& \quad - H(\tilde{V}_i^{N_{\tilde{s}}}|W_{i,\tilde{s},p,1}, \tilde{Z}_i^{N_{\tilde{s}}}, \tilde{S}_i^{N_{\tilde{s}}}, \tilde{U}_i^{N_{\tilde{s}}}, \tilde{S} = \tilde{s}) \\
& \stackrel{(h)}{\geq} N_{\tilde{s}}I(V; Y|U, S, \tilde{S} = \tilde{s}) - 1 - N_{\tilde{s}}I(V; Z|U, S, \tilde{S} = \tilde{s}) - H(\tilde{V}_i^{N_{\tilde{s}}}|W_{i,\tilde{s},p,1}, \tilde{Z}_i^{N_{\tilde{s}}}, \tilde{S}_i^{N_{\tilde{s}}}, \tilde{U}_i^{N_{\tilde{s}}}, \tilde{S} = \tilde{s}) \\
& \stackrel{(i)}{\geq} N_{\tilde{s}}I(V; Y|U, S, \tilde{S} = \tilde{s}) - 1 - N_{\tilde{s}}I(V; Z|U, S, \tilde{S} = \tilde{s}) - N_{\tilde{s}}\epsilon_1, \tag{A72}
\end{aligned}$$

where (f) is from the fact that $H(W_{i,\tilde{s},p,1}|\tilde{V}_i^{N_{\tilde{s}}}) = 0$, (g) is also from $H(W_{i,\tilde{s},p,1}|\tilde{V}_i^{N_{\tilde{s}}}) = 0$ and the fact that the channel is a DMC with transition probability $P_{Y,Z|X,S}(y, z|x, s)$, and for each \tilde{s} , $X^{N_{\tilde{s}}}$ is i.i.d. generated according to a new DMC with transition probability $P_{X|U,V,\tilde{S}}(x|u, v, \tilde{s})$, thus we have $H(\tilde{Z}_i^{N_{\tilde{s}}}|S_i^{N_{\tilde{s}}}, \tilde{U}_i^{N_{\tilde{s}}}, \tilde{S} = \tilde{s}) = N_{\tilde{s}}H(Z|V, U, S, \tilde{S} = \tilde{s})$, (h) is from the fact that for given \tilde{s} , $\tilde{u}_i^{N_{\tilde{s}}}$ and $\tilde{s}_i^{N_{\tilde{s}}}$, $\tilde{V}_i^{N_{\tilde{s}}}$ has $A_{\tilde{s}} \cdot B_{\tilde{s}}$ possible values, using a similar lemma in [13], we have

$$H(\tilde{V}_i^{N_{\tilde{s}}}|S_i^{N_{\tilde{s}}}, \tilde{U}_i^{N_{\tilde{s}}}, \tilde{S} = \tilde{s}) \geq \log A_{\tilde{s}} + \log B_{\tilde{s}} - 1 \stackrel{(1)}{=} N_{\tilde{s}}I(V; Y|U, S, \tilde{S} = \tilde{s}) - 1, \tag{A73}$$

where (1) is from (A54) and (A55), and (i) is from the fact that given \tilde{s} , $w_{i,\tilde{s},p,1}, \tilde{z}_i^{N_{\tilde{s}}}, \tilde{s}_i^{N_{\tilde{s}}}$ and $\tilde{u}_i^{N_{\tilde{s}}}$, the eavesdropper's decoding error probability of $\tilde{v}_i^{N_{\tilde{s}}}$ tends to zero (see (A65)), then, by using Fano's inequality, we have

$$\frac{1}{N_{\tilde{s}}}H(\tilde{V}_i^{N_{\tilde{s}}}|W_{i,\tilde{s},p,1}, \tilde{Z}_i^{N_{\tilde{s}}}, \tilde{S}_i^{N_{\tilde{s}}}, \tilde{U}_i^{N_{\tilde{s}}}, \tilde{S} = \tilde{s}) \leq \epsilon_1, \tag{A74}$$

where $\epsilon_1 \rightarrow 0$ as $N_{\tilde{s}} \rightarrow \infty$.

The conditional entropy $H(W_{i,\tilde{s},p,2}|W_{i,\tilde{s},p,1}, \tilde{Z}_i^{N_{\tilde{s}}}, \tilde{S}_i^{N_{\tilde{s}}}, \tilde{U}_i^{N_{\tilde{s}}}, \tilde{Z}_{i-d}^{N_{\tilde{s}}}, \tilde{S}_{i-d}^{N_{\tilde{s}}}, \tilde{U}_{i-d}^{N_{\tilde{s}}})$ can be bounded by

$$\begin{aligned}
& H(W_{i,\tilde{s},p,2}|W_{i,\tilde{s},p,1}, \tilde{Z}_i^{N_{\tilde{s}}}, \tilde{S}_i^{N_{\tilde{s}}}, \tilde{U}_i^{N_{\tilde{s}}}, \tilde{Z}_{i-d}^{N_{\tilde{s}}}, \tilde{S}_{i-d}^{N_{\tilde{s}}}, \tilde{U}_{i-d}^{N_{\tilde{s}}}) \\
& \geq H(W_{i,\tilde{s},p,2}|W_{i,\tilde{s},p,1}, \tilde{Z}_i^{N_{\tilde{s}}}, \tilde{S}_i^{N_{\tilde{s}}}, \tilde{U}_i^{N_{\tilde{s}}}, \tilde{Z}_{i-d}^{N_{\tilde{s}}}, \tilde{S}_{i-d}^{N_{\tilde{s}}}, \tilde{U}_{i-d}^{N_{\tilde{s}}}, W_{i,\tilde{s},p,2}^* \oplus K_{i,\tilde{s}}^*, \tilde{S} = \tilde{s}, \tilde{V}_i^{N_{\tilde{s}}}, \tilde{V}_{i-d}^{N_{\tilde{s}}}) \\
& \stackrel{(j)}{=} H(W_{i,\tilde{s},p,2}|\tilde{Z}_{i-d}^{N_{\tilde{s}}}, \tilde{S}_{i-d}^{N_{\tilde{s}}}, \tilde{U}_{i-d}^{N_{\tilde{s}}}, W_{i,\tilde{s},p,2}^* \oplus K_{i,\tilde{s}}^*, \tilde{S} = \tilde{s}, \tilde{V}_{i-d}^{N_{\tilde{s}}})
\end{aligned}$$

$$\begin{aligned}
&\stackrel{(k)}{=} H(W_{i,\tilde{s},p,2}|\tilde{Z}_{i-d}^{N_{\tilde{s}}}, \tilde{S}_{i-d}^{N_{\tilde{s}}}, W_{i,\tilde{s},p,2}^* \oplus K_{i,\tilde{s}}^*, \tilde{S} = \tilde{s}, \tilde{V}_{i-d}^{N_{\tilde{s}}}) \\
&= H(K_{i,\tilde{s}}^*|\tilde{Z}_{i-d}^{N_{\tilde{s}}}, \tilde{S}_{i-d}^{N_{\tilde{s}}}, W_{i,\tilde{s},p,2}^* \oplus K_{i,\tilde{s}}^*, \tilde{S} = \tilde{s}, \tilde{V}_{i-d}^{N_{\tilde{s}}}) \\
&\stackrel{(l)}{=} H(K_{i,\tilde{s}}^*|\tilde{Z}_{i-d}^{N_{\tilde{s}}}, \tilde{S}_{i-d}^{N_{\tilde{s}}}, \tilde{V}_{i-d}^{N_{\tilde{s}}}, \tilde{S} = \tilde{s}) \\
&\stackrel{(m)}{\geq} N_{\tilde{s}}R_f(\tilde{s}) - \log(1 + \delta), \tag{A75}
\end{aligned}$$

where (j) is from the Markov chain $W_{i,\tilde{s},p,2} \rightarrow (\tilde{Z}_{i-d}^{N_{\tilde{s}}}, \tilde{S}_{i-d}^{N_{\tilde{s}}}, \tilde{U}_{i-d}^{N_{\tilde{s}}}, W_{i,\tilde{s},p,2}^* \oplus K_{i,\tilde{s}}^*, \tilde{S} = \tilde{s}, \tilde{V}_{i-d}^{N_{\tilde{s}}}) \rightarrow (W_{i,\tilde{s},p,1}, \tilde{Z}_i^{N_{\tilde{s}}}, \tilde{S}_i^{N_{\tilde{s}}}, \tilde{U}_i^{N_{\tilde{s}}}, \tilde{V}_i^{N_{\tilde{s}}})$, (k) is from the fact that $H(\tilde{U}_{i-d}^{N_{\tilde{s}}}|\tilde{V}_{i-d}^{N_{\tilde{s}}}) = 0$, (l) is from the Markov chain $W_{i,\tilde{s},p,2}^* \oplus K_{i,\tilde{s}}^* \rightarrow (\tilde{Z}_{i-d}^{N_{\tilde{s}}}, \tilde{S}_{i-d}^{N_{\tilde{s}}}, \tilde{V}_{i-d}^{N_{\tilde{s}}}, \tilde{S} = \tilde{s}) \rightarrow K_{i,\tilde{s}}^*$, and (m) is from (A69).

Substituting (A72) and (A75) into (A71), we have

$$\begin{aligned}
\Delta &\geq \frac{1}{nN} \sum_{i=2d+1}^n \sum_{\tilde{s}=1}^k [N_{\tilde{s}}I(V; Y|U, S, \tilde{S} = \tilde{s}) - 1 - N_{\tilde{s}}I(V; Z|U, S, \tilde{S} = \tilde{s}) - N_{\tilde{s}}\epsilon_1 + N_{\tilde{s}}R_f(\tilde{s}) - \log(1 + \delta)] \\
&= \frac{1}{nN} \sum_{i=2d+1}^n \sum_{\tilde{s}=1}^k [N_{\tilde{s}}(I(V; Y|U, S, \tilde{S} = \tilde{s}) - I(V; Z|U, S, \tilde{S} = \tilde{s}) + R_f(\tilde{s}) - \epsilon_1) - 1 - \log(1 + \delta)] \\
&\stackrel{(n)}{=} \frac{1}{nN} \sum_{i=2d+1}^n \sum_{\tilde{s}=1}^k [N(\pi(\tilde{s}) - \epsilon') (I(V; Y|U, S, \tilde{S} = \tilde{s}) - I(V; Z|U, S, \tilde{S} = \tilde{s}) + R_f(\tilde{s}) - \epsilon_1) - 1 - \log(1 + \delta)] \\
&= \frac{n-2d}{nN} \sum_{\tilde{s}=1}^k [N\pi(\tilde{s})(I(V; Y|U, S, \tilde{S} = \tilde{s}) - I(V; Z|U, S, \tilde{S} = \tilde{s}) + R_f(\tilde{s})) - N\pi(\tilde{s})\epsilon_1 \\
&\quad - N\epsilon' (I(V; Y|U, S, \tilde{S} = \tilde{s}) - I(V; Z|U, S, \tilde{S} = \tilde{s}) + R_f(\tilde{s})) + N\epsilon'\epsilon_1 - 1 - \log(1 + \delta)] \\
&\stackrel{(o)}{=} I(V; Y|U, S, \tilde{S}) - I(V; Z|U, S, \tilde{S}) + R_f - \frac{2d}{n} (I(V; Y|U, S, \tilde{S}) - I(V; Z|U, S, \tilde{S}) + R_f) - \frac{n-2d}{n}\epsilon_1 \sum_{\tilde{s}=1}^k \pi(\tilde{s}) \\
&\quad - \frac{n-2d}{n}\epsilon' \sum_{\tilde{s}=1}^k (I(V; Y|U, S, \tilde{S} = \tilde{s}) - I(V; Z|U, S, \tilde{S} = \tilde{s}) + R_f(\tilde{s})) \\
&\quad + \frac{n-2d}{n}k(\epsilon'\epsilon_1 - \frac{1 + \log(1 + \delta)}{N}), \tag{A76}
\end{aligned}$$

where (n) is from (A43), and (o) is from (A59). Thus, choosing sufficiently large n and N (here note that ϵ' and ϵ_1 tend to zero while $N \rightarrow \infty$), $\Delta \geq I(V; Y|U, S, \tilde{S}) - I(V; Z|U, S, \tilde{S}) + R_f - \epsilon$ is proved.

Equivocation analysis for case 2: For the case 2, (A47) implies that the private message $W_{i,p,1} = (W_{i,1,p,1}, \dots, W_{i,k,p,1})$ of block i is a constant, and thus the conditional entropy $H(W_{i,\tilde{s},p,1}|\tilde{Z}_i^{N_{\tilde{s}}}, \tilde{S}_i^{N_{\tilde{s}}}, \tilde{U}_i^{N_{\tilde{s}}})$ of (A71) satisfies

$$H(W_{i,\tilde{s},p,1}|\tilde{Z}_i^{N_{\tilde{s}}}, \tilde{S}_i^{N_{\tilde{s}}}, \tilde{U}_i^{N_{\tilde{s}}}) = 0. \tag{A77}$$

Moreover, using (A70), the last step of (A75) can be re-written by

$$\begin{aligned}
&H(W_{i,\tilde{s},p,2}|W_{i,\tilde{s},p,1}, \tilde{Z}_i^{N_{\tilde{s}}}, \tilde{S}_i^{N_{\tilde{s}}}, \tilde{U}_i^{N_{\tilde{s}}}, \tilde{Z}_{i-d}^{N_{\tilde{s}}}, \tilde{S}_{i-d}^{N_{\tilde{s}}}, \tilde{U}_{i-d}^{N_{\tilde{s}}}) \\
&\geq N_{\tilde{s}}R_f^*(\tilde{s}) - \log(1 + \delta). \tag{A78}
\end{aligned}$$

Substituting (A77) and (A78) into (A71), we have

$$\begin{aligned}
\Delta &\geq \frac{1}{nN} \sum_{i=2d+1}^n \sum_{\tilde{s}=1}^k (N_{\tilde{s}} R_f^*(\tilde{s}) - \log(1 + \delta)) \\
&= \frac{1}{nN} \sum_{i=2d+1}^n \sum_{\tilde{s}=1}^k (N(\pi(\tilde{s}) - \epsilon') R_f^*(\tilde{s}) - \log(1 + \delta)) \\
&= \frac{n-2d}{nN} (N \sum_{\tilde{s}=1}^k \pi(\tilde{s}) R_f^*(\tilde{s}) - N \epsilon' \sum_{\tilde{s}=1}^k R_f^*(\tilde{s}) - k \log(1 + \delta)) \\
&\stackrel{(1)}{=} \frac{n-2d}{n} R_f^* - \frac{n-2d}{n} \epsilon' \sum_{\tilde{s}=1}^k R_f^*(\tilde{s}) - \frac{n-2d}{n} \frac{\log(1 + \delta)}{N} k, \tag{A79}
\end{aligned}$$

where (1) is from (A60). Thus, choosing sufficiently large n and N (here note that ϵ' tends to zero while $N \rightarrow \infty$), $\Delta \geq R_f^* - \epsilon$ is proved.

Thus, the achievability proof of $\mathcal{R}^{fi\circ}$ for both cases are completed. Finally, using Fourier-Motzkin elimination to eliminate R_c and R_p from $\mathcal{R}^{fi\circ}$, \mathcal{R}^{fi} is obtained. The proof of Theorem 3 is completed.

APPENDIX E

PROOF OF THEOREM 4

Since $R_e \leq R$ is obvious, we only need to prove the inequalities $R \leq I(V; Y|S, \tilde{S})$ and $R_e \leq H(Y|Z, U, S, \tilde{S})$. Define the auxiliary random variables U, V, X, S, \tilde{S}, Y and Z the same as those in (A24). Then it is easy to see that the proof of $R \leq I(V; Y|S, \tilde{S})$ is exactly the same as that in (A36). Now it remains to show $R_e \leq H(Y|Z, U, S, \tilde{S})$, see the followings.

By using (2.9) and (2.10), we have

$$\begin{aligned}
R_e - \epsilon &\stackrel{(1)}{\leq} \frac{1}{N} H(W|Z^N, S^N) \\
&= \frac{1}{N} (H(W|Z^N, S^N) - H(W|Z^N, S^N, Y^N) + H(W|Z^N, S^N, Y^N)) \\
&\stackrel{(2)}{\leq} \frac{1}{N} I(W; Y^N|Z^N, S^N) + \frac{\delta(P_e)}{N} \\
&\leq \frac{1}{N} H(Y^N|Z^N, S^N) + \frac{\delta(P_e)}{N} \\
&= \frac{1}{N} \sum_{i=1}^N H(Y_i|Y^{i-1}, Z^N, S^N) + \frac{\delta(P_e)}{N} \\
&\stackrel{(3)}{\leq} \frac{1}{N} \sum_{i=1}^N H(Y_i|Y^{i-1}, Z_{i+1}^N, S^N, Z_i, S_i, S_{i-d}) + \frac{\delta(P_e)}{N} \\
&\stackrel{(4)}{=} H(Y|U, Z, S, \tilde{S}) + \frac{\delta(P_e)}{N} \\
&\stackrel{(5)}{\leq} H(Y|U, Z, S, \tilde{S}) + \frac{\delta(\epsilon)}{N}, \tag{A80}
\end{aligned}$$

where (1) from (2.10), and (2) is from the Fano's inequality, (3) is from the fact that S_i and S_{i-d} (here $S_{i-d} = \text{const}$ when $i \leq d$) are included in S^N , (4) is from the definitions in (A24) and the fact that J is a random variable

(uniformly distributed over $\{1, 2, \dots, N\}$), and it is independent of Y^N , Z^N , W and S^N , and (5) is from $\delta(P_e)$ is increasing while P_e is increasing, and $P_e \leq \epsilon$.

Letting $\epsilon \rightarrow 0$, $R_e \leq H(Y|Z, U, S, \tilde{S})$ is proved, and the proof of Theorem 4 is completed.

APPENDIX F PROOF OF (2.19)

A. Achievability proof of (2.19)

Replacing V^N by X^N , and letting W_e, U^N be constants, the achievability of \mathcal{R}^{fi*} is along the lines of the proof of Theorem 3 for case 1, where

$$\begin{aligned} \mathcal{R}^{fi*} &= \{(R, R_e) : 0 \leq R_e \leq R, \\ &R \leq I(X; Y|S, \tilde{S}), \\ &R_e \leq I(X; Y|S, \tilde{S}) - I(X; Z|S, \tilde{S}) + H(Y|X, Z, S, \tilde{S})\}. \end{aligned}$$

Here note that since Z is a degraded version of Y ,

$$\begin{aligned} &I(X; Y|S, \tilde{S}) - I(X; Z|S, \tilde{S}) + H(Y|X, Z, S, \tilde{S}) \\ &= H(X|S, \tilde{S}) - H(X|S, \tilde{S}, Y) - H(X|S, \tilde{S}) + H(X|S, \tilde{S}, Z) + H(Y|X, Z, S, \tilde{S}) \\ &\stackrel{(1)}{=} H(X|S, \tilde{S}, Z) - H(X|S, \tilde{S}, Y, Z) + H(Y|X, Z, S, \tilde{S}) \\ &= I(X; Y|S, \tilde{S}, Z) + H(Y|X, Z, S, \tilde{S}) \\ &= H(Y|S, \tilde{S}, Z), \end{aligned}$$

where (1) is from the Markov chain $X \rightarrow (S, \tilde{S}, Y) \rightarrow Z$. Thus, it is easy to see that $\mathcal{R}^{fi*} = \mathcal{R}^{f*}$, and the achievability of (2.19) is completed.

B. Converse proof of (2.19)

Since $R_e \leq R$ is obvious and the proof of $R \leq I(X; Y|S, \tilde{S})$ is exactly the same as that in Appendix C (see (A36)), it remains to show that $R_e \leq H(Y|S, \tilde{S}, Z)$, see the followings.

Note that

$$\begin{aligned} R_e - \epsilon &\stackrel{(1)}{\leq} \frac{H(W|Z^N, S^N)}{N} \\ &= \frac{1}{N}(H(W|Z^N, S^N) - H(W|Z^N, S^N, Y^N) + H(W|Z^N, S^N, Y^N)) \\ &\stackrel{(2)}{\leq} \frac{1}{N}(I(W; Y^N|Z^N, S^N) + \delta(P_e)) \\ &\leq \frac{1}{N}(H(Y^N|Z^N, S^N) + \delta(P_e)) \\ &\stackrel{(3)}{=} \frac{1}{N} \sum_{i=1}^N H(Y_i|Y^{i-1}, Z^N, S^N, S_i, S_{i-d}) + \frac{\delta(P_e)}{N} \end{aligned}$$

$$\begin{aligned}
&\leq \frac{1}{N} \sum_{i=1}^N H(Y_i|Z_i, S_i, S_{i-d}) + \frac{\delta(P_e)}{N} \\
&\stackrel{(4)}{=} \frac{1}{N} \sum_{i=1}^N H(Y_i|Z_i, S_i, S_{i-d}, J=i) + \frac{\delta(P_e)}{N} \\
&\stackrel{(5)}{=} H(Y_J|Z_J, S_J, S_{J-d}, J) + \frac{\delta(P_e)}{N} \\
&\stackrel{(6)}{\leq} H(Y_J|Z_J, S_J, S_{J-d}) + \frac{\delta(\epsilon)}{N} \\
&\stackrel{(7)}{=} H(Y|Z, S, \tilde{S}) + \frac{\delta(\epsilon)}{N}, \tag{A81}
\end{aligned}$$

where (1) is from (2.10), (2) is from Fano's inequality, (3) is from the fact that S_i and S_{i-d} (here $S_{i-d} = \text{const}$ when $i \leq d$) are included in S^N , (4) and (5) are from the fact that J is a random variable (uniformly distributed over $\{1, 2, \dots, N\}$), and it is independent of Y^N, Z^N, W and S^N , (6) is from $P_e \leq \epsilon$ and $\delta(P_e)$ is increasing while P_e is increasing, and (7) is from the definitions in (A24).

Letting $\epsilon \rightarrow 0$, $R_e \leq H(Y|Z, S, \tilde{S})$ is proved. The converse and entire proof of (2.19) is completed.

REFERENCES

- [1] H. S. Wang and N. Moayeri, "Finite-state markov channel-A useful model for radio communication channels," *IEEE Trans. Veh. Technol.*, vol. 44, pp. 163-171, 1995.
- [2] Q. Zhang and S. Kassam, "Finite-state Markov model for Rayleigh fading channels," *IEEE Trans. Commun.*, vol. 47, no. 11, pp. 1688-1692, 1999.
- [3] A. J. Goldsmith and P. P. Varaiya, "Capacity, mutual information, and coding for finite-state Markov channels," *IEEE Trans. Inf. Theory*, vol. IT-42, pp. 868-886, 1996.
- [4] H. Viswanathan, "Capacity of Markov channels with receiver CSI and delayed feedback," *IEEE Trans. Inf. Theory*, vol. IT-45, no. 2, pp. 761-771, 1999.
- [5] U. Basher, A. Shirazi and H. H. Permuter, "Capacity region of finite state multiple-access channels with delayed state information at the Transmitters," *IEEE Trans. Inf. Theory*, vol. IT-58, no. 6, pp. 3430-3452, 2012.
- [6] J. Chen and T. Berger, "The capacity of finite-state Markov channels with feedback," *IEEE Trans. Inf. Theory*, vol. IT-51, pp. 780-789, 2005.
- [7] H. H. Permuter and T. Weissman, "Capacity region of the finite-state multiple access channel with and without feedback," *IEEE Trans. Inf. Theory*, vol. IT-55, no. 6, 2009.
- [8] H. H. Permuter, T. Weissman, and A. J. Goldsmith, "Finite state channels with time-invariant deterministic feedback," *IEEE Trans. Inf. Theory*, vol. IT-55, pp. 644-662, 2009.
- [9] G. Como and S. Yüksel, "On the capacity of finite state multiple access channels with asymmetric partial state feedback," in *WiOPT09: Proc. 7th Int. Conf. Modeling and Optimization in Mobile, Ad Hoc, and Wireless Networks*, IEEE Press, Piscataway, NJ, 2009, pp. 589-594.
- [10] A. J. Goldsmith and P. P. Varaiya, "Capacity of fading channels with channel side information," *IEEE Trans. Inf. Theory*, vol. IT-43, pp. 1986-1992, 1997.
- [11] A. D. Wyner, "The wire-tap channel," *The Bell System Technical Journal*, vol. 54, no. 8, pp. 1355-1387, 1975.
- [12] S. K. Leung-Yan-Cheong, M. E. Hellman, "The Gaussian wire-tap channel," *IEEE Trans. Inf. Theory*, vol. IT-24, no. 4, pp. 451-456, July 1978.
- [13] I. Csiszár and J. Körner, "Broadcast channels with confidential messages," *IEEE Trans. Inf. Theory*, vol. IT-24, no. 3, pp. 339-348, May 1978.
- [14] Y. Liang, H. V. Poor and S. Shamai, "Secure communication over fading channels," *IEEE Trans. Inf. Theory*, vol. IT-54, pp. 2470-2492, 2008.

- [15] R. Liu, I. Maric, P. Spasojevic and R. D. Yates, "Discrete memoryless interference and broadcast channels with confidential messages: secrecy rate regions," *IEEE Trans. Inf. Theory*, vol. IT-54, no. 6, pp. 2493-2507, Jun. 2008.
- [16] J. Xu, Y. Cao, and B. Chen, "Capacity bounds for broadcast channels with confidential messages," *IEEE Trans. Inf. Theory*, vol. IT-55, no. 6, pp. 4529-4542. 2009.
- [17] Y. Liang and H. V. Poor, "Multiple-access channels with confidential messages," *IEEE Trans. Inf. Theory*, vol. IT-54, no. 3, pp. 976-1002, Mar. 2008.
- [18] E. Tekin and A. Yener, "The Gaussian multiple access wire-tap channel," *IEEE Trans. Inf. Theory*, vol. IT-54, no. 12, pp. 5747-5755, Dec. 2008.
- [19] E. Tekin and A. Yener, "The general Gaussian multiple access and two-way wire-tap channels: Achievable rates and cooperative jamming," *IEEE Trans. Inf. Theory*, vol. IT-54, no. 6, pp. 2735-2751, June 2008.
- [20] M. Wiese and H. Boche, "An Achievable Region for the Wiretap Multiple-Access Channel with Common Message," *Proceedings of 2012 IEEE International Symposium on Information Theory*, 2012.
- [21] M. H. Yassaee and M. R. Aref, "Multiple access wiretap channels with strong secrecy," *Proceedings of IEEE Information Theory Workshop*, 2010.
- [22] P. Xu, Z. Ding, and X. Dai, "Rate Regions for Multiple Access Channel With Conference and Secrecy Constraints," *IEEE Trans. Inf. Forensics and Security*, vol. 8, no. 12, pp. 1961-1974, 2013.
- [23] Z. H. Awan, A. Zaidi and L. Vandendorpe, "Multi-access Channel with Partially Cooperating Encoders and Security Constraints," *IEEE Trans. Inf. Forensics and Security*, Vol. 8, No. 7, pp. 1243-1254, Jul. 2013.
- [24] X. Tang, R. Liu, P. Spasojević and H. V. Poor, "Interference assisted secret communication," *IEEE Trans. Inf. Theory*, vol. IT-57, no. 5, pp. 3153-3167, May 2011.
- [25] Y. Liang, A. Somekh-Baruch, H. V. Poor, S. Shamai, and S. Verdú, "Capacity of cognitive interference channels with and without secrecy," *IEEE Trans. Inf. Theory*, vol. IT-55, pp. 604-619, 2009.
- [26] L. Lai and H. El Gamal, "The relay-eavesdropper channel: cooperation for secrecy," *IEEE Trans. Inf. Theory*, vol. IT-54, no. 9, pp. 4005-4019, Sep. 2008.
- [27] B. Dai and Z. Ma, "Multiple-access relay wiretap channel," *IEEE Trans. Inf. Forensics and Security*, vol. 10, no. 9, pp. 1835-1849, Sep. 2015.
- [28] Y. Oohama, "Coding for relay channels with confidential messages," in *Proceedings of IEEE Information Theory Workshop*, Australia, 2001.
- [29] B. Dai, L. Yu and Z. Ma, "Relay broadcast channel with confidential messages," *IEEE Trans. Inf. Forensics and Security*, vol. 11, no. 2, pp. 410-425, 2016.
- [30] E. Ekrem and S. Ulukus, "Secrecy in cooperative relay broadcast channels," *IEEE Trans. Inf. Theory*, vol. IT-57, pp. 137-155, 2011.
- [31] C. Mitrpant, A. J. Han Vinck and Y. Luo, "An Achievable Region for the Gaussian Wiretap Channel with Side Information," *IEEE Trans. Inf. Theory*, vol. IT-52, no. 5, pp. 2181-2190, 2006.
- [32] Y. Chen, A. J. Han Vinck, "Wiretap channel with side information," *IEEE Trans. Inf. Theory*, vol. IT-54, no. 1, pp. 395-402, January 2008.
- [33] M. El Halabi, T. Liu, C. N. Georghiades and S. Shamai, "Secret writing on dirty paper: a deterministic view," *IEEE Trans. Inf. Theory*, vol. IT-58, no. 6, pp. 3419-3429, June 2012.
- [34] Y. K. Chia and A. El Gamal, "Wiretap channel with causal state information," *IEEE Trans. Inf. Theory*, vol. 58, no. 5, pp. 2838-2849, May 2012.
- [35] B. Dai, Z. Ma and X. Fang, "Feedback Enhances the Security of State-Dependent Degraded Broadcast Channels With Confidential Messages," *IEEE Trans. Inf. Forensics and Security*, Vol. 10, No. 7, pp. 1529-1542, 2015.
- [36] M. Bloch and J. N. Lanema, "On the secrecy capacity of arbitrary wiretap channels," in *Proc. of 46th Allerton Conference on Communication, Control and Computing*, Monticello, IL, September 2008.
- [37] Y. Sankarasubramaniam, A. Thangaraj and K. Viswanathan, "Finite-state wiretap channels: secrecy under memory constraints," in *Proc. 2009 IEEE Information Theory Workshop*, Taormina, Italy, 2009, pp. 115-119.
- [38] M. Mushkin and I. Bar-David, "Capacity and coding for the Gilbert-Elliott channels," *IEEE Trans. Inf. Theory*, vol. 35, pp. 1277-1290, 1989.
- [39] R. Ahlswede and N. Cai, "Transmission, Identification and Common Randomness Capacities for Wire-Tap Channels with Secure Feedback

from the Decoder,” book chapter in *General Theory of Information Transfer and Combinatorics*, LNCS 4123, pp. 258-275, Berlin: Springer-Verlag, 2006.

[40] T. M. Cover and J. A. Thomas, *Elements of Information Theory*. New York, NY: Wiley-Interscience, 1991.

[41] S. Lall, “Advanced topics in computation for control,” Lecture notes for Engr210b, Stanford University, Fall, 2004.