

# An algorithm for the weighted metric dimension of two-dimensional grids

Ron Adar\*      Leah Epstein†

## Abstract

A two-dimensional grid consists of vertices of the form  $(i, j)$  for  $1 \leq i \leq m$  and  $1 \leq j \leq n$ , for fixed  $m, n \geq 2$ . Two vertices are adjacent if the  $\ell_1$  distance between their vectors is equal to 1. A landmark set is a subset of vertices  $L \subseteq V$ , such that for any distinct pair of vertices  $u, v \in V$ , there exists a vertex of  $L$  whose distances to  $u$  and  $v$  are not equal. We design an efficient algorithm for finding a minimum landmark set with respect to total cost in a grid graph with non-negative costs defined on the vertices.

## 1 Introduction

Consider an undirected graph  $G = (V, E)$ . For  $u, v \in V$ , let  $d(u, v)$  denote the edge distance between these two vertices. A vertex  $x \in V$  separates  $u$  and  $v$  if  $d(x, u) \neq d(x, v)$ , and in this case,  $x$  is also called a separating vertex for  $u$  and  $v$ . A landmark set is a subset  $L \subseteq V$  such that for any pair of vertices  $u \neq v$ ,  $L$  has at least one vertex  $y$  that separates  $u$  and  $v$ . The vertices of a landmark set  $L$  are often referred to as *landmarks*. In the algorithmic metric dimension problem, the goal is to find a landmark set  $L$  of minimum cardinality. In the weighted version of this problem, a non-negative cost (or weight) function  $c : V \rightarrow \mathbb{Q}^+$  is given. For  $U \subseteq V$ , the cost or weight of  $U$  is defined as  $c(U) = \sum_{a \in U} c(a)$ , and the goal is to find a landmark set  $L$  minimizing  $c(L)$ . The cardinality of a minimum cardinality landmark set of  $G$  is called the *metric dimension* of  $G$ , and the cost of a minimum cost landmark set is called the *weighted metric dimension* of  $G$ .

A two-dimensional grid with integer parameters  $m$  and  $n$  has  $|V| = m \cdot n$  vertices of the form  $(i, j)$ , where  $1 \leq i \leq m$  and  $1 \leq j \leq n$ . For vertices  $(i_1, j_1)$ ,  $(i_2, j_2)$ , let

---

\*Department of Computer Science, University of Haifa, Haifa, Israel. radar03@csweb.haifa.ac.il.

†Department of Mathematics, University of Haifa, Haifa, Israel. lea@math.haifa.ac.il.

$((i_1, j_1), (i_2, j_2)) \in E$  if (and only if)  $|i_1 - i_2| + |j_1 - j_2| = 1$ . The resulting distance between two vertices is the  $\ell_1$  distance between their vectors, that is,  $d((i_1, j_1), (i_2, j_2)) = |i_1 - i_2| + |j_1 - j_2|$ . This graph can be visualized on the plane, such that the rows are numbered from top to bottom, and its columns from left to right. The sides of the grid are the top row (row 1), the bottom row (row  $m$ ), the leftmost column (column 1), and the rightmost column (column  $n$ ). The  $j$ th vertex in the  $i$ th row of the grid is denoted by  $(i, j)$ . The vertices  $(1, 1)$ ,  $(1, n)$ ,  $(m, 1)$ , and  $(m, n)$  are called corners. That is, vertices of degree 2 are corners, and vertices of degrees below 4 belong to sides. Other vertices (of degree 4) are called internal. Since a minimum cardinality landmark set consists of a single vertex if and only if the graph is a path [12], and the case of a path (a one-dimensional grid) was completely studied [12, 9], we assume that  $m \geq 2$  and  $n \geq 2$ , and therefore any landmark set will have at least two vertices. Corners that belong to the same row or to the same column are called adjacent corners, and otherwise they are non-adjacent or opposite corners. Sides that share a corner are called adjacent sides, and otherwise they are non-adjacent or opposite sides. We assume that the vertex costs are given in a matrix of size  $\Theta(mn) = \Theta(|V|)$ , such that any specific cost (the value  $c(v)$  for a given vertex  $v$ ) can be retrieved in time  $O(1)$ . We let  $c_{i,j} = c((i, j))$  for any  $1 \leq i \leq m$  and  $1 \leq j \leq n$ . Let a double side consist of two adjacent sides, excluding their common corner. We say that two vertices  $x_1 = (y_1, z_1)$  and  $x_2 = (y_2, z_2)$  are *on a joint diagonal* if  $y_1 + z_1 = y_2 + z_2$ . Such pairs of vertices are of particular interest as we should be careful regarding separating them, and in particular, the corner vertex  $(1, 1)$  does not separate any such pair. For two vertices  $r_1 = (a_1, b_1)$  and  $r_2 = (a_2, b_2)$  such that  $a_1 \leq a_2$  and  $b_1 \leq b_2$ , we define the sub-grid of  $r_1$  and  $r_2$  as the set of all vertices whose first component is in  $[a_1, a_2]$  and their second component is in  $[b_1, b_2]$ .

In this work, we will use the standard term *minimal* for a landmark set that is minimal with respect to set inclusion. We will use the term *minimum* landmark set for a landmark set that is minimum with respect to cost. A minimum cardinality landmark set will be called *smallest*. As weights are non-negative, there always exists a minimum cost landmark set that is also a minimal landmark set. In some cases, when we search for a minimum landmark set, we will only consider minimal landmark sets as potential solutions. We will show, in particular, that the cardinality of a minimal landmark set is either a positive number in  $\{2, 4, \dots, 2 \cdot \min\{m, n\} - 2\}$  (note that the upper bound was shown in [1]), or it is equal to 3. We find that if  $m = n = 2$ , all minimal landmark sets have cardinality 2, if  $\min\{m, n\} = 2$  but  $\max\{m, n\} > 2$ , all minimal landmark sets have cardinalities of 2 and 3. We will show that any minimal landmark set of cardinality at least 4 has a specific form, and we use dynamic programming to find a subset of minimum cost of this form (there can be sets of this form that are landmark sets but they are not minimal landmark sets).

Moreover, it follows from our results that the case of cardinality 3 is the only possible case of an odd cardinality of a minimal landmark set. We also analyze minimal landmark sets of cardinalities 2 and 3. The result for cardinality 2 was obtained by Melter and Tomescu [13] (and generalized by Khuller, Raghavachari, and Rosenfeld [12]), where landmark sets of minimum cardinality were studied. The result for cardinality 3 was obtained in [1], where properties of some minimal landmark sets are studied. For completeness, and as the proofs some of these properties are used later as well, we provide complete proofs. These proofs are followed by efficient algorithms for finding such sets. Our main algorithm applies several algorithms and provides a minimum landmark set out of landmark sets of cardinalities 2, 3, and at least 4. The output, which is a set of minimum cost out of the outputs, is a minimum landmark set. Our main result is therefore an efficient (polynomial-time) algorithm for finding a minimum (i.e., minimum cost) landmark set in a two-dimensional grid graph. That is, we solve the algorithmic weighted metric dimension problem on two-dimensional grid graphs. The cases of landmark sets of cardinalities 2 and 3 are relatively simple, and the main technical difficulty is to find a minimum landmark set out of landmark sets of cardinality at least 4. We will observe that every such set is related to a sequence that follows a pattern, which we will call a zigzag sequence.

Another variant of grid graphs, where the distances are according to the  $\ell_\infty$  norm was studied [12, 14]. This first articles on the metric dimension problem were by Harary and Melter [10] and by Slater [16]. The problem is NP-hard [12] and hard to approximate [3, 8] for general graphs, and it was studied for specific graph classes [10, 16, 12, 5, 2, 15, 6, 4, 9]. Applications can be found in [3, 10, 13, 7, 12, 5], where some of these applications are relevant for weighted graphs (see also [9]).

## 2 Main result

We start with proving some simple but crucial properties.

**Lemma 1** *Any landmark set has at least one vertex of each double side.*

**Proof.** Without loss of generality consider the first row and the first column. We show that no vertex separates vertices  $(1, 2)$  and  $(2, 1)$  except for vertices of this double side. For any vertex  $(a, b)$  such that  $a \geq 2$  and  $b \geq 2$ , we find  $d((1, 2), (a, b)) = a + b - 3$  and  $d((2, 1), (a, b)) = a + b - 3$  (any such shortest path traverses  $(2, 2)$ ). Moreover,  $d((1, 2), (1, 1)) = 1$  and  $d((2, 1), (1, 1)) = 1$ . The remaining vertices are on the double side, where any such vertex has either  $a = 1$  and  $b > 1$  or it has  $a > 1$  and  $b = 1$ . If  $a = 1$  and  $b \neq 1$ , then  $d((1, 2), (a, b)) = b - 2$  and  $d((2, 1), (a, b)) = b$ , and if  $a \neq 1$  and  $b = 1$ , then

$d((1, 2), (a, b)) = a$  and  $d((2, 1), (a, b)) = a - 2$ . Therefore given a landmark set  $L$ , at least one vertex of the double side must belong to  $L$ . ■

**Lemma 2** *No minimal landmark set contains two opposite corners.*

**Proof.** Without loss of generality, consider the corners  $(1, 1)$  and  $(m, n)$ . For any  $x = (y, z)$ ,  $d(x, (1, 1)) = y + z - 2$  and  $d(x, (m, n)) = m + n - y - z$ . Thus, for any two vertices, their distances to  $(1, 1)$  are distinct if and only if their distances to  $(m, n)$  are distinct. ■

**Lemma 3** *For any landmark set, there is a pair of opposite sides of the grid such that each one of these sides has a landmark.*

**Proof.** If every side has a landmark, we are done. Otherwise, consider a side  $\Lambda$  without a landmark. Since every double side has a landmark, each one of the two sides adjacent to  $\Lambda$  has a landmark (and these are two distinct landmark as the two sides are disjoint). ■

As mentioned above, the following was proved in [13].

**Proposition 4** *A set that consists of exactly two vertices is a landmark set if and only if these two vertices are adjacent corners.*

**Proof.** First, note that a landmark set of cardinality 2 must be minimal as any landmark set for a graph that is not a path has cardinality of at least 2 [12].

Consider a set  $A = \{v_1 = (a_1, b_1), v_2 = (a_2, b_2)\}$ , where either  $a_1 \neq a_2$  or  $b_1 \neq b_2$  or both.

First, assume that  $v_1$  and  $v_2$  are adjacent corners, and without loss of generality,  $a_1 = a_2 = 1$ ,  $b_1 = 1$ , and  $b_2 = n$ . Consider two distinct vertices  $x_1 = (y_1, z_1)$  and  $x_2 = (y_2, z_2)$ . For  $i = 1, 2$ , we have  $d(x_i, v_1) = |y_i - a_1| + |z_i - b_1| = y_i + z_i - 2$ . If  $x_1$  and  $x_2$  are not on a joint diagonal,  $y_1 + z_1 \neq y_2 + z_2$ , and we have  $d(x_1, v_1) \neq d(x_2, v_1)$ , so  $v_1$  separates them. If  $x_1$  and  $x_2$  are on a joint diagonal, then for  $i = 1, 2$ , we have  $d(x_i, v_2) = |y_i - a_2| + |z_i - b_2| = y_i - 1 + m - z_i$ . Since  $y_1 + z_1 = y_2 + z_2$ , we have  $d(x_1, v_2) = y_1 - z_1 + m - 1 = y_2 + z_2 - 2z_1 + m - 1$  while  $d(x_2, v_2) = y_2 - z_2 + m - 1$ . If  $d(x_1, v_2) = d(x_2, v_2)$ , we get  $z_1 = z_2$ , and therefore by  $y_1 + z_1 = y_2 + z_2$ , we also find  $y_1 = y_2$ , proving  $x_1 = x_2$ . Thus, if  $x_1 \neq x_2$ , at least one of  $v_1$  or  $v_2$  separates them. This shows that  $A$  is a landmark set.

If  $v_1$  and  $v_2$  are opposite corners, then by Lemma 2 cannot be a minimal landmark set. Next, assume that at least one of  $v_1$  and  $v_2$  is not a corner. Assume without loss of generality that  $A$  does not contain any corner, except for possibly  $(1, 1)$ . If  $A$  contains a corner, the other vertex of  $A$  is a vertex of the double side consisting of the first row and the first column. This last vertex is not a corner by the assumption that  $(1, n), (m, 1), (m, n) \notin A$  (and since  $(1, 1)$  does not belong to this double side). In this case the landmark set has no

vertex of the double side consisting of the last row and the last column, contradicting the property that it is a landmark set.

If  $A$  does not contain any corner, then since any landmark set has a pair of vertices on opposite sides, its two vertices are on opposite sides. Assume without loss of generality (due to symmetry) that  $A = \{(1, z), (m, z')\}$ , where  $2 \leq z \leq z' \leq m-1$ . If  $z = z'$ , then  $d((1, z-1), (1, z)) = 1$ ,  $d((1, z+1), (1, z)) = 1$ ,  $d((1, z-1), (m, z)) = m$ , and  $d((1, z+1), (m, z)) = m$ , so no vertex of  $A$  separates  $(1, z-1)$  and  $(1, z+1)$ . Otherwise,  $d((1, z+1), (1, z)) = 1$ ,  $d((2, z), (1, z)) = 1$ ,  $d((1, z+1), (m, z')) = m+z'-z-2$ , and  $d((2, z), (m, z')) = m+z'-z-2$ , so no vertex of  $A$  separates  $(1, z+1)$  and  $(2, z)$ . ■

**Lemma 5** *Let  $z$  satisfy  $1 \leq z < n$ , and let  $(a, b)$  be a vertex that separates the vertices  $(1, z+1)$  and  $(2, z)$ . If  $b \leq z$ , then  $a > 1$  and if  $b \geq z+1$ , then  $a = 1$ .*

**Proof.** If  $b \leq z$  and  $a = 1$ , then  $d((1, z+1), (a, b)) = d((2, z), (a, b)) = 1 + z - b$ . This is a contradiction to the role of  $(a, b)$  as a separating vertex for  $(1, z+1)$  and  $(2, z)$ , and therefore in the case  $b \leq z$ , we have  $a > 1$ . Otherwise, assume that  $b \geq z+1$  holds. We have  $d((1, z+1), (a, b)) = a - 1 + b - z - 1 = a + b - z - 2$ ,  $d((2, z), (a, b)) = |a - 2| + b - z$ . Thus, as  $(a, b)$  separates these two vertices,  $a = 1$ . ■

In the next lemma we consider a sub-grid of two vertices  $(a_1, b_1)$ ,  $(a_2, b_2)$  such that  $a_1 \leq a_2$  and  $b_1 \leq b_2$ , and a vertex  $(a, b)$  that is either on the left hand side of this sub-grid ( $b \leq b_1$  and  $a_1 < a \leq a_2$ ) or it is above this sub-grid ( $a \leq a_1$  and  $b_1 < b \leq b_2$ ). We also consider the smaller sub-grid whose upper left corner is  $(a, b_1)$  in the first case and  $(a_1, b)$  in the second case, and the other corner remains  $(a_2, b_2)$ . We show that  $(a, b)$  separates any pair of vertices on a joint diagonal that are not both vertices of the smaller sub-grid.

**Lemma 6** *Let  $(a_1, b_1)$ ,  $(a_2, b_2)$  be grid vertices such that  $a_1 \leq a_2$  and  $b_1 \leq b_2$ . Let  $u = (a, b)$  be a vertex such that either  $a_1 < a \leq a_2$  and  $b \leq b_1$  hold or  $a \leq a_1$  and  $b_1 < b \leq b_2$  hold. Then,  $(a, b)$  separates any pair of distinct vertices  $v_1 = (x_1, y_1)$  and  $v_2 = (x_2, y_2)$  that are on a joint diagonal and  $x_1 < x_2$  (so  $x_1 + y_1 = x_2 + y_2$  and  $y_1 > y_2$  hold) under the required conditions, where the conditions on  $(a, b)$  are as follows. In the first option for  $(a, b)$ , it holds that  $a_1 \leq x_1 < a$ ,  $x_1 < x_2 \leq a_2$ , and  $b_1 \leq y_2 < y_1 \leq b_2$ , and in the second option for  $(a, b)$ , it holds that  $a_1 \leq x_1 < x_2 \leq a_2$ ,  $b_1 \leq y_2 < b$ , and  $y_2 < y_1 \leq b_2$ .*

**Proof.** If  $a_1 = a_2$  or  $b_1 = b_2$ , there are no such pairs  $v_1, v_2$ . Thus we assume  $a_1 < a_2$  and  $b_1 < b_2$ . Since the two options for  $(a, b)$  are analogous, we will prove the property for the first option.

We have  $|x_1 - a| = a - x_1$ ,  $|y_1 - b| = y_1 - b$ , and  $|y_2 - b| = y_2 - b$ . Thus,  $d(v_1, u) = y_1 - x_1 + a - b$  and  $d(v_2, u) = |x_2 - a| + y_2 - b$ . Assume by contradiction that  $d(v_1, u) = d(v_2, u)$ . We get  $|x_2 - a| = y_1 - x_1 - y_2 + a$ , and by using  $x_1 + y_1 = x_2 + y_2$ , we have  $|x_2 - a| = x_2 - 2x_1 + a$ .

If  $x_2 \leq a$ , this implies  $x_1 = x_2$ , a contradiction. If  $x_2 > a$ , this implies  $a = x_1$ , a contradiction as well. ■

Obviously, in the case  $a = a_2$  and  $b \leq b_1$ , and in the case  $a \leq a_1$  and  $b = b_2$ , the lemma shows that  $(a, b)$  separates any pair of vertices on a joint diagonal of the sub-grid of  $(a_1, b_1)$  and  $(a_2, b_2)$ .

In the next lemma we show that it is possible that while every pair of vertices should be separated by any landmark set, it is possible to restrict the set of pairs that should be tested. More precisely, given two landmarks on opposite sides (we consider the case of the top row and the bottom row, such that the vertex of the top row is strictly to the left of the vertex of the bottom row), creating a sub-grid, it will be sufficient to ensure for every pair of vertices on a joint diagonal, both being vertices of the sub-grid, are separated.

**Lemma 7** *Consider  $X \subseteq V$ , where  $X$  contains two side vertices (of opposite sides)  $t_1 = (1, z_1)$ ,  $t_2 = (m, z_2)$  such that  $1 \leq z_1 < z_2 \leq n$ . If for any pair of vertices on a joint diagonal of the sub-grid of  $t_1$  and  $t_2$ ,  $(a_1, b_1)$  and  $(a_2, b_2)$  such that  $a_1 < a_2$  (so  $a_1 + b_1 = a_2 + b_2$  and  $z_1 \leq b_2 < b_1 \leq z_2$ ),  $X$  has a vertex that separates  $(a_1, b_1)$  and  $(a_2, b_2)$ , then  $X$  is a landmark set.*

**Proof.** If  $X$  contains a vertex of the form  $(1, z')$  such that  $z_1 < z' < z_2$ , it is sufficient to prove the claim for  $(1, z')$  and  $(m, z_2)$  (and this will imply the claim for  $(1, z_1)$  and  $(m, z_2)$ ). Thus, without loss of generality we will assume that no such vertex belongs to  $X$ . Similarly, we assume that no vertex of the form  $(m, z')$  with  $z_1 < z' < z_2$  belongs to  $X$ .

Consider the vertices  $(1, z_1 + 1)$  and  $(2, z_1)$ . These vertices are on a joint diagonal and they are vertices of the considered sub-grid, and thus by the conditions of the lemma,  $X$  has a vertex that separates them. Let this vertex be  $(a, b)$ . By Lemma 5, none of  $t_1$  and  $t_2$  separates these two vertices, and thus  $(a, b)$  is another vertex satisfying  $a = 1$  and  $b \geq z_2$  or  $a > 1$  and  $b \leq z_1$  (the case where  $z_1 + 1 \leq b \leq z_1 - 1$  is impossible since in this case  $a = 1$  and we assume that no vertex  $(1, z')$  with  $z_1 < z' < z_2$  belongs to  $X$ ).

Let  $v_1 = (x_1, y_1)$  and  $v_2 = (x_2, y_2)$ , such that  $y_1 \leq y_2$  be a pair of distinct vertices. Assume that they are not separated by  $(1, z_1)$ , by  $(m, z_2)$ , or by  $(a, b)$ . That is, we assume  $d(v_1, (1, z_1)) = d(v_2, (1, z_1))$ ,  $d(v_1, (m, z_2)) = d(v_2, (m, z_2))$  and  $d(v_1, (a, b)) = d(v_2, (a, b))$ . We find  $d(v_i, (1, z_1)) = x_i - 1 + |y_i - z_1|$  and  $d(v_i, (m, z_2)) = m - x_i + |y_i - z_2|$ . If  $(a, b)$  is such that  $a = 1$  and  $b \geq z_2$ , then  $d(v_i, (a, b)) = x_i - 1 + |y_i - b|$ , and otherwise  $d(v_i, (a, b)) = |x_i - a| + |y_i - b|$ .

We consider all possible cases with respect to the columns of  $v_1$  and  $v_2$ .

**Case 1.** In this case either  $y_1 \leq y_2 < z_1$  or  $z_2 < y_1 \leq y_2$  holds. That is, both  $v_1$  and  $v_2$  are not vertices of the sub-grid, and they are on the same side of the sub-grid (either to the left or to the right of it, see for example the blue vertices in figure 1).

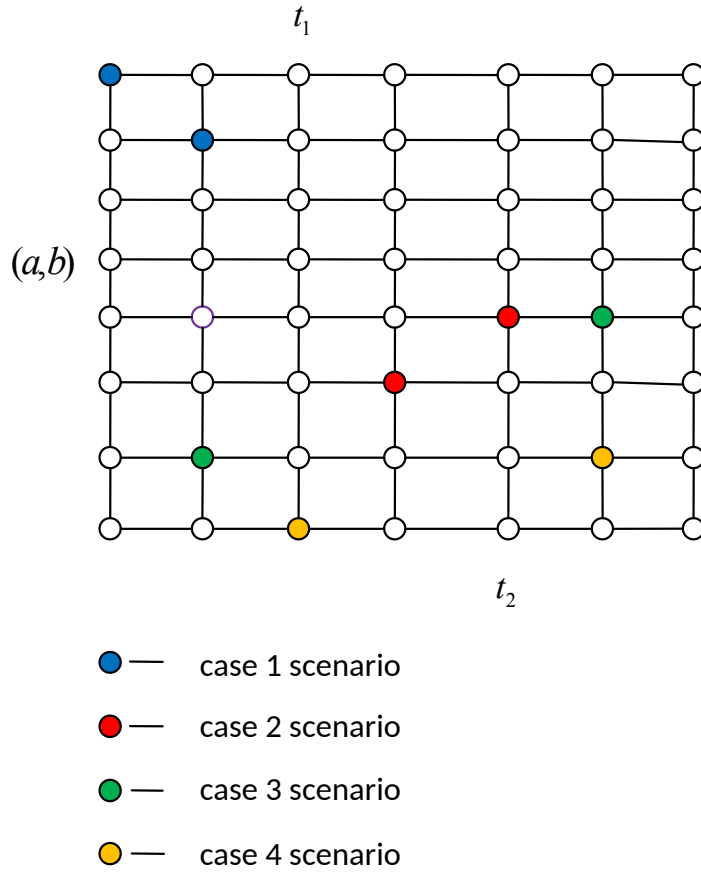

Figure 1: An example of a grid with 8 rows and 7 columns. All possible cases of  $v_1$  and  $v_2$  described in the proof of Lemma 7, for the sub-grid of  $t_1 = (1, 3)$  and  $t_2 = (8, 5)$ , where  $(a, b) = (4, 1)$  is a vertex separating (for example) the pair  $(2, 3), (1, 4)$  and the pair  $(5, 3), (3, 5)$ , but it does not separate the pair  $(5, 3), (4, 4)$ .

If  $y_2 < z_1$ , we have  $d(v_i, (1, z_1)) = x_i - 1 + z_1 - y_i$  and  $d(v_i, (m, z_2)) = m - x_i + z_2 - y_i$ . We find  $x_1 - y_1 = x_2 - y_2$  and  $x_1 + y_1 = x_2 + y_2$ . Similarly, if  $y_1 > z_2$ , we have  $d(v_i, (1, z_1)) = x_i - 1 + y_i - z_1$  and  $d(v_i, (m, z_2)) = m - x_i + y_i - z_2$ , and in this case We find  $x_1 - y_1 = x_2 - y_2$  and  $x_1 + y_1 = x_2 + y_2$  hold as well. In both cases we find that  $x_1 = x_2$  and  $y_1 = y_2$  hold, contradicting the property that  $v_1 \neq v_2$ .

**Case 2.** In this case  $z_1 \leq y_1 \leq y_2 \leq z_2$  holds. That is, both vertices are vertices of the sub-grid (see for example the red vertices in figure 1).

We have  $d(v_i, (1, z_1)) = x_i - 1 + y_i - z_1$ , and therefore  $x_1 + y_1 = x_2 + y_2$  holds. In this case  $v_1$  and  $v_2$  are on a joint diagonal of the sub-grid, and by assumption there is a vertex of  $X$  separating them.

**Case 3.** In this case  $y_1 < z_1$  and  $y_2 > z_2$ , that is, both  $v_1$  and  $v_2$  are not vertices of the sub-grid, one of them ( $v_1$ ) is to the left of the sub-grid and the other one ( $v_2$ ) is on the right (see for example the green vertices in figure 1).

We have  $d(v_1, (1, z_1)) = x_1 - 1 + z_1 - y_1$ ,  $d(v_2, (1, z_1)) = x_2 - 1 + y_2 - z_1$ ,  $d(v_1, (m, z_2)) = m - x_1 + z_2 - y_1$ , and  $d(v_2, (m, z_2)) = m - x_2 + y_2 - z_2$ . This proves  $x_1 + z_1 - y_1 = x_2 + y_2 - z_1$  and  $x_1 + y_1 - z_2 = x_2 - y_2 + z_2$ . Taking the sum and difference we get  $x_1 - x_2 = z_2 - z_1 > 0$  (so  $x_1 > x_2$ ) and  $y_1 + y_2 = z_1 + z_2$ .

Let  $(a', b') \in X$  be a vertex that separates the vertices  $(x_2, z_1 + 1)$  and  $(x_2 + 1, z_1)$ . These are vertices of  $G$  since  $x_2 + 1 \leq x_1$  and  $z_1 + 1 \leq z_2$ . These two vertices are vertices of the sub-grid on a joint diagonal, and therefore  $(a', b')$  exists according to the conditions of the lemma. First, we analyze the values of  $a'$  and  $b'$ . If  $a' \leq x_2$  and  $b' \leq z_1$ , we find  $d((x_2, z_1 + 1), (a', b')) = x_2 - a' + z_1 + 1 - b'$  and  $d((x_2 + 1, z_1), (a', b')) = x_2 + 1 - a' + z_1 - b'$ , so  $(a', b')$  does not separate the two vertices. If  $a' \geq x_2 + 1$  and  $b' \geq z_1 + 1$ , we find  $d((x_2, z_1 + 1), (a', b')) = a' - x_2 + b' - z_1 - 1$  and  $d((x_2 + 1, z_1), (a', b')) = a' - x_2 - 1 + b' - z_1$ , so  $(a', b')$  does not separate the two vertices. Thus either  $a' \leq x_2$  and  $b' \geq z_1 + 1$  hold or  $a' \geq x_2 + 1$  and  $b' \leq z_1$  hold.

We consider the two cases. In the first case, by  $x_1 > x_2 \geq a'$  and  $y_1 < z_1 < b'$ , we have  $d(v_1, (a', b')) = x_1 - a' + b' - y_1$ . Moreover,  $d(v_2, (a', b')) = x_2 - a' + |y_2 - b'|$ . These two values are distinct since if  $y_2 \geq b'$ , then  $x_1 - x_2 + b' - y_1 - |y_2 - b'| = x_1 - x_2 - y_1 - y_2 + 2b' = (z_2 - z_1) - (z_1 + z_2) + 2b' = 2(b' - z_1) > 0$ , and if  $y_2 \leq b'$ , then  $x_1 - x_2 + b' - y_1 - |y_2 - b'| = x_1 - x_2 - y_1 + y_2 = (z_2 - z_1) + y_2 - (z_1 + z_2 - y_2) = 2(y_2 - z_1) > 0$ , since  $y_2 > z_2 > z_1 > y_1$ .

In the second case, by  $x_2 \leq a' - 1 < a'$  and  $b' \leq z_1 < y_2$ , we have  $d(v_2, (a', b')) = a' - x_2 + y_2 - b'$ . We show that the two values  $d(v_1, (a', b'))$  and  $d(v_2, (a', b'))$  are distinct.

If  $y_1 \leq b'$  and  $x_1 \leq a'$ ,  $d(v_1, (a', b')) = a' - x_1 + b' - y_1$ . The two distances are distinct since we have  $x_1 + y_1 + y_2 - x_2 - 2b' = z_2 - z_1 + z_1 + z_2 - 2b' = 2(z_2 - b') > 0$ , since  $z_2 > z_1 \geq b'$ .

If  $y_1 \leq b'$  and  $x_1 \geq a' + 1$ ,  $d(v_1, (a', b')) = x_1 - a' + b' - y_1$ . The two distances are distinct since we have  $y_1 - x_1 + y_2 - x_2 + 2a' - 2b' = (z_1 + z_2) - 2x_2 + z_1 - z_2 + 2a' - 2b' = 2(z_1 - x_2 + a' - b') > 0$  since  $a' \geq x_2 + 1$  and  $z_1 \geq b'$ .

If  $y_1 \geq b' + 1$  and  $x_1 \leq a'$ ,  $d(v_1, (a', b')) = a' - x_1 + y_1 - b'$ . The two distances are distinct since we have  $-y_1 + x_1 + y_2 - x_2 = z_2 - z_1 + 2y_2 - z_1 - z_2 = 2(y_2 - z_1) > 0$  (by  $y_2 > z_2 > z_1$ ).

If  $y_1 \geq b' + 1$  and  $x_1 \geq a' + 1$ ,  $d(v_1, (a', b')) = x_1 - a' + y_1 - b'$ . The two distances are distinct since we have  $-y_1 - x_1 + 2a' + y_2 - x_2 = z_1 + z_2 - 2y_1 + 2a' - 2x_2 + z_2 - z_1 = 2(z_2 - y_1 + a' - x_2) > 0$  since  $a' \geq x_2 + 1$  and  $z_2 > y_1$ .

**Case 4.** In this case we either have  $y_1 < z_1$  and  $z_1 \leq y_2 \leq z_2$  or we have  $z_1 \leq y_1 \leq z_2$  and  $y_2 > z_2$ . That is, one vertex is a vertex of the sub-grid, while the other one is not a



vertex of the sub-grid (see for example the yellow vertices in figure 1).

In the first option, we have  $d(v_1, (1, z_1)) = x_1 - 1 + z_1 - y_1$ ,  $d(v_2, (1, z_1)) = x_2 - 1 + y_2 - z_1$ ,  $d(v_1, (m, z_2)) = m - x_1 + z_2 - y_1$ , and  $d(v_2, (m, z_2)) = m - x_2 + z_2 - y_2$ . This proves  $x_1 + z_1 - y_1 = x_2 + y_2 - z_1$  and  $x_1 + y_1 = x_2 + y_2$ . The two properties together imply  $y_1 = z_1$ , which is a contradiction. In the second option, we have  $d(v_1, (1, z_1)) = x_1 - 1 + y_1 - z_1$ ,  $d(v_2, (1, z_1)) = x_2 - 1 + y_2 - z_1$ ,  $d(v_1, (m, z_2)) = m - x_1 + z_2 - y_1$ , and  $d(v_2, (m, z_2)) = m - x_2 + y_2 - z_2$ . This proves  $x_1 + y_1 = x_2 + y_2$  and  $x_1 + y_1 - z_2 = x_2 - y_2 + z_2$ . The two properties together imply  $y_2 = z_2$ , which is a contradiction. ■

When we say that a property holds up to rotation of the grid or mirroring it, we mean that we consider the same grid graph but the numbering of rows and columns is different. In particular, there are four choices for which corner is  $(1, 1)$ , and given that choice, there are two choices regarding which one of its two neighbors is denoted by  $(1, 2)$  (and which one is denoted by  $(2, 1)$ ). Fixing  $(1, 1)$  and  $(1, 2)$ , the numbering of the other vertices is unique. Thus, there are eight ways to number the vertices.

In the following analysis, we will assume that the top row and bottom row are two opposite sides that contain landmarks (otherwise, if one of these sides does not contain a landmark, we can rotate the grid). Obviously, a set may contain more than two vertices on two opposite sides. Given a set of vertices, out of pairs of vertices such that one is on the top row and the other is on the bottom row, we will always select two vertices such that the absolute value of the difference between the indices of their columns is minimal. By possibly mirroring the grid, given two such vertices, we will assume that the index of the column of the vertex of the bottom row is not smaller of the index of the column of the vertex of the top row. Thus, any subset of vertices which we will discuss has two vertices  $(1, z)$  and  $(m, z')$ , where  $z' \geq z$ . It is obviously possible that a landmark set will contain additional vertices of these two sides, and it may contain vertices of other sides, and internal vertices. By the choice of these two vertices from a given subset of vertices (such that  $|z' - z|$  is minimal), no vertex  $(1, z'')$  such that  $z < z'' < z'$  is an element of the set and no vertex  $(m, z'')$  such that  $z < z'' < z'$  is an element of the set. Moreover, if  $z \neq z'$ ,  $(1, z')$  and  $(m, z)$  are also not elements of this set. Since every landmark set has such a pair of landmarks on opposite sides (by Lemma 3), in what follows we only consider sets that contain this pair of vertices. We will assume that  $1 < z < z' \leq m$  or  $1 \leq z < z' < m$  holds (that is, at most one of  $(1, z)$  and  $(m, z')$  is a corner), as a minimal landmark set does not contain a pair of opposite corners. Moreover, in the case where  $z = z'$  and either  $z = 1$  or  $z = n$ , these two vertices are adjacent corners, and a minimal landmark set containing these two vertices has cardinality 2. Thus, in the analysis of landmark sets of cardinality at least 3, we assume that if  $z = z'$ , then  $1 < z < n$  holds.

**Lemma 8** *For a landmark set  $L$  such that  $(1, z), (m, z') \in L$ , where  $1 \leq z < z' \leq m$ ,  $L$*

has at least one vertex  $(a, b)$  such that either  $b \leq z$  and  $a > 1$  hold or  $b > z'$  and  $a = 1$  hold.

**Proof.** Consider a vertex  $(a, b)$  that separates  $(1, z + 1)$  and  $(2, z)$ . By Lemma 5, none of  $(1, z)$  and  $(m, z')$  separates  $(1, z + 1)$  and  $(2, z)$ . Moreover, as by the choice of  $(1, z)$  and  $(m, z')$ , no vertex of the form  $(1, z'')$  for  $z < z'' \leq z'$  is in  $L$ , if  $b \geq z + 1$  holds, then the stronger condition  $b \geq z' + 1$  holds as well. ■

**Lemma 9** Any set of the form  $\{(1, z), (m, z'), (1, z'')\}$  with  $1 \leq z < z' < z'' \leq n$  is a landmark set.

**Proof.** By Lemma 7, it is sufficient to prove that  $(1, z'')$  separates any pair of vertices on a joint diagonal, and they are vertices of the sub-grid of  $(1, z)$  and  $(m, z')$ . Let  $v_1 = (x_1, y_1)$  and  $v_2 = (x_2, y_2)$  be such that  $z \leq y_2 < y_1 \leq z'$ , and  $x_1 + y_1 = x_2 + y_2$  (so  $x_1 < x_2$ ). We have  $d(v_i, (1, z'')) = x_i - 1 + z'' - y_i$ . The two distances are distinct as  $(x_2 - 1 + z'' - y_2) - (x_1 - 1 + z'' - y_1) = x_2 - x_1 + y_1 - y_2 = (x_1 + y_1 - y_2) - x_1 + y_1 - y_2 = 2(y_1 - y_2) \neq 0$ . ■

By the last lemma and rotating the grid, any set of the form  $\{(1, z), (m, z'), (m, z'')\}$  with  $1 \leq z'' < z < z' \leq n$  is a landmark set as well.

**Lemma 10** A minimal landmark set  $L$  does not contain three vertices of one row or of one column.

**Proof.** We prove the claim for a column, the proof for a row is analogous. Consider three vertices  $(a_1, b)$ ,  $(a_2, b)$ , and  $(a_3, b)$ , where  $a_1 < a_2 < a_3$  and  $1 \leq b \leq n$ . We show that every pair of vertices separated by  $(a_2, b)$  is separated by at least one of the other two vertices. Assume that there exists a pair of vertices  $v_1 = (x_1, y_1)$  and  $v_2 = (x_2, y_2)$ , where  $v_1 \neq v_2$  and  $x_1 \leq x_2$ , that are not separated by  $(a_1, b)$  or  $(a_3, b)$ . Thus,  $|x_1 - a_1| + |y_1 - b| = |x_2 - a_1| + |y_2 - b|$  and  $|x_1 - a_3| + |y_1 - b| = |x_2 - a_3| + |y_2 - b|$ . Taking the difference between the inequalities, we get  $|x_1 - a_1| - |x_1 - a_3| = |x_2 - a_1| - |x_2 - a_3|$ .

If  $x_1 \leq a_1 < x_2 < a_3$ , we have  $|x_1 - a_1| - |x_1 - a_3| - |x_2 - a_1| + |x_2 - a_3| = a_1 - x_1 - a_3 + x_1 - x_2 + a_1 + a_3 - x_2 = 2(a_1 - x_2) < 0$ , a contradiction. If  $x_1 \leq a_1$  and  $a_3 \leq x_2$ , we have  $|x_1 - a_1| - |x_1 - a_3| - |x_2 - a_1| + |x_2 - a_3| = a_1 - x_1 - a_3 + x_1 - x_2 + a_1 + x_2 - a_3 = 2(a_1 - a_3) < 0$ , a contradiction as well. Analogously, we can prove that the case  $a_1 < x_1 < a_3$  and  $x_2 \geq a_3$  leads to a contradiction. If  $a_1 < x_1 < x_2 < a_3$ , then  $|x_1 - a_1| - |x_1 - a_3| - |x_2 - a_1| + |x_2 - a_3| = x_1 - a_1 - a_3 + x_1 - x_2 + a_1 + a_3 - x_2 = 2(x_1 - x_2) < 0$ , a contradiction.

Thus, one of  $x_1, x_2 \leq a_1$ ,  $a_1 < x_1 = x_2 < a_3$ , or  $x_1, x_2 \geq a_3$  holds. We show that  $d(v_1, (a_2, b)) = d(v_2, (a_2, b))$ , that is,  $|x_1 - a_2| + |y_1 - b| = |x_2 - a_2| + |y_2 - b|$ . To show this, it is sufficient to show that  $|x_1 - a_1| - |x_1 - a_2| = |x_2 - a_1| - |x_2 - a_2|$  holds. The equality obviously holds if  $x_1 = x_2$ . If  $x_1, x_2 \leq a_1$ , then  $|x_1 - a_1| - |x_1 - a_2| - |x_2 -$

$a_1| + |x_2 - a_2| = a_1 - x_1 - a_2 + x_1 - a_1 + x_2 + a_2 - x_2 = 0$ , and if  $x_1, x_2 \geq a_3$ , then  $|x_1 - a_1| - |x_1 - a_2| - |x_2 - a_1| + |x_2 - a_2| = x_1 - a_1 - x_1 + a_2 - x_2 + a_1 + x_2 - a_2 = 0$ . ■

**Lemma 11** *Consider a set of the form  $Y = \{(1, z), (m, z), (a, b)\}$ , such that  $1 \leq z \leq n$ . This set is a minimal landmark set if and only if  $b \neq z$  and  $z \neq 1, n$ .*

**Proof.** If  $z = 1$  or  $z = n$ , then  $\{(1, z), (m, z)\}$  is a landmark set, and therefore  $Y$  is not a minimal landmark set. Otherwise, assume  $b = z$ . Consider the vertices  $(1, z - 1)$  and  $(1, z + 1)$ . For any  $1 \leq r \leq n$ , We have  $d((1, z - 1), (r, z)) = r$  and  $d((1, z + 1), (r, z)) = r$ . Thus, if  $b = z$ , these two vertices do not have a separating vertex in the set  $Y$ .

We show that in the remaining cases  $Y$  is indeed a minimal landmark set. We assume  $b \neq z$  and  $1 < z < n$ . Since none of  $(1, z)$  and  $(m, z)$  is a corner, no proper subset of  $Y$  is a landmark set of cardinality 2. It is left to show that any pair of vertices is separated by a vertex of  $Y$ . Consider two vertices  $v_1 = (x_1, y_1)$  and  $v_2 = (x_2, y_2)$ , where  $y_1 \leq y_2$ . Assume that  $d(v_1, (1, z)) = d(v_2, (1, z))$  and  $d(v_1, (m, z)) = d(v_2, (m, z))$  hold. We will show that  $d(v_1, (a, b)) \neq d(v_2, (a, b))$ .

We find  $x_1 - 1 + |y_1 - z| = x_2 - 1 + |y_2 - z|$  and  $m - x_1 + |y_1 - z| = m - x_2 + |y_2 - z|$ . Taking the difference between the last two equalities we get  $x_1 = x_2$ . Moreover, if  $y_1, y_2 \leq z$  or  $y_1, y_2 \geq z$ , we also get  $y_1 = y_2$ . Thus, assume  $y_1 < z < y_2$ . We get  $y_2 - z = z - y_1$ , or equivalently,  $y_1 + y_2 = 2z$ . Without loss of generality assume  $b > z$  (the case  $b < z$  is analogous). We have  $d(v_1, (a, b)) = |x_1 - a| + b - y_1$  and  $d(v_2, (a, b)) = |x_2 - a| + |b - y_2|$ . Since  $x_1 = x_2$ , it is sufficient to prove  $|b - y_2| < b - y_1$ . If  $b \geq y_2$ , we have  $|b - y_2| - (b - y_1) = y_1 - y_2 < 0$ . Otherwise,  $|b - y_2| - (b - y_1) = y_1 + y_2 - 2b = 2(z - b) < 0$ . ■

As mentioned above, the following was proved in [1].

**Proposition 12** *Any minimal landmark set consisting of exactly three vertices has one of the following forms (up to rotating the grid or mirroring the grid).*

- $L = \{(1, z), (m, z'), (1, z_1)\}$ , where  $1 < z < z' < z_1 \leq m$  or  $1 \leq z < z' < z_1 < m$  (that is, at most one of  $(1, z)$  and  $(m, z')$  is a corner).
- $L = \{(1, z), (m, z'), (m, z_2)\}$ , where  $1 \leq z_2 < z < z' \leq m$  or  $1 \leq z < z' < z'' < m$ .
- $L = \{(1, z), (m, z), (y, z_3)\}$ , where  $1 < z < m$  and  $z_3 \neq z$ .

**Proof.** Consider a minimal landmark set  $L$  of cardinality 3. By our assumption, and landmark set contains  $(1, z)$  and  $(m, z')$ , and we analyze the options for the third vertex of the landmark set. If  $z = z'$ , by Lemma 11 the third vertex can be any vertex whose second component is not  $z$ , and the landmark set is of the third type.

Otherwise, by Lemma 8,  $L$  contains a vertex  $(a, b)$  where either  $a = 1$  and  $b > z'$  hold or  $a > 1$  and  $b \leq z$  hold. Since  $|L| = 3$ , this is the third vertex of  $L$ .

In the first case let  $z_1 = b$ . It does not hold that both  $z = 1$  and  $z_1 = m$ , as in this case  $\{(1, z), (1, z_1)\}$  is a landmark set, so the set  $L$  would not be minimal. The resulting form of  $L$  is of the first kind.

Otherwise, let  $b \leq z$ . Since the landmark set only has one additional vertex (except for  $(1, z)$  and  $(m, z')$ ), by applying the same property of Lemma 5 and rotating the grid, we find that if  $b \leq z'$ , then  $a = m$ , and the structure of the landmark set is of the second kind (and we let  $y = a$  and  $z_3 = b$ ). ■

In the case of minimal landmark sets with at least four vertices, we will assume  $z < z'$  due to the following. Consider a minimal landmark set (which has the elements  $(1, z)$  and  $(m, z')$ ). If  $z = z'$ , by Lemma 10, the landmark set has no other vertex of the same column. Assume that it has at least two additional vertices. Then, by Lemma 11, one vertex can be removed, such that the remaining set is a landmark set.

In order to define an algorithm for finding a minimum weight landmark set among minimal landmark sets of cardinality at least 4, we define a concept called *zigzag* sequence. This is a sequence of an even number (at least four) of vertices,  $q_1, q_2, \dots, q_{2k}$  for  $k \geq 2$ , where  $q_i = (s_i, d_i)$  satisfies the following properties. First,  $s_1 = 1$  and  $s_{2k} = m$  (and it will follow from the definition that  $d_1 < d_{2k}$ ). For even values of  $i$  ( $i = 2, 4, \dots, 2k$ ),  $d_i = d_{i-1}$  and  $s_i > s_{i-1}$  hold, and for odd values of  $i$  ( $i = 3, 5, \dots, 2k - 1$ ),  $s_i = s_{i-1}$  and  $d_i > d_{i-1}$  hold. That is, a zigzag sequence starts in the first row, in even steps the next vertex is below the previous vertex (in the same column), and in odd steps, the next vertex is to the right of the previous vertex (and in the same row). The last vertex is in the last row.

Given a zigzag sequence  $q_1, q_2, \dots, q_{2k}$ , we say that a sequence  $t_1, t_2, \dots, t_{2k}$  where  $t_i = (b_i, c_i)$  corresponds to this zigzag sequence (or it is a corresponding sequence) if  $t_1 = q_1$ , for even values of  $i$ ,  $b_i = s_i$  and  $r_i \leq d_i$ , and for odd values of  $i$  ( $i > 1$ ),  $r_i = d_i$  and  $b_i \leq s_i$ . Additionally,  $r_{2k} > c_1$ . That is, the first vertex is the same in both sequences. In even steps, the vertex of the corresponding sequence is to the left of the vertex of the zigzag sequence (in the same row, and they can possibly be equal), and in odd steps, the vertex of the corresponding sequence is above the vertex of the zigzag sequence (in the same column, and they can possibly be equal). The last vertex is in the last row, and its column must be larger of that of the first vertex.

A sequence that corresponds to a zigzag sequence  $S$  is called a *perfect* sequence (for this zigzag sequence) if it is the minimum cost sequence that corresponds to  $S$ . Since the condition for every  $i$  such that  $1 \leq i \leq 2k$  where  $2k$  is the length of  $S$  (the condition on which vertex can be the  $i$ th vertex of the corresponding sequence) is independent of other values of  $i$ . To obtain a perfect sequence that corresponds to  $S$ , it is required to select for

each  $i$  a vertex of minimum cost that satisfies the condition of a corresponding sequence. That is, for  $i = 1$  there is a unique vertex that can be the first vertex of the corresponding sequence, for an even step, a minimum cost vertex whose row is the same as the  $i$ th vertex of the zigzag sequence and its column is no larger than the column of the  $i$ th vertex of the zigzag sequence, for an odd step, a minimum cost vertex whose column is the same as the  $i$ th vertex of the zigzag sequence and its row is no larger than the row of the  $i$ th vertex of the zigzag sequence, and if  $i = 2k$ , the last vertex of the corresponding sequence has also a restriction on its column, that it is larger than the column of the first vertex of the zigzag sequence (and the corresponding sequence). Note that the conditions on the vertices of the corresponding sequence are independent of each other, and each of the  $2k$  vertices has a separate condition.

We note that while a sequence corresponding to a zigzag sequence defines its zigzag sequence in a unique way given a specific orientation of the grid, if we rotate the grid (by 180 degrees), and use the same sequence, the zigzag sequence may be different.

The following theorem connects zigzag sequence and landmark sets. Figure 2 illustrates this idea.

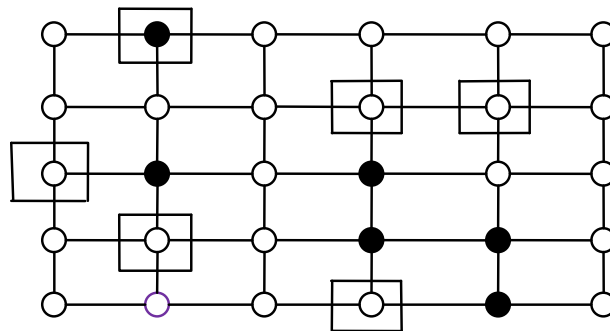

● — vertices of zigzag sequence

□ — vertices of landmark set

Figure 2: A zigzag sequence and a corresponding sequence (which is a landmark set). Notice that the vertex on row 1 is a common vertex of the two sequences.

**Theorem 13** *Every sequence that corresponds to some zigzag sequence is a landmark set. The vertices of every landmark set that has cardinality at least 4, and it is both a minimal landmark set and a minimum landmark set, can be ordered to form a perfect sequence for some zigzag sequence.*

**Proof.** We start with the first property, that is, we show that a sequence corresponding to a zigzag sequence is a landmark set. A sequence  $t_1, \dots, t_{2k}$  that corresponds to a zigzag sequence  $q_1, q_2, \dots, q_{2k}$  (where  $t_i = (b_i, c_i)$  and  $q_i = (s_i, d_i)$ ) satisfies  $t_1 = q_1 = (1, d_1)$ ,  $r_{2k} > c_1 = d_1$ , and  $b_{2k} = s_{2k} = m$ . Thus, by Lemma 7, it is sufficient to consider a pair of vertices of the sub-grid of  $t_1$  and  $t_{2k}$  that are on a joint diagonal. Since this sub-grid is contained in the sub-grid of  $q_1$  and  $(m, n)$ , we will prove the condition on separation of pairs of vertices of a sub-grid that are joint diagonals for the sub-grid of  $q_1 = t_1$  and  $(m, n)$ . We will show the following by induction. The vertices of the prefix  $t_1, \dots, t_i$  separate any pair of vertices of the sub-grid of  $q_1$  and  $(m, n)$  that are on a joint diagonal, possibly excluding pairs of vertices of the sub-grid of the vertices  $q_i$  and  $(m, n)$  that are on a joint diagonal. Since the sub-grid of  $q_{2k} = (m, d_{2k})$  and  $(m, n)$  has no such pairs (every diagonal of has at most one vertex of this sub-grid), the claim will follow. The base of the induction is trivial (as the claim is empty for this case). Assume that the requirements (which we are proving by induction) hold for a given value  $i$ , where  $i < 2k$ . The vertex  $t_{i+1}$  satisfies the conditions of Lemma 6 with respect to the sub-grid of  $q_i$  and  $(m, n)$ . Thus, the induction step follows from Lemma 6.

Next, we consider the second property. We will prove that any minimal landmark set contains a subset, such that this subset can be sorted into a sequence corresponding to some zigzag sequence. Since the set of elements of a sequence corresponding to a zigzag sequence was proved to be a landmark set, this shows that the selected subset cannot be a proper subset of the landmark set (as we are already considering a minimal landmark set). Thus, this will prove that any minimal landmark set can be sorted to form a sequence that corresponds to a zigzag sequence. It is also required to show that if the landmark set is not only a minimal landmark set but it is also a minimum landmark set, then its sorted sequence is a perfect sequence that corresponds to the zigzag sequence. Consider a minimal landmark set that its sorted sequence is not a perfect sequence for the zigzag sequence. As it is not a perfect sequence for the zigzag sequence, at least one landmark can be replaced such that the resulting sequence still corresponds to the same zigzag sequence but it has a smaller cost. This is possible as the vertices of the corresponding sequence can be selected independently of each other. Since a landmark set of a smaller cost exists, we find that the considered landmark set is not a minimum landmark set. Therefore, to complete the proof of the second property, it remains to show how a subset of any minimal landmark set of cardinality at least 4 can be selected and ordered such that a zigzag sequence can be defined for it (where the subset of the minimal landmark set will correspond to this zigzag sequence). This will hold in particular for a minimal landmark set that is also minimum, in which case the corresponding sequence will be perfect. We will use the notation as in the definition of a zigzag sequence and a corresponding sequence.

Recall that we assume that  $(1, z)$  and  $(m, z')$  belong to the landmark set, such that  $z < z'$ , and no vertex  $(1, \tilde{z})$  with  $z < \tilde{z} \leq z'$  belongs to the set, and no vertex  $(m, \hat{z})$  with  $z \leq \hat{z} < z'$  belongs to the set. We define the zigzag sequence and its corresponding sequence inductively, such that the last vertex of the corresponding sequence is  $(m, z')$  (that is, the selection process of vertices from the landmark set ends when this vertex is selected).

Let  $q_1 = t_1 = (1, z)$ , that is, the first vertex of both sequences is fixed. In an odd step of index  $i \geq 3$ , given  $q_{i-1} = (s_{i-1}, d_{i-1})$ , we will select a vertex of the landmark set that was not selected yet to be  $t_i$ , such that the the first component of the vertex is no larger than  $s_{i-1}$ , and its second component is above  $d_{i-1}$ . In an odd step of index  $i$ , given  $q_{i-1} = (s_{i-1}, d_{i-1})$ , we will select a vertex of the landmark set that was not selected yet to be  $t_i$ , such that the the first component of the vertex is no larger than  $s_{i-1}$ , and its second component is above  $d_{i-1}$ . In a case of ties, we will select a vertex whose second component is maximum. That is, we select a vertex  $t_i$  that is above the sub-grid of the vertices  $(s_{i-1}, d_{i-1})$  and  $(m, n)$ . In this case,  $q_i = (s_{i-1}, c_i)$ . In an even step of index  $i \geq 2$ , given  $q_{i-1} = (s_{i-1}, d_{i-1})$ , we will select a vertex of the landmark set that was not selected yet to be  $t_i$ , such that the the second component of the vertex is no larger than  $d_{i-1}$ , and its first component is above  $s_{i-1}$ . In a case of ties, we will select a vertex whose first component is maximum. Moreover, if  $(m, z')$  is a valid candidate,  $t_i$  is defined to be  $(m, z')$  (this does not contradict the tie breaking rule). If  $q_i$  is defined such that  $s_i = m$ , the process is terminated. That is, we select a vertex that is to the left of the sub-grid of the vertices  $(s_{i-1}, d_{i-1})$  and  $(m, n)$ . In this case,  $q_i = (b_i, d_{i-1})$ . We will show by induction that this is always possible, that is, such a vertex always exist, and that the process terminates. If  $t_i$  and  $q_i$  are defined in every step, the process terminates, and  $t_{2k} = (m, z')$ , the sequences satisfy the requirements of a zigzag sequence and its corresponding sequence. We will prove a number of properties by induction, and it will follow from the proof that the sequences were defined properly.

More precisely, we prove by induction that the following properties hold after defining  $t_i$  and  $q_i$ .

1. The vertices  $t_i$  and  $q_i$  are well-defined.
2. For any  $i'$  such that  $1 \leq i' \leq i$ , it holds that  $b_{i'} \leq s_i$  and  $c_{i'} \leq d_i$ .
3. If  $i$  is even, then the landmark set has no vertex  $(x, y)$  such that  $x > s_i$  and  $y \leq d_i$ .
4. If  $i$  is odd, then the landmark set has no vertex  $(x, y)$  such that  $x \leq s_i$  and  $y > d_i$ .
5. If  $i$  is even then either  $s_i \leq m - 1$  or  $t_i = (m, z')$ . Moreover, if  $s_i \leq m - 1$ , then  $d_i < z'$ .

6. If  $i$  is odd, then  $s_i \leq m - 1$ .

Consider the case  $i = 1$ . The first property holds as we defined  $t_1$  and  $q_1$ . The second property holds as the only relevant value of  $i'$  is 1, and by  $t_1 = q_1$ . Since  $i$  is odd, we prove the fourth and sixth properties. The sixth property holds as  $s_1 = 1$ . Recall that the landmark set is minimal and its cardinality is at least 4. To prove the fourth property, we show that the landmark set has no vertex  $(1, \bar{z})$ , where  $z < \bar{z} \leq n$ . By the choice of  $(1, z)$  and  $(m, z')$ , the landmark set has no vertex  $(1, \bar{z})$ , where  $z < \bar{z} \leq z'$ . If the landmark set has a vertex  $(1, \bar{z})$ , where  $z' < \bar{z} \leq n$ , we can prove that the landmark set is not minimal. If  $z = 1$  and  $\bar{z} = n$  both hold, then  $\{(1, z), (m, z')\}$  is a set of two adjacent corners and thus it is a landmark set. Otherwise,  $\{(1, z), (m, z'), (1, \bar{z})\}$  is a landmark set.

Next, consider an even value of  $i$ . By the induction hypothesis (the sixth property), since the process did not terminate, no vertex of the landmark set of the last row was selected and in particular,  $s_{i-1} \leq m - 1$ . If  $d_{i-1} = n$ , then the vertex  $(m, z')$  is defined to be  $t_i$  as  $m > s_{i-1}$  and  $z' \leq n$ . The vertex  $q_i$  is defined as  $(m, n)$ . The first property is satisfied, and all remaining properties hold trivially. Otherwise, assume  $d_{i-1} \leq n - 1$ . By the induction hypothesis, all landmarks  $t_1, t_2, \dots, t_{i-1}$  have first components in  $[1, s_{i-1}]$  and second components in  $[1, d_{i-1}]$ . Thus, their shortest paths to the vertices  $(s_{i-1} + 1, d_{i-1})$  and  $(s_{i-1}, d_{i-1} + 1)$  traverse  $(s_{i-1}, d_{i-1})$ , and none of  $t_1, t_2, \dots, t_{i-1}$  separates them. The landmark set has at least one vertex separating them. Moreover, any vertex  $(x, y)$  where  $x \geq s_{i-1} + 1$  and  $y \geq d_{i-1} + 1$  has shortest paths to these two vertices traversing  $(s_{i-1} + 1, d_{i-1} + 1)$ . By the induction hypothesis, the landmark set has no vertex  $(x, y)$  where  $x \leq s_{i-1}$  and  $y \geq d_{i-1} + 1$ , and therefore it has at least one vertex  $(x, y)$  where  $x \geq s_{i-1} + 1$  and  $y \leq d_{i-1}$ . Such a vertex is selected as  $t_i$ , and  $q_i$  is defined such that the requirements of a zigzag sequence and its corresponding sequence are satisfied to be  $q_i = (b_i, d_{i-1})$ . Since  $s_i > s_{i-1}$  and  $d_i = d_{i-1}$ ,  $b_{i'} \leq s_i$  and  $c_{i'} \leq d_i$  holds for any  $i' < i$  using the induction hypothesis. Moreover,  $b_i = s_i$  and  $c_i \leq d_{i-1} = d_i$  holds by definition. Thus, the second property holds. If  $s_i = b_i = m$ , then the third property holds trivially. Otherwise, since  $t_i$  was selected to have a maximum first component, and therefore is a vertex with a first component above  $s_i$  and second component of at most  $d_{i-1} = d_i$  would have been chosen instead  $t_i$ , if it existed. If  $d_{i-1} \geq z'$ , then  $(m, z')$  is selected as  $t_i$ , since  $m \geq s_{i-1} + 1$  and  $z' \leq d_{i-1}$ . If indeed  $(m, z')$  is selected, we have  $q_i = (m, d_{i-1})$ . In this last case the fifth property holds. Assume that  $s_i = b_i = m$  while  $c_i \neq z'$ . This means that  $c_i < z'$  and  $d_{i-1} < z'$ , as otherwise  $(m, z')$  could be selected. Since the landmark set has no vertex  $(m, \bar{z})$  with  $z \leq \bar{z} < z'$ , we have  $t_i = (m, c_i)$ , where  $c_i < z$ . However, in this case  $\{(1, z), (m, z'), (m, \bar{z})\}$  is a landmark set, contradicting the assumption that the landmark set is minimal and its cardinality is at least 4. Thus, we are left with the case  $s_i = b_i \leq m - 1$ . If  $d_{i-1} \geq z'$ , then  $(m, z')$  would be a candidate for selection as  $t_i$ , and



thus  $d_{i-1} < z'$ .

Finally, consider an odd value of  $i$ . By the induction hypothesis,  $s_{i-1} \leq m - 1$  and  $d_{i-1} \leq z' - 1 \leq n - 1$ . The property that  $t_i$  and  $q_i$  are well-defined are proved analogously to the case of even  $i$ , as the landmark set has a vertex separating  $(s_{i-1} + 1, d_{i-1})$  and  $(s_{i-1}, d_{i-1} + 1)$ . The second property holds similarly to the case of even  $i$ , the fourth property again holds due to the selection rule of a vertex with a maximum second component, and the sixth property holds as  $s_i = s_{i-1} \leq m - 1$ . ■

We show how the known result for the cardinality of a minimal landmark set [1], where this cardinality is  $\min\{2n - 2, 2m - 2\}$  for  $\min\{m, n\} \geq 3$ , follows from the relation to zigzag sequences. In a zigzag sequence, any row has at most two vertices, while the first row and the last row have one vertex each. By definition, a zigzag sequence has at most  $2m - 2$  vertices. This implies an upper bound of  $2m - 2$  on the cardinality of a zigzag sequence, since the number of vertices in the zigzag sequence and the corresponding landmark set are equal, and we can consider cardinalities of landmark sets. If  $m \leq n$ , we are done. Otherwise, note that a zigzag sequence has at most two vertices in each column. If it has no vertices of the last column, it has at most  $2n - 2$  vertices. Otherwise, by the definition of a zigzag sequence (where is particular, it has an even number of vertices), the sequences has exactly two vertices in each column, including the first column and the last column. Since it has a vertex of the last row and a vertex of the first row, it has two opposite corners, contradicting Lemma 2. Since zigzag sequences have even cardinalities, we find that minimal landmark sets also have even cardinalities, except for those that have cardinality 3.

The action of the algorithm starts with computing the following values, which are prefix, suffix, and range minima of rows and columns of the grid. For  $1 \leq i \leq m$  and  $1 \leq j \leq n$ , let

$$\begin{aligned} Rpref_i^j &= \min_{1 \leq k \leq j} c_{i,k} \quad , \quad Rsuff_i^j = \min_{j \leq k \leq n} c_{i,k} \quad , \\ Cpref_j^i &= \min_{1 \leq k \leq i} c_{k,j} \quad , \quad Csuff_j^i = \min_{i \leq k \leq n} c_{k,j} \quad . \end{aligned}$$

These are the prefix minima of rows, suffix minima of rows, prefix minima of columns, and suffix minima of columns, respectively. All the  $Rpref_{i,j}$  values for a given value of  $i$  can be computed together in time  $O(n)$  by the following simple dynamic programming formulation:  $Rpref_i^1 = c_{i,1}$ , and for  $j \geq 2$ ,  $Rpref_i^j = \min\{c_{i,j}, RL_i^{j-1}\}$ . Similarly, all  $2m + 2n$  values can be computed in time  $O(m + n)$ . For the side row and columns we also compute range minima. For  $i = 1, m$  and any  $1 \leq j \leq \ell \leq n$ , let  $Rrange_j^{j,\ell} = \min_{j \leq k \leq \ell} c_{i,k}$ , and for  $j = 1, n$  and any  $1 \leq i \leq t \leq m$ , let  $Crange_j^{i,t} = \min_{i \leq k \leq t} c_{k,j}$ . For a given value of  $j$ , all values  $Rrange_1^{j,\ell}$  and  $Rrange_m^{j,\ell}$  can be computed in time  $O(n)$ , while  $Crange_1^{i,t}$  and  $Crange_n^{i,t}$  can be computed in time  $O(m)$  for a given value of  $i$ . Thus, the time of computing

all the values  $Rrange_1^{j,\ell}$ ,  $Rrange_m^{j,\ell}$ ,  $Crangle_1^{i,t}$ , and  $Crangle_n^{i,t}$  is  $\Theta(m^2 + n^2) = O(|V|^2)$ . It is possible to keep also the identities of the vertices of minimum costs using the same running time.

Our algorithm computes candidate landmark sets and selects a set of minimum weight among these sets. There are four landmark sets of cardinality 2, and they can be enumerated in time  $O(1)$ . There are two types of landmark sets of cardinality three. The first kind is where two landmarks are on opposite sides, sharing the same row or column (depending on which sides these are), and a third landmark can be any vertex not on the same two or column as the two other landmarks. There are  $O(m)$  candidate pairs on rows and  $O(n)$  pairs on columns. Using the values defined above (the values  $Rpref_i^n = Rsuffix_i^1$  and  $Cpref_j^m = Csuffix_j^1$ ), we can find a vertex of minimum cost in the grid  $(x_m, y_m)$ , another vertex that has minimum cost out of vertices on other columns (not on column  $y_m$ ), and another vertex that has minimum cost out of vertices on other rows (not on row  $x_m$ ). The last two vertices are distinct from  $(x_m, y_m)$ , but both of them can possibly be the same vertex. These two or three vertices can be computed in time  $O(m + n)$ . For each pair on a column, and given the (at most) three vertices defined here, we find a minimum cost vertex that is not on a certain column or not on a certain row in time  $O(1)$  for each candidate pair. The second kind of landmark sets with cardinality three consists of two vertices on one side, and one vertex on the opposite side, on a column that is strictly between the columns of the first two vertices. For every vertex  $v$  on a side, it is possible to use the values  $Rrange_1^{j,\ell}$ ,  $Rrange_m^{j,\ell}$ ,  $Crangle_1^{i,t}$ , and  $Crangle_n^{i,t}$  to find two vertices of minimum cost on the opposite side, such that the vertex is between them. For  $v = (1, z)$ , such that  $1 < z < n$ , the costs of the required two vertices are  $Rrange_m^{1,z-1}$  and  $Rrange_m^{z+1,n}$ . For  $v = (m, z)$ , such that  $1 < z < n$ , the costs of the required two vertices are  $Rrange_1^{1,z-1}$  and  $Rrange_1^{z+1,n}$ . For  $v = (q, 1)$ , such that  $1 < q < m$ , the costs of the required two vertices are  $Crangle_n^{1,q-1}$  and  $Crangle_n^{q+1,m}$ . For  $v = (q, n)$ , such that  $1 < q < m$ , the costs of the required two vertices are  $Crangle_1^{1,q-1}$  and  $Crangle_1^{q+1,m}$ . Thus, a landmark set of minimum weight of this form can be found in time  $O(m + n)$ , as the candidates for the vertex  $v$  are all side vertices (excluding corners).

Finally, in order to find a minimum weight landmark set out of landmark sets of cardinality at least 4, we define a dynamic programming algorithm. We present the algorithm for the case where the landmark set corresponds to a zigzag sequence as defined above. In order to consider all relevant subsets, the algorithm is applied eight times, such that the grid is rotated and mirrored in all possible directions. We define the following functions for any vertex  $v = (1, z)$  with  $1 \leq z \leq n - 1$ . For any vertex  $u = (a, b)$ , let  $F_v^o(a, b)$  denote the minimum weight of an odd length prefix of a sequence that corresponds to a prefix of a zigzag sequence whose first vertex is  $v$  and the last vertex is  $u$ , and let  $F_v^e(a, b)$

denote the minimum weight of an even length prefix of a sequence that corresponds to a prefix of a zigzag sequence whose first vertex is  $v$  and the last vertex is  $u$ . We also let  $G_v^o(a, b) = \min_{1 \leq i \leq a} F_v^o(i, b)$  and  $G_v^e(a, b) = \min_{1 \leq j \leq b} F_v^e(a, j)$ .

We have

$$G_v^o(1, z) = F_v^o(1, z) = c(z) \quad \text{and} \quad G_v^e(1, z) = F_v^e(1, z) = \infty .$$

Moreover, for any  $u = (1, z')$  such that  $z' \neq z$ ,

$$G_v^e(1, z') = F_v^e(1, z') = F_v^o(1, z') = G_v^o(1, z') = \infty .$$

For  $u = (r', z')$ , where  $1 < r' < m$ , we let

$$F_v^o(r', z') = G_v^e(r', z' - 1) + Cpref_{r'}^{z'}, \quad G_v^o(r', z') = \min\{F_v^o(r', z'), G_v^o(r' - 1, z')\} ,$$

$$F_v^e(r', z') = G_v^o(r' - 1, z') + Rpref_{r'}^{z'}, \quad \text{and} \quad G_v^e(r', z') = \min\{F_v^e(r', z'), G_v^e(r', z' - 1)\} .$$

Finally, for  $u = (m, z')$ , we let  $G_v^o(m, z') = F_v^o(m, z') = \infty$ ,  $G_v^e(m, z') = F_v^e(m, z') = \infty$ , if  $z' \leq z$ , and if  $z' > z$ , we let

$$F_v^e(m, z') = G_v^o(m - 1, z') + Rrange_m^{z+1, z'} ,$$

and  $G_v^e(m, z') = \min\{F_v^e(m, z'), G_v^e(m, z' - 1)\}$ . The minimum cost of a sequence corresponding to a zigzag sequence starting at  $v$  is  $G_v^e(m, n)$ , and the set of vertices can be found via traceback. The running time for a fixed vertex  $v$  is  $O(|V|)$ .

The total running time of the algorithm is  $\Theta((m + n)|V|) = O(|V|^2)$ .

## References

- [1] P. Andersen, C. Grigorious, and M. Miller. Minimum weight resolving sets of grid graphs. arXiv:1409.4510.
- [2] L. Babai. On the order of uniprimitive permutation groups. *Annals of Mathematics*, 113(3):553–568, 1981.
- [3] Z. Beerliova, F. Eberhard, T. Erlebach, A. Hall, M. Hoffmann, M. Mihalák, and L. S. Ram. Network discovery and verification. *IEEE Journal on Selected Areas in Communications*, 24(12):2168–2181, 2006.
- [4] J. Cáceres, M. C. Hernando, M. Mora, I. M. Pelayo, M. L. Puertas, C. Seara, and D. R. Wood. On the metric dimension of cartesian products of graphs. *SIAM Journal on Discrete Mathematics*, 21(2):423–441, 2007.

- [5] G. Chartrand, L. Eroh, M. A. Johnson, and O. R. Oellermann. Resolvability in graphs and the metric dimension of a graph. *Discrete Applied Mathematics*, 105(1-3):99–113, 2000.
- [6] G. Chartrand and P. Zhang. The theory and applications of resolvability in graphs: A survey. *Congressus Numerantium*, 160:47–68, 2003.
- [7] V. Chvátal. Mastermind. *Combinatorica*, 3(3):325–329, 1983.
- [8] J. Díaz, O. Pottonen, M. J. Serna, and E. J. van Leeuwen. On the complexity of metric dimension. In L. Epstein and P. Ferragina, editors, *ESA*, volume 7501 of *Lecture Notes in Computer Science*, pages 419–430. Springer, 2012.
- [9] L. Epstein, A. Levin, and G. J. Woeginger. The (weighted) metric dimension of graphs: Hard and easy cases. *Algorithmica*, 72(4):1130–1171, 2015.
- [10] F. Harary and R. Melter. The metric dimension of a graph. *Ars Combinatoria*, 2:191–195, 1976.
- [11] M. Hauptmann, R. Schmied, and C. Viehmann. Approximation complexity of metric dimension problem. *Journal of Discrete Algorithms*, 14:214–222, 2012.
- [12] S. Khuller, B. Raghavachari, and A. Rosenfeld. Landmarks in graphs. *Discrete Applied Mathematics*, 70(3):217–229, 1996.
- [13] R. A. Melter and I. Tomescu. Metric bases in digital geometry. *Computer Vision, Graphics, and Image Processing*, 25:113–121, 1984.
- [14] A. Sebö and E. Tannier. On metric generators of graphs. *Mathematics of Operations Research*, 29(2):383–393, 2004.
- [15] B. Shanmukha, B. Sooryanarayana, and K. S. Harinath. Metric dimension of wheels. *Far East Journal of Applied Mathematics*, 8(3):217–229, 2002.
- [16] P. J. Slater. Leaves of trees. *Congressus Numerantium*, 14:549–559, 1975.