

# Two-Loop QCD Correction to massive spin-2 resonance $\rightarrow$ 3 gluons

---

Taushif Ahmed,<sup>a</sup> Maguni Mahakhud,<sup>a</sup> Prakash Mathews,<sup>b</sup> Narayan Rana<sup>a</sup> and V. Ravindran<sup>c</sup>

<sup>a</sup>*Harish-Chandra Research Institute,  
Chhatnag Road, Jhansi, Allahabad 211 019, Uttar Pradesh, India*

<sup>b</sup>*Saha Institute of Nuclear Physics,  
1/AF Bidhan Nagar, Kolkata 700 064, India*

<sup>c</sup>*The Institute of Mathematical Sciences,  
C.I.T Campus, 4th Cross St, Tharamani, Chennai 600 113, Tamil Nadu, India*

*E-mail:* [taushif@hri.res.in](mailto:taushif@hri.res.in), [maguni@hri.res.in](mailto:maguni@hri.res.in),  
[prakash.mathews@saha.ac.in](mailto:prakash.mathews@saha.ac.in), [narayan@hri.res.in](mailto:narayan@hri.res.in), [ravindra@imsc.res.in](mailto:ravindra@imsc.res.in)

ABSTRACT: We present the  $\mathcal{O}(\alpha_s^3)$  virtual QCD corrections to the process  $h \rightarrow g+g+g$  due to interference of born and two-loop amplitudes, where  $h$  is a massive spin-2 particle and  $g$  is the gluon. We assume that the SM fields couple to  $h$  through the SM energy momentum tensor. Our result constitutes one of the ingredients to full NNLO QCD contribution to production of a massive spin-2 particle along with a jet in the scattering process at the LHC. In particular, this massive spin-2 could be a KK mode of a ADD graviton in large extra dimensional model or a RS KK mode in warped extra dimensional model or a generic massive spin-2. In addition, it provides an opportunity to study the ultraviolet and infrared structures of QCD amplitudes involving tensorial coupling resulting from energy momentum operator. Using dimensional regularization, we find that infrared poles of this amplitude are in agreement with the proposal by Catani confirming the factorization property of QCD amplitudes with tensorial insertion.

KEYWORDS: QCD, Spin-2 and NNLO calculation

---

## Contents

<b>1</b>	<b>Introduction</b>	<b>1</b>
<b>2</b>	<b>Theory</b>	<b>3</b>
2.1	The effective Lagrangian	3
2.2	Notation	4
2.3	Ultraviolet renormalization	4
2.4	Infrared factorization	5
<b>3</b>	<b>Calculation of two-loop amplitude</b>	<b>6</b>
3.1	Feynman diagrams and simplification	6
3.2	Reduction of tensor integrals	7
3.3	Master integrals	9
<b>4</b>	<b>Results</b>	<b>10</b>
<b>5</b>	<b>Conclusion</b>	<b>11</b>
<b>A</b>	<b>Harmonic polylogarithms</b>	<b>13</b>
<b>B</b>	<b>One-loop coefficients</b>	<b>14</b>
<b>C</b>	<b>Two-loop coefficients</b>	<b>15</b>

---

## 1 Introduction

Theoretical studies on production and decay of a spin  $J^P$  particle in the hadron colliders in the Standard Model (SM) and its extensions are underway due to a wealth of information available from ATLAS [1] and CMS [2] collaborations at the Large Hadron Collider (LHC). In particular, investigations involving particles with higher spin, namely  $J^P = 2^+$  bosons gained attention [3, 4] due to the discovery of a new boson at the LHC with a mass  $m \approx 125$  GeV as its spin is yet to be determined with no doubt. Searches of spin-2 particles earlier in Tevatron and recently in LHC were motivated due to their presence in theories with large extra dimensions, such as ADD [5] and warped extra dimensions such as RS [6] models. These beyond the SM (BSM) theories provide an alternate scenario to explain the hierarchy problem of the SM through the introduction of compact higher dimensions with factorisable (ADD) or non-factorisable (RS) geometries. The impact of these higher dimensions can be understood in four dimensional framework through the existence of a tower of massive spin-2 Kaluza-Klein (KK) gravitons. Their signatures at the colliders can provide valuable information on these models. For the production of scalar  $J^P = 0^+$

and vector  $J^P = 1^+$  particles in the SM and BSM, there are extensive studies available in literature. They include inclusive and semi-inclusive rates taking into account quantum chromodynamics (QCD) and electroweak (EW) radiative corrections to impressively high orders in perturbative expansion. Thanks to universal features of some of the perturbative corrections in QCD, one can safely use those computed in the SM for BSM processes. For spin-2 particles, searches in Drell-Yan (DY), di-photon and jet+missing energy at the LHC are already underway. Also the bounds on the scale of the new physics and the number of extra-dimensions are severely constrained from these searches. These studies use theoretical results computed in QCD at NLO level in perturbation theory. Such computations are inevitable due to various uncertainties resulting from renormalization and factorization scales as well as from the parton distribution functions. Needless to say that the corrections are also big giving large K-factors which are often sensitive to the observables and their physical scales. In ADD and RS models spin-2 KK gravitons contribute to physical processes through either exchange of virtual graviton state or production of a real graviton state. In the virtual mode, KK gravitons get exchanged between the SM particles and the summation over their high multiplicity leads to a compensation of small coupling strength. Hence, the cross section will be appreciable at collider energies, giving rise to non-resonant enhancement of the high invariant mass regions of a di-final state production [7–9] or final states involving more particles [10]. Next to leading order QCD corrections were computed for the di-final state processes in the ADD model *viz.*  $\ell^+\ell^-$  [11–13],  $\gamma\gamma$  [14, 15] and  $ZZ$  [16, 17] and  $W^+W^-$  [18, 19], in addition they have been extended to NLO+PS accuracy [20, 21]. On-shell spin-2 particle production results in missing energy signal. Again large multiplicity of final states enhances the observable effects. Productions of on-shell spin-2 gravitons in association with (a) jet [22], (b) photon [23] and (c) electroweak gauge boson [24] have been studied to NLO in QCD. Similar results taking into account NLO QCD effects for processes involving the resonant production of spin-2 graviton are available for di-lepton production [12, 13], di-photon production [15], di-neutral electroweak gauge boson production [17] and charged electroweak gauge boson production  $W^+W^-$  [19]. Since the NLO corrections and the associated scale uncertainties are not completely under control in most of the observable, an attempt [25] was undertaken to include soft and collinear contribution to NNLO accuracy for processes involving KK gravitons in both ADD and RS models. This was possible as the full two loop QCD matrix element of energy momentum tensor is now available [26]. The phenomenological results show significant reduction in dependence on renormalization and factorization scales and these results improve the stability of the perturbative predictions.

Observables with jet + missing energy are sensitive to new physics from many BSM scenarios. This missing energy could be due to a heavy resonance produced in the final state escaping the detector. The NLO QCD effects to this process in large extra dimensional model, namely ADD have been available for sometime and the importance of K-factor and scale uncertainties are documented in [22]. In this article, we compute  $\mathcal{O}(\alpha_s^3)$  virtual correction in massless QCD to the process  $h \rightarrow g + g + g$  due to interference of born and two-loop amplitudes, where  $h$  is a massive spin-2 particle. The full NNLO analysis also requires square of one loop amplitudes, real emission processes and appropriate mass

counter terms which we reserve for future work. We have assumed a minimal coupling between massive spin-2 field and the fields of the SM. Hence our results are applicable to scattering processes involving a massive spin-2 particle and three gluons such as a massive graviton production with a jet in ADD and RS models or production of a massive spin-2 Higgs like boson along with a jet after appropriate analytical continuation [27] of kinematical variables to the respective physical regions. Similar computations with massive spin-0 and spin-1 boson productions at two loop level in QCD exist in the literature for the processes  $Higgs \rightarrow g + g + g$  [28] and  $g + g \rightarrow V + jet, V = Z, \gamma$  [29] respectively.

Spin-2 field being a rank-2 tensor, we encounter for the first time the two loop amplitudes with higher tensorial integrals resulting from rank-2 derivative couplings of spin-2 fields with the SM ones. In addition, we encounter more than 2000 two loop Feynman amplitudes contributing due to the universal coupling of spin-2 field with all the SM particles. While these increase technical complexities at the intermediate stages of computation, the results confirm the universal infra-red structure of QCD amplitudes. In other words, we find that soft and collinear divergences not only factorise but also agree with the predictions from Catani's work [30] (see also [31]) on two loop QCD amplitudes for multi-leg processes. We also observe that there are no additional UV divergences as the interaction is through energy momentum tensor of the SM which is conserved. Hence, our present work is also useful to study the field theoretical structure of QCD amplitudes with tensor operator insertions, in particular with the energy momentum tensor of the SM.

In the next section, we describe the generic effective Lagrangian that describes coupling of spin-2 fields with those of the SM. Section 3 is devoted to the computational details. Section 4 and Appendix contain our final results. In section 5, we conclude with our findings.

## 2 Theory

### 2.1 The effective Lagrangian

We consider the SM with an additional spin-2 field  $h^{\mu\nu}$ . We assume that the spin-2 field couples minimally with the SM ones through the SM energy momentum tensor  $T_{\mu\nu}^{SM}$ . Since we are interested only in the QCD effects of the process under study, we restrict ourselves to the QCD part of  $T_{\mu\nu}^{SM}$  and hence the action reads [5, 6] as

$$\mathcal{S} = \mathcal{S}_{SM} + \mathcal{S}_h - \frac{\kappa}{2} \int d^4x T_{\mu\nu}^{QCD}(x) h^{\mu\nu}(x), \quad (2.1)$$

where  $\kappa$  is a dimensionful coupling and  $T_{\mu\nu}^{QCD}$  is the energy momentum tensor of QCD given by

$$\begin{aligned} T_{\mu\nu}^{QCD} = & -g_{\mu\nu} \mathcal{L}_{QCD} - F_{\mu\rho}^a F_{\nu}^{a\rho} - \frac{1}{\xi} g_{\mu\nu} \partial^\rho (A_\rho^a \partial^\sigma A_\sigma^a) + \frac{1}{\xi} (A_\nu^a \partial_\mu (\partial^\sigma A_\sigma^a) + A_\mu^a \partial_\nu (\partial^\sigma A_\sigma^a)) \\ & + \frac{i}{4} \left[ \bar{\psi} \gamma_\mu (\overrightarrow{\partial}_\nu - ig_s T^a A_\nu^a) \psi - \bar{\psi} (\overleftarrow{\partial}_\nu + ig_s T^a A_\nu^a) \gamma_\mu \psi + \bar{\psi} \gamma_\nu (\overrightarrow{\partial}_\mu - ig_s T^a A_\mu^a) \psi \right. \\ & \left. - \bar{\psi} (\overleftarrow{\partial}_\mu + ig_s T^a A_\mu^a) \gamma_\nu \psi \right] + \partial_\mu \bar{\omega}^a (\partial_\nu \omega^a - g_s f^{abc} A_\nu^c \omega^b) \end{aligned}$$

$$+\partial_\nu \bar{\omega}^a (\partial_\mu \omega^a - g_s f^{abc} A_\mu^c \omega^b). \quad (2.2)$$

$g_s$  is the strong coupling constant and  $\xi$  is the gauge fixing parameter. The  $T^a$  are generators and  $f^{abc}$  are the structure constants of  $SU(3)$ . Note that spin-2 fields couple to ghost fields ( $\omega^a$ ) [32] as well in order to cancel unphysical degrees of freedom of gluon fields ( $A_\mu^a$ ).

## 2.2 Notation

We consider the decay of a massive spin-2 field into three gluons

$$h(q) \rightarrow g(p_1) + g(p_2) + g(p_3). \quad (2.3)$$

The associated Mandelstam variables are defined as

$$s \equiv (p_1 + p_2)^2, \quad t \equiv (p_2 + p_3)^2, \quad u \equiv (p_1 + p_3)^2 \quad (2.4)$$

which satisfy

$$s + t + u = M_h^2 \equiv Q^2 \quad (2.5)$$

where  $M_h$  is the mass of the spin-2 field. We also define the following dimensionless invariants which appear in harmonic polylogarithms (HPL) [33] and 2dHPL [34, 35] as

$$x \equiv s/Q^2, \quad y \equiv u/Q^2, \quad z \equiv t/Q^2 \quad (2.6)$$

satisfying

$$x + y + z = 1. \quad (2.7)$$

## 2.3 Ultraviolet renormalization

We describe here the ultraviolet (UV) renormalization of the matrix elements of the decay of a spin-2 resonance with minimal coupling up to second order in QCD perturbation theory. We regularize the theory in  $d = 4 + \epsilon$  dimensions and the dimensionful strong coupling constant in  $d$  dimensions is made dimensionless one ( $\hat{g}_s$ ) by introducing the scale  $\mu_0$ . We expand the unrenormalized amplitude in powers of  $\hat{a}_s = \hat{g}_s^2/16\pi^2$  as

$$|\mathcal{M}\rangle = \left(\frac{\hat{a}_s}{\mu_0^\epsilon} S_\epsilon\right)^{\frac{1}{2}} |\hat{\mathcal{M}}^{(0)}\rangle + \left(\frac{\hat{a}_s}{\mu_0^\epsilon} S_\epsilon\right)^{\frac{3}{2}} |\hat{\mathcal{M}}^{(1)}\rangle + \left(\frac{\hat{a}_s}{\mu_0^\epsilon} S_\epsilon\right)^{\frac{5}{2}} |\hat{\mathcal{M}}^{(2)}\rangle + \mathcal{O}(\hat{a}_s^3), \quad (2.8)$$

where  $S_\epsilon = \exp[\frac{\epsilon}{2}(\gamma_E - \ln 4\pi)]$  with Euler constant  $\gamma_E = 0.5772\dots$ , results from loop integrals beyond leading order.  $|\hat{\mathcal{M}}^{(i)}\rangle$  is the unrenormalized color-space vector representing the  $i^{\text{th}}$  loop amplitude. In  $\overline{MS}$  scheme, the renormalized coupling constant  $a_s \equiv a_s(\mu_R^2)$  at renormalization scale  $\mu_R$  is related to unrenormalized coupling constant  $\hat{a}_s$  by

$$\begin{aligned} \frac{\hat{a}_s}{\mu_0^\epsilon} S_\epsilon &= \frac{a_s}{\mu_R^\epsilon} Z(\mu_R^2) \\ &= \frac{a_s}{\mu_R^\epsilon} \left[ 1 + a_s \frac{2\beta_0}{\epsilon} + a_s^2 \left( \frac{4\beta_0^2}{\epsilon^2} + \frac{\beta_1}{\epsilon} \right) + \mathcal{O}(a_s^3) \right], \end{aligned} \quad (2.9)$$

where

$$\beta_0 = \left( \frac{11}{3}C_A - \frac{4}{3}T_F n_f \right), \quad \beta_1 = \left( \frac{34}{3}C_A^2 - \frac{20}{3}C_A T_F n_f - 4C_F T_F n_f \right) \quad (2.10)$$

with  $C_A = N$ ,  $C_F = (N^2 - 1)/2N$ ,  $T_F = 1/2$  and  $n_f$  is the number of active quark flavors. Since, the spin-2 resonance couples to the SM particles through energy momentum tensor (eqn.(2.1)) which is conserved, the coupling constant  $\kappa$  is protected from any UV renormalization. Hence, there will be no additional UV renormalization required other than the strong coupling constant renormalization. Using the eqn.(2.9), we now can express  $|\mathcal{M}\rangle$  (eqn.(2.8)) in powers of renormalized  $a_s$  with UV finite matrix elements  $|\mathcal{M}^{(i)}\rangle$

$$|\mathcal{M}\rangle = (a_s)^{\frac{1}{2}} \left( |\mathcal{M}^{(0)}\rangle + a_s |\mathcal{M}^{(1)}\rangle + a_s^2 |\mathcal{M}^{(2)}\rangle + \mathcal{O}(a_s^3) \right) \quad (2.11)$$

where

$$\begin{aligned} |\mathcal{M}^{(0)}\rangle &= \left( \frac{1}{\mu_R^\epsilon} \right)^{\frac{1}{2}} |\hat{\mathcal{M}}^{(0)}\rangle, \\ |\mathcal{M}^{(1)}\rangle &= \left( \frac{1}{\mu_R^\epsilon} \right)^{\frac{3}{2}} \left[ |\hat{\mathcal{M}}^{(1)}\rangle + \mu_R^\epsilon \frac{r_1}{2} |\hat{\mathcal{M}}^{(0)}\rangle \right], \\ |\mathcal{M}^{(2)}\rangle &= \left( \frac{1}{\mu_R^\epsilon} \right)^{\frac{5}{2}} \left[ |\hat{\mathcal{M}}^{(2)}\rangle + \mu_R^\epsilon \frac{3r_1}{2} |\hat{\mathcal{M}}^{(1)}\rangle + \mu_R^{2\epsilon} \left( \frac{r_2}{2} - \frac{r_1^2}{8} \right) |\hat{\mathcal{M}}^{(0)}\rangle \right] \end{aligned} \quad (2.12)$$

with

$$r_1 = \frac{2\beta_0}{\epsilon}, \quad r_2 = \left( \frac{4\beta_0^2}{\epsilon^2} + \frac{\beta_1}{\epsilon} \right). \quad (2.13)$$

## 2.4 Infrared factorization

Beyond leading order, the UV renormalized matrix elements  $|\mathcal{M}^{(i)}\rangle$ ,  $i > 0$  contain divergences arising from the infrared sector of massless QCD. They result from soft gluons and collinear massless partons present in the loops. They will cancel against similar divergences coming from real emission contributions in the infrared safe observables order by order in  $a_s$ , thanks to KLN theorem [36, 37]. The infrared divergence structure and their factorization property in QCD amplitudes have been well studied for long time. In [30], Catani predicted the infrared divergences of multi-parton QCD amplitudes precisely in dimensional regularization up to two loops excluding two loop single pole in  $\epsilon$ . In [31], Sterman and Tejeda-Yeomans provided a systematic way of understanding the structure of infrared divergences using factorization properties of the scattering amplitudes along with infrared evolution equations. They demonstrated the connection of single pole in  $\epsilon$  to a soft anomalous dimension matrix, later computed in [38, 39]. The structure of single pole term for the electromagnetic and Higgs form factors was first shown in [40, 41]. Using soft collinear effective field theory, Becher and Neubert [42] derived the exact formula for the infra-red divergences of scattering amplitudes with an arbitrary number of loops and legs in massless QCD including single pole in dimensional regularization. Using Wilson lines

for hard partons and soft and eikonal jet functions in dimensional regularization, Gardi and Magnea also arrived at a similar all order result [43].

According to Catani's prediction, the renormalized amplitudes  $|\mathcal{M}^{(i)}\rangle$  for the process (eqn.(2.3)) can be expressed in terms of the universal subtraction operators  $\mathbf{I}_g^{(i)}(\epsilon)$  as follows<sup>1</sup>

$$\begin{aligned} |\mathcal{M}^{(1)}\rangle &= 2 \mathbf{I}_g^{(1)}(\epsilon) |\mathcal{M}^{(0)}\rangle + |\mathcal{M}^{(1)fin}\rangle \\ |\mathcal{M}^{(2)}\rangle &= 2 \mathbf{I}_g^{(1)}(\epsilon) |\mathcal{M}^{(1)}\rangle + 4 \mathbf{I}_g^{(2)}(\epsilon) |\mathcal{M}^{(0)}\rangle + |\mathcal{M}^{(2)fin}\rangle \end{aligned} \quad (2.14)$$

where,

$$\begin{aligned} \mathbf{I}_g^{(1)}(\epsilon) &= \frac{1}{2} \frac{e^{-\frac{\epsilon}{2}\gamma_E}}{\Gamma(1+\frac{\epsilon}{2})} \mathcal{V}_g^{sing}(\epsilon) \left[ \left(-\frac{s}{\mu_R^2}\right)^{\frac{\epsilon}{2}} + \left(-\frac{t}{\mu_R^2}\right)^{\frac{\epsilon}{2}} + \left(-\frac{u}{\mu_R^2}\right)^{\frac{\epsilon}{2}} \right] \\ \mathbf{I}_g^{(2)}(\epsilon) &= -\frac{1}{2} \mathbf{I}_g^{(1)}(\epsilon) \left[ \mathbf{I}_g^{(1)}(\epsilon) - \frac{2\beta_0}{\epsilon} \right] + \frac{e^{\frac{\epsilon}{2}\gamma_E} \Gamma(1+\epsilon)}{\Gamma(1+\frac{\epsilon}{2})} \left[ -\frac{\beta_0}{\epsilon} + K \right] \mathbf{I}_g^{(1)}(2\epsilon) \\ &\quad + \mathbf{H}_g^{(2)}(\epsilon) \end{aligned} \quad (2.15)$$

and

$$\mathcal{V}_g^{sing}(\epsilon) = C_A \frac{4}{\epsilon^2} - \frac{\beta_0}{\epsilon}, \quad K = \left( \frac{67}{18} - \frac{\pi^2}{6} \right) C_A - \frac{10}{9} T_F n_f \quad (2.16)$$

$$\mathbf{H}_g^{(2)}(\epsilon) = \frac{3}{2\epsilon} \left\{ C_A^2 \left( -\frac{5}{12} - \frac{11}{24} \zeta_2 - \frac{1}{2} \zeta_3 \right) + C_A n_f \left( \frac{29}{27} + \frac{1}{12} \zeta_2 \right) - \frac{1}{2} C_F n_f - \frac{5}{27} n_f^2 \right\} \quad (2.17)$$

### 3 Calculation of two-loop amplitude

We now describe the computation of  $\langle \mathcal{M}^{(0)} | \mathcal{M}^{(1)} \rangle$  &  $\langle \mathcal{M}^{(0)} | \mathcal{M}^{(2)} \rangle$  matrix elements where all the Lorentz and color indices of external particles are summed over. The computation involves large number of Feynman diagrams. We need to perform various algebraic simplifications with Dirac, Lorentz and color indices before the loop integrals are evaluated. Due to tensorial coupling of spin-2 resonance with the SM fields, the loops contain higher rank tensor integrals as compared to the ones normally encountered in the SM processes. We have systematically automated this computation using various symbolic manipulation programs developed in house and few publicly available packages that use FORM [44] and Mathematica. In the following, we describe the method in detail.

#### 3.1 Feynman diagrams and simplification

We use QGRAF [45] to generate the Feynman diagrams. We find that there are 4 diagrams at tree level, 108 at one loop and 2362 at two loops, leaving out tadpole and self energy corrections to the external legs. The output of the QGRAF is then converted to the format that is suitable for further symbolic manipulation using FORM and Mathematica. A set of

<sup>1</sup>The numerical coefficients 2 and 4 with  $\mathbf{I}^{(i)}$  come due to the different definition of  $a_s$  between ours and Catani.

FORM routines is used to perform simplification of the squared matrix elements involving gluon and spin-2 resonance polarization and color sums. We have used Feynman gauge throughout and for the external on-shell gluon legs, physical polarizations are summed using

$$\sum_s \varepsilon^\mu(p_i, s) \varepsilon^{\nu*}(p_i, s) = -g^{\mu\nu} + \frac{p_i^\mu q_i^\nu + q_i^\mu p_i^\nu}{p \cdot q} \quad (3.1)$$

where,  $p_i$  is the  $i^{\text{th}}$ -gluon momentum and  $q_i$  is the corresponding reference momentum which is an arbitrary light-like 4-vector. We choose  $q_1 = p_2$ ,  $q_2 = p_1$  and  $q_3 = p_1$  for simplicity. The spin-2 polarization sum in  $d$  dimensions is given by [11]

$$\begin{aligned} B^{\mu\nu;\rho\sigma}(q) &= \left( g^{\mu\rho} - \frac{q^\mu q^\rho}{q \cdot q} \right) \left( g^{\nu\sigma} - \frac{q^\nu q^\sigma}{q \cdot q} \right) + \left( g^{\mu\sigma} - \frac{q^\mu q^\sigma}{q \cdot q} \right) \left( g^{\nu\rho} - \frac{q^\nu q^\rho}{q \cdot q} \right) \\ &\quad - \frac{2}{d-1} \left( g^{\mu\nu} - \frac{q^\mu q^\nu}{q \cdot q} \right) \left( g^{\rho\sigma} - \frac{q^\rho q^\sigma}{q \cdot q} \right) \end{aligned} \quad (3.2)$$

### 3.2 Reduction of tensor integrals

Beyond leading order, the resulting expressions involve tensorial one and two loop integrals which need to be reduced to a set of scalar integrals using a convenient tensorial reduction procedure. Tensorial reduction is quite straightforward at one loop level but not so at two loop level and beyond. In addition, finding a minimal set of integrals after the tensorial reduction is important to achieve the task with large number of Feynman integrals. A systematic approach to deal with higher rank tensor integrals and large number of scalar integrals is to use Integration by parts (IBP) [46] and Lorentz invariant (LI) [47] identities.

The IBP identities follow from the fact that in the dimensional regularization, the integral of the total derivative with respect to any loop momenta vanishes, that is

$$\int \frac{d^d k_1}{(2\pi)^d} \cdots \int \frac{d^d k_L}{(2\pi)^d} \frac{\partial}{\partial k_i} \cdot \left( v_j \frac{1}{\prod_l \mathcal{D}_l^{n_l}} \right) = 0 \quad (3.3)$$

where  $n_l$  is an element of  $\vec{n} = (n_1, \dots, n_N)$  with  $n_l \in \mathbb{Z}$ ,  $L$  is the number of loops and  $\mathcal{D}_l$ s are propagators which depend on the loop and external momenta and also masses. The four vector  $v_j^\mu$  can be both loop and external momenta. Performing the differentiation on the left hand side and expressing the scalar products of  $k_i$  and  $p_j$  linearly in terms of  $\mathcal{D}_l$ 's, one obtains the IBP identities given by

$$\sum_i a_i J(b_{i,1} + n_1, \dots, b_{i,N} + n_N) = 0 \quad (3.4)$$

where

$$J(\vec{m}) = J(m_1, \dots, m_N) = \int \frac{d^d k_1}{(2\pi)^d} \cdots \frac{d^d k_L}{(2\pi)^d} \frac{1}{\prod_l \mathcal{D}_l^{m_l}} \quad (3.5)$$

with  $b_{i,j} \in \{-1, 0, 1\}$  and  $a_i$  are polynomial in  $n_j$ . The LI identities follow from the fact that the loop integrals are invariant under Lorentz transformations of the external momenta, that is

$$p_i^\mu p_j^\nu \left( \sum_k p_{k[\nu} \frac{\partial}{\partial p_k^{\mu]} \right) J(\vec{n}) = 0. \quad (3.6)$$



While these identities are useful to express the tensorial integrals in terms of a set of master integrals, in practice, the computation becomes tedious due to the appearance of large variety of Feynman integrals involving different set of propagators each requiring a set of IBP and LI identities independently. We have reduced such varieties to a few by shifting the loop momenta suitably using an in-house algorithm which uses FORM. For one-loop diagrams, we can express each Feynman integral to contain terms from one of the following three sets:

$$\{\mathcal{D}, \mathcal{D}_1, \mathcal{D}_{12}, \mathcal{D}_{123}\}, \{\mathcal{D}, \mathcal{D}_2, \mathcal{D}_{23}, \mathcal{D}_{123}\}, \{\mathcal{D}, \mathcal{D}_3, \mathcal{D}_{31}, \mathcal{D}_{123}\} \quad (3.7)$$

where,

$$\mathcal{D} = k_1^2, \mathcal{D}_i = (k_1 - p_i)^2, \mathcal{D}_{ij} = (k_1 - p_i - p_j)^2, \mathcal{D}_{ijk} = (k_1 - p_i - p_j - p_k)^2 \quad (3.8)$$

In each set in eqn.(3.7),  $\mathcal{D}$ 's are linearly independent and form a complete basis in the sense that any Lorentz invariant  $k_1 \cdot p_i$  can be expressed in terms of  $\mathcal{D}$ 's. At two loops, there are nine independent Lorentz invariants involving loop momenta  $k_1$  and  $k_2$ , namely  $\{(k_\alpha \cdot k_\beta), (k_\alpha \cdot p_i)\}, \alpha, \beta = 1, 2; i = 1, \dots, 3$ . After appropriate shifting of loop momenta, we can express each two loop Feynman integral to contain terms belonging to one of the following six sets:

$$\begin{aligned} &\{\mathcal{D}_0, \mathcal{D}_1, \mathcal{D}_2, \mathcal{D}_{1;1}, \mathcal{D}_{2;1}, \mathcal{D}_{1;12}, \mathcal{D}_{2;12}, \mathcal{D}_{1;123}, \mathcal{D}_{2;123}\} \\ &\{\mathcal{D}_0, \mathcal{D}_1, \mathcal{D}_2, \mathcal{D}_{1;2}, \mathcal{D}_{2;2}, \mathcal{D}_{1;23}, \mathcal{D}_{2;23}, \mathcal{D}_{1;123}, \mathcal{D}_{2;123}\} \\ &\{\mathcal{D}_0, \mathcal{D}_1, \mathcal{D}_2, \mathcal{D}_{1;3}, \mathcal{D}_{2;3}, \mathcal{D}_{1;31}, \mathcal{D}_{2;31}, \mathcal{D}_{1;123}, \mathcal{D}_{2;123}\} \\ &\{\mathcal{D}_0, \mathcal{D}_1, \mathcal{D}_2, \mathcal{D}_{1;1}, \mathcal{D}_{2;1}, \mathcal{D}_{0;3}, \mathcal{D}_{1;12}, \mathcal{D}_{2;12}, \mathcal{D}_{1;123}\} \\ &\{\mathcal{D}_0, \mathcal{D}_1, \mathcal{D}_2, \mathcal{D}_{1;2}, \mathcal{D}_{2;2}, \mathcal{D}_{0;1}, \mathcal{D}_{1;23}, \mathcal{D}_{2;23}, \mathcal{D}_{1;123}\} \\ &\{\mathcal{D}_0, \mathcal{D}_1, \mathcal{D}_2, \mathcal{D}_{1;3}, \mathcal{D}_{2;3}, \mathcal{D}_{0;2}, \mathcal{D}_{1;31}, \mathcal{D}_{2;31}, \mathcal{D}_{1;123}\} \end{aligned} \quad (3.9)$$

where,

$$\begin{aligned} \mathcal{D}_0 &= (k_1 - k_2)^2, \mathcal{D}_\alpha = k_\alpha^2, \mathcal{D}_{\alpha;i} = (k_\alpha - p_i)^2, \mathcal{D}_{\alpha;ij} = (k_\alpha - p_i - p_j)^2, \\ \mathcal{D}_{0;i} &= (k_1 - k_2 - p_i)^2, \mathcal{D}_{\alpha;ijk} = (k_\alpha - p_i - p_j - p_k)^2 \end{aligned} \quad (3.10)$$

Given the fewer number of sets (eqns.(3.7) & (3.9)), it is easier to use IBP and LI identities using Laporta algorithm [48]. These identities can be generated using publicly available packages such as AIR [49], FIRE [50], REDUZE [51, 52], LiteRed [53, 54] etc. For our computation, we use a Mathematica based package LiteRedV1.51 along with MintV1.1 [55]. This package has the option to exploit symmetry relations within each set and also among different sets.

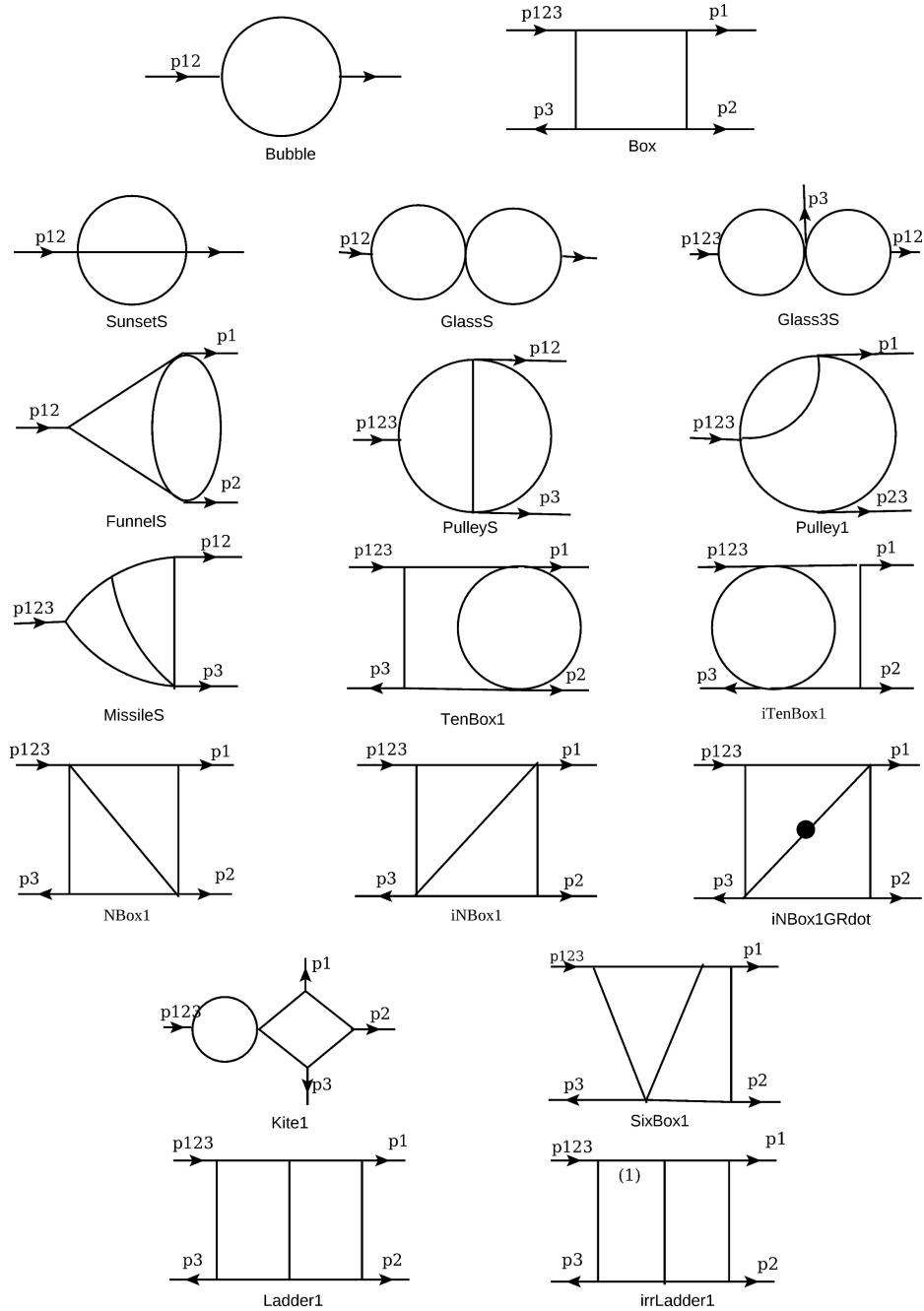
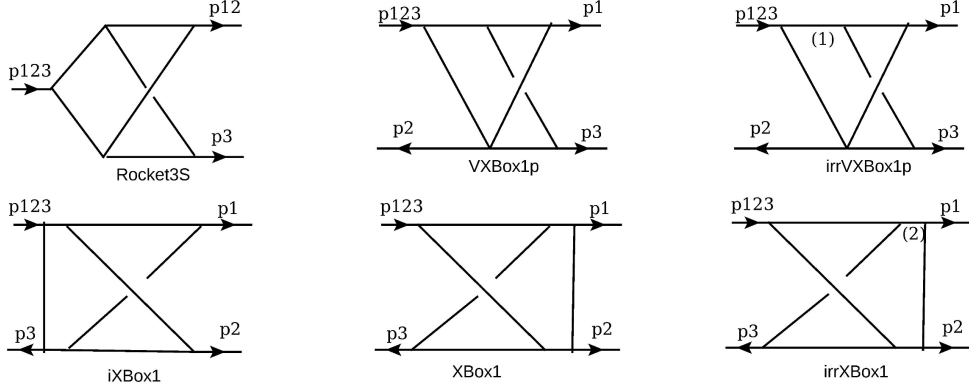

Figure 1. Planar topologies of master integrals

### 3.3 Master integrals

Using these IBP and LI identities, we reduce all the integrals that appear in our computation to a minimal set of master integrals. For one loop, we get two topologically different master integrals namely box and bubble, see Fig.(1) and we find that the master integrals with three propagators are absent. For two loops, we encounter 16 planar and 5 non-planar topologies of master integrals. These master integrals can be related to those that were



**Figure 2.** Non-Planar topologies of master integrals

computed by Gehrmann and Remiddi in their seminal papers [34, 35]. In particular, our set of master integrals does not contain integrals with irreducible numerator, instead we have higher power of propagators. We use IBP and LI identities to express our set of master integrals to those of [34, 35]. All the master integrals are drawn in Fig.(1) and Fig.(2) up to different permutations of the external momenta  $p_1, p_2$  and  $p_3$ . We also observe that some topologies like iXBox1 given in Fig.(2) are absent in our final result and find some new topologies namely Glass3S and Kite1 given in Fig.(1) which are absent in the [34, 35] and those are simply a product of two one loop topologies.

Substituting the master integrals computed by Gehrmann and Remiddi [34, 35] in terms of HPLs and 2dHPLs, we obtain the unrenormalized matrix elements  $\langle \hat{\mathcal{M}}^{(0)} | \hat{\mathcal{M}}^{(1)} \rangle$  and  $\langle \hat{\mathcal{M}}^{(0)} | \hat{\mathcal{M}}^{(2)} \rangle$ . We use shuffle algebra to express product of lower weight HPLs as a sum of higher weight HPLs. In the next section we present our results.

## 4 Results

The UV renormalized matrix elements  $\langle \mathcal{M}^{(0)} | \mathcal{M}^{(1)} \rangle$  and  $\langle \mathcal{M}^{(0)} | \mathcal{M}^{(2)} \rangle$  are computed using the unrenormalized counter parts through

$$\begin{aligned}
 \langle \mathcal{M}^{(0)} | \mathcal{M}^{(1)} \rangle &= \left( \frac{1}{\mu_R^\epsilon} \right)^2 \left[ \langle \hat{\mathcal{M}}^{(0)} | \hat{\mathcal{M}}^{(1)} \rangle + \mu_R^\epsilon \frac{r_1}{2} \langle \hat{\mathcal{M}}^{(0)} | \hat{\mathcal{M}}^{(0)} \rangle \right], \\
 \langle \mathcal{M}^{(0)} | \mathcal{M}^{(2)} \rangle &= \left( \frac{1}{\mu_R^\epsilon} \right)^3 \left[ \langle \hat{\mathcal{M}}^{(0)} | \hat{\mathcal{M}}^{(2)} \rangle + \mu_R^\epsilon \frac{3r_1}{2} \langle \hat{\mathcal{M}}^{(0)} | \hat{\mathcal{M}}^{(1)} \rangle \right. \\
 &\quad \left. + \mu_R^{2\epsilon} \left( \frac{r_2}{2} - \frac{r_1^2}{8} \right) \langle \hat{\mathcal{M}}^{(0)} | \hat{\mathcal{M}}^{(0)} \rangle \right]. \tag{4.1}
 \end{aligned}$$

Using eqn.(2.14), we can also express the renormalized matrix elements in terms of  $\mathbf{I}_g^{(i)}(\epsilon)$ , given by

$$\begin{aligned}
 \langle \mathcal{M}^{(0)} | \mathcal{M}^{(1)} \rangle &= 2 \mathbf{I}_g^{(1)}(\epsilon) \langle \mathcal{M}^{(0)} | \mathcal{M}^{(0)} \rangle + \langle \mathcal{M}^{(0)} | \mathcal{M}^{(1)fin} \rangle, \\
 \langle \mathcal{M}^{(0)} | \mathcal{M}^{(2)} \rangle &= 2 \mathbf{I}_g^{(1)}(\epsilon) \langle \mathcal{M}^{(0)} | \mathcal{M}^{(1)} \rangle + 4 \mathbf{I}_g^{(2)}(\epsilon) \langle \mathcal{M}^{(0)} | \mathcal{M}^{(0)} \rangle + \langle \mathcal{M}^{(0)} | \mathcal{M}^{(2)fin} \rangle. \tag{4.2}
 \end{aligned}$$

Expanding the right hand side of equations (4.1 & 4.2) in powers of  $\epsilon$  and comparing their coefficients of  $\mathcal{O}(\epsilon^0)$ , we obtain  $\langle \mathcal{M}^{(0)} | \mathcal{M}^{(1)fin} \rangle$  and  $\langle \mathcal{M}^{(0)} | \mathcal{M}^{(2)fin} \rangle$ .

We find that all the poles in  $\epsilon$  resulting from the soft and collinear partons in eqn.(4.1) are in agreement with those of eqn.(4.2). This serves as an important check on our result. In addition, it establishes the universal structure of infrared poles in QCD amplitudes involving tensorial operator insertion. We also observe that the contributions resulting from the gauge fixing term in eqn.(2.1) cancel exactly with those of ghosts confirming the gauge independence of our result. As we anticipated, the eqn.(4.1) does not require any over all operator renormalization constant due to the conservation of energy momentum tensor and it can be made UV finite through strong coupling constant renormalization (eqn.(2.9)) alone. Below we present our final results

$$\begin{aligned}
\langle \mathcal{M}^{(0)} | \mathcal{M}^{(0)} \rangle &= \mathcal{F}_h \mathcal{A}^{(0)}, \\
\langle \mathcal{M}^{(0)} | \mathcal{M}^{(1)fin} \rangle &= \mathcal{F}_h \left\{ -\frac{\beta_0}{2} \mathcal{A}^{(0)} \ln \left( -\frac{Q^2}{\mu^2} \right) + \left( \mathcal{A}_1^{(1)} \zeta_2 + \mathcal{A}_2^{(1)} \right) \right\}, \\
\langle \mathcal{M}^{(0)} | \mathcal{M}^{(2)fin} \rangle &= \mathcal{F}_h \left\{ \frac{3\beta_0^2}{8} \mathcal{A}^{(0)} \ln^2 \left( -\frac{Q^2}{\mu^2} \right) \right. \\
&\quad + \left( -3 C_A^2 \zeta_3 \mathcal{A}^{(0)} + \mathcal{A}_1^{(2)} \zeta_2 + \mathcal{A}_2^{(2)} \right) \ln \left( -\frac{Q^2}{\mu^2} \right) \\
&\quad \left. + \left( \mathcal{A}_3^{(2)} \zeta_2^2 + \mathcal{A}_4^{(2)} \zeta_3 + \mathcal{A}_5^{(2)} \zeta_2 + \mathcal{A}_6^{(2)} \right) \right\} \quad (4.3)
\end{aligned}$$

where,

$$\begin{aligned}
\mathcal{F}_h &= 16\pi^2 \kappa^2 N(N^2 - 1), \\
\mathcal{A}^{(0)} &= \frac{4}{stu} \left( s^4 + 2s^3(t+u) + 3s^2(t^2+u^2) + 2s(t^3+u^3) + (t^2+tu+u^2)^2 \right), \\
\mathcal{A}_\alpha^{(1)} &= \mathcal{A}_{\alpha;C_A}^{(1)} C_A + \mathcal{A}_{\alpha;n_f}^{(1)} n_f, \\
\mathcal{A}_\alpha^{(2)} &= \mathcal{A}_{\alpha;C_A^2}^{(2)} C_A^2 + \mathcal{A}_{\alpha;C_A n_f}^{(2)} C_A n_f + \mathcal{A}_{\alpha;C_F n_f}^{(2)} C_F n_f + \mathcal{A}_{\alpha;n_f^2}^{(2)} n_f^2. \quad (4.4)
\end{aligned}$$

The coefficients  $\mathcal{A}_{\alpha;C}^{(i)}$  are given in the appendix except  $\mathcal{A}_{6;C_A n_f}^{(2)}$ ,  $\mathcal{A}_{6;C_F n_f}^{(2)}$  &  $\mathcal{A}_{6;n_f^2}^{(2)}$  which can be found in the files A6Canf, A6Cfnf and A6nf2 respectively attached with this arXiv submission.

## 5 Conclusion

The computation of one and two loop QCD results for the process  $h \rightarrow g+g+g$  is presented. We use dimensional regularization to regulate both UV and IR divergences. Our result is

very general in the sense that it can be used for any scattering process involving production of a massive spin-2 particle that has a universal coupling with the SM fields. We can use it to study the production of a jet with missing energy due to KK graviton escaping the detector or a process with resonant massive spin-2 particle in association with a jet. Since the spin-2 field couples with the SM ones through rank-2 tensor, we not only encounter large number of Feynman diagrams but also the formidable challenge of reducing one and two loop Feynman integrals with high powers of loop momenta to scalar ones. The IBP and LI identities reduce all such integrals to only few master integrals that were already computed by Gehrmann and Remiddi. This computation is the first of the kind involving four point function at two loop level in QCD with tensorial insertion and one massive external state. We find that no overall UV renormalization is required due to the conservation of energy momentum tensor. We also find that our results exhibit the right IR structure confirming the factorization property of QCD amplitude even with tensorial insertion.

## Acknowledgement

MM, TA and NR thank for the hospitality provided by the Institute of Mathematical Sciences (IMSc) where the work was carried out. We thank the staff of IMSc computer center for their help. We sincerely thank T. Gehrmann for providing us the master integrals required for our computation. We thank R. N. Lee for his help with LiteRed, and A.V. Smirnov and V.A. Smirnov for their suggestions with FIRE. Finally, we would like to thank K. Hasegawa, M. K. Mandal and L. Tancredi for discussions and their valuable suggestions. NR, TA and MM also like to thank their parents and siblings for their wonderful love and continuous support.

## A Harmonic polylogarithms

In this section, we briefly describe the definition and properties of HPL and 2dHPL. HPL is represented by  $H(\vec{m}_w; y)$  with a  $w$ -dimensional vector  $\vec{m}_w$  of parameters and its argument  $y$ .  $w$  is called the weight of the HPL. The elements of  $\vec{m}_w$  belong to  $\{1, 0, -1\}$  through which the following rational functions are represented

$$f(1; y) \equiv \frac{1}{1-y}, \quad f(0; y) \equiv \frac{1}{y}, \quad f(-1; y) \equiv \frac{1}{1+y}. \quad (\text{A.1})$$

The weight 1 ( $w = 1$ ) HPLs are defined by

$$H(1, y) \equiv -\ln(1-y), \quad H(0, y) \equiv \ln y, \quad H(-1, y) \equiv \ln(1+y). \quad (\text{A.2})$$

For  $w > 1$ ,  $H(m, \vec{m}_w; y)$  is defined by

$$H(m, \vec{m}_w; y) \equiv \int_0^y dx f(m, x) H(\vec{m}_w; x), \quad m \in 0, \pm 1. \quad (\text{A.3})$$

The 2dHPLs are defined in the same way as eqn.(A.3) with the new elements  $\{2, 3\}$  in  $\vec{m}_w$  representing a new class of rational functions

$$f(2; y) \equiv f(1-z; y) \equiv \frac{1}{1-y-z}, \quad f(3; y) \equiv f(z; y) \equiv \frac{1}{y+z} \quad (\text{A.4})$$

and correspondingly with the weight 1 ( $w = 1$ ) 2dHPLs

$$H(2, y) \equiv -\ln\left(1 - \frac{y}{1-z}\right), \quad H(3, y) \equiv \ln\left(\frac{y+z}{z}\right). \quad (\text{A.5})$$

### Properties

Shuffle algebra : A product of two HPL with weights  $w_1$  and  $w_2$  of the same argument  $y$  is a combination of HPLs with weight  $(w_1 + w_2)$  and argument  $y$ , such that all possible permutations of the elements of  $\vec{m}_{w_1}$  and  $\vec{m}_{w_2}$  are considered preserving the relative orders of the elements of  $\vec{m}_{w_1}$  and  $\vec{m}_{w_2}$ ,

$$H(\vec{m}_{w_1}; y)H(\vec{m}_{w_2}; y) = \sum_{\vec{m}_w = \vec{m}_{w_1} \uplus \vec{m}_{w_2}} H(\vec{m}_w; y). \quad (\text{A.6})$$

Integration-by-parts identities : The ordering of the elements of  $\vec{m}_w$  in an HPL with weight  $w$  and argument  $y$  can be reversed using integration-by-parts and in the process, some products of two HPLs are generated in the following way

$$\begin{aligned} H(\vec{m}_w; y) \equiv H(m_1, m_2, \dots, m_w; y) &= H(m_1, y)H(m_2, \dots, m_w; y) \\ &\quad - H(m_2, m_1, y)H(m_3, \dots, m_w; y) \\ &\quad + \dots + (-1)^{w+1}H(m_w, \dots, m_2, m_1; y). \end{aligned} \quad (\text{A.7})$$

## B One-loop coefficients

$$\mathcal{A}_{1;C_A}^{(1)} = -\frac{4}{stu} \left( s^4 + 2s^3(t+u) + 3s^2(t^2+u^2) + 2s(t^3+u^3) + t^4 + u^4 \right)$$

$$\mathcal{A}_{1;n_f}^{(1)} = -\frac{2}{s} (t^2 + u^2)$$

$$\begin{aligned} \mathcal{A}_{2;C_A}^{(1)} = & \left\{ -6(t+u)^4 (11s^8 + 22(3t+u)s^7 + (187t^2 + 64ut + 33u^2)s^6 + (330t^3 + 60ut^2 + 78u^2t + 22u^3)s^5 + (396t^4 + 14ut^3 \right. \\ & + 51u^2t^2 + 36u^3t + 11u^4)s^4 + 2t(165t^4 + 7u^3t^3 + 6u^2t^2 + 7u^3t + 10u^4)s^3 + t^2(187t^4 + 60ut^3 + 51u^2t^2 + 14u^3t + 24u^4)s^2 \\ & + 2t^3(33t^4 + 32ut^3 + 39u^2t^2 + 18u^3t + 10u^4)s + 11t^4(t^2 + ut + u^2)^2 H(0, y)(s+u)^4 - 36(s+t)^4(t+u)^4 (s^4 + 2(t+u)s^3 \\ & + 3(t^2+u^2)s^2 + 2(t^3+u^3)s + t^4 + u^4) H(0, y)H(0, z)(s+u)^4 + 6(s+t)^4 \left( (11t^4 + 20ut^3 + 24u^2t^2 + 20u^3t + 11u^4)s^4 \right. \\ & + 2(11t^5 + 18ut^4 + 7u^2t^3 + 7u^3t^2 + 18u^4t + 11u^5)s^3 + 3(t+u)^2 (11t^4 + 4ut^3 - 2u^2t^2 + 4u^3t + 11u^4)s^2 + 2(t+u)^3 (11t^4 \\ & - ut^3 - u^3t + 11u^4)s + 11(t+u)^4 (t^2 + ut + u^2)^2 \left. \right) H(1, z)(s+u)^4 + 36(s+t)^4(t+u)^4 (s^4 + 2ts^3 + 3t^2s^2 + 2t^3s + (t^2 + ut \\ & + u^2)^2) H(0, y)H(1, z)(s+u)^4 + 6(s+t)^4 \left( (11t^4 + 20ut^3 + 24u^2t^2 + 20u^3t + 11u^4)s^4 + 2(11t^5 + 18ut^4 + 7u^2t^3 + 7u^3t^2 \right. \\ & + 18u^4t + 11u^5)s^3 + 3(t+u)^2 (11t^4 + 4ut^3 - 2u^2t^2 + 4u^3t + 11u^4)s^2 + 2(t+u)^3 (11t^4 - ut^3 - u^3t + 11u^4)s + 11(t+u)^4 (t^2 \\ & + ut + u^2)^2 \left. \right) H(2, y)(s+u)^4 + 36(s+t)^4(t+u)^4 (s^4 + 2us^3 + 3u^2s^2 + 2u^3s + (t^2 + ut + u^2)^2) H(0, z)H(2, y)(s+u)^4 \\ & - 36(s+t)^4(t+u)^4 (2s^4 + 2(t+u)s^3 + 3(t^2+u^2)s^2 + 2(t^3+u^3)s + 2(t^2+ut+u^2)^2) H(1, z)H(3, y)(s+u)^4 \\ & - 36(s+t)^4(t+u)^4 (s^4 + 2ts^3 + 3t^2s^2 + 2t^3s + (t^2 + ut + u^2)^2) H(0, 1, z)(s+u)^4 + 36(s+t)^4(t+u)^4 (s^4 + 2t^3s^3 \\ & + 3t^2s^2 + 2t^3s + (t^2 + ut + u^2)^2) H(0, 2, y)(s+u)^4 - 36(s+t)^4(t+u)^4 (2s^4 + 2(2t+u)s^3 + 3(2t^2+u^2)s^2 + 2(2t^3 \\ & + u^3)s + 2t^4 + 2u^4 + 2tu^3 + 3t^2u^2 + 2t^3u) H(1, 0, y)(s+u)^4 - 36(s+t)^4(t+u)^4 (s^4 + 2(t+u)s^3 + 3(t^2+u^2)s^2 + 2(t^3 \\ & + u^3)s + t^4 + u^4) H(1, 0, z)(s+u)^4 + 36(s+t)^4(t+u)^4 (s^4 + 2ts^3 + 3t^2s^2 + 2t^3s + (t^2 + ut + u^2)^2) H(2, 0, y)(s+u)^4 \\ & - 36(s+t)^4(t+u)^4 (2s^4 + 2(t+u)s^3 + 3(t^2+u^2)s^2 + 2(t^3+u^3)s + 2(t^2+ut+u^2)^2) H(3, 2, y)(s+u)^4 \\ & - 2(s+t)(t+u) (203(t+u)^3 s^{10} + 2(506t^4 + 1988ut^3 + 2973u^2t^2 + 1988u^3t + 506u^4) s^9 + 3(807t^5 + 3709ut^4 + 7123u^2t^3 \\ & + 7123u^3t^2 + 3709u^4t + 807u^5) s^8 + 3(1208t^6 + 6186ut^5 + 13887u^2t^4 + 17836u^3t^3 + 13887u^4t^2 + 6186u^5t + 1208u^6) s^7 \\ & + (3624t^7 + 21596ut^6 + 54318u^2t^5 + 80567u^3t^4 + 80567u^4t^3 + 54318u^5t^2 + 21596u^6t + 3624u^7) s^6 + 3(807t^8 + 6186ut^7 \\ & + 18106u^2t^6 + 29776u^3t^5 + 34116u^4t^4 + 29776u^5t^3 + 18106u^6t^2 + 6186u^7t + 807u^8) s^5 + (1012t^9 + 11127ut^8 + 41661u^2t^7 \\ & + 80567u^3t^6 + 102348u^4t^5 + 102348u^5t^4 + 80567u^6t^3 + 41661u^7t^2 + 11127u^8t + 1012u^9) s^4 + (203t^{10} + 3976ut^9 + 21369u^2t^8 \\ & + 53508u^3t^7 + 80567u^4t^6 + 89328u^5t^5 + 80567u^6t^4 + 53508u^7t^3 + 21369u^8t^2 + 3976u^9t + 203u^{10}) s^3 + 3tu(203t^9 + 1982ut^8 \\ & + 7123u^2t^7 + 13887u^3t^6 + 18106u^4t^5 + 18106u^5t^4 + 13887u^6t^3 + 7123u^7t^2 + 1982u^8t + 203u^9) s^2 + t^2u^2(t+u)^2 (609t^6 \\ & + 2758ut^5 + 5002u^2t^4 + 5796u^3t^3 + 5002u^4t^2 + 2758u^5t + 609u^6) s + t^3u^3(t+u)^3 (203t^4 + 403u^3t^3 + 603u^2t^2 + 403u^3t \\ & + 203u^4) (s+u) - 6(s+t)^4(t+u)^4 (11s^8 + 22(t+3u)s^7 + (33t^2 + 64ut + 187u^2)s^6 + (22t^3 + 78ut^2 + 60u^2t + 330u^3)s^5 \\ & + (11t^4 + 36ut^3 + 51u^2t^2 + 14u^3t + 396u^4)s^4 + 2u(10t^4 + 7ut^3 + 6u^2t^2 + 7u^3t + 165u^4)s^3 + u^2(24t^4 + 14ut^3 + 51u^2t^2 + 60u^3t \\ & + 187u^4) s^2 + 2u^3(10t^4 + 18ut^3 + 39u^2t^2 + 32u^3t + 33u^4) s + 11u^4 (t^2 + ut + u^2)^2 H(0, z) \left. \right\} / (9st(s+t)^4 u(s+u)^4 (t+u)^4) \end{aligned}$$

$$\begin{aligned} \mathcal{A}_{2;n_f}^{(1)} = & \left\{ -18u(s+u)^4(t+u)^4 (s^2 - ts + t^2 + u^2) H(1, 0, y)(s+t)^5 + 6(t+u)^4 (2s^8 + 4(t+3u)s^7 + 2(3t^2 + 5ut + 17u^2) s^6 \right. \\ & + (4t^3 + 15ut^2 + 6u^2t + 60u^3)s^5 + 2(t^4 + 12u^2t^2 - 2u^3t + 36u^4)s^4 + 2u(t^4 - 2ut^3 + 15u^2t^2 - 2u^3t + 30u^4)s^3 \\ & + 2u^2(3t^4 - 2ut^3 + 12u^2t^2 + 3u^3t + 17u^4) s^2 + (12u^7 + 10tu^6 + 15t^2u^5 + 2t^4u^3) s + 2u^4(t^2 + ut + u^2)^2 H(0, z)(s+t)^4 \\ & - 18tu(s+u)^4(t+u)^4 (t^2 + u^2) H(0, y)H(0, z)(s+t)^4 - 6(s+u)^4 (2(t^4 + ut^3 + 3u^2t^2 + u^3t + u^4)s^4 + 4(t^5 - u^2t^3 \\ & - u^3t^2 + u^5) s^3 + 3(t+u)^2 (2t^4 + ut^3 + 4u^2t^2 + u^3t + 2u^4)s^2 + 2(t+u)^3 (2t^4 - ut^3 - u^3t + 2u^4) s + 2(t+u)^4 (t^2 + ut \\ & + u^2)^2 \left. \right) H(1, z)(s+t)^4 + 18su(s+u)^4(t+u)^4 (s^2 + u^2) H(0, y)H(1, z)(s+t)^4 - 6(s+u)^4 (2(t^4 + ut^3 + 3u^2t^2 + u^3t \\ & + u^4)s^4 + 4(t^5 - u^2t^3 - u^3t^2 + u^5) s^3 + 3(t+u)^2 (2t^4 + ut^3 + 4u^2t^2 + u^3t + 2u^4)s^2 + 2(t+u)^3 (2t^4 - ut^3 - u^3t + 2u^4) s \\ & + 2(t+u)^4 (t^2 + ut + u^2)^2 \left. \right) H(2, y)(s+t)^4 + 18st(s^2 + t^2)(s+u)^4 (t+u)^4 H(0, z)H(2, y)(s+t)^4 - 18s(s+u)^4(t+u)^5 (s^2 \\ & + t^2 + u^2 - t u) H(1, z)H(3, y)(s+t)^4 - 18su(s+u)^4(t+u)^4 (s^2 + u^2) H(0, 1, z)(s+t)^4 + 18su(s+u)^4(t+u)^4 (s^2 \\ & + u^2) H(0, 2, y)(s+t)^4 - 18tu(s+u)^4(t+u)^4 (t^2 + u^2) H(1, 0, z)(s+t)^4 + 18su(s+u)^4(t+u)^4 (s^2 + u^2) H(2, 0, y)(s+t)^4 \end{aligned}$$

$$\begin{aligned}
& -18s(s+u)^4(t+u)^5 (s^2+t^2+u^2-tu)H(3,2,y)(s+t)^4 + 2(s+u)(t+u)(35(t+u)^3 s^{10} + 2(86t^4 + 335ut^3 + 507u^2t^2 \\
& + 335u^3t + 86u^4)s^9 + 3(135t^5 + 607ut^4 + 1177u^2t^3 + 1177u^3t^2 + 607u^4t + 135u^5)s^8 + 3(200t^6 + 990ut^5 + 2211u^2t^4 \\
& + 2860u^3t^3 + 2211u^4t^2 + 990u^5t + 200u^6)s^7 + (600t^7 + 3428ut^6 + 8436u^2t^5 + 12593u^3t^4 + 12593u^4t^3 + 8436u^5t^2 \\
& + 3428u^6t + 600u^7)s^6 + 3(135t^8 + 990ut^7 + 2812u^2t^6 + 4612u^3t^5 + 5328u^4t^4 + 4612u^5t^3 + 2812u^6t^2 + 990u^7t + 135u^8)s^5 \\
& + (172t^9 + 1821ut^8 + 6633u^2t^7 + 12593u^3t^6 + 15984u^4t^5 + 15984u^5t^4 + 12593u^6t^3 + 6633u^7t^2 + 1821u^8t + 172u^9)s^4 \\
& + (35t^{10} + 670ut^9 + 3531u^2t^8 + 8580u^3t^7 + 12593u^4t^6 + 13836u^5t^5 + 12593u^6t^4 + 8580u^7t^3 + 3531u^8t^2 + 670u^9t \\
& + 35u^{10})s^3 + 3tu(35t^9 + 338ut^8 + 1177u^2t^7 + 2211u^3t^6 + 2812u^4t^5 + 2812u^5t^4 + 2211u^6t^3 + 1177u^7t^2 + 338u^8t + 35u^9)s^2 \\
& + t^2u^2(t+u)^2(105t^6 + 460ut^5 + 796u^2t^4 + 918u^3t^3 + 796u^4t^2 + 460u^5t + 105u^6)s + t^3u^3(t+u)^3(35t^4 + 67u^3t^3 + 99u^2t^2 \\
& + 67u^3t + 35u^4)(s+t) + 6(s+u)^4(t+u)^4(2s^8 + 4(3t+u)s^7 + 2(17t^2 + 5ut + 3u^2)s^6 + (60t^3 + 6u^2t^2 + 15u^2t \\
& + 4u^3)s^5 + 2(36t^4 - 2ut^3 + 12u^2t^2 + u^4)s^4 + 2t(30t^4 - 2ut^3 + 15u^2t^2 - 2u^3t + u^4)s^3 + 2t^2(17t^4 + 3ut^3 + 12u^2t^2 \\
& - 2u^3t + 3u^4)s^2 + (12t^7 + 10u^6t^6 + 15u^2t^5 + 2u^4t^3)s + 2t^4(t^2 + ut + u^2)^2)H(0,y)\} / (9st(s+t)^4u(s+u)^4(t+u)^4)
\end{aligned}$$

## C Two-loop coefficients

$$\mathcal{A}_{1;C_A^2}^{(2)} = \frac{11}{stu} (s^4 + 2s^3(t+u) + 3s^2(t^2+u^2) + 2s(t^3+u^3) + t^4 - 2t^3u - 3t^2u^2 - 2tu^3 + u^4)$$

$$\mathcal{A}_{1;C_A n_f}^{(2)} = -\frac{1}{stu} (2s^4 + 4s^3(t+u) + 6s^2(t^2+u^2) + 4s(t^3+u^3) + 2t^4 - 15t^3u - 6t^2u^2 - 15tu^3 + 2u^4)$$

$$\mathcal{A}_{1;C_F n_f}^{(2)} = 0$$

$$\mathcal{A}_{1;n_f^2}^{(2)} = -\frac{2}{s} (t^2 + u^2)$$

$$\begin{aligned}
\mathcal{A}_{2;C_A^2}^{(2)} = & \left\{ 33(t+u)^4(11s^8 + 22(3t+u)s^7 + (187t^2 + 64ut + 33u^2)s^6 + (330t^3 + 60ut^2 + 78u^2t + 22u^3)s^5 + (396t^4 + 14ut^3 + 51u^2t^2 \right. \\
& + 36u^3t + 11u^4)s^4 + 2t(165t^4 + 7u^3t^3 + 6u^2t^2 + 7u^3t + 10u^4)s^3 + t^2(187t^4 + 60ut^3 + 51u^2t^2 + 14u^3t + 24u^4)s^2 + 2t^3(33t^4 + 32ut^3 \\
& + 39u^2t^2 + 18u^3t + 10u^4)s + 11t^4(t^2 + ut + u^2)^2)H(0,y)(s+u)^4 + 198(s+t)^4(t+u)^4(s^4 + 2(t+u)s^3 + 3(t^2+u^2)s^2 + 2(t^3 \\
& + u^3)s + t^4 + u^4)H(0,y)H(0,z)(s+u)^4 - 33(s+t)^4((11t^4 + 20ut^3 + 24u^2t^2 + 20u^3t + 11u^4)s^4 + 2(11t^5 + 18ut^4 + 7u^2t^3 + 7u^3t^2 \\
& + 18u^4t + 11u^5)s^3 + 3(t+u)^2(11t^4 + 4ut^3 - 2u^2t^2 + 4u^3t + 11u^4)s^2 + 2(t+u)^3(11t^4 - ut^3 - u^3t + 11u^4)s + 11(t+u)^4(t^2 + ut \\
& + u^2)^2)H(1,z)(s+u)^4 - 198(s+t)^4(t+u)^4(s^4 + 2ts^3 + 3t^2s^2 + 2t^3s + (t^2 + ut + u^2)^2)H(0,y)H(1,z)(s+u)^4 - 33(s+t)^4((11t^4 \\
& + 20ut^3 + 24u^2t^2 + 20u^3t + 11u^4)s^4 + 2(11t^5 + 18ut^4 + 7u^2t^3 + 7u^3t^2 + 18u^4t + 11u^5)s^3 + 3(t+u)^2(11t^4 + 4ut^3 - 2u^2t^2 + 4u^3t \\
& + 11u^4)s^2 + 2(t+u)^3(11t^4 - ut^3 - u^3t + 11u^4)s + 11(t+u)^4(t^2 + ut + u^2)^2)H(2,y)(s+u)^4 - 198(s+t)^4(t+u)^4(s^4 + 2us^3 \\
& + 3u^2s^2 + 2u^3s + (t^2 + ut + u^2)^2)H(0,z)H(2,y)(s+u)^4 + 198(s+t)^4(t+u)^4(2s^4 + 2(t+u)s^3 + 3(t^2+u^2)s^2 + 2(t^3+u^3)s \\
& + 2(t^2+ut+u^2)^2)H(1,z)H(3,y)(s+u)^4 + 198(s+t)^4(t+u)^4(s^4 + 2ts^3 + 3t^2s^2 + 2t^3s + (t^2 + ut + u^2)^2)H(0,1,z)(s+u)^4 \\
& - 198(s+t)^4(t+u)^4(s^4 + 2t^3s^3 + 3t^2s^2 + 2t^3s + (t^2 + ut + u^2)^2)H(0,2,y)(s+u)^4 + 198(s+t)^4(t+u)^4(2s^4 + 2(2t+u)s^3 \\
& + 3(2t^2+u^2)s^2 + 2(2t^3+u^3)s + 2t^4 + 2u^4 + 2tu^3 + 3t^2u^2 + 2t^3u)H(1,0,y)(s+u)^4 + 198(s+t)^4(t+u)^4(s^4 + 2(t+u)s^3 \\
& + 3(t^2+u^2)s^2 + 2(t^3+u^3)s + t^4 + u^4)H(1,0,z)(s+u)^4 - 198(s+t)^4(t+u)^4(s^4 + 2ts^3 + 3t^2s^2 + 2t^3s + (t^2 + u^2 \\
& + u^2)^2)H(2,0,y)(s+u)^4 + 198(s+t)^4(t+u)^4(2s^4 + 2(t+u)s^3 + 3(t^2+u^2)s^2 + 2(t^3+u^3)s + 2(t^2+ut+u^2)^2)H(3,2,y)(s+u)^4
\end{aligned}$$



$$\begin{aligned}
& + (s+t)(t+u) \left( 1939(t+u)^3 s^{10} + (9662t^4 + 37856ut^3 + 56586u^2t^2 + 37856u^3t + 9662u^4) s^9 + 3(7701t^5 + 35213ut^4 + 67475u^2t^3 \right. \\
& + 67475u^3t^2 + 35213u^4t + 7701u^5) s^8 + 3(11524t^6 + 58638ut^5 + 131001u^2t^4 + 167972u^3t^3 + 131001u^4t^2 + 58638u^5t + 11524u^6) s^7 \\
& + (34572t^7 + 204628ut^6 + 511062u^2t^5 + 754525u^3t^4 + 754525u^4t^3 + 511062u^5t^2 + 204628u^6t + 34572u^7) s^6 + 3(7701t^8 \\
& + 58638ut^7 + 170354u^2t^6 + 278144u^3t^5 + 317652u^4t^4 + 278144u^5t^3 + 170354u^6t^2 + 58638u^7t + 7701u^8) s^5 + (9662t^9 + 105639ut^8 \\
& + 393003u^2t^7 + 754525u^3t^6 + 952956u^4t^5 + 952956u^5t^4 + 754525u^6t^3 + 393003u^7t^2 + 105639u^8t + 9662u^9) s^4 + (1939t^{10} + 37856ut^9 \\
& + 202425u^2t^8 + 503916u^3t^7 + 754525u^4t^6 + 834432u^5t^5 + 754525u^6t^4 + 503916u^7t^3 + 202425u^8t^2 + 37856u^9t + 1939u^{10}) s^3 \\
& + 3tu(1939t^9 + 18862ut^8 + 67475u^2t^7 + 131001u^3t^6 + 170354u^4t^5 + 170354u^5t^4 + 131001u^6t^3 + 67475u^7t^2 + 18862u^8t + 1939u^9) s^2 \\
& + t^2u^2(t+u)^2(5817t^6 + 26222ut^5 + 47378u^2t^4 + 54936u^3t^3 + 47378u^4t^2 + 26222u^5t + 5817u^6) s + t^3u^3(t+u)^3(1939t^4 + 3845u^2t^3 \\
& + 5751u^2t^2 + 3845u^3t + 1939u^4) \Big) (s+u) + 33(s+t)^4(t+u)^4 \left( 11s^8 + 22(t+3u)s^7 + (33t^2 + 64ut + 187u^2) s^6 + (22t^3 + 78ut^2 + 60u^2t \right. \\
& + 330u^3) s^5 + (11t^4 + 36ut^3 + 51u^2t^2 + 14u^3t + 396u^4) s^4 + 2u(10t^4 + 7ut^3 + 6u^2t^2 + 7u^3t + 165u^4) s^3 + u^2(24t^4 + 14ut^3 + 51u^2t^2 \\
& + 60u^3t + 187u^4) s^2 + 2u^3(10t^4 + 18ut^3 + 39u^2t^2 + 32u^3t + 33u^4) s + 11u^4(t^2 + ut + u^2)^2 H(0, z) \Big\} / (9st(s+t)^4u(s+u)^4(t+u)^4)
\end{aligned}$$

$$\begin{aligned}
\mathcal{A}_{2;C_A n_f}^{(2)} = & - \left\{ 3(t+u)^4(44s^8 + 88(3t+u)s^7 + 2(374t^2 + 119ut + 66u^2) s^6 + (1320t^3 + 186ut^2 + 321u^2t + 88u^3) s^5 + 2(792t^4 - 8ut^3 \right. \\
& + 183u^2t^2 + 36u^3t + 22u^4) s^4 + 2t(660t^4 - 8ut^3 + 177u^2t^2 - 8u^3t + 31u^4) s^3 + 2t^2(374t^4 + 93ut^3 + 183u^2t^2 - 8u^3t + 57u^4) s^2 \\
& + t^3(264t^4 + 238ut^3 + 321u^2t^2 + 72u^3t + 62u^4) s + 44t^4(t^2 + ut + u^2)^2 H(0, y)(s+u)^4 + 9(s+t)^4(t+u)^4(4s^4 + 8(t+u)s^3 \\
& + 12(t^2 + u^2) s^2 + 8(t^3 + u^3) s + 4t^4 + 4u^4 - 11tu^3 - 11t^3u) H(0, y)H(0, z)(s+u)^4 - 3(s+t)^4(2(22t^4 + 31ut^3 + 57u^2t^2 \\
& + 31u^3t + 22u^4) s^4 + 8(11t^5 + 9ut^4 - 2u^2t^3 - 2u^3t^2 + 9u^4t + 11u^5) s^3 + 3(t+u)^2(44t^4 + 19ut^3 + 40u^2t^2 + 19u^3t + 44u^4) s^2 \\
& + 2(t+u)^3(44t^4 - 13ut^3 - 13u^3t + 44u^4) s + 44(t+u)^4(t^2 + ut + u^2)^2 H(1, z)(s+u)^4 - 9(s+t)^4(t+u)^4(4s^4 + (8t-11u)s^3 \\
& + 12t^2s^2 + (8t^3 - 11u^3) s + 4(t^2 + ut + u^2)^2) H(0, y)H(1, z)(s+u)^4 - 3(s+t)^4(2(22t^4 + 31ut^3 + 57u^2t^2 + 31u^3t + 22u^4) s^4 \\
& + 8(11t^5 + 9ut^4 - 2u^2t^3 - 2u^3t^2 + 9u^4t + 11u^5) s^3 + 3(t+u)^2(44t^4 + 19ut^3 + 40u^2t^2 + 19u^3t + 44u^4) s^2 + 2(t+u)^3(44t^4 \\
& - 13ut^3 - 13u^3t + 44u^4) s + 44(t+u)^4(t^2 + ut + u^2)^2) H(2, y)(s+u)^4 - 9(s+t)^4(t+u)^4(4s^4 + (8u-11t)s^3 + 12u^2s^2 + (8u^3 \\
& - 11t^3) s + 4(t^2 + ut + u^2)^2) H(0, z)H(2, y)(s+u)^4 + 9(s+t)^4(t+u)^4(8s^4 - 3(t+u)s^3 + 12(t^2 + u^2) s^2 - 3(t^3 + u^3) s \\
& + 8(t^2 + ut + u^2)^2) H(1, z)H(3, y)(s+u)^4 + 9(s+t)^4(t+u)^4(4s^4 + (8t-11u)s^3 + 12t^2s^2 + (8t^3 - 11u^3) s + 4(t^2 + ut \\
& + u^2)^2) H(0, 1, z)(s+u)^4 - 9(s+t)^4(t+u)^4(4s^4 + (8t-11u)s^3 + 12t^2s^2 + (8t^3 - 11u^3) s + 4(t^2 + ut + u^2)^2) H(0, 2, y)(s+u)^4 \\
& + 9(s+t)^4(t+u)^4(8s^4 + (16t-3u)s^3 + 12(2t^2 + u^2) s^2 + (16t^3 - 3u^3) s + 8t^4 + 8u^4 - 3tu^3 + 12t^2u^2 - 3t^3u) H(1, 0, y)(s+u)^4 \\
& + 9(s+t)^4(t+u)^4(4s^4 + 8(t+u)s^3 + 12(t^2 + u^2) s^2 + 8(t^3 + u^3) s + 4t^4 + 4u^4 - 11tu^3 - 11t^3u) H(1, 0, z)(s+u)^4 \\
& - 9(s+t)^4(t+u)^4(4s^4 + (8t-11u)s^3 + 12t^2s^2 + (8t^3 - 11u^3) s + 4(t^2 + ut + u^2)^2) H(2, 0, y)(s+u)^4 + 9(s+t)^4(t+u)^4(8s^4 \\
& - 3(t+u)s^3 + 12(t^2 + u^2) s^2 - 3(t^3 + u^3) s + 8(t^2 + ut + u^2)^2) H(3, 2, y)(s+u)^4 + (s+t)(t+u)(499(t+u)^3s^{10} + 2(1228t^4 + 4741ut^3 \\
& + 7143u^2t^2 + 4741u^3t + 1228u^4) s^9 + 3(1931t^5 + 8547ut^4 + 16389u^2t^3 + 16389u^3t^2 + 8547u^4t + 1931u^5) s^8 + 3(2864t^6 \\
& + 13918ut^5 + 30487u^2t^4 + 39100u^3t^3 + 30487u^4t^2 + 13918u^5t + 2864u^6) s^7 + (8592t^7 + 48196u^6t + 115584u^2t^5 + 168841u^3t^4 \\
& + 168841u^4t^3 + 115584u^5t^2 + 48196u^6t + 8592u^7) s^6 + 3(1931t^8 + 13918ut^7 + 38528u^2t^6 + 61228u^3t^5 + 69608u^4t^4 \\
& + 61228u^5t^3 + 38528u^6t^2 + 13918u^7t + 1931u^8) s^5 + (2456t^9 + 25641ut^8 + 91461u^2t^7 + 168841u^3t^6 + 208824u^4t^5 \\
& + 208824u^5t^4 + 168841u^6t^3 + 91461u^7t^2 + 25641u^8t + 2456u^9) s^4 + (499t^{10} + 9482ut^9 + 49167u^2t^8 + 117300u^3t^7 + 168841u^4t^6 \\
& + 183684u^5t^5 + 168841u^6t^4 + 117300u^7t^3 + 49167u^8t^2 + 9482u^9t + 499u^{10}) s^3 + 3tu(499t^9 + 4762ut^8 + 16389u^2t^7 + 30487u^3t^6 \\
& + 38528u^4t^5 + 38528u^5t^4 + 30487u^6t^3 + 16389u^7t^2 + 4762u^8t + 499u^9) s^2 + t^2u^2(t+u)^2(1497t^6 + 6488ut^5 + 11168u^2t^4 \\
& + 12930u^3t^3 + 11168u^4t^2 + 6488u^5t + 1497u^6) s + t^3u^3(t+u)^3(499t^4 + 959ut^3 + 1419u^2t^2 + 959u^3t + 499u^4) \Big) (s+u) \\
& + 3(s+t)^4(t+u)^4(44s^8 + 88(t+3u)s^7 + 2(66t^2 + 119ut + 374u^2) s^6 + (88t^3 + 321ut^2 + 186u^2t + 1320u^3) s^5 + 2(22t^4 \\
& + 36ut^3 + 183u^2t^2 - 8u^3t + 792u^4) s^4 + 2u(31t^4 - 8ut^3 + 177u^2t^2 - 8u^3t + 660u^4) s^3 + 2u^2(57t^4 - 8u^3t^3 + 183u^2t^2 + 93u^3t \\
& + 374u^4) s^2 + u^3(62t^4 + 72ut^3 + 321u^2t^2 + 238u^3t + 264u^4) s + 44u^4(t^2 + ut + u^2)^2 H(0, z) \Big\} / (9st(s+t)^4u(s+u)^4(t+u)^4)
\end{aligned}$$

$$\mathcal{A}_{2;C_F n_f}^{(2)} = - \left\{ 8(s^4 + 2s^3(t+u) + 3s^2(t^2 + u^2) + 2s(t^3 + u^3) + (t^2 + tu + u^2)^2) \right\} / (stu)$$

$$\begin{aligned}
\mathcal{A}_{2;n_f}^{(2)} = & \left\{ -18u(s+u)^4(t+u)^4(s^2-ts+t^2+u^2)H(1,0,y)(s+t)^5 + 6(t+u)^4(2s^8+4(t+3u)s^7+2(3t^2+5ut+17u^2)s^6 \right. \\
& + (4t^3+15ut^2+6u^2t+60u^3)s^5 + 2(t^4+12u^2t^2-2u^3t+36u^4)s^4 + 2u(t^4-2ut^3+15u^2t^2-2u^3t+30u^4)s^3 + 2u^2(3t^4-2ut^3 \\
& + 12u^2t^2+3u^3t+17u^4)s^2 + (12u^7+10tu^6+15t^2u^5+2t^4u^3)s + 2u^4(t^2+ut+u^2)^2 H(0,z)(s+t)^4 - 18tu(s+u)^4(t+u)^4(t^2 \\
& + u^2)H(0,y)H(0,z)(s+t)^4 - 6(s+u)^4(2(t^4+ut^3+3u^2t^2+u^3t+u^4)s^4 + 4(t^5-u^2t^3-u^3t^2+u^5)s^3 + 3(t+u)^2(2t^4+ut^3 \\
& + 4u^2t^2+u^3t+2u^4)s^2 + 2(t+u)^3(2t^4-ut^3-u^3t+2u^4)s + 2(t+u)^4(t^2+ut+u^2)^2 H(1,z)(s+t)^4 + 18su(s+u)^4(t+u)^4(s^2 \\
& + u^2)H(0,y)H(1,z)(s+t)^4 - 6(s+u)^4(2(t^4+ut^3+3u^2t^2+u^3t+u^4)s^4 + 4(t^5-u^2t^3-u^3t^2+u^5)s^3 + 3(t+u)^2(2t^4 \\
& + ut^3+4u^2t^2+u^3t+2u^4)s^2 + 2(t+u)^3(2t^4-ut^3-u^3t+2u^4)s + 2(t+u)^4(t^2+ut+u^2)^2 H(2,y)(s+t)^4 \\
& + 18st(s^2+t^2)(s+u)^4(t+u)^4 H(0,z)H(2,y)(s+t)^4 - 18s(s+u)^4(t+u)^5(s^2+t^2+u^2-t)H(1,z)H(3,y)(s+t)^4 \\
& - 18su(s+u)^4(t+u)^4(s^2+u^2)H(0,1,z)(s+t)^4 + 18su(s+u)^4(t+u)^4(s^2+u^2)H(0,2,y)(s+t)^4 - 18tu(s+u)^4(t+u)^4(t^2 \\
& + u^2)H(1,0,z)(s+t)^4 + 18su(s+u)^4(t+u)^4(s^2+u^2)H(2,0,y)(s+t)^4 - 18s(s+u)^4(t+u)^5(s^2+t^2+u^2-t)H(3,2,y)(s+t)^4 \\
& + 6(s+u)(t+u)(5(t+u)^3s^{10} + 6(4t^4+15ut^3+23u^2t^2+15u^3t+4u^4)s^9 + (55t^5+227ut^4+437u^2t^3+437u^3t^2+227u^4t+55u^5)s^8 \\
& + (80t^6+350ut^5+731u^2t^4+940u^3t^3+731u^4t^2+350u^5t+80u^6)s^7 + (80t^7+396ut^6+852u^2t^5+1211u^3t^4+1211u^4t^3+852u^5t^2 \\
& + 396u^6t+80u^7)s^6 + (55t^8+350ut^7+852u^2t^6+1252u^3t^5+1408u^4t^4+1252u^5t^3+852u^6t^2+350u^7t+55u^8)s^5 + (24t^9+227ut^8 \\
& + 731u^2t^7+1211u^3t^6+1408u^4t^5+1408u^5t^4+1211u^6t^3+731u^7t^2+227u^8t+24u^9)s^4 + (5t^{10}+90u^9t^9+437u^2t^8+940u^3t^7 \\
& + 1211u^4t^6+1252u^5t^5+1211u^6t^4+940u^7t^3+437u^8t^2+90u^9t+5u^{10})s^3 + tu(15t^9+138ut^8+437u^2t^7+731u^3t^6+852u^4t^5 \\
& + 852u^5t^4+731u^6t^3+437u^7t^2+138u^8t+15u^9)s^2 + t^2u^2(t+u)^2(15t^6+60ut^5+92u^2t^4+106u^3t^3+92u^4t^2+60u^5t+15u^6)s \\
& + t^3u^3(t+u)^3(5t^4+9u^3t^3+13u^2t^2+9u^3t+5u^4)(s+t) + 6(s+u)^4(t+u)^4(2s^8+4(3t+u)s^7+2(17t^2+5ut+3u^2)s^6 + (60t^3 \\
& + 6u^2t^2+15u^2t+4u^3)s^5 + 2(36t^4-2ut^3+12u^2t^2+u^4)s^4 + 2t(30t^4-2ut^3+15u^2t^2-2u^3t+u^4)s^3 + 2t^2(17t^4+3ut^3 \\
& + 12u^2t^2-2u^3t+3u^4)s^2 + (12t^7+10u^6t^6+15u^2t^5+2u^4t^3)s + 2t^4(t^2+ut+u^2)^2 H(0,y) \left. \right\} / (9st(s+t)^4u(s+u)^4(t+u)^4)
\end{aligned}$$

$$\mathcal{A}_{3;C_A}^{(2)} = \left\{ 49s^4 + 98s^3(t+u) + 147s^2(t^2+u^2) + 98s(t^3+u^3) + 49t^4 - 450t^3u + 165t^2u^2 - 450tu^3 + 49u^4 \right\} / (5stu)$$

$$\mathcal{A}_{3;C_A n_f}^{(2)} = \left\{ 353t^2 - 588tu + 353u^2 \right\} / (5s)$$

$$\mathcal{A}_{3;C_F n_f}^{(2)} = -18 \left\{ t^2 + u^2 \right\} / (s)$$

$$\mathcal{A}_{3;n_f}^{(2)} = 0$$

$$\begin{aligned}
\mathcal{A}_{4;C_A}^{(2)} = & \left\{ 9s^2t^2u^2(231s^{16} + 1896(t+u)s^{15} + 6(1205t^2 + 2582u^2 + 1205u^2)s^{14} + 2(8485t^3 + 28497ut^2 + 28497u^2t + 8485u^3)s^{13} \right. \\
& + (27247t^4 + 132002ut^3 + 187458u^2t^2 + 132002u^3t + 27247u^4)s^{12} + 12(2609t^5 + 18137ut^4 + 32471u^2t^3 + 32471u^3t^2 + 18137u^4t \\
& + 2609u^5)s^{11} + (26071t^6 + 265278u^5t^5 + 584223u^2t^4 + 758272u^3t^3 + 584223u^4t^2 + 265278u^5t + 26071u^6)s^{10} + 2(7765t^7 + 118994ut^6 \\
& + 329001u^2t^5 + 544812u^3t^4 + 544812u^4t^3 + 329001u^5t^2 + 118994u^6t + 7765u^7)s^9 + 3(2110t^8 + 50618ut^7 + 186907u^2t^6 + 405032u^3t^5 \\
& + 468376u^4t^4 + 405032u^5t^3 + 186907u^6t^2 + 50618u^7t + 2110u^8)s^8 + 4(398t^9 + 16089ut^8 + 86178u^2t^7 + 272710u^3t^6 + 333261u^4t^5 \\
& + 333261u^5t^4 + 272710u^6t^3 + 86178u^7t^2 + 16089u^8t + 398u^9)s^7 + (187t^{10} + 16046ut^9 + 137715u^2t^8 + 724384u^3t^7 + 1065452u^4t^6 \\
& + 947616u^5t^5 + 1065452u^6t^4 + 724384u^7t^3 + 137715u^8t^2 + 16046u^9t + 187u^{10})s^6 + 6tu(299t^9 + 5160ut^8 + 51597u^2t^7 + 106788u^3t^6 \\
& + 101934u^4t^5 + 101934u^5t^4 + 106788u^6t^3 + 51597u^7t^2 + 5160u^8t + 299u^9)s^5 + t^2u^2(2973t^8 + 74726ut^7 + 236013u^2t^6 + 329784u^3t^5 \\
& + 314484u^4t^4 + 329784u^5t^3 + 236013u^6t^2 + 74726u^7t + 2973u^8)s^4 + 12t^3u^3(651t^7 + 3762ut^6 + 9502u^2t^5 + 11138u^3t^4 + 11138u^4t^3 \\
& + 9502u^5t^2 + 3762u^6t + 651u^7)s^3 + 3t^4u^4(1027t^6 + 7446ut^5 + 12323u^2t^4 + 11392u^3t^3 + 12323u^4t^2 + 7446u^5t + 1027u^6)s^2 \\
& + 6t^5u^5(315t^5 + 904ut^4 + 837u^2t^3 + 837u^3t^2 + 904u^4t + 315u^5)s + t^6u^6(215t^4 + 250ut^3 + 357u^2t^2 + 250u^3t + 215u^4)(t+u)^6 \\
& - 108s^2t^2(s+t)^6u^2(s+u)^6(s^4+2(t+u)s^3+3(t^2+u^2)s^2+2(t^3+u^3)s+t^4+u^4-12tu^3+18t^2u^2-24t^3u)H(0,y)(t+u)^6 \\
& - 108s^2t^2(s+t)^6u^2(s+u)^6(s^4+2(t+u)s^3+3(t^2+u^2)s^2+2(t^3+u^3)s+t^4+u^4-24tu^3+18t^2u^2-12t^3u)H(0,z)(t+u)^6 \\
& + 216s^2t^2(s+t)^6u^3(s+u)^6(2s^3-6us^2+10u^2s+3t(2t^2-3ut+4u^2))H(1,y)(t+u)^6 + 108s^2t^2(s+t)^6u^2(s+u)^6(s^4+2(t-u)s^3 \\
& + 3(t^2+5u^2)s^2+2(t^3-9u^3)s+t^4+u^4+18tu^3-9t^2u^2+30t^3u)H(1,z)(t+u)^6 + 108s^2t^2(s+t)^6u^2(s+u)^6(s^4-2(t+u)s^3 \\
& + 15(t^2+u^2)s^2-18(t^3+u^3)s+t^4+u^4+6tu^3+9t^2u^2+6t^3u)H(2,y)(t+u)^6 \left. \right\} / (27s^3t^3u^3(s+t)^6(s+u)^6(t+u)^6)
\end{aligned}$$

$$\begin{aligned}
\mathcal{A}_{4;CAn_f}^{(2)} = & \left\{ 9s^2t^2u^2(54s^{16} + 420(t+u)s^{15} + 24(64t^2 + 93ut + 64u^2)s^{14} + (3520t^3 + 6099ut^2 + 6099u^2t + 3520u^3)s^{13} \right. \\
& + 2(2821t^4 + 4943ut^3 + 9330u^2t^2 + 4943u^3t + 2821u^4)s^{12} + 6(1106t^5 + 1697ut^4 + 6163u^2t^3 + 6163u^3t^2 + 1697u^4t + 1106u^5)s^{11} \\
& + (5810t^6 + 7365ut^5 + 65076u^2t^4 + 38726u^3t^3 + 65076u^4t^2 + 7365u^5t + 5810u^6)s^{10} + (3736t^7 + 3503u^6t + 105864u^2t^5 + 17977u^3t^4 \\
& + 17977u^4t^3 + 105864u^5t^2 + 3503u^6t + 3736u^7)s^9 + 3(560t^8 + 208ut^7 + 38974u^2t^6 + 8059u^3t^5 - 15308u^4t^4 + 8059u^5t^3 + 38974u^6t^2 \\
& + 208u^7t + 560u^8)s^8 + (472t^9 + 60ut^8 + 81318u^2t^7 - 8215u^3t^6 + 18453u^4t^5 + 18453u^5t^4 - 8215u^6t^3 + 81318u^7t^2 + 60u^8t \\
& + 472u^9)s^7 + (62t^{10} + 229ut^9 + 37632u^2t^8 - 50045u^3t^7 + 25292u^4t^6 + 177060u^5t^5 + 25292u^6t^4 - 50045u^7t^3 + 37632u^8t^2 \\
& + 229u^9t + 62u^{10})s^6 + 3tu(24t^9 + 3679ut^8 - 12820u^2t^7 + 195u^3t^6 + 50191u^4t^5 + 50191u^5t^4 + 195u^6t^3 - 12820u^7t^2 + 3679u^8t \\
& + 24u^9)s^5 + 2t^2u^2(735t^8 - 6322ut^7 + 3033u^2t^6 + 30537u^3t^5 + 41982u^4t^4 + 30537u^5t^3 + 3033u^6t^2 - 6322u^7t + 735u^8)s^4 \\
& + t^3u^3(-1700t^7 + 5703ut^6 + 17862u^2t^5 + 21167u^3t^4 + 21167u^4t^3 + 17862u^5t^2 + 5703u^6t - 1700u^7)s^3 + 12t^4u^4(109t^6 \\
& + 190ut^5 + 297u^2t^4 + 423u^3t^3 + 297u^4t^2 + 190u^5t + 109u^6)s^2 - 6t^5u^5(12t^5 - 24ut^4 - 209u^2t^3 - 209u^3t^2 - 24u^4t + 12u^5)s \\
& + t^6u^6(20t^4 + 131ut^3 + 174u^2t^2 + 131u^3t + 20u^4)(t+u)^6 - 162s^2t^3(s+t)^6u^3(s+u)^6(8t^2 - 21ut \\
& + 17u^2)H(0,y)(t+u)^6 - 162s^2t^3(s+t)^6u^3(s+u)^6(17t^2 - 21ut + 8u^2)H(0,z)(t+u)^6 - 54s^2t^2(s+t)^6u^3(s+u)^6(41s^3 \\
& - 42us^2 + 5u^2s + t(50t^2 - 63ut + 23u^2))H(1,y)(t+u)^6 + 54s^2t^2(s+t)^6u^3(s+u)^6(41s^3 - 42us^2 \\
& + 5u^2s + t(-25t^2 + 63ut - 52u^2))H(1,z)(t+u)^6 + 54s^2t^2(s+t)^6u^2(s+u)^6(41(t+u)s^3 - 42(t^2 \\
& + u^2)s^2 + 5(t^3 + u^3)s - 2tu(t^2 + u^2))H(2,y)(t+u)^6 \left. \right\} / (27s^3t^3u^3(s+t)^6(s+u)^6(t+u)^6)
\end{aligned}$$

$$\begin{aligned}
\mathcal{A}_{4;CFn_f}^{(2)} = & \left\{ 432s^3t^2(s+t)^6u^2(s+u)^6(-3s^2 + t^2 + u^2 - tu)H(2,y)(t+u)^7 - 18s^2t^2u^2(48s^{16} + 384(t+u)s^{15} + 12(120t^2 + 227ut \right. \\
& + 120u^2)s^{14} + (3360t^3 + 9087ut^2 + 9087u^2t + 3360u^3)s^{13} + 3(1808t^4 + 6521ut^3 + 8604u^2t^2 + 6521u^3t + 1808u^4)s^{12} \\
& + (6336t^5 + 30735ut^4 + 47598u^2t^3 + 47598u^3t^2 + 30735u^4t + 6336u^5)s^{11} + (5424t^6 + 36543ut^5 + 67614u^2t^4 + 73464u^3t^3 \\
& + 67614u^4t^2 + 36543u^5t + 5424u^6)s^{10} + (3360t^7 + 32505ut^6 + 77922u^2t^5 + 91295u^3t^4 + 91295u^4t^3 + 77922u^5t^2 + 32505u^6t \\
& + 3360u^7)s^9 + 3(480t^8 + 6939ut^7 + 23404u^2t^6 + 34497u^3t^5 + 31012u^4t^4 + 34497u^5t^3 + 23404u^6t^2 + 6939u^7t + 480u^8)s^8 \\
& + 3(128t^9 + 2999ut^8 + 15226u^2t^7 + 33508u^3t^6 + 30137u^4t^5 + 30137u^5t^4 + 33508u^6t^3 + 15226u^7t^2 + 2999u^8t + 128u^9)s^7 \\
& + (48t^{10} + 2337ut^9 + 19494u^2t^8 + 70630u^3t^7 + 86678u^4t^6 + 65250u^5t^5 + 86678u^6t^4 + 70630u^7t^3 + 19494u^8t^2 + 2337u^9t \\
& + 48u^{10})s^6 + 3tu(92t^9 + 1601ut^8 + 10417u^2t^7 + 20343u^3t^6 + 17708u^4t^5 + 17708u^5t^4 + 20343u^6t^3 + 10417u^7t^2 + 1601u^8t \\
& + 92u^9)s^5 + 3t^2u^2(172t^8 + 2556ut^7 + 8524u^2t^6 + 11797u^3t^5 + 10692u^4t^4 + 11797u^5t^3 + 8524u^6t^2 + 2556u^7t + 172u^8)s^4 \\
& + t^3u^3(788t^7 + 5538ut^6 + 14103u^2t^5 + 16252u^3t^4 + 16252u^4t^3 + 14103u^5t^2 + 5538u^6t + 788u^7)s^3 + 3t^4u^4(148t^6 \\
& + 959ut^5 + 1726u^2t^4 + 1748u^3t^3 + 1726u^4t^2 + 959u^5t + 148u^6)s^2 + 3t^5u^5(72t^5 + 265ut^4 + 347u^2t^3 + 347u^3t^2 + 265u^4t \\
& + 72u^5)s + 2t^6u^6(16t^4 + 39ut^3 + 54u^2t^2 + 39u^3t + 16u^4)(t+u)^6 + 108s^2t^3(s+t)^6u^3(s+u)^6(t^2 + 13u^2)H(0,y)(t+u)^6 \\
& + 108s^2t^3(s+t)^6u^3(s+u)^6(13t^2 + u^2)H(0,z)(t+u)^6 + 108s^2t^2(s+t)^6u^3(s+u)^6(12s^3 - 4u^2s + 13t^3 + tu^2)H(1,y)(t+u)^6 \\
& - 108s^2t^2(s+t)^6u^3(s+u)^6(12s^3 - 4u^2s - t(t^2 + 13u^2))H(1,z)(t+u)^6 \left. \right\} / (27s^3t^3u^3(s+t)^6(s+u)^6(t+u)^6)
\end{aligned}$$

$$\mathcal{A}_{4;n_f}^{(2)} = 0$$

$$\begin{aligned}
\mathcal{A}_{5;C_A}^{(2)} = & \left\{ 9s^2t^2(s+t)^2u^2(55s^{14} + (330t + 416u)s^{13} + (935t^2 + 1844ut + 1500u^2)s^{12} + 30(55t^3 + 135ut^2 + 167u^2t + 115u^3)s^{11} \right. \\
& + (1980t^4 + 5670ut^3 + 8826u^2t^2 + 8462u^3t + 5643u^4)s^{10} + 2(825t^5 + 2487ut^4 + 6495u^2t^3 + 3799u^3t^2 + 5061u^4t + 3426u^5)s^9 \\
& + (935t^6 + 2568ut^5 + 15141u^2t^4 + 4070u^3t^3 - 1902u^4t^2 + 9678u^5t + 6231u^6)s^8 + 2(165t^7 + 443ut^6 + 6261u^2t^5 - 139u^3t^4 - 8575u^4t^3 \\
& - 4065u^5t^2 + 3881u^6t + 2085u^7)s^7 + (55t^8 + 334ut^7 + 7728u^2t^6 - 6262u^3t^5 - 17396u^4t^4 - 22194u^5t^3 - 7172u^6t^2 + 5130u^7t \\
& + 1950u^8)s^6 + 2u(45t^8 + 1695ut^7 - 3483u^2t^6 - 4305u^3t^5 - 4851u^4t^4 - 8249u^5t^3 - 1455u^6t^2 + 1362u^7t + 284u^8)s^5 + u^2(717t^8 \\
& - 2782ut^7 - 1182u^2t^6 + 5322u^3t^5 - 4938u^4t^4 - 7502u^5t^3 + 711u^6t^2 + 998u^7t + 77u^8)s^4 - 2tu^3(158t^7 - 735ut^6 - 2541u^2t^5 \\
& - 2255u^3t^4 + 577u^4t^3 + 150u^5t^2 - 512u^6t - 82u^7)s^3 + t^2u^4(717t^6 + 1098ut^5 + 2632u^2t^4 + 2622u^3t^3 + 1308u^4t^2 + 852u^5t + 234u^6)s^2 \\
& + 2t^3u^5(45t^5 + 157ut^4 + 619u^2t^3 + 516u^3t^2 + 340u^4t + 102u^5)s + t^4u^6(55t^4 + 134ut^3 + 207u^2t^2 + 134u^3t + 105u^4)H(0,y)(t+u)^6 \\
& \left. \right\}
\end{aligned}$$

$$\begin{aligned}
& + 9s^2t^2u^2(s+u)^2(55s^{14} + (416t + 330u)s^{13} + (1500t^2 + 1844ut + 935u^2)s^{12} + 30(115t^3 + 167ut^2 + 135u^2t + 55u^3)s^{11} + (5643t^4 \\
& + 8462ut^3 + 8826u^2t^2 + 5670u^3t + 1980u^4)s^{10} + 2(3426t^5 + 5061ut^4 + 3799u^2t^3 + 6495u^3t^2 + 2487u^4t + 825u^5)s^9 + (6231t^6 \\
& + 9678ut^5 - 1902u^2t^4 + 4070u^3t^3 + 15141u^4t^2 + 2568u^5t + 935u^6)s^8 + 2(2085t^7 + 3881ut^6 - 4065u^2t^5 - 8575u^3t^4 - 139u^4t^3 \\
& + 6261u^5t^2 + 443u^6t + 165u^7)s^7 + (1950t^8 + 5130ut^7 - 7172u^2t^6 - 22194u^3t^5 - 17396u^4t^4 - 6262u^5t^3 + 7728u^6t^2 + 334u^7t \\
& + 55u^8)s^6 + 2t(284t^8 + 1362ut^7 - 1455u^2t^6 - 8249u^3t^5 - 4851u^4t^4 - 4305u^5t^3 - 3483u^6t^2 + 1695u^7t + 45u^8)s^5 + t^2(77t^8 \\
& + 998ut^7 + 711u^2t^6 - 7502u^3t^5 - 4938u^4t^4 + 5322u^5t^3 - 1182u^6t^2 - 2782u^7t + 717u^8)s^4 + 2t^3u(82t^7 + 512ut^6 - 150u^2t^5 - 577u^3t^4 \\
& + 2255u^4t^3 + 2541u^5t^2 + 735u^6t - 158u^7)s^3 + t^4u^2(234t^6 + 852ut^5 + 1308u^2t^4 + 2622u^3t^3 + 2632u^4t^2 + 1098u^5t + 717u^6)s^2 \\
& + 2t^5u^3(102t^5 + 340ut^4 + 516u^2t^3 + 619u^3t^2 + 157u^4t + 45u^5)s + t^6u^4(105t^4 + 134ut^3 + 207u^2t^2 + 134u^3t + 55u^4)H(0, z)(t+u)^6 \\
& + 108s^2t^2(s+t)^6u^2(s+u)^6(3s^4 + 6(t+u)s^3 + 9(t^2+u^2)s^2 + 6(t^3+u^3)s + 3t^4 + 3u^4 - 4tu^3 - 6t^2u^2 - 4t^3u)H(0, y)H(0, z)(t+u)^6 \\
& - 18s^2t^2(s+t)^2u^2(s+u)^6(3s^8 + 2(51t+u)s^7 + (486t^2 + 200ut + 30u^2)s^6 + 6(179t^3 + 130ut^2 + 96u^2t + 7u^3)s^5 + 2(687t^4 + 677ut^3 \\
& + 945u^2t^2 + 265u^3t + 29u^4)s^4 + 2t(537t^4 + 677ut^3 + 1344u^2t^2 + 658u^3t + 170u^4)s^3 + 2t^2(243t^4 + 390ut^3 + 945u^2t^2 + 658u^3t \\
& + 270u^4)s^2 + 2t^3(51t^4 + 100ut^3 + 288u^2t^2 + 265u^3t + 170u^4)s + t^4(3t^4 + 2ut^3 + 30u^2t^2 + 42u^3t + 58u^4)H(1, y)(t+u)^6 \\
& - 216s^2t^2(s+t)^6u^3(s+u)^6(2s^3 - 3us^2 + 4u^2s + t(2t^2 - 3ut + 4u^2))H(0, z)H(1, y)(t+u)^6 - 108s^2t^2(s+t)^6u^2(s+u)^6(3s^4 \\
& + (6t - 8u)s^3 + (9t^2 + 6u^2)s^2 + (6t^3 - 4u^3)s + 3t^4 + 3u^4 + 12tu^3 + 6t^2u^2 + 16t^3u)H(0, y)H(1, z)(t+u)^6 \\
& - 1296s^2t^2(s+t)^6u^3(s+u)^6(s^3 - us^2 + u^2s + t(t^2 - ut + u^2))H(1, y)H(1, z)(t+u)^6 - 108s^2t^2(s+t)^6u^2(s+u)^6(3s^4 + (2u - 8t)s^3 \\
& + 3(2t^2 + 5u^2)s^2 - 2(2t^3 + u^3)s + 3t^4 + 3u^4 + 8tu^3 + 12t^2u^2 + 8t^3u)H(0, z)H(2, y)(t+u)^6 - 108s^2t^2(s+t)^6u^2(s+u)^6(8s^4 \\
& + (4t - 2u)s^3 + 9(2t^2 + 3u^2)s^2 - 2u^3s + 8t^4 + 8u^4 + 18tu^3 + 27t^2u^2 + 18t^3u)H(1, z)H(2, y)(t+u)^6 - 108s^2t^2(s+t)^6u^2(s+u)^6(2s^4 \\
& + 10(t+u)s^3 - 3(t^2 + u^2)s^2 + 6(t^3 + u^3)s + 2(t^2 + ut + u^2)^2)H(1, z)H(3, y)(t+u)^6 - 108s^2t^3(s+t)^6u^3(s+u)^6(6t^2 - 9ut \\
& + 2u^2)H(0, 0, y)(t+u)^6 - 108s^2t^3(s+t)^6u^3(s+u)^6(2t^2 - 9ut + 6u^2)H(0, 0, z)(t+u)^6 + 432s^2t^2(s+t)^6u^2(s+u)^6(2s^4 \\
& + 2(2t+u)s^3 + 3(2t^2 + u^2)s^2 + 2(2t^3 + u^3)s + 2t^4 + 2u^4 + 2tu^3 + 3t^2u^2 + 2t^3u)H(0, 1, y)(t+u)^6 + 108s^2t^2(s+t)^6u^2(s+u)^6(3s^4 \\
& + (6t - 2u)s^3 + 3(3t^2 + 5u^2)s^2 + 2(3t^3 + u^3)s + 3t^4 + 3u^4 - 14tu^3 + 9t^2u^2 - 14t^3u)H(0, 1, z)(t+u)^6 - 108s^2t^2(s+t)^6u^2(s+u)^6(3s^4 \\
& + 8(t-u)s^3 + 6(2t^2 + u^2)s^2 + (8t^3 - 4u^3)s + 3(t^4 + 6ut^3 - u^2t^2 + 6u^3t + u^4))H(0, 2, y)(t+u)^6 + 108s^2t^2(s+t)^6u^2(s+u)^6(6s^4 \\
& + 2(6t-u)s^3 + 3(6t^2 + 5u^2)s^2 + 2(6t^3 + u^3)s + 6t^4 + 6u^4 + 6tu^3 + 9t^2u^2 + 6t^3u)H(1, 0, y)(t+u)^6 + 108s^2t^2(s+t)^6u^2(s+u)^6(3s^4 \\
& + 2(3t+5u)s^3 + 3(3t^2 + u^2)s^2 + 2(3t^3 + 7u^3)s + 3t^4 + 3u^4 - 2tu^3 - 3t^2u^2 - 2t^3u)H(1, 0, z)(t+u)^6 + 216s^2t^2(s+t)^6u^2(s+u)^6(4s^4 \\
& + 8(t+u)s^3 + 3(4t^2 + u^2)s^2 + (8t^3 + 6u^3)s + 4t^4 + 4u^4 + 6tu^3 + 3t^2u^2 + 8t^3u)H(1, 1, y)(t+u)^6 + 108s^2t^2(s+t)^6u^3(s+u)^6(18s^3 \\
& - 3us^2 + 18u^2s - t(18t^2 + 9ut + 14u^2))H(1, 1, z)(t+u)^6 - 1296s^2t^2(s+t)^6u^3(s+u)^6(s^3 - us^2 + u^2s + t(t^2 - ut \\
& + u^2))H(1, 2, y)(t+u)^6 - 108s^2t^2(s+t)^6u^2(s+u)^6(3s^4 + 2(t-4u)s^3 + 3(5t^2 + 2u^2)s^2 - 2(t^3 + 2u^3)s + 3t^4 + 3u^4 + 8tu^3 \\
& + 12t^2u^2 + 8t^3u)H(2, 0, y)(t+u)^6 - 108s^2t^2(s+t)^6u^3(s+u)^6(6s^3 - 9us^2 + 2u^2s + t(2t^2 + 3ut + 2u^2))H(2, 1, y)(t+u)^6 \\
& - 108s^2t^2(s+t)^6u^2(s+u)^6(8s^4 - 2(t+u)s^3 + 27(t^2 + u^2)s^2 - 2(t^3 + u^3)s + 8(t^2 + ut + u^2)^2)H(2, 2, y)(t+u)^6 \\
& - 108s^2t^2(s+t)^6u^2(s+u)^6(2s^4 + 10(t+u)s^3 - 3(t^2 + u^2)s^2 + 6(t^3 + u^3)s + 2(t^2 + ut + u^2)^2)H(3, 2, y)(t+u)^6 \\
& + 9t^2(s+t)u^2(s+u)(366(t+u)^6s^{16} + 12(213t^7 + 1475ut^6 + 4463u^2t^5 + 7365u^3t^4 + 7365u^4t^3 + 4463u^5t^2 + 1475u^6t + 213u^7)s^{15} \\
& + 2(t+u)^2(4186t^6 + 23989ut^5 + 61240u^2t^4 + 77078u^3t^3 + 61240u^4t^2 + 23989u^5t + 4186u^6)s^{14} + 2(8526t^9 + 72111ut^8 + 283103u^2t^7 \\
& + 646677u^3t^6 + 948359u^4t^5 + 948359u^5t^4 + 646677u^6t^3 + 283103u^7t^2 + 72111u^8t + 8526u^9)s^{13} + (t+u)^2(23886t^8 + 172264ut^7 \\
& + 582649u^2t^6 + 1131132u^3t^5 + 1344162u^4t^4 + 1131132u^5t^3 + 582649u^6t^2 + 172264u^7t + 23886u^8)s^{12} + (23866t^{11} + 243086u^2t^{10} \\
& + 1157425u^2t^9 + 3382695u^3t^8 + 6575795u^4t^7 + 8973837u^5t^6 + 8973837u^6t^5 + 6575795u^7t^4 + 3382695u^8t^3 + 1157425u^9t^2 \\
& + 243086u^{10}t + 23866u^{11})s^{11} + (t+u)^2(17016t^{10} + 164440ut^9 + 724400u^2t^8 + 1917401u^3t^7 + 3236864u^4t^6 + 3710558u^5t^5 \\
& + 3236864u^6t^4 + 1917401u^7t^3 + 724400u^8t^2 + 164440u^9t + 17016u^{10})s^{10} + 2(4176t^{13} + 58901ut^{12} + 382615u^2t^{11} + 1458232u^3t^{10} \\
& + 3634444u^4t^9 + 6299163u^5t^8 + 8074581u^6t^7 + 8074581u^7t^6 + 6299163u^8t^5 + 3634444u^9t^4 + 1458232u^{10}t^3 + 382615u^{11}t^2 \\
& + 58901u^{12}t + 4176u^{13})s^9 + (t+u)^2(2552t^{12} + 42616ut^{11} + 321337u^2t^{10} + 1192960u^3t^9 + 2636700u^4t^8 + 3851544u^5t^7 \\
& + 4187542u^6t^6 + 3851544u^7t^5 + 2636700u^8t^4 + 1192960u^9t^3 + 321337u^{10}t^2 + 42616u^{11}t + 2552u^{12})s^8 + (366t^{15} + 11590ut^{14} \\
& + 150117u^2t^{13} + 868535u^3t^{12} + 2906129u^4t^{11} + 6451075u^5t^{10} + 10280514u^6t^9 + 12609962u^7t^8 + 12609962u^8t^7 + 10280514u^9t^6 \\
\end{aligned}$$

$$\begin{aligned}
& + 6451075u^{10}t^5 + 2906129u^{11}t^4 + 868535u^{12}t^3 + 150117u^{13}t^2 + 11590u^{14}t + 366u^{15})s^7 + tu(t+u)^2(1254t^{12} + 30458ut^{11} \\
& + 192025u^2t^{10} + 634366u^3t^9 + 1369170u^4t^8 + 2072140u^5t^7 + 2324670u^6t^6 + 2072140u^7t^5 + 1369170u^8t^4 + 634366u^9t^3 + 192025u^{10}t^2 \\
& + 30458u^{11}t + 1254u^{12})s^6 + 2t^2u^2(1605t^{13} + 19222ut^{12} + 110551u^2t^{11} + 398318u^3t^{10} + 989437u^4t^9 + 1764628u^5t^8 + 2329703u^6t^7 \\
& + 2329703u^7t^6 + 1764628u^8t^5 + 989437u^9t^4 + 398318u^{10}t^3 + 110551u^{11}t^2 + 19222u^{12}t + 1605u^{13})s^5 + t^3u^3(t+u)^2(1678t^{10} \\
& + 19862ut^9 + 93582u^2t^8 + 253073u^3t^7 + 439352u^4t^6 + 520162u^5t^5 + 439352u^6t^4 + 253073u^7t^3 + 93582u^8t^2 + 19862u^9t + 1678u^{10})s^4 \\
& + t^4u^4(t+u)^3(1260t^8 + 9096ut^7 + 30583u^2t^6 + 61244u^3t^5 + 75426u^4t^4 + 61244u^5t^3 + 30583u^6t^2 + 9096u^7t + 1260u^8)s^3 \\
& + t^5u^5(t+u)^4(324t^6 + 2168ut^5 + 6197u^2t^4 + 8622u^3t^3 + 6197u^4t^2 + 2168u^5t + 324u^6)s^2 + 10t^6u^6(t+u)^7(14t^2 + 27ut + 14u^2)s \\
& + 40t^7u^7(t+u)^6(t^2 + ut + u^2) + 9s^2t^2u^2(3(11t^6 + 130u^5t^5 + 141u^2t^4 + 604u^3t^3 + 141u^4t^2 + 130u^5t + 11u^6)s^{16} + 8(45t^7 + 521ut^6 \\
& + 1056u^2t^5 + 2598u^3t^4 + 2488u^4t^3 + 858u^5t^2 + 411u^6t + 23u^7)s^{15} + 6(285t^8 + 3120u^7t^7 + 8470u^2t^6 + 17852u^3t^5 + 25104u^4t^4 \\
& + 15024u^5t^3 + 5642u^6t^2 + 1908u^7t + 83u^8)s^{14} + 2(2375t^9 + 24561ut^8 + 80646u^2t^7 + 164370u^3t^6 + 268500u^4t^5 + 242676u^5t^4 \\
& + 112746u^6t^3 + 43806u^7t^2 + 11685u^8t + 539u^9)s^{13} + (8669t^{10} + 85044ut^9 + 320811u^2t^8 + 677420u^3t^7 + 1161930u^4t^6 + 1394268u^5t^5 \\
& + 895510u^6t^4 + 373044u^7t^3 + 149697u^8t^2 + 34384u^9t + 2343u^{10})s^{12} + 12(915t^{11} + 8573u^10 + 35593u^2t^9 + 81037u^3t^8 + 140831u^4t^7 \\
& + 205671u^5t^6 + 184091u^6t^5 + 94279u^7t^4 + 41772u^8t^3 + 16990u^9t^2 + 3718u^{10}t + 370u^{11})s^{11} + (9845t^{12} + 88872ut^{11} + 394182u^2t^{10} \\
& + 982076u^3t^9 + 1680477u^4t^8 + 2723040u^5t^7 + 3377880u^6t^6 + 2469456u^7t^5 + 1323771u^8t^4 + 704312u^9t^3 + 264210u^{10}t^2 + 55188u^{11}t \\
& + 6179u^{12})s^{10} + 2(3095t^{13} + 27024ut^{12} + 127632u^2t^{11} + 352506u^3t^{10} + 563960u^4t^9 + 824355u^5t^8 + 1409056u^6t^7 + 1665520u^7t^6 \\
& + 1351875u^8t^5 + 966790u^9t^4 + 514400u^{10}t^3 + 159702u^{11}t^2 + 28798u^{12}t + 2919u^{13})s^9 + 3(870t^{14} + 7314u^{13} + 37677u^2t^{12} \\
& + 112780u^3t^{11} + 143003u^4t^{10} + 53282u^5t^9 + 249844u^6t^8 + 845260u^7t^7 + 1239890u^8t^6 + 1252614u^9t^5 + 905087u^{10}t^4 + 401760u^{11}t^3 \\
& + 101733u^{12}t^2 + 14670u^{13}t + 1176u^{14})s^8 + 4(166t^{15} + 1359ut^{14} + 8343u^2t^{13} + 18170u^3t^{12} - 29355u^4t^{11} - 193428u^5t^{10} \\
& - 186082u^6t^9 + 373479u^7t^8 + 1074360u^8t^7 + 1349559u^9t^6 + 1156713u^{10}t^5 + 673434u^{11}t^4 + 244731u^{12}t^3 + 51600u^{13}t^2 + 5604u^{14}t \\
& + 307u^{15})s^7 + (77t^{16} + 712ut^{15} + 7926u^2t^{14} - 22420u^3t^{13} - 310304u^4t^{12} - 964008u^5t^{11} - 1004190u^6t^{10} + 1290836u^7t^9 \\
& + 5018184u^8t^8 + 6920472u^9t^7 + 6102774u^{10}t^6 + 3900588u^{11}t^5 + 1764592u^{12}t^4 + 528392u^{13}t^3 + 92178u^{14}t^2 + 6772u^{15}t \\
& + 187u^{16})s^6 + 6tu(5t^{15} + 338ut^{14} - 3532u^2t^{13} - 33260u^3t^{12} - 97374u^4t^{11} - 95800u^5t^{10} + 181294u^6t^9 + 739773u^7t^8 \\
& + 1163599u^8t^7 + 1123652u^9t^6 + 758126u^{10}t^5 + 368632u^{11}t^4 + 127306u^{12}t^3 + 29970u^{13}t^2 + 4032u^{14}t + 151u^{15})s^5 + t^2u^2(327t^{14} \\
& - 6804ut^{13} - 59454u^2t^{12} - 167472u^3t^{11} - 99128u^4t^{10} + 699492u^5t^9 + 2552097u^6t^8 + 4572060u^7t^7 + 5195055u^8t^6 + 4069272u^9t^5 \\
& + 2242188u^{10}t^4 + 847572u^{11}t^3 + 212250u^{12}t^2 + 33688u^{13}t + 2793u^{14})s^4 + 4t^3u^3(-233t^{13} - 1616u^12 - 3051u^2t^{11} + 10663u^3t^{10} \\
& + 80192u^4t^9 + 249270u^5t^8 + 483611u^6t^7 + 633999u^7t^6 + 583800u^8t^5 + 382847u^9t^4 + 174178u^{10}t^3 + 51444u^{11}t^2 + 8727u^{12}t \\
& + 617u^{13})s^3 + 3t^4u^4(t+u)^2(109t^{10} + 662ut^9 + 4205u^2t^8 + 17972u^3t^7 + 46152u^4t^6 + 74668u^5t^5 + 76440u^6t^4 + 53188u^7t^3 \\
& + 24579u^8t^2 + 6934u^9t + 931u^{10})s^2 + 2t^5u^5(t+u)^3(15t^8 + 481ut^7 + 3156u^2t^6 + 8739u^3t^5 + 13780u^4t^4 + 12711u^5t^3 \\
& + 7500u^6t^2 + 2637u^7t + 453u^8)s + t^6u^6(t+u)^6(77t^4 + 270ut^3 + 477u^2t^2 + 350u^3t + 187u^4)H(1, z) + 9s^2t^2u^2(3(13t^6 \\
& + 142ut^5 + 171u^2t^4 + 644u^3t^3 + 171u^4t^2 + 142u^5t + 13u^6)s^{16} + 8(50t^7 + 578ut^6 + 1293u^2t^5 + 3103u^3t^4 + 3103u^4t^3 \\
& + 1293u^5t^2 + 578u^6t + 50u^7)s^{15} + 12(157t^8 + 1789ut^7 + 5420u^2t^6 + 12039u^3t^5 + 17342u^4t^4 + 12039u^5t^3 + 5420u^6t^2 + 1789u^7t \\
& + 157u^8)s^{14} + (5374t^9 + 59826ut^8 + 223092u^2t^7 + 513996u^3t^6 + 871536u^4t^5 + 871536u^5t^4 + 513996u^6t^3 + 223092u^7t^2 \\
& + 59826u^8t + 5374u^9)s^{13} + (10359t^{10} + 114484ut^9 + 503079u^2t^8 + 1279432u^3t^7 + 2390090u^4t^6 + 3044424u^5t^5 + 2390090u^6t^4 \\
& + 1279432u^7t^3 + 503079u^8t^2 + 114484u^9t + 10359u^{10})s^{12} + 12(1186t^{11} + 13429u^10 + 67778u^2t^9 + 197005u^3t^8 + 403359u^4t^7 \\
& + 605123u^5t^6 + 605123u^6t^5 + 403359u^7t^4 + 197005u^8t^3 + 67778u^9t^2 + 13429u^{10}t + 1186u^{11})s^{11} + (14195t^{12} + 171720ut^{11} \\
& + 991722u^2t^{10} + 3343932u^3t^9 + 7591317u^4t^8 + 12777132u^5t^7 + 15424700u^6t^6 + 12777132u^7t^5 + 7591317u^8t^4 + 3343932u^9t^3 \\
& + 991722u^{10}t^2 + 171720u^{11}t + 14195u^{12})s^{10} + 2(5067t^{13} + 68848u^12 + 464430u^2t^{11} + 1834210u^3t^{10} + 4687302u^4t^9 \\
& + 8645967u^5t^8 + 11943168u^6t^7 + 11943168u^7t^6 + 8645967u^8t^5 + 4687302u^9t^4 + 1834210u^{10}t^3 + 464430u^{11}t^2 + 68848u^{12}t \\
& + 5067u^{13})s^9 + 3(1638t^{14} + 26822ut^{13} + 219527u^2t^{12} + 1022692u^3t^{11} + 2994269u^4t^{10} + 6115342u^5t^9 + 9403374u^6t^8
\end{aligned}$$

$$\begin{aligned}
& + 10916304u^7 t^7 + 9403374u^8 t^6 + 6115342u^9 t^5 + 2994269u^{10} t^4 + 1022692u^{11} t^3 + 219527u^{12} t^2 + 26822u^{13} t + 1638u^{14} \Big) s^8 \\
& + 4 \left( 361 t^{15} + 8109ut^{14} + 85470u^2 t^{13} + 471328u^3 t^{12} + 1600674u^4 t^{11} + 3733632u^5 t^{10} + 6488383u^6 t^9 + 8627643u^7 t^8 + 8627643u^8 t^7 \right. \\
& + 6488383u^9 t^6 + 3733632u^{10} t^5 + 1600674u^{11} t^4 + 471328u^{12} t^3 + 85470u^{13} t^2 + 8109u^{14} t + 361u^{15} \Big) s^7 + \left( 193 t^{16} + 8108ut^{15} \right. \\
& + 123366u^2 t^{14} + 816896u^3 t^{13} + 3259172u^4 t^{12} + 8952972u^5 t^{11} + 18149594u^6 t^{10} + 27988696u^7 t^9 + 32478774u^8 t^8 + 27988696u^9 t^7 \\
& + 18149594u^{10} t^6 + 8952972u^{11} t^5 + 3259172u^{12} t^4 + 816896u^{13} t^3 + 123366u^{14} t^2 + 8108u^{15} t + 193u^{16} \Big) s^6 + 6tu \left( 157t^{15} + 4612ut^{14} \right. \\
& + 39024u^2 t^{13} + 191670u^3 t^{12} + 643658u^4 t^{11} + 1557030u^5 t^{10} + 2799334u^6 t^9 + 3770803u^7 t^8 + 3770803u^8 t^7 + 2799334u^9 t^6 \\
& + 1557030u^{10} t^5 + 643658u^{11} t^4 + 191670u^{12} t^3 + 39024u^{13} t^2 + 4612u^{14} t + 157u^{15} \Big) s^5 + t^2 u^2 \left( 2883t^{14} + 38608ut^{13} + 269730u^2 t^{12} \right. \\
& + 1182108u^3 t^{11} + 3470348u^4 t^{10} + 7219608u^5 t^9 + 11105895u^6 t^8 + 12818744u^7 t^7 + 11105895u^8 t^6 + 7219608u^9 t^5 + 3470348u^{10} t^4 \\
& + 1182108u^{11} t^3 + 269730u^{12} t^2 + 38608u^{13} t + 2883u^{14} \Big) s^4 + 4t^3 u^3 \left( 647t^{13} + 9737ut^{12} + 60783u^2 t^{11} + 220492u^3 t^{10} + 533350u^4 t^9 \right. \\
& + 931704u^5 t^8 + 1224463u^6 t^7 + 1224463u^7 t^6 + 931704u^8 t^5 + 533350u^9 t^4 + 220492u^{10} t^3 + 60783u^{11} t^2 + 9737u^{12} t + 647u^{13} \Big) s^3 \\
& + 3 t^4 u^4 (t + u)^2 \left( 961t^{10} + 7506ut^9 + 28145u^2 t^8 + 66084u^3 t^7 + 107838u^4 t^6 + 127716u^5 t^5 + 107838u^6 t^4 + 66084u^7 t^3 + 28145u^8 t^2 \right. \\
& + 7506u^9 t + 961u^{10} \Big) s^2 + 6t^5 u^5 (t + u)^3 \left( 157t^8 + 937u t^7 + 2766u^2 t^6 + 5043u^3 t^5 + 6226u^4 t^4 + 5043u^5 t^3 + 2766u^6 t^2 + 937u^7 t \right. \\
& + 157u^8 \Big) s + t^6 u^6 (t + u)^6 \left( 193t^4 + 354ut^3 + 537u^2 t^2 + 354 u^3 t + 193u^4 \right) \Big) H(2, y) \Big\} / \left( 27s^3 t^3 u^3 (s + t)^6 (s + u)^6 (t + u)^6 \right)
\end{aligned}$$

$$\mathcal{A}_{5;CA}^{(2)} = \left\{ 216s^2 t^2 u^3 (s + u)^6 (t + u)^6 (s^2 - ts + t^2 + u^2) H(0, 1, y) (s + t)^7 + 162s^2 t^3 u^3 (s + u)^6 (t + u)^6 (t^2 + u^2) H(0, y) H(0, z) (s + t)^6 \right.$$

$$\begin{aligned}
& + 54s^2 t^2 u^3 (s + u)^6 (t + u)^6 \left( 16s^3 - 21us^2 + 7u^2 s + t (16t^2 - 21ut + 7u^2) \right) H(0, z) H(1, y) (s + t)^6 - 54s^2 t^2 u^3 (s + u)^6 (t + u)^6 \left( 10s^3 \right. \\
& - 21us^2 + 19u^2 s + t (-8t^2 + 21ut - 17 u^2) \Big) H(0, y) H(1, z) (s + t)^6 + 1134s^2 t^2 u^3 (s + u)^6 (t + u)^6 \left( s^3 - 2us^2 \right. \\
& + u^2 s + t(t - u)^2 \Big) H(1, y) H(1, z) (s + t)^6 + 54s^2 t^2 u^2 (s + u)^6 (t + u)^6 \left( -2(5t + 8u)s^3 + 21(t^2 + u^2) s^2 - (19t^3 \right. \\
& + 7u^3) s + tu(t^2 + u^2) \Big) H(0, z) H(2, y) (s + t)^6 + 54s^2 t^2 u^2 (s + u)^6 (t + u)^6 \left( -4(5t + 6u)s^3 + 21(t^2 + 2u^2) s^2 \right. \\
& - (11t^3 + 24u^3) s + tu(t^2 + u^2) \Big) H(1, z) H(2, y) (s + t)^6 + 162s^3 t^2 u^2 (s + u)^6 (t + u)^6 \left( 2(t + u)s^2 - 7(t^2 \right. \\
& + u^2) s + 5(t^3 + u^3) \Big) H(1, z) H(3, y) (s + t)^6 + 162s^2 t^3 u^3 (s + u)^6 (t + u)^6 \left( 2t^2 - 7ut + 5u^2 \right) H(0, 0, y) (s + t)^6
\end{aligned}$$

$$\begin{aligned}
& + 162s^2 t^3 u^3 (s + u)^6 (t + u)^6 \left( 5t^2 - 7ut + 2u^2 \right) H(0, 0, z) (s + t)^6 + 54s^2 t^2 u^3 (s + u)^6 (t + u)^6 \left( 7s^3 - 21us^2 + 16u^2 s + t(25t^2 - 42ut \right. \\
& + 25 u^2) \Big) H(0, 1, z) (s + t)^6 + 54s^2 t^2 u^2 (s + u)^6 (t + u)^6 \left( (t - 10u)s^3 + 21u^2 s^2 + (t^3 - 19u^3) s + 21t(t - u)^2 u \right) H(0, 2, y) (s + t)^6 \\
& + 54s^2 t^2 u^3 (s + u)^6 (t + u)^6 \left( 10s^3 - 21u s^2 + 19u^2 s + t^3 + tu^2 \right) H(1, 0, y) (s + t)^6 - 54s^2 t^2 u^3 (s + u)^6 (t + u)^6 \left( 16s^3 - 21us^2 + 7u^2 s \right. \\
& - 2t(t^2 + u^2) \Big) H(1, 0, z) (s + t)^6 - 54s^2 t^2 u^3 (s + u)^6 (t + u)^6 \left( s^3 - 21us^2 + 10u^2 s + t(t^2 - 21ut + 10u^2) \right) H(1, 1, y) (s + t)^6 \\
& - 162s^2 t^2 u^3 (s + u)^6 (t + u)^6 \left( 8s^3 - 14us^2 + 8u^2 s + t(-4t^2 + 7ut - 7 u^2) \right) H(1, 1, z) (s + t)^6 + 1134s^2 t^2 u^3 (s + u)^6 (t + u)^6 \left( s^3 \right. \\
& - 2us^2 + u^2 s + t(t - u)^2 \Big) H(1, 2, y) (s + t)^6 + 54s^2 t^2 u^2 (s + u)^6 (t + u)^6 \left( -2(8t + 5u)s^3 + 21(t^2 + u^2) s^2 - (7 t^3 \right. \\
& + 19u^3) s + tu(t^2 + u^2) \Big) H(2, 0, y) (s + t)^6 + 54s^2 t^2 u^3 (s + u)^6 (t + u)^6 \left( 4s^3 - 21us^2 + 13u^2 s + t^3 + tu^2 \right) H(2, 1, y) (s + t)^6 \\
& - 324s^3 t^2 u^2 (s + u)^6 (t + u)^6 \left( 4(t + u)s^2 - 7(t^2 + u^2) s + 4(t^3 + u^3) \right) H(2, 2, y) (s + t)^6 + 162 s^3 t^2 u^2 (s + u)^6 (t + u)^6 \left( 2(t + u)s^2 \right. \\
& - 7(t^2 + u^2) s + 5(t^3 + u^3) \Big) H(3, 2, y) (s + t)^6 - 9s^2 t^2 u^2 (t + u)^6 \left( 10 s^{14} + (60t + 74u)s^{13} + 2(85t^2 + 94ut + 129u^2) s^{12} + 3(100t^3 \right. \\
& + 74ut^2 + 123u^2 t + 190u^3) s^{11} + (360t^4 + 199u t^3 + 954u^2 t^2 + 467u^3 t + 900u^4) s^{10} + (300t^5 - 194ut^4 + 4854 u^2 t^3 + 635u^3 t^2 + 348u^4 t \\
& + 1074u^5) s^9 + 2(85t^6 - 429u t^5 + 4734u^2 t^4 + 2414u^3 t^3 - 498u^4 t^2 + 135u^5 t + 492u^6) s^8 + (60t^7 - 874ut^6 + 8919u^2 t^5 + 5677u^3 t^4 \\
& + 1791u^4 t^3 - 159u^5 t^2 + 165u^6 t + 678u^7) s^7 + (10t^8 - 337ut^7 + 4848u^2 t^6 - 2634 u^3 t^5 + 4506u^4 t^4 + 5835u^5 t^3 + 288u^6 t^2 + 39u^7 t \\
& + 330u^8) s^6 + u \left( -36t^8 + 1746ut^7 - 7930u^2 t^6 + 1614u^3 t^5 + 14679u^4 t^4 + 3583u^5 t^3 - 339u^6 t^2 + 150u^7 t + 100u^8 \right) s^5 + u^2 \left( 360t^8 \right. \\
& - 4417u t^7 - 1014u^2 t^6 + 13797u^3 t^5 + 8278u^4 t^4 - 689u^5 t^3 + 306u^6 t^2 + 172u^7 t + 14u^8 \Big) s^4 + tu^3 \left( -708t^7 - 45ut^6 + 4974u^2 t^5 \right. \\
& + 6885u^3 t^4 + 1171u^4 t^3 - 108u^5 t^2 + 489u^6 t + 44u^7 \Big) s^3 + 3t^2 u^4 \left( 120 t^6 + 114ut^5 + 580u^2 t^4 + 562u^3 t^3 + 152u^4 t^2 + 117u^5 t + 42u^6 \right) s^2 \\
& + t^3 u^5 \left( -36t^5 - 53ut^4 + 526u^2 t^3 + 402u^3 t^2 + 271u^4 t + 104 u^5 \right) s + t^4 u^6 \left( 10t^4 + 40ut^3 + 72u^2 t^2 + 49u^3 t + 56 u^4 \right) \Big) H(0, y) (s + t)^2 \\
& + 9s^2 t^2 u^2 (s + u)^6 (t + u)^6 \left( 6 s^8 + (78t + 22u)s^7 + (324t^2 + 202ut + 42u^2) s^6 + 3(230 t^3 + 202ut^2 + 186u^2 t + 7u^3) s^5 + (876t^4 \right. \\
& + 962ut^3 + 1710u^2 t^2 + 103u^3 t + 58u^4) s^4 + 2t(345t^4 + 481ut^3 + 1194u^2 t^2 + 38 u^3 t + 122u^4) s^3 + 2t^2(162t^4 + 303ut^3 + 855u^2 t^2 \\
& + 38u^3 t + 162u^4) s^2 + t^3(78t^4 + 202ut^3 + 558u^2 t^2 + 103u^3 t + 244 u^4) s + t^4(6t^4 + 22ut^3 + 42u^2 t^2 + 21u^3 t + 58 u^4) \Big) H(1, y) (s + t)^2
\end{aligned}$$

$$\begin{aligned}
& -\frac{3}{2}t^2u^2(s+u)\left(462(t+u)^6s^{16}+6\left(533t^7+3647ut^6+11355u^2t^5+18041u^3t^4+18041u^4t^3+11355u^5t^2+3647u^6t+533u^7\right)s^{15}\right. \\
& +6(t+u)^2\left(1725t^6+9572ut^5+26881u^2t^4+27580u^3t^3+26881u^4t^2+9572u^5t+1725u^6\right)s^{14}+\left(20814t^9+169590ut^8+698271u^2t^7\right. \\
& +1572623u^3t^6+2180718u^4t^5+2180718u^5t^4+1572623u^6t^3+698271u^7t^2+169590u^8t+20814u^9\right)s^{13}+(t+u)^2\left(28872t^8+187896ut^7\right. \\
& +702435u^2t^6+1379212u^3t^5+1402562u^4t^4+1379212u^5t^3+702435u^6t^2+187896u^7t+28872u^8\right)s^{12}+\left(28752t^{11}+247032u^2t^{10}\right. \\
& +1200159u^2t^9+3905948u^3t^8+7929314u^4t^7+10661099u^5t^6+10661099u^6t^5+7929314u^7t^4+3905948u^8t^3+1200159u^9t^2 \\
& +247032u^{10}t+28752u^{11}\right)s^{11}+(t+u)^2\left(20598t^{10}+137298u^2t^9+671079u^2t^8+2337710u^3t^7+4295427u^4t^6+4577312u^5t^5\right. \\
& +4295427u^6t^4+2337710u^7t^3+671079u^8t^2+137298u^9t+20598u^{10}\right)s^{10}+\left(10230t^{13}+94398ut^{12}+670143u^2t^{11}+3176397u^3t^{10}\right. \\
& +9253014u^4t^9+16795202u^5t^8+21138216u^6t^7+21138216u^7t^6+16795202u^8t^5+9253014u^9t^4+3176397u^{10}t^3+670143u^{11}t^2 \\
& +94398u^{12}t+10230u^{13}\right)s^9+(t+u)^2\left(3174t^{12}+28308u^2t^{11}+353829u^2t^{10}+1598364u^3t^9+3798910u^4t^8+5149552u^5t^7\right. \\
& +4884942u^6t^6+5149552u^7t^5+3798910u^8t^4+1598364u^9t^3+353829u^{10}t^2+28308u^{11}t+3174u^{12}\right)s^8+\left(462t^{15}+7482u^2t^{14}\right. \\
& +190719u^2t^{13}+1263290u^3t^{12}+4354796u^4t^{11}+9652847u^5t^{10}+14817008u^6t^9+17262724u^7t^8+17262724u^8t^7+14817008u^9t^6 \\
& +9652847u^{10}t^5+4354796u^{11}t^4+1263290u^{12}t^3+190719u^{13}t^2+7482u^{14}t+462u^{15}\right)s^7+tu(t+u)^2\left(690t^{12}+52407u^2t^{11}\right. \\
& +300320u^2t^{10}+958425u^3t^9+2341562u^4t^8+3965828u^5t^7+4535936u^6t^6+3965828u^7t^5+2341562u^8t^4+958425u^9t^3+300320u^{10}t^2 \\
& +52407u^{11}t+690u^{12}\right)s^6+t^2u^2\left(6786t^{13}+57592ut^{12}+322024u^2t^{11}+1440278u^3t^{10}+4550721u^4t^9+9574691u^5t^8+13690372u^6t^7\right. \\
& +13690372u^7t^6+9574691u^8t^5+4550721u^9t^4+1440278u^{10}t^3+322024u^{11}t^2+57592u^{12}t+6786u^{13}\right)s^5+t^3u^3(t+u)^2\left(74t^{10}\right. \\
& +34768ut^9+270574u^2t^8+947815u^3t^7+1872940u^4t^6+2304682u^5t^5+1872940u^6t^4+947815u^7t^3+270574u^8t^2+34768u^9t \\
& +74u^{10}\right)s^4+t^4u^4(t+u)^3\left(4432t^8+44590ut^7+177657u^2t^6+382429u^3t^5+481348u^4t^4+382429u^5t^3+177657u^6t^2+44590u^7t\right. \\
& +4432u^8\right)s^3+t^5u^5(t+u)^4\left(2948t^6+20395ut^5+53828u^2t^4+72306u^3t^3+53828u^4t^2+20395u^5t+2948u^6\right)s^2+720t^6u^6(t+u)^7\left(2t^2\right. \\
& +3ut+2u^2\right)s+288t^7u^7(t+u)^6\left(t^2+ut+u^2\right)\left(s+t\right)-9s^2t^2u^2(s+u)^2(t+u)^6\left(10s^{14}+(74t+60u)s^{13}+2\left(129t^2+94ut+85u^2\right)s^{12}\right. \\
& +3\left(190t^3+123ut^2+74u^2t+100u^3\right)s^{11}+\left(900t^4+467ut^3+954u^2t^2+199u^3t+360u^4\right)s^{10}+\left(1074t^5+348ut^4+635u^2t^3\right. \\
& +4854u^3t^2-194u^4t+300u^5\right)s^9+2\left(492t^6+135ut^5-498u^2t^4+2414u^3t^3+4734u^4t^2-429u^5t+85u^6\right)s^8+\left(678t^7+165ut^6\right. \\
& -159u^2t^5+1791u^3t^4+5677u^4t^3+8919u^5t^2-874u^6t+60u^7\right)s^7+\left(330t^8+39ut^7+288u^2t^6+5835u^3t^5+4506u^4t^4-2634u^5t^3\right. \\
& +4848u^6t^2-337u^7t+10u^8\right)s^6+t\left(100t^8+150ut^7-339u^2t^6+3583u^3t^5+14679u^4t^4+1614u^5t^3-7930u^6t^2+1746u^7t-36u^8\right)s^5 \\
& +t^2\left(14t^8+172ut^7+306u^2t^6-689u^3t^5+8278u^4t^4+13797u^5t^3-1014u^6t^2-4417u^7t+360u^8\right)s^4+t^3u\left(44t^7+489u^6t-108u^2t^5\right. \\
& +1171u^3t^4+6885u^4t^3+4974u^5t^2-45u^6t-708u^7\right)s^3+3t^4u^2\left(42t^6+117ut^5+152u^2t^4+562u^3t^3+580u^4t^2+114u^5t+120u^6\right)s^2 \\
& +t^5u^3\left(104t^5+271ut^4+402u^2t^3+526u^3t^2-53u^4t-36u^5\right)s+t^6u^4\left(56t^4+49ut^3+72u^2t^2+40u^3t+10u^4\right)H(0,z) \\
& -9s^2t^2u^2\left(2\left(3t^6+60ut^5-78u^2t^4+490u^3t^3-78u^4t^2+60u^5t+3u^6\right)s^{16}+\left(72t^7+1289ut^6+414u^2t^5+8005u^3t^4+7845u^4t^3\right. \right. \\
& +126u^5t^2+1129u^6t+40u^7\right)s^{15}+6\left(60t^8+900ut^7+1076u^2t^6+4412u^3t^5+9687u^4t^4+3894u^5t^3+558u^6t^2+678u^7t+23u^8\right)s^{14} \\
& +\left(1024t^9+12954ut^8+24576u^2t^7+46761u^3t^6+163314u^4t^5+154677u^5t^4+29274u^6t^3+11781u^7t^2+8316u^8t+331u^9\right)s^{13} \\
& +\left(1874t^{10}+20222ut^9+53220u^2t^8+61201u^3t^7+246846u^4t^6+451965u^5t^5+210152u^6t^4+17091u^7t^3+26370u^8t^2+11421u^9t\right. \\
& +638u^{10}\right)s^{12}+3\left(780t^{11}+7249u^2t^{10}+25014u^2t^9+30013u^3t^8+86909u^4t^7+276042u^5t^6+269826u^6t^5+71475u^7t^4+13798u^8t^3\right. \\
& +15298u^9t^2+4109u^{10}t+359u^{11}\right)s^{11}+\left(2042t^{12}+16125ut^{11}+76122u^2t^{10}+155760u^3t^9+296460u^4t^8+1068120u^5t^7\right. \\
& +1786074u^6t^6+1133742u^7t^5+352110u^8t^4+166875u^9t^3+68808u^{10}t^2+12114u^{11}t+1520u^{12}\right)s^{10}+\left(1240t^{13}+7152ut^{12}\right. \\
& +58566u^2t^{11}+232980u^3t^{10}+464512u^4t^9+1090308u^5t^8+2341921u^6t^7+2520886u^7t^6+1455108u^8t^5+740077u^9t^4+345463u^{10}t^3 \\
& +84624u^{11}t^2+10790u^{12}t+1573u^{13}\right)s^9+3\left(168t^{14}+208ut^{13}+10592u^2t^{12}+73981u^3t^{11}+192464u^4t^{10}+350678u^5t^9+731518u^6t^8\right.
\end{aligned}$$

$$\begin{aligned}
& + 1095507u^7t^7 + 938868u^8t^6 + 596751u^9t^5 + 345880u^{10}t^4 + 133260u^{11}t^3 + 25570u^{12}t^2 + 2627u^{13}t + 352u^{14})s^8 + (124t^{15} \\
& - 1050ut^{14} + 11760u^2t^{13} + 109681u^3t^{12} + 348969u^4t^{11} + 744780u^5t^{10} + 1812415u^6t^9 + 3571941u^7t^8 + 4045692u^8t^7 + 2838503u^9t^6 \\
& + 1635744u^{10}t^5 + 818670u^{11}t^4 + 274406u^{12}t^3 + 50556u^{13}t^2 + 4374u^{14}t + 403u^{15})s^7 + (14t^{16} - 459ut^{15} + 4194u^2t^{14} + 16667u^3t^{13} \\
& + 21936u^4t^{12} + 169446u^5t^{11} + 1113116u^6t^{10} + 3298442u^7t^9 + 4969926u^8t^8 + 4145565u^9t^7 + 2172862u^{10}t^6 + 899067u^{11}t^5 \\
& + 350974u^{12}t^4 + 118004u^{13}t^3 + 24360u^{14}t^2 + 1596u^{15}t + 66u^{16})s^6 + 3tu(-20t^{15} + 510ut^{14} - 2846u^2t^{13} - 25726u^3t^{12} \\
& - 36057u^4t^{11} + 137862u^5t^{10} + 687022u^6t^9 + 1363652u^7t^8 + 1488125u^8t^7 + 962136u^9t^6 + 387285u^{10}t^5 + 104624u^{11}t^4 + 27898u^{12}t^3 \\
& + 10766u^{13}t^2 + 2505u^{14}t + 88u^{15})s^5 + t^2u^2(276t^{14} - 4915u^1t^{13} - 35832u^2t^{12} - 60573u^3t^{11} + 131822u^4t^{10} + 839823u^5t^9 \\
& + 1989780u^6t^8 + 2753037u^7t^7 + 2394378u^8t^6 + 1355826u^9t^5 + 497554u^{10}t^4 + 108936u^{11}t^3 + 16362u^{12}t^2 + 4782u^{13}t + 1056u^{14})s^4 \\
& + t^3u^3(-820t^{13} - 4665ut^{12} - 3330u^2t^{11} + 50014u^3t^{10} + 234315u^4t^9 + 583398u^5t^8 + 954377u^6t^7 + 1055745u^7t^6 + 809880u^8t^5 \\
& + 443150u^9t^4 + 168838u^{10}t^3 + 40614u^{11}t^2 + 5192u^{12}t + 196u^{13})s^3 + 3t^4u^4(t+u)^2(92t^{10} + 476ut^9 + 2090u^2t^8 + 7269u^3t^7 \\
& + 17036u^4t^6 + 25733u^5t^5 + 22780u^6t^4 + 14183u^7t^3 + 6446u^8t^2 + 2047u^9t + 352u^{10})s^2 - t^5u^5(t+u)^3(60t^8 + 29ut^7 - 1449u^2t^6 \\
& - 4932u^3t^5 - 8177u^4t^4 - 6609u^5t^3 - 3504u^6t^2 - 1214u^7t - 264u^8)st^6u^6(t+u)^6(14t^4 + 90ut^3 + 126u^2t^2 + 89u^3t + 66u^4)H(1, z) \\
& - 9s^2t^2u^2(2(6t^6 + 78u^5 - 33u^2t^4 + 550u^3t^3 - 33u^4t^2 + 78u^5t + 6u^6)s^{16} + (130t^7 + 1727ut^6 + 1824u^2t^5 + 10515u^3t^4 \\
& + 10515u^4t^3 + 1824u^5t^2 + 1727u^6t + 130u^7)s^{15} + 6(104t^8 + 1295u^1t^7 + 2603u^2t^6 + 7743u^3t^5 + 14182u^4t^4 + 7743u^5t^3 \\
& + 2603u^6t^2 + 1295u^7t + 104u^8)s^{14} + (1747t^9 + 20760ut^8 + 60177u^2t^7 + 138345u^3t^6 + 311235u^4t^5 + 311235u^5t^4 + 138345u^6t^3 \\
& + 60177u^7t^2 + 20760u^8t + 1747u^9)s^{13} + (3218t^{10} + 37773ut^9 + 146652u^2t^8 + 339358u^3t^7 + 769808u^4t^6 + 1107894u^5t^5 \\
& + 769808u^6t^4 + 339358u^7t^3 + 146652u^8t^2 + 37773u^9t + 3218u^{10})s^{12} + 3(1403t^{11} + 16697u^1t^{10} + 82856u^2t^9 + 227499u^3t^8 \\
& + 514057u^4t^7 + 898468u^5t^6 + 898468u^6t^5 + 514057u^7t^4 + 227499u^8t^3 + 82856u^9t^2 + 16697u^{10}t + 1403u^{11})s^{11} + 2(2050t^{12} \\
& + 24939ut^{11} + 154530u^2t^{10} + 531155u^3t^9 + 1271385u^4t^8 + 2420490u^5t^7 + 3112438u^6t^6 + 2420490u^7t^5 + 1271385u^8t^4 \\
& + 531155u^9t^3 + 154530u^{10}t^2 + 24939u^{11}t + 2050u^{12})s^{10} + (2989t^{13} + 37142ut^{12} + 287298u^2t^{11} + 1240898u^3t^{10} + 3321201u^4t^9 \\
& + 6609462u^5t^8 + 9856850u^6t^7 + 9856850u^7t^6 + 6609462u^8t^5 + 3321201u^9t^4 + 1240898u^{10}t^3 + 287298u^{11}t^2 + 37142u^{12}t \\
& + 2989u^{13})s^9 + 3(514t^{14} + 6775ut^{13} + 65664u^2t^{12} + 346961u^3t^{11} + 1076100u^4t^{10} + 2314869u^5t^9 + 3821756u^6t^8 + 4598458u^7t^7 \\
& + 3821756u^8t^6 + 2314869u^9t^5 + 1076100u^{10}t^4 + 346961u^{11}t^3 + 65664u^{12}t^2 + 6775u^{13}t + 514u^{14})s^8 + (493t^{15} + 8076ut^{14} \\
& + 98952u^2t^{13} + 596673u^3t^{12} + 2146416u^4t^{11} + 5342982u^5t^{10} + 10174467u^6t^9 + 14554545u^7t^8 + 14554545u^8t^7 + 10174467u^9t^6 \\
& + 5342982u^{10}t^5 + 2146416u^{11}t^4 + 596673u^{12}t^3 + 98952u^{13}t^2 + 8076u^{14}t + 493u^{15})s^7 + (72t^{16} + 2194ut^{15} + 36630u^2t^{14} \\
& + 227075u^3t^{13} + 910630u^4t^{12} + 2784993u^5t^{11} + 6611664u^6t^{10} + 11660494u^7t^9 + 14240640u^8t^8 + 11660494u^9t^7 + 6611664u^{10}t^6 \\
& + 2784993u^{11}t^5 + 910630u^{12}t^4 + 227075u^{13}t^3 + 36630u^{14}t^2 + 2194u^{15}t + 72u^{16})s^6 + 3tu(100t^{15} + 3071ut^{14} + 18464u^2t^{13} \\
& + 80084u^3t^{12} + 323267u^4t^{11} + 1009711u^5t^{10} + 2219756u^6t^9 + 3327843u^7t^8 + 3327843u^8t^7 + 2219756u^9t^6 + 1009711u^{10}t^5 \\
& + 323267u^{11}t^4 + 80084u^{12}t^3 + 18464u^{13}t^2 + 3071u^{14}t + 100u^{15})s^5 + t^2u^2(1146t^{14} + 7452ut^{13} + 43332u^2t^{12} + 256857u^3t^{11} \\
& + 1020516u^4t^{10} + 2637270u^5t^9 + 4640688u^6t^8 + 5609726u^7t^7 + 4640688u^8t^6 + 2637270u^9t^5 + 1020516u^{10}t^4 + 256857u^{11}t^3 \\
& + 43332u^{12}t^2 + 7452u^{13}t + 1146u^{14})s^4 + t^3u^3(316t^{13} + 7702ut^{12} + 60600u^2t^{11} + 260422u^3t^{10} + 721307u^4t^9 + 1402338u^5t^8 \\
& + 1962295u^6t^7 + 1962295u^7t^6 + 1402338u^8t^5 + 721307u^9t^4 + 260422u^{10}t^3 + 60600u^{11}t^2 + 7702u^{12}t + 316u^{13})s^3 \\
& + 3t^4u^4(t+u)^2(382t^{10} + 2457u^1t^9 + 8650u^2t^8 + 21232u^3t^7 + 376224u^4t^6 + 46842u^5t^5 + 37622u^6t^4 + 21232u^7t^3 + 8650u^8t^2 \\
& + 2457u^9t + 382u^{10})s^2 + t^5u^5(t+u)^3(300t^8 + 1544ut^7 + 4776u^2t^6 + 9573u^3t^5 + 12690u^4t^4 + 9573u^5t^3 + 4776u^6t^2 \\
& + 1544u^7t + 300u^8)st^6u^6(t+u)^6(24t^4 + 37ut^3 + 56u^2t^2 + 37u^3t + 24u^4)H(2, y) \Big\} / (27s^3t^3u^3(s+t)^6(s+u)^6(t+u)^6)
\end{aligned}$$

$$\begin{aligned}
\mathcal{A}_{5;CFnf}^{(2)} = & \left\{ -432s^2t^2(s^2 - ts + t^2)u^3(s+u)^6(t+u)^6H(0, z)H(1, y)(s+t)^7 - 324s^2t^2u^3(s+u)^6(t+u)^6(s^2 - ts \right. \\
& + t^2 + u^2)H(1, y)H(1, z)(s+t)^7 - 108s^2t^2u^3(s+u)^6(t+u)^6(s^2 - ts + t^2 - 3u^2)H(1, 1, y)(s+t)^7 \\
& - 324s^2t^2u^3(s+u)^6(t+u)^6(s^2 - ts + t^2 + u^2)H(1, 2, y)(s+t)^7 + 108s^2t^3u^3(s+u)^6(t+u)^6(t^2 + u^2)H(0, y)H(0, z)(s+t)^6 \\
& \left. + 432s^2(s-t)t^2u^5(s+u)^6(t+u)^6H(0, y)H(1, z)(s+t)^6 + 432s^3t^2u^2(s+u)^6(t+u)^6(t^3 + s^2u)H(0, z)H(2, y)(s+t)^6 \right\}
\end{aligned}$$



$$\begin{aligned}
& +108s^3t^2u^2(s+u)^6(t+u)^6(3u^3+s^2(4t+3u))H(1,z)H(2,y)(s+t)^6-432s^3t^2u^2(s+u)^6(t+u)^7(t^2-ut+u^2)H(1,z)H(3,y)(s+t)^6 \\
& -432s^2t^3u^5(s+u)^6(t+u)^6H(0,0,y)(s+t)^6-432s^2t^5u^3(s+u)^6(t+u)^6H(0,0,z)(s+t)^6-108s^2t^2u^3(s+u)^6(t+u)^6(3t^3+3u^2t \\
& +4su^2)H(0,1,z)(s+t)^6+108s^2t^2u^3(s+u)^6(t+u)^6(-3t^3-3u^2t+4su^2)H(0,2,y)(s+t)^6+108s^2t^2u^3(s+u)^6(t+u)^6(t^3 \\
& +u^2t-4su^2)H(1,0,y)(s+t)^6+108s^2t^2u^3(s+u)^6(t+u)^6(4s^3+t^3+tu^2)H(1,0,z)(s+t)^6+108s^2t^2u^3(s+u)^6(t+u)^6(3s^3 \\
& +3u^2s-4tu^2)H(1,1,z)(s+t)^6+432s^3t^2u^2(s+u)^6(t+u)^6(u^3+s^2t)H(2,0,y)(s+t)^6+108s^3t^2u^3(s+u)^6(t+u)^6(s^2 \\
& -3u^2)H(2,1,y)(s+t)^6+324s^3t^2u^2(s+u)^6(t+u)^7(s^2+t^2+u^2-tu)H(2,2,y)(s+t)^6-432s^3t^2u^2(s+u)^6(t+u)^7(t^2-ut \\
& +u^2)H(3,2,y)(s+t)^6-18s^2t^2u^3(s+u)^6(t+u)^6(9(t+2u)s^4+9(3t^2+6ut+2u^2)s^3+(27t^3+72ut^2+12u^2t+16u^3)s^2+t(9t^3 \\
& +54u^2t^2+12u^2t+20u^3)s+2t^2u(9t^2+9ut+8u^2))H(1,y)(s+t)^4-18s^2t^3u^3(t+u)^6(18s^{11}+51(t+2u)s^{10}+(33t^2+360ut \\
& +203u^2)s^9+(-27t^3+498ut^2+705u^2t+156u^3)s^8+(-39t^4+420ut^3+776u^2t^2+546u^3t-63u^4)s^7-3(4t^5-108ut^4-91u^2t^3 \\
& -106u^3t^2+21u^4t+98u^5)s^6-3u(-64t^5-9ut^4+98u^2t^3+142u^3t^2+236u^4t+121u^5)s^5-u(-48t^6-44ut^5+174u^2t^4+711u^3t^3 \\
& +1102u^4t^2+897u^5t+240u^6)s^4-u^2(-16t^6-100ut^5+333u^2t^4+948u^3t^3+1084u^4t^2+558u^5t+83u^6)s^3-3u^3(-16t^6+8ut^5 \\
& +124u^2t^4+199u^3t^3+182u^4t^2+60u^5t+4u^6)s^2-tu^5(52t^4+135ut^3+186u^2t^2+147u^3t+24u^4)s-2t^2u^6(4t^3+9ut^2+13u^2t \\
& +8u^3)H(0,y)(s+t)^3-12t^3u^3(s+u)(24tu(3t^3+4ut^2+4u^2t+3u^3)s^{15}-6(t+u)^2(19t^4-7ut^3+86u^2t^2-7u^3t+19u^4)s^{14} \\
& -(528t^7+2241ut^6+5905u^2t^5+10806u^3t^4+10806u^4t^3+5905u^5t^2+2241u^6t+528u^7)s^{13}-(t+u)^2(999t^6+3708ut^5+7757u^2t^4 \\
& +13636u^3t^3+7757u^4t^2+3708u^5t+999u^6)s^{12}-(945t^9+6444ut^8+18478u^2t^7+38524u^3t^6+60985u^4t^5+60985u^5t^4+38524u^6t^3 \\
& +18478u^7t^2+6444u^8t+945u^9)s^{11}-(t+u)^2(408t^8+1419ut^7-737u^2t^6-1221u^3t^5+6934u^4t^4-1221u^5t^3-737u^6t^2+1419u^7t \\
& +408u^8)s^{10}+2(-9t^{11}+1365ut^{10}+9543u^2t^9+28308u^3t^8+43963u^4t^7+44166u^5t^6+44166u^6t^5+43963u^7t^4+28308u^8t^3 \\
& +9543u^9t^2+1365u^{10}t-9u^{11})s^9+(t+u)^2(33t^{10}+3726ut^9+16908u^2t^8+31720u^3t^7+24859u^4t^6+8028u^5t^5+24859u^6t^4 \\
& +31720u^7t^3+16908u^8t^2+3726u^9t+33u^{10})s^8+(3t^{13}+2076ut^{12}+13514u^2t^{11}+34430u^3t^{10}+33548u^4t^9-29287u^5t^8 \\
& -114020u^6t^7-114020u^7t^6-29287u^8t^5+33548u^9t^4+34430u^{10}t^3+13514u^{11}t^2+2076u^{12}t+3u^{13})s^7+tu(t+u)^2(615t^{10} \\
& +2129u^9-2862u^2t^8-27958u^3t^7-70915u^4t^6-96406u^5t^5-70915u^6t^4-27958u^7t^3-2862u^8t^2+2129u^9t+615u^{10})s^6 \\
& +tu(87t^{13}+151ut^{12}-4613u^2t^{11}-33895u^3t^{10}-117246u^4t^9-252106u^5t^8-365426u^6t^7-365426u^7t^6-252106u^8t^5-117246u^9t^4 \\
& -33895u^{10}t^3-4613u^{11}t^2+151u^{12}t+87u^{13})s^5-t^2u^2(t+u)^2(61t^{10}+1421ut^9+9539u^2t^8+31118u^3t^7+60284u^4t^6+74918u^5t^5 \\
& +60284u^6t^4+31118u^7t^3+9539u^8t^2+1421u^9t+61u^{10})s^4-t^3u^3(t+u)^3(119t^8+1631ut^7+6699u^2t^6+14006u^3t^5+17750u^4t^4 \\
& +14006u^5t^3+6699u^6t^2+1631u^7t+119u^8)s^3-t^4u^4(t+u)^4(133t^6+842ut^5+1972u^2t^4+2532u^3t^3+1972u^4t^2+842u^5t+133u^6)s^2 \\
& -6t^5u^5(t+u)^7(8t^2+9ut+8u^2)s-6t^6u^6(t+u)^6(t^2+ut+u^2)(s+t)-18s^2t^3u^3(s+u)^3(t+u)^6(18s^{11}+51(2t+u)s^{10}+(203t^2 \\
& +360ut+33u^2)s^9+3(52t^3+235ut^2+166u^2t-9u^3)s^8+(-63t^4+546ut^3+776u^2t^2+420u^3t-39u^4)s^7-3(98t^5+21ut^4-106u^2t^3 \\
& -91u^3t^2-108u^4t+4u^5)s^6-3t(121t^5+236ut^4+142u^2t^3+98u^3t^2-9u^4t-64u^5)s^5-t(240t^6+897ut^5+1102u^2t^4+711u^3t^3 \\
& +174u^4t^2-44u^5t-48u^6)s^4-t^2(83t^6+558ut^5+1084u^2t^4+948u^3t^3+333u^4t^2-100u^5t-16u^6)s^3-3t^3(4t^6+60ut^5+182u^2t^4 \\
& +199u^3t^3+124u^4t^2+8u^5t-16u^6)s^2-t^5u(24t^4+147u^3t^3+186u^2t^2+135u^3t+52u^4)s-2t^6u^2(8t^3+13ut^2+9u^2t+4u^3)H(0,z) \\
& +18s^2t^2u^3(16t^2u(3t^2+ut+3u^2)s^{16}-4t(t^5-96ut^4-125u^2t^3-125u^3t^2-96u^4t+u^5)s^{15}+3(-21t^7+376ut^6+969u^2t^5 \\
& +1014u^3t^4+1053u^4t^3+460u^5t^2+15u^6t+6u^7)s^{14}+3(-91t^8+434ut^7+2445u^2t^6+3548u^3t^5+4121u^4t^4+3594u^5t^3 \\
& +1259u^6t^2+200u^7t+42u^8)s^{13}+(-507t^9-228ut^8+8958u^2t^7+21034u^3t^6+29016u^4t^5+37554u^5t^4+27842u^6t^3 \\
& +10398u^7t^2+2643u^8t+394u^9)s^{12}+3(-139t^{10}-658ut^9+1402u^2t^8+7968u^3t^7+14642u^4t^6+25576u^5t^5+31288u^6t^4 \\
& +20652u^7t^3+8197u^8t^2+2094u^9t+242u^{10})s^{11}+(-33t^{11}-1944ut^{10}-2626u^2t^9+15924u^3t^8+52455u^4t^7+115368u^5t^6 \\
& +193671u^6t^5+189594u^7t^4+109994u^8t^3+41340u^9t^2+9291u^{10}t+870u^{11})s^{10}+(229t^{12}-1206ut^{11}-7826u^2t^{10}+2016u^3t^9 \\
& +60801u^4t^8+168742u^5t^7+312211u^6t^6+377892u^7t^5+285136u^8t^4+142036u^9t^3+47343u^{10}t^2+9112u^{11}t+698u^{12})s^9 \\
& +3(69t^{13}-396ut^{12}-3542u^2t^{11}-3876u^3t^{10}+19403u^4t^9+74332u^5t^8+145298u^6t^7+193458u^7t^6+172121u^8t^5+103198u^9t^4 \\
& +43468u^{10}t^3+12394u^{11}t^2+2015u^{12}t+122u^{13})s^8+(81t^{14}-1338ut^{13}-9602u^2t^{12}-15144u^3t^{11}+41583u^4t^{10}+217006u^5t^9 \\
& +472374u^6t^8+692016u^7t^7+711667u^8t^6+501642u^9t^5+246150u^{10}t^4+85492u^{11}t^3+19953u^{12}t^2+2646u^{13}t+114u^{14})s^7
\end{aligned}$$

$$\begin{aligned}
& + \left( 12t^{15} - 936ut^{14} - 5785u^2t^{13} - 9734u^3t^{12} + 23766u^4t^{11} + 151768u^5t^{10} + 374411u^6t^9 + 611526u^7t^8 + 725603u^8t^7 + 609872u^9t^6 \right. \\
& + 355422u^{10}t^5 + 143724u^{11}t^4 + 39635u^{12}t^3 + 7044u^{13}t^2 + 696u^{14}t + 16u^{15} \Big) s^6 + 3tu \left( -112t^{14} - 711ut^{13} - 1428u^2t^{12} + 2680u^3t^{11} \right. \\
& + 24408u^4t^{10} + 73333u^5t^9 + 137580u^6t^8 + 184601u^7t^7 + 179614u^8t^6 + 124026u^9t^5 + 59992u^{10}t^4 + 19831u^{11}t^3 + 4174u^{12}t^2 + 496u^{13}t \\
& + 28u^{14} \Big) s^5 + t^2u \left( -48t^{14} - 380ut^{13} - 1422u^2t^{12} - 453u^3t^{11} + 19778u^4t^{10} + 90336u^5t^9 + 213354u^6t^8 + 330336u^7t^7 + 360906u^8t^6 \right. \\
& + 281670u^9t^5 + 156716u^{10}t^4 + 61605u^{11}t^3 + 16236u^{12}t^2 + 2470u^{13}t + 144u^{14} \Big) s^4 + t^3u^2 \left( -16t^{13} - 340ut^{12} - 1209u^2t^{11} + 1822u^3t^{10} \right. \\
& + 23522u^4t^9 + 76164u^5t^8 + 142722u^6t^7 + 179964u^7t^6 + 159444u^8t^5 + 99732u^9t^4 + 43795u^{10}t^3 + 13194u^{11}t^2 + 2510u^{12}t + 232u^{13} \Big) s^3 \\
& - 3t^4u^3(t+u)^2 \left( 16t^{10} + 56ut^9 - 124u^2t^8 - 1147u^3t^7 - 3208u^4t^6 - 5170u^5t^5 - 5528u^6t^4 - 3835u^7t^3 - 1676u^8t^2 - 424u^9t \right. \\
& - 48u^{10} \Big) s^2 + t^5u^5(t+u)^3 \left( 52t^7 + 321ut^6 + 921u^2t^5 + 1569u^3t^4 + 1779u^4t^3 + 1230u^5t^2 + 484u^6t + 84u^7 \right) s + 2t^6u^6(t+u)^7 \left( 4t^2 \right. \\
& + 5ut + 8u^2 \Big) H(1, z) + 18s^2t^2u^2 \left( 16t^2u^2(3t^2 + ut + 3u^2) s^{16} - 4tu(t^5 - 96ut^4 - 125u^2t^3 - 125u^3t^2 - 96u^4t + u^5) s^{15} + 6(3t^8 \right. \\
& + 9ut^7 + 242u^2t^6 + 567u^3t^5 + 582u^4t^4 + 567u^5t^3 + 242u^6t^2 + 9u^7t + 3u^8) s^{14} + 3(42t^9 + 221u^8t^8 + 1445u^2t^7 + 4311u^3t^6 \\
& + 5693u^4t^5 + 5693u^5t^4 + 4311u^6t^3 + 1445u^7t^2 + 221u^8t + 42u^9) s^{13} + 2(197t^{10} + 1416u^9t^9 + 6153u^2t^8 + 18148u^3t^7 + 29594u^4t^6 \\
& + 32160u^5t^5 + 29594u^6t^4 + 18148u^7t^3 + 6153u^8t^2 + 1416u^9t + 197u^{10}) s^{12} + 3(242t^{11} + 2199ut^{10} + 9451u^2t^9 + 27134u^3t^8 \\
& + 50612u^4t^7 + 62634u^5t^6 + 62634u^6t^5 + 50612u^7t^4 + 27134u^8t^3 + 9451u^9t^2 + 2199u^{10}t + 242u^{11}) s^{11} + 2(435t^{12} + 4803ut^{11} \\
& + 23010u^2t^{10} + 69466u^3t^9 + 145491u^4t^8 + 210555u^5t^7 + 230976u^6t^6 + 210555u^7t^5 + 145491u^8t^4 + 69466u^9t^3 + 23010u^{10}t^2 \\
& + 4803u^{11}t + 435u^{12}) s^{10} + (698t^{13} + 9301ut^{12} + 51105u^2t^{11} + 170974u^3t^{10} + 406704u^4t^9 + 698997u^5t^8 + 884941u^6t^7 + 884941u^7t^6 \\
& + 698997u^8t^5 + 406704u^9t^4 + 170974u^{10}t^3 + 51105u^{11}t^2 + 9301u^{12}t + 698u^{13}) s^9 + 6(61t^{14} + 1018ut^{13} + 6515u^2t^{12} + 24975u^3t^{11} \\
& + 68497u^4t^{10} + 139578u^5t^9 + 209143u^6t^8 + 237090u^7t^7 + 209143u^8t^6 + 139578u^9t^5 + 68497u^{10}t^4 + 24975u^{11}t^3 + 6515u^{12}t^2 \\
& + 1018u^{13}t + 61u^{14}) s^8 + (114t^{15} + 2655ut^{14} + 20511u^2t^{13} + 93946u^3t^{12} + 304122u^4t^{11} + 729081u^5t^{10} + 1284397u^6t^9 + 1678662u^7t^8 \\
& + 1678662u^8t^7 + 1284397u^9t^6 + 729081u^{10}t^5 + 304122u^{11}t^4 + 93946u^{12}t^3 + 20511u^{13}t^2 + 2655u^{14}t + 114u^{15}) s^7 + 2(8t^{16} + 348ut^{15} \\
& + 3558u^2t^{14} + 20893u^3t^{13} + 82679u^4t^{12} + 233298u^5t^{11} + 478228u^6t^{10} + 720901u^7t^9 + 821694u^8t^8 + 720901u^9t^7 + 478228u^{10}t^6 \\
& + 233298u^{11}t^5 + 82679u^{12}t^4 + 20893u^{13}t^3 + 3558u^{14}t^2 + 348u^{15}t + 8u^{16}) s^6 + 3tu \left( 28t^{15} + 496ut^{14} + 4255u^2t^{13} + 21403u^3t^{12} \right. \\
& + 71760u^4t^{11} + 172018u^5t^{10} + 302499u^6t^9 + 397333u^7t^8 + 397333u^8t^7 + 302499u^9t^6 + 172018u^{10}t^5 + 71760u^{11}t^4 + 21403u^{12}t^3 \\
& + 4255u^{13}t^2 + 496u^{14}t + 28u^{15} \Big) s^5 + 2t^2u^2(72t^{14} + 1235u^3t^{13} + 8343u^2t^{12} + 34020u^3t^{11} + 97435u^4t^{10} + 204801u^5t^9 + 317982u^6t^8 \\
& + 367512u^7t^7 + 317982u^8t^6 + 204801u^9t^5 + 97435u^{10}t^4 + 34020u^{11}t^3 + 8343u^{12}t^2 + 1235u^{13}t + 72u^{14}) s^4 + t^3u^3(232t^{13} + 2510ut^{12} \\
& + 13689u^2t^{11} + 49393u^3t^{10} + 127070u^4t^9 + 236640u^5t^8 + 321522u^6t^7 + 321522u^7t^6 + 236640u^8t^5 + 127070u^9t^4 + 49393u^{10}t^3 \\
& + 13689u^{11}t^2 + 2510u^{12}t + 232u^{13}) s^3 + 6t^4u^4(t+u)^2(24t^{10} + 212ut^9 + 892u^2t^8 + 2315u^3t^7 + 4004u^4t^6 + 4762u^5t^5 + 4004u^6t^4 \\
& + 2315u^7t^3 + 892u^8t^2 + 212u^9t + 24u^{10}) s^2 + t^5u^5(t+u)^3(84t^8 + 484ut^7 + 1347u^2t^6 + 2364u^3t^5 + 2802u^4t^4 + 2364u^5t^3 + 1347u^6t^2 \\
& + 484u^7t + 84u^8) s + 2t^6u^6(t+u)^6(8t^4 + 13ut^3 + 18u^2t^2 + 13u^3t + 8u^4) H(2, y) \Big) / (27s^3t^3u^3(s+t)^6(s+u)^6(t+u)^6)
\end{aligned}$$

$$\begin{aligned}
\mathcal{A}_{5;n_2}^{(2)} &= 2 \left\{ t^3uH(2, y) + t^3uH(1, z) - tu(t^2 + u^2)H(0, y) - tu(t^2 + u^2)H(0, z) + tu^3H(2, y) + t^3u^3H(1, z) \right. \\
& \left. + s^4 + 2s^3t + 2s^3u + 3s^2t^2 + 3s^2u^2 + 2st^3 + 2su^3 + t^4 + 2t^3u + 3t^2u^2 + 2tu^3 + u^4 \right\} / (3stu)
\end{aligned}$$

$$\begin{aligned}
\mathcal{A}_{6;C_A}^{(2)} &= \left\{ 3s^2t^2(s+t)^6u^2(t+u)^2 \left( (363t^4 + 492ut^3 + 504u^2t^2 + 492u^3t + 363u^4) s^4 + 2(363t^5 + 479ut^4 - 58u^2t^3 - 58u^3t^2 + 479u^4t \right. \right. \\
& + 363u^5) s^3 + 9(t+u)^2(121t^4 - 10ut^3 - 134u^2t^2 - 10u^3t + 121u^4) s^2 + 6(t+u)^3(121t^4 + 35ut^3 + 12u^2t^2 + 35u^3t + 121u^4) s \\
& + 363(t+u)^4(t^2 + ut + u^2)^2 H(1, z) H(2, y)(s+u)^6 + 3s^2t^2(s+t)^2u^2(t+u)^6(363s^8 + 726(3t+u)s^7 + 3(2057t^2 + 796ut + 363u^2) s^6 \\
& + 6(1815t^3 + 480ut^2 + 348u^2t + 121u^3) s^5 + (13068t^4 + 1782ut^3 - 297u^2t^2 + 958u^3t + 363u^4) s^4 + 2t(5445t^4 + 891ut^3 - 1296u^2t^2 \\
& - 58u^3t + 246u^4) s^3 + t^2(6171t^4 + 2880ut^3 - 297u^2t^2 - 116u^3t + 504u^4) s^2 + 2t^3(1089t^4 + 1194ut^3 + 1044u^2t^2 + 479u^3t + 246u^4) s \\
& + 363t^4(t^2 + ut + u^2)^2 H(0, 0, y)(s+u)^6 + 36s^2t^2(s+t)^2u^2(t+u)^6(22s^8 + 44(3t+u)s^7 + 2(187t^2 + 70ut + 33u^2) s^6 + (660t^3 \\
& + 147ut^2 + 246u^2t + 44u^3) s^5 + (792t^4 + 41ut^3 + 360u^2t^2 + 115u^3t + 22u^4) s^4 + t(660t^4 + 2ut^3 + 246u^2t^2 + 95u^3t + 64u^4) s^3 \\
& + t^2(374t^4 + 54u^3t + 84u^2t^2 + 9u^3t + 84u^4) s^2 + t^3(132t^4 + 63u^3t + 36u^2t^2 - 11u^3t + 54u^4) s + t^4(22t^4 + 21ut^3 + 18u^2t^2 + 4u^3t \\
& + 18u^4) H(0, z) H(0, 0, y)(s+u)^6 - 36s^2t^2(s+t)^2u^2(t+u)^6(22s^8 + 3(44t+7u)s^7 + (374t^2 + 63ut + 18u^2) s^6 + (660t^3 + 54ut^2 \\
& + 36u^2t + 4u^3) s^5 + (792t^4 + 2u^3t + 84u^2t^2 - 11u^3t + 18u^4) s^4 + t(660t^4 + 41ut^3 + 246u^2t^2 + 9u^3t + 54u^4) s^3 + t^2(374t^4 + 147ut^3 \\
& + 360u^2t^2 + 95u^3t + 84u^4) s^2 + t^3(132t^4 + 140ut^3 + 246u^2t^2 + 115u^3t + 64u^4) s + 22t^4(t^2 + ut + u^2)^2 H(1, z) H(0, 0, y)(s+u)^6
\end{aligned}$$

$$\begin{aligned}
& + 108s^2t^2(s+t)^6u^2(t+u)^6(2s^4+4(t+u)s^3+6(t^2+u^2)s^2+4(t^3+u^3)s+2t^4+2u^4-2tu^3-3t^2u^2 \\
& - 2t^3u)H(0,0,y)H(0,0,z)(s+u)^6+18s^2t^2(s+t)^6u^2(t+u)^2((44t^4+296ut^3+486u^2t^2+316u^3t+58u^4)s^4+2(15t^5+247ut^4 \\
& +634u^2t^3+646u^3t^2+271u^4t+27u^5)s^3+3(t+u)^2(5t^4+150ut^3+228u^2t^2+146u^3t+15u^4)s^2-2(t+u)^3(2t^4-91ut^3-90u^2t^2 \\
& -97u^3t-4u^4)s+(t+u)^4(11t^4+94ut^3+105u^2t^2+72u^3t+6u^4))H(3,y)H(0,1,z)(s+u)^6-108s^2t^2(s+t)^6u^2(t+u)^6(2s^4 \\
& +2(2t+u)s^3+3(2t^2+u^2)s^2+2(2t^3+u^3)s+2(t^4-2ut^3+6u^2t^2+u^4))H(0,0,y)H(0,1,z)(s+u)^6 \\
& +36s^2t^2(s+t)^6u^2(t+u)^2(2(11t^4+32ut^3+42u^2t^2+27u^3t+9u^4)s^4+(44t^5+115ut^4+95u^2t^3+9u^3t^2-11u^4t \\
& +4u^5)s^3+6(t+u)^2(11t^4+19ut^3+11u^2t^2+3u^4)s^2+(t+u)^3(44t^4+8ut^3-9u^2t^2+21u^4)s+22(t+u)^4(t^2+ut \\
& +u^2)^2)H(1,z)H(0,2,y)(s+u)^6-108s^2t^2(s+t)^6u^2(t+u)^6(2s^4+2(t+2u)s^3+3(t^2+2u^2)s^2+2(t^3+2u^3)s+2(t^4+6u^2t^2 \\
& -2u^3t+u^4))H(0,0,z)H(0,2,y)(s+u)^6+108s^2t^2(s+t)^6u^2(t+u)^6(-2(t-2u)s^3-3(t^2-2u^2)s^2-2(t^3-2u^3)s+12tu(t^2-ut \\
& +u^2))H(0,1,z)H(0,2,y)(s+u)^6+216s^2t^2(s+t)^6u^2(t+u)^6(s^4+2us^3+3u^2s^2+2u^3s+(t^2+ut+u^2)^2)H(0,1,z)H(0,3,y)(s+u)^6 \\
& +18s^2t^2(s+t)^3u^2(t+u)^6(3s^7+(6u-9t)s^6+(48t^2+12ut+15u^2)s^5-(56t^3+6ut^2+63u^2t-12u^3)s^4-t^2(7t^2+36ut+222u^2)s^3 \\
& +3t(11t^4-14ut^3-70u^2t^2-8u^3t-8u^4)s^2+t^2(28t^4-24ut^3-81u^2t^2-24u^3t-30u^4)s+t^3(8t^4-6ut^3-15u^2t^2-12u^3t \\
& -14u^4))H(0,z)H(1,0,y)(s+u)^6-18s^2t^2(s+t)^3u^2(t+u)^6(8s^7+(28t-6u)s^6+3(11t^2-8ut-5u^2)s^5-(7t^3+42ut^2+81u^2t \\
& +12u^3)s^4-2(28t^4+18ut^3+105u^2t^2+12u^3t+7u^4)s^3-6t(8t^4+ut^3+37u^2t^2+4u^3t+5u^4)s^2-3(3t^6-4ut^5+21u^2t^4+8u^4t^2)s \\
& +3t^4(t^3+2ut^2+5u^2t+4u^3))H(1,z)H(1,0,y)(s+u)^6+108s^2t^2(s+t)^6u^2(t+u)^6(2s^4+2(2t+u)s^3+3(2t^2+u^2)s^2+2(2t^3+u^3)s \\
& +2t^4+2u^4-2tu^3+9t^2u^2-6t^3u)H(0,1,z)H(1,0,y)(s+u)^6-18s^2t^2(s+t)^6u^2(t+u)^3(2t(7t^2+15ut+12u^2)s^4+12(t^4+2ut^3 \\
& +2u^2t^2-u^4)s^3+3(t+u)^2(5t^3+17ut^2+31u^2t-5u^3)s^2+6(t+u)^3(t^3+ut^2+u^2t-u^3)s-(t+u)^3(8t^4+4ut^3-3u^2t^2-18u^3t \\
& +3u^4))H(3,y)H(1,0,z)(s+u)^6-108s^2t^2(s+t)^6u^2(t+u)^6(2s^4+4(t-u)s^3+6(t^2+2u^2)s^2+4t^3s+2t^4+2u^4+2tu^3+3t^2u^2 \\
& +2t^3u)H(0,0,y)H(1,0,z)(s+u)^6-216s^3t^2(s+t)^6u^2(t+u)^6(2(t-2u)s^2+3(t^2+u^2)s+2(t^3-u^3))H(0,2,y)H(1,0,z)(s+u)^6 \\
& +108s^2t^2(s+t)^6u^2(t+u)^6(2s^4+2(t+3u)s^3+3(t^2-u^2)s^2+2(t^3+5u^3)s+2(t^2+ut+u^2)^2)H(0,3,y)H(1,0,z)(s+u)^6 \\
& +108s^2t^2(s+t)^6u^2(t+u)^6(2s^4+(4t-6u)s^3+(6t^2+9u^2)s^2+(4t^3-2u^3)s+2t^4+2u^4+2tu^3+3t^2u^2 \\
& +2t^3u)H(1,0,y)H(1,0,z)(s+u)^6+3s^2t^2(s+t)^6u^2(t+u)^2((363t^4+492ut^3+504u^2t^2+492u^3t+363u^4)s^4+2(363t^5+479ut^4 \\
& -58u^2t^3-58u^3t^2+479u^4t+363u^5)s^3+9(t+u)^2(121t^4-10ut^3-134u^2t^2-10u^3t+121u^4)s^2+6(t+u)^3(121t^4+35ut^3+12u^2t^2 \\
& +35u^3t+121u^4)s+363(t+u)^4(t^2+ut+u^2)^2)H(1,1,z)(s+u)^6+36s^2t^2(s+t)^6u^2(t+u)^2(2(11t^4+32ut^3+42u^2t^2+27u^3t \\
& +9u^4)s^4+(44t^5+115ut^4+95u^2t^3+9u^3t^2-11u^4t+4u^5)s^3+6(t+u)^2(11t^4+19ut^3+11u^2t^2+3u^4)s^2+(t+u)^3(44t^4+8ut^3 \\
& -9u^2t^2+21u^4)s+22(t+u)^4(t^2+ut+u^2)^2)H(0,y)H(1,1,z)(s+u)^6-36s^2t^2(s+t)^6u^2(t+u)^2(2(20t^4+59ut^3+84u^2t^2+59u^3t \\
& +20u^4)s^4+8(6t^5+13ut^4+13u^2t^3+13u^3t^2+13u^4t+6u^5)s^3+6(t+u)^2(14t^4+19ut^3+22u^2t^2+19u^3t+14u^4)s^2+(t+u)^3(65t^4 \\
& +8u^3t^3-18u^2t^2+8u^3t+65u^4)s+44(t+u)^4(t^2+ut+u^2)^2)H(3,y)H(1,1,z)(s+u)^6+108s^2t^2(s+t)^6u^2(t+u)^6(2s^4 \\
& +(4t-2u)s^3+(6t^2-3u^2)s^2+(4t^3-2u^3)s+2(t^2+ut+u^2)^2)H(0,0,y)H(1,1,z)(s+u)^6-108s^2t^2(s+t)^6u^2(t+u)^6(4s^4 \\
& +(6t-2u)s^3+9(t^2+u^2)s^2+6(t^3-u^3)s+4(t^2+ut+u^2)^2)H(0,3,y)H(1,1,z)(s+u)^6+216s^2t^2(s+t)^6u^3(t+u)^6(2s^3 \\
& -3us^2+4u^2s+6t(t^2-ut+u^2))H(0,1,z)H(1,2,y)(s+u)^6-216s^2t^2(s+t)^6u^3(t+u)^6(6s^3-6us^2+6u^2s+t(2t^2-3ut \\
& +4u^2))H(1,0,z)H(1,2,y)(s+u)^6+36s^2t^2(s+t)^6u^2(t+u)^2(2(11t^4+32ut^3+42u^2t^2+27u^3t+9u^4)s^4+(44t^5+115ut^4+95u^2t^3 \\
& +9u^3t^2-11u^4t+4u^5)s^3+6(t+u)^2(11t^4+19ut^3+11u^2t^2+3u^4)s^2+(t+u)^3(44t^4+8ut^3-9u^2t^2+21u^4)s+22(t+u)^4(t^2+ut \\
& +u^2)^2)H(1,z)H(2,0,y)(s+u)^6-108s^2t^2(s+t)^6u^2(t+u)^6(2s^4-4(t-u)s^3+6(2t^2+u^2)s^2+4u^3s+2t^4+2u^4+2tu^3+3t^2u^2 \\
& +2t^3u)H(0,0,z)H(2,0,y)(s+u)^6-108s^2t^2(s+t)^6u^2(t+u)^6(4s^4+2(5t+2u)s^3+3(t^2+2u^2)s^2+2(7t^3+2u^3)s+4t^4+4u^4 \\
& +4tu^3+6t^2u^2+4t^3u)H(0,1,z)H(2,0,y)(s+u)^6-108s^2t^2(s+t)^6u^2(t+u)^6(4s^4+6ts^3+9(t^2+2u^2)s^2+(6t^3+4u^3)s+4t^4 \\
& +4u^4+6tu^3+9t^2u^2+6t^3u)H(1,0,z)H(2,0,y)(s+u)^6+3s^2t^2(s+t)^6u^2(t+u)^2((363t^4+492ut^3+504u^2t^2+492u^3t+363u^4)s^4 \\
& +2(363t^5+479ut^4-58u^2t^3-58u^3t^2+479u^4t+363u^5)s^3+9(t+u)^2(121t^4-10ut^3-134u^2t^2-10u^3t+121u^4)s^2+6(t+u)^3(121t^4 \\
& +35ut^3+12u^2t^2+35u^3t+121u^4)s+363(t+u)^4(t^2+ut+u^2)^2)H(2,2,y)(s+u)^6+36s^2t^2(s+t)^6u^2(t+u)^2(2(9t^4 \\
& +27u^3t^3+42u^2t^2+32u^3t+11u^4)s^4+(4t^5-11ut^4+9u^2t^3+95u^3t^2+115u^4t+44u^5)s^3+6(t+u)^2(3t^4+11u^2t^2 \\
& +19u^3t+11u^4)s^2+(t+u)^3(21t^4-9u^2t^2+8u^3t+44u^4)s+22(t+u)^4(t^2+ut+u^2)^2)H(0,z)H(2,2,y)(s+u)^6 \\
& +108s^2t^2(s+t)^6u^2(t+u)^6(2s^4-2(t-2u)s^3-3(t^2-2u^2)s^2-2(t^3-2u^3)s+2(t^2+ut+u^2)^2)H(0,0,z)H(2,2,y)(s+u)^6
\end{aligned}$$

$$\begin{aligned}
& + 432s^2t^2(s+t)^6u^2(t+u)^6(s^4+3(t^2+u^2)s^2-(t^3+u^3)s+(t^2+ut+u^2)^2)H(0,1,z)H(2,2,y)(s+u)^6 \\
& - 108s^2t^2(s+t)^6u^2(t+u)^6(4s^4-2(t+2u)s^3+3(5t^2+8u^2)s^2+2(t^3-2u^3)s+4(t^2+ut+u^2)^2)H(1,0,z)H(2,2,y)(s+u)^6 \\
& + 324s^2t^2(s+t)^6u^2(t+u)^6(2s^4+2(t+u)s^3+3(t^2+u^2)s^2+2(t^3+u^3)s+2(t^2+ut+u^2)^2)H(0,1,z)H(2,3,y)(s+u)^6 \\
& - 108s^2t^2(s+t)^6u^2(t+u)^6(2s^4+2(t+u)s^3+3(t^2+u^2)s^2+2(t^3+u^3)s+2(t^2+ut+u^2)^2)H(1,0,z)H(2,3,y)(s+u)^6 \\
& - 18s^2t^2(s+t)^6u^2(t+u)^3(2u(12t^2+15ut+7u^2)s^4-12(t^4-2u^2t^2-2u^3t-u^4)s^3-3(t+u)^2(5t^3-31ut^2-17u^2t \\
& - 5u^3)s^2-6(t+u)^3(t^3-ut^2-u^2t-u^3)s-(t+u)^3(3t^4-18ut^3-3u^2t^2+4u^3t+8u^4))H(1,z)H(3,0,y)(s+u)^6 \\
& - 108s^2t^2(s+t)^6u^2(t+u)^6(2s^4+2(t+u)s^3+3(t^2+u^2)s^2+2(t^3+u^3)s+2(t^2+ut+u^2)^2)H(0,1,z)H(3,0,y)(s+u)^6 \\
& - 108s^2t^2(s+t)^6u^2(t+u)^6(2s^4+10(t+u)s^3-3(t^2+u^2)s^2+6(t^3+u^3)s+2(t^2+ut+u^2)^2)H(1,0,z)H(3,0,y)(s+u)^6 \\
& - 216s^2t^2(s+t)^6u^2(t+u)^6(2s^4+2ts^3+9t^2s^2+2(t^2+ut+u^2)^2)H(1,1,z)H(3,0,y)(s+u)^6 \\
& - 18s^2t^2(s+t)^6u^2(t+u)^3(2t(7t^2+15ut+12u^2)s^4+12(t^4+2ut^3+2u^2t^2-u^4)s^3+3(t+u)^2(5t^3+17ut^2+31u^2t \\
& - 5u^3)s^2+6(t+u)^3(t^3+ut^2+u^2t-u^3)s-(t+u)^3(8t^4+4ut^3-3u^2t^2-18u^3t+3u^4))H(0,z)H(3,2,y)(s+u)^6 \\
& - 36s^2t^2(s+t)^6u^2(t+u)^2(2(20t^4+59ut^3+84u^2t^2+59u^3t+20u^4)s^4+8(6t^5+13ut^4+13u^2t^3+13u^3t^2+13u^4t+6u^5)s^3 \\
& +6(t+u)^2(14t^4+19ut^3+22u^2t^2+19u^3t+14u^4)s^2+(t+u)^3(65t^4+8ut^3-18u^2t^2+8u^3t+65u^4)s+44(t+u)^4(t^2+ut \\
& +u^2)^2)H(1,z)H(3,2,y)(s+u)^6+216s^2t^2(s+t)^6u^2(t+u)^6(2s^4+2ts^3+9t^2s^2+2(t^2+ut+u^2)^2)H(0,1,z)H(3,2,y)(s+u)^6 \\
& - 216s^2t^2(s+t)^6u^2(t+u)^6(2s^4+4(t+2u)s^3-3(t^2-u^2)s^2+2(t^3+3u^3)s+2(t^2+ut+u^2)^2)H(1,0,z)H(3,2,y)(s+u)^6 \\
& + 18s^2t^2(s+t)^6u^2(t+u)^2((58t^4+340ut^3+540u^2t^2+340u^3t+58u^4)s^4+2(21t^5+265ut^4+658u^2t^3+658u^3t^2+265u^4t \\
& +21u^5)s^3+6(t+u)^2(5t^4+86ut^3+138u^2t^2+86u^3t+5u^4)s^2+2(t+u)^3(t^4+97ut^3+96u^2t^2+97u^3t+u^4)s+3(t+u)^4(t^4 \\
& +30ut^3+36u^2t^2+30u^3t+u^4))H(1,z)H(3,3,y)(s+u)^6+216s^2t^2(s+t)^6u^2(t+u)^6(4s^4+(6t+4u)s^3+3(t^2+2u^2)s^2+4(2t^3 \\
& +u^3)s+4(t^2+ut+u^2)^2)H(0,1,z)H(3,3,y)(s+u)^6-216s^3t^2(s+t)^6u^3(t+u)^6(2s^2-3us+4u^2)H(1,0,z)H(3,3,y)(s+u)^6 \\
& + 216s^2t^2(s+t)^6u^2(t+u)^6(4s^4+2(t+u)s^3+9(t^2+u^2)s^2+4(t^2+ut+u^2)^2)H(1,1,z)H(3,3,y)(s+u)^6 \\
& + 216s^2t^2(s+t)^6u^2(t+u)^6(s^4+2(t+u)s^3+3(t^2+u^2)s^2+2(t^3+u^3)s+t^4+u^4+6t^2u^2-2t^3u)H(0,y)H(0,0,1,z)(s+u)^6 \\
& + 216s^2t^2(s+t)^6u^3(t+u)^6(2s^3-3us^2+4u^2s+6t(t^2-ut+u^2))H(1,y)H(0,0,1,z)(s+u)^6+108s^2t^2(s+t)^6u^2(t+u)^6(6s^4 \\
& +2(4t+u)s^3+15u^2s^2+2(6t^3-u^3)s+6(t^2+ut+u^2)^2)H(2,y)H(0,0,1,z)(s+u)^6+432s^2t^2(s+t)^6u^2(t+u)^6(2s^4+2(t+u)s^3 \\
& +3(t^2+u^2)s^2+2(t^3+u^3)s+2(t^2+ut+u^2)^2)H(3,y)H(0,0,1,z)(s+u)^6-36s^2t^2(s+t)^2u^2(t+u)^6(22s^8+3(44t+7u)s^7 \\
& + (374t^2+63ut+18u^2)s^6+(660t^3+54ut^2+36u^2t+4u^3)s^5+(792t^4+2ut^3+84u^2t^2-11u^3t+18u^4)s^4+(660t^4+41ut^3 \\
& +246u^2t^2+9u^3t+54u^4)s^3+t^2(374t^4+147ut^3+360u^2t^2+95u^3t+84u^4)s^2+t^3(132t^4+140u^3t^3+246u^2t^2+115u^3t+64u^4)s \\
& +22t^4(t^2+ut+u^2)^2)H(0,0,2,y)(s+u)^6+216s^2t^2(s+t)^6u^2(t+u)^6(s^4+2ts^3+3(t^2+2u^2)s^2+2(t^3-u^3)s+t^4+u^4 \\
& -2tu^3+6t^2u^2)H(0,z)H(0,0,2,y)(s+u)^6+108s^2t^2(s+t)^6u^2(t+u)^6(2s^4+(4t-2u)s^3+(6t^2-3u^2)s^2+(4t^3-2u^3)s \\
& +2(t^2+ut+u^2)^2)H(1,z)H(0,0,2,y)(s+u)^6-108s^2t^2(s+t)^6u^2(t+u)^6(4s^4+2(4t+u)s^3+3(4t^2+5u^2)s^2+(8t^3-2u^3)s \\
& +4(t^4-u^3+6u^2t^2-u^3t+u^4))H(1,z)H(0,0,3,y)(s+u)^6+108s^2t^2(s+t)^6u^2(t+u)^6(2s^4+2(2t+u)s^3+3(2t^2+u^2)s^2 \\
& +2(2t^3+u^3)s+2t^4+2u^4+2tu^3+3t^2u^2+2t^3u)H(0,z)H(0,1,0,y)(s+u)^6-108s^2t^2(s+t)^6u^2(t+u)^6(2s^4+2(2t+u)s^3 \\
& +3(2t^2+u^2)s^2+2(2t^3+u^3)s+2t^4+2u^4+2tu^3+3t^2u^2+2t^3u)H(1,z)H(0,1,0,y)(s+u)^6+108s^2t^2(s+t)^6u^2(t+u)^6(2s^4 \\
& + (4t-6u)s^3+(6t^2+9u^2)s^2+(4t^3-2u^3)s+2(t^4+u^4))H(0,y)H(0,1,0,z)(s+u)^6-216s^2t^2(s+t)^6u^3(t+u)^6(6s^3 \\
& -6us^2+6u^2s+t(2t^2-3ut+4u^2))H(1,y)H(0,1,0,z)(s+u)^6-108s^2t^2(s+t)^6u^2(t+u)^6(2s^4-2(2t+5u)s^3+3(4t^2 \\
& +5u^2)s^2-10u^3s+2(t^2+ut+u^2)^2)H(2,y)H(0,1,0,z)(s+u)^6+216s^3t^2(s+t)^6u^2(t+u)^6(4(t+u)s^2-3(t^2+u^2)s+2(t^3 \\
& +u^3))H(3,y)H(0,1,0,z)(s+u)^6-36s^2t^2(s+t)^6u^2(t+u)^2(2(11t^4+32ut^3+42u^2t^2+27u^3t+9u^4)s^4+(44t^5+115ut^4+95u^2t^3 \\
& +9u^3t^2-11u^4t+4u^5)s^3+6(t+u)^2(11t^4+19ut^3+11u^2t^2+3u^4)s^2+(t+u)^3(44t^4+8ut^3-9u^2t^2+21u^4)s+22(t+u)^4(t^2 \\
& +ut+u^2)^2)H(0,1,1,z)(s+u)^6-108s^2t^2(s+t)^6u^2(t+u)^6(2s^4+(4t-2u)s^3+(6t^2-3u^2)s^2+(4t^3-2u^3)s+2(t^2+ut \\
& +u^2)^2)H(0,y)H(0,1,1,z)(s+u)^6+216s^2t^2(s+t)^6u^2(t+u)^6(2s^4+2ts^3+9t^2s^2+2(t^2+ut+u^2)^2)H(3,y)H(0,1,1,z)(s+u)^6
\end{aligned}$$

$$\begin{aligned}
& -36s^2t^2(s+t)^2u^2(t+u)^6(22s^8+3(44t+7u)s^7+(374t^2+63ut+18u^2)s^6+(660t^3+54ut^2+36u^2t+4u^3)s^5+(792t^4+2ut^3 \\
& +84u^2t^2-11u^3t+18u^4)s^4+t(660t^4+41u^3t^3+246u^2t^2+9u^3t+54u^4)s^3+t^2(374t^4+147ut^3+360u^2t^2+95u^3t+84u^4)s^2 \\
& +t^3(132t^4+140ut^3+246u^2t^2+115u^3t+64u^4)s+22t^4(t^2+ut+u^2)^2)H(0,2,0,y)(s+u)^6+108s^2t^2(s+t)^6u^2(t+u)^6(2s^4 \\
& +12us^3+8u^3s+2t^4+2u^4+2tu^3+3t^2u^2+2t^3u)H(0,z)H(0,2,0,y)(s+u)^6+108s^2t^2(s+t)^6u^2(t+u)^6(2s^4+(4t-2u)s^3 \\
& +(6t^2-3u^2)s^2+(4t^3-2u^3)s+2(t^2+ut+u^2)^2)H(1,z)H(0,2,0,y)(s+u)^6+36s^2t^2(s+t)^6u^2(t+u)^2(2(11t^4 \\
& +32ut^3+42u^2t^2+27u^3t+9u^4)s^4+(44t^5+115ut^4+95u^2t^3+9u^3t^2-11u^4t+4u^5)s^3+6(t+u)^2(11t^4+19ut^3 \\
& +11u^2t^2+3u^4)s^2+(t+u)^3(44t^4+8ut^3-9u^2t^2+21u^4)s+22(t+u)^4(t^2+ut+u^2)^2)H(0,2,2,y)(s+u)^6 \\
& +108s^2t^2(s+t)^6u^2(t+u)^6(2s^4+2ts^3+3(t^2+4u^2)s^2+2(t^3-2u^3)s+2(t^2+ut+u^2)^2)H(0,z)H(0,2,2,y)(s+u)^6 \\
& -216s^2t^2(s+t)^6u^2(t+u)^6(s^4+2(t-u)s^3+3(t^2+u^2)s^2+2(t^3-2u^3)s+t^4+u^4-4tu^3+9t^2u^2-4t^3u)H(1,z)H(0,2,3,y)(s+u)^6 \\
& -216s^2t^2(s+t)^6u^2(t+u)^6(2s^4+2(t+u)s^3+3(t^2+u^2)s^2+2(t^3+u^3)s+2(t^2+ut+u^2)^2)H(1,z)H(0,3,0,y)(s+u)^6 \\
& +108s^2t^2(s+t)^6u^2(t+u)^6(2s^4+2(t+3u)s^3+3(t^2-u^2)s^2+2(t^3+5u^3)s+2(t^2+ut+u^2)^2)H(0,z)H(0,3,2,y)(s+u)^6 \\
& -108s^2t^2(s+t)^6u^2(t+u)^6(4s^4+(6t-2u)s^3+9(t^2+u^2)s^2+6(t^3-u^3)s+4(t^2+ut+u^2)^2)H(1,z)H(0,3,2,y)(s+u)^6 \\
& -108s^3t^2(s+t)^6u^2(t+u)^6(2(t+u)s^2+3(t^2-3u^2)s+2(t^3+3u^3))H(1,z)H(0,3,3,y)(s+u)^6+36s^2t^2(s+t)^2u^2(t+u)^6(44s^8 \\
& +264t+65u)s^7+(748t^2+203ut+84u^2)s^6+3(440t^3+67ut^2+94u^2t+16u^3)s^5+(1584t^4+43u^3t^3+444u^2t^2+104u^3t \\
& +40u^4)s^4+t(1320t^4+43ut^3+492u^2t^2+104u^3t+118u^4)s^3+t^2(748t^4+201ut^3+444u^2t^2+104u^3t+168u^4)s^2 \\
& +t^3(264t^4+203ut^3+282u^2t^2+104u^3t+118u^4)s+t^4(44t^4+65ut^3+84u^2t^2+48u^3t+40u^4)H(1,0,0,y)(s+u)^6 \\
& +216s^2t^2(s+t)^6u^2(t+u)^6(2s^4+4ts^3+(6t^2+9u^2)s^2+2(2t^3+u^3)s+2(t^4+u^4))H(0,z)H(1,0,0,y)(s+u)^6 \\
& -216s^2t^2(s+t)^6u^2(t+u)^6(2s^4+4ts^3+6t^2s^2+4t^3s+2t^4+2u^4+2tu^3+9t^2u^2)H(1,z)H(1,0,0,y)(s+u)^6 \\
& +108s^2t^2(s+t)^6u^2(t+u)^6(2s^4+4(t+u)s^3+6(t^2+u^2)s^2+4(t^3+u^3)s+2t^4+2u^4-2tu^3-3t^2u^2 \\
& -2t^3u)H(0,y)H(1,0,0,z)(s+u)^6-108s^2t^2(s+t)^6u^2(t+u)^6(2s^4-4(t-u)s^3+6(2t^2+u^2)s^2+4u^3s+2t^4+2u^4 \\
& +2tu^3+3t^2u^2+2t^3u)H(2,y)H(1,0,0,z)(s+u)^6-108s^2t^2(s+t)^6u^2(t+u)^6(2s^4+4ts^3+6t^2s^2+4t^3s+2t^4+2u^4 \\
& -2tu^3+9t^2u^2-6t^3u)H(0,y)H(1,0,1,z)(s+u)^6+216s^2t^2(s+t)^6u^3(t+u)^6(2s^3-3us^2+4u^2s+6t(t^2-ut \\
& +u^2))H(1,y)H(1,0,1,z)(s+u)^6-216s^2t^2(s+t)^6u^2(t+u)^6(2(t+2u)s^3-3t^2s^2+(4t^3+6u^3)s-tu(2t^2+3ut \\
& +2u^2))H(2,y)H(1,0,1,z)(s+u)^6+216s^2t^2(s+t)^6u^2(t+u)^6(2s^4+2ts^3+9t^2s^2+2(t^2+ut+u^2)^2)H(3,y)H(1,0,1,z)(s+u)^6 \\
& -18s^2t^2(s+t)^3u^2(t+u)^6(8s^7+(28t-6u)s^6+3(11t^2-8ut-5u^2)s^5-(7t^3+42ut^2+81u^2t+12u^3)s^4-2(28t^4+18u^3t^3 \\
& +105u^2t^2+12u^3t+7u^4)s^3-6t(8t^4+ut^3+37u^2t^2+4u^3t+5u^4)s^2-3(3t^6-4ut^5+21u^2t^4+8u^4t^2)s+3t^4(t^3+2ut^2 \\
& +5u^2t+4u^3))H(1,0,2,y)(s+u)^6+108s^2t^2(s+t)^6u^2(t+u)^6(2s^4+(4t+6u)s^3+(6t^2-3u^2)s^2+2(2t^3+5u^3)s+2t^4 \\
& +2u^4+10tu^3-3t^2u^2+6t^3u)H(0,z)H(1,0,2,y)(s+u)^6-216s^2t^2(s+t)^6u^3(t+u)^6(2s^3-3us^2+4u^2s+6t(t^2-ut \\
& +u^2))H(1,z)H(1,0,3,y)(s+u)^6-18s^2t^2(s+t)^2u^2(t+u)^6(3s^8+2(51t+u)s^7+(486t^2+200ut+30u^2)s^6+6(179t^3+130ut^2 \\
& +96u^2t+7u^3)s^5+2(687t^4+677ut^3+945u^2t^2+265u^3t+29u^4)s^4+2t(537t^4+677ut^3+1344u^2t^2+658u^3t+170u^4)s^3 \\
& +2t^2(243t^4+390ut^3+945u^2t^2+658u^3t+270u^4)s^2+2t^3(51t^4+100ut^3+288u^2t^2+265u^3t+170u^4)s+t^4(3t^4+2ut^3 \\
& +30u^2t^2+42u^3t+58u^4)H(1,1,0,y)(s+u)^6+216s^3t^2(s+t)^6u^3(t+u)^6(4s^2-3us+2u^2)H(0,z)H(1,1,0,y)(s+u)^6 \\
& -216s^2t^3(s+t)^6u^3(t+u)^6(4t^2-3ut+2u^2)H(1,z)H(1,1,0,y)(s+u)^6-216s^2t^2(s+t)^6u^2(t+u)^6(s^4+2(t-u)s^3+3(t^2 \\
& +2u^2)s^2+2t^3s+(t^2+ut+u^2)^2)H(0,y)H(1,1,0,z)(s+u)^6-216s^2t^2(s+t)^6u^3(t+u)^6(6s^3-6us^2+6u^2s+t(2t^2-3ut \\
& +4u^2))H(1,y)H(1,1,0,z)(s+u)^6-108s^2t^2(s+t)^6u^2(t+u)^6(8s^4+4(2t+u)s^3+12(t^2+3u^2)s^2+4(2t^3+u^3)s+8t^4+8u^4 \\
& +14tu^3+21t^2u^2+14t^3u)H(2,y)H(1,1,0,z)(s+u)^6-216s^2t^2(s+t)^6u^2(t+u)^6(2s^4+4(t+2u)s^3-3(t^2-u^2)s^2+2(t^3 \\
& +3u^3)s+2(t^2+ut+u^2)^2)H(3,y)H(1,1,0,z)(s+u)^6-18s^2t^2(s+t)^3u^2(t+u)^6(8s^7+(28t-6u)s^6+3(11t^2-8ut-5u^2)s^5 \\
& -(7t^3+42ut^2+81u^2t+12u^3)s^4-2(28t^4+18ut^3+105u^2t^2+12u^3t+7u^4)s^3-6t(8t^4+ut^3+37u^2t^2+4u^3t+5u^4)s^2-3(3t^6 \\
& -4ut^5+21u^2t^4+8u^4t^2)s+3t^4(t^3+2ut^2+5u^2t+4u^3))H(1,2,0,y)(s+u)^6+108s^2t^2(s+t)^6u^2(t+u)^6(2s^4+(4t-6u)s^3 \\
& +(6t^2+9u^2)s^2+(4t^3-2u^3)s+2t^4+2u^4+2tu^3+3t^2u^2+2t^3u)H(0,z)H(1,2,0,y)(s+u)^6+216s^2t^2(s+t)^6u^3(t+u)^6(2s^3 \\
\end{aligned}$$

$$\begin{aligned}
& -3us^2 + 4u^2s + 6t(t^2 - ut + u^2))H(1, z)H(1, 2, 3, y)(s+u)^6 - 36s^2t^2(s+t)^2u^2(t+u)^6 \left(22s^8 + 3(44t+7u)s^7 + (374t^2 + 63ut \right. \\
& + 18u^2) s^6 + (660t^3 + 54ut^2 + 36u^2t + 4u^3) s^5 + (792t^4 + 2u t^3 + 84u^2t^2 - 11u^3t + 18u^4) s^4 + t(660t^4 + 41ut^3 + 246u^2 t^2 \\
& + 9u^3t + 54u^4) s^3 + t^2(374t^4 + 147ut^3 + 360u^2t^2 + 95u^3 t + 84u^4) s^2 + t^3(132t^4 + 140ut^3 + 246u^2t^2 + 115u^3t + 64 u^4) s \\
& + 22t^4(t^2 + ut + u^2)^2)H(2, 0, 0, y)(s+u)^6 - 108 s^2t^2(s+t)^6u^2(t+u)^6(2s^4 + 4(t-u)s^3 + 6(t^2 + 2u^2) s^2 + 4t^3s + 2t^4 \\
& + 2u^4 + 2tu^3 + 3t^2u^2 + 2t^3u)H(0, z)H(2, 0, 0, y) (s+u)^6 + 108s^2t^2(s+t)^6u^2(t+u)^6(2s^4 + (4t-2u)s^3 + (6 t^2 - 3u^2) s^2 \\
& + (4t^3 - 2u^3) s + 2(t^2 + ut + u^2)^2)H(1, z)H(2, 0, 0, y)(s+u)^6 + 36s^2t^2(s+t)^6u^2(t+u)^2(2(11t^4 + 32ut^3 + 42u^2t^2 + 27u^3t \\
& + 9u^4) s^4 + (44t^5 + 115ut^4 + 95u^2t^3 + 9u^3t^2 - 11u^4t + 4u^5) s^3 + 6(t+u)^2(11t^4 + 19ut^3 + 11u^2t^2 + 3u^4) s^2 + (t+u)^3(44 t^4 \\
& + 8ut^3 - 9u^2t^2 + 21u^4) s + 22(t+u)^4(t^2 + ut + u^2)^2)H(2, 0, 2, y)(s+u)^6 - 108s^2t^2(s+t)^6u^2(t+u)^6(2s^4 + 2(t+4u)s^3 \\
& + 3t^2s^2 + 2(t^3 + 6u^3) s + 2(t^4 + u^4))H(0, z)H(2, 0, 2, y)(s+u)^6 - 216s^2t^2(s+t)^6 u^2(t+u)^6(s^4 + (4t-2u)s^3 + 3u^2s^2 \\
& + (6t^3 - 4u^3) s + (t^2 + ut + u^2)^2)H(1, z)H(2, 0, 3, y)(s+u)^6 - 108s^2t^2(s+t)^6u^2(t+u)^6(2s^4 + 2(2t+5u)s^3 + (6t^2 \\
& - 3u^2) s^2 + (4t^3 + 6u^3) s + 2t^4 + 2u^4 + 2tu^3 + 3t^2u^2 + 2t^3u) H(0, z)H(2, 1, 0, y)(s+u)^6 - 216s^2t^2(s+t)^6u^2(t+u)^6(2s^4 \\
& + 2(2 t+u)s^3 + 3(2t^2 + u^2) s^2 + 2(2t^3 + u^3) s + 2t^4 + 2 u^4 + 2tu^3 + 3t^2u^2 + 2t^3u)H(1, z)H(2, 1, 0, y)(s+u)^6 \\
& + 36s^2t^2(s+t)^6u^2(t+u)^2(2(11t^4 + 32ut^3 + 42u^2t^2 + 27u^3t + 9 u^4) s^4 + (44t^5 + 115ut^4 + 95u^2t^3 + 9u^3t^2 - 11u^4t \\
& + 4 u^5) s^3 + 6(t+u)^2(11t^4 + 19ut^3 + 11u^2t^2 + 3u^4) s^2 + (t+u)^3(44t^4 + 8ut^3 - 9u^2t^2 + 21u^4) s + 22(t+u)^4(t^2 + ut \\
& + u^2)^2)H(2, 2, 0, y)(s+u)^6 - 216s^2t^2(s+t)^6u^2(t+u)^6(s^4 - 2(t+u)s^3 + 6(t^2 + u^2) s^2 + (t^2 + ut + u^2)^2)H(0, z)H(2, 2, 0, y)(s+u)^6 \\
& + 432s^2t^2(s+t)^6u^2(t+u)^6(s^4 + 3(t^2 + u^2) s^2 - (t^3 + u^3) s + (t^2 + ut + u^2)^2)H(1, z)H(2, 2, 3, y)(s+u)^6 \\
& - 108s^2t^2(s+t)^6u^2(t+u)^6(2s^4 + 2(t+u)s^3 + 3(t^2 + u^2) s^2 + 2(t^3 + u^3) s + 2(t^2 + ut + u^2)^2)H(1, z)H(2, 3, 0, y) (s+u)^6 \\
& - 108s^2t^2(s+t)^6u^2(t+u)^6(2s^4 + 2(t+u)s^3 + 3(t^2 + u^2) s^2 + 2(t^3 + u^3) s + 2(t^2 + ut + u^2)^2)H(0, z)H(2, 3, 2, y)(s+u)^6 \\
& + 432s^2t^2(s+t)^6u^2(t+u)^6(2s^4 + 2(t+u)s^3 + 3(t^2 + u^2) s^2 + 2(t^3 + u^3) s + 2(t^2 + ut + u^2)^2)H(1, z)H(2, 3, 3, y) (s+u)^6 \\
& - 18s^2t^2(s+t)^6u^2(t+u)^3(2u(12t^2 + 15ut + 7 u^2) s^4 - 12(t^4 - 2u^2t^2 - 2u^3t - u^4) s^3 - 3(t+u)^2(5t^3 - 31ut^2 - 17u^2t \\
& - 5u^3) s^2 - 6(t+u)^3(t^3 - ut^2 - u^2 t - u^3) s - (t+u)^3(3t^4 - 18ut^3 - 3u^2t^2 + 4u^3t + 8 u^4))H(3, 0, 2, y)(s+u)^6 \\
& - 108s^2t^2(s+t)^6u^2(t+u)^6(2 s^4 + 2(t-u)s^3 + 3(t^2 + 3u^2) s^2 + 2(t^3 - 3u^3) s + 2(t^2 + ut + u^2)^2)H(0, z)H(3, 0, 2, y)(s+u)^6 \\
& - 216s^2t^2(s+t)^6u^2(t+u)^6(2s^4 + 2ts^3 + 9t^2s^2 + 2(t^2 + ut + u^2)^2)H(1, z)H(3, 0, 2, y)(s+u)^6 - 216s^3t^2(s+t)^6u^3(t+u)^6(2s^2 \\
& - 3us + 4u^2)H(1, z)H(3, 0, 3, y)(s+u)^6 - 18s^2t^2(s+t)^6u^2(t+u)^3(2u(12t^2 + 15ut + 7u^2) s^4 - 12(t^4 - 2u^2t^2 - 2u^3t \\
& - u^4) s^3 - 3(t+u)^2(5t^3 - 31ut^2 - 17 u^2t - 5u^3) s^2 - 6(t+u)^3(t^3 - ut^2 - u^2t - u^3) s - (t+u)^3(3t^4 - 18ut^3 - 3u^2t^2 \\
& + 4u^3t + 8u^4))H(3, 2, 0, y) (s+u)^6 - 108s^2t^2(s+t)^6u^2(t+u)^6(2s^4 + 10(t+u)s^3 - 3(t^2 + u^2) s^2 + 6(t^3 + u^3) s + 2(t^2 + ut \\
& + u^2)^2)H(0, z)H(3, 2, 0, y)(s+u)^6 - 216s^2t^2(s+t)^6u^2(t+u)^6(2s^4 + 2ts^3 + 9t^2s^2 + 2(t^2 + ut + u^2)^2) H(1, z)H(3, 2, 0, y)(s+u)^6 \\
& - 36s^2t^2(s+t)^6u^2(t+u)^2(2(20 t^4 + 59ut^3 + 84u^2t^2 + 59u^3t + 20u^4) s^4 + 8(6t^5 + 13ut^4 + 13 u^2t^3 + 13u^3t^2 + 13u^4t + 6u^5) s^3 \\
& + 6(t+u)^2(14t^4 + 19u t^3 + 22u^2t^2 + 19u^3t + 14u^4) s^2 + (t+u)^3(65t^4 + 8ut^3 - 18 u^2t^2 + 8u^3t + 65u^4) s + 44(t+u)^4(t^2 + ut \\
& + u^2)^2) H(3, 2, 2, y)(s+u)^6 - 216s^2t^2(s+t)^6u^2(t+u)^6(2s^4 + 2us^3 + 9u^2 s^2 + 2(t^2 + ut + u^2)^2)H(0, z)H(3, 2, 2, y)(s+u)^6 \\
& + 216s^2 t^2(s+t)^6u^2(t+u)^6(4s^4 + 2(t+u)s^3 + 9(t^2 + u^2) s^2 + 4(t^2 + ut + u^2)^2)H(1, z)H(3, 2, 3, y)(s+u)^6 - 216s^3t^3(s+t)^6(2s^2 \\
& - 3ts + 4t^2) u^2(t+u)^6 H(1, z)H(3, 3, 0, y) (s+u)^6 + 18s^2t^2(s+t)^6u^2(t+u)^2((58t^4 + 340ut^3 + 540u^2 t^2 + 340u^3t + 58u^4) s^4 + 2(21t^5 \\
& + 265ut^4 + 658u^2t^3 + 658u^3 t^2 + 265u^4t + 21u^5) s^3 + 6(t+u)^2(5t^4 + 86ut^3 + 138u^2 t^2 + 86u^3t + 5u^4) s^2 + 2(t+u)^3(t^4 + 97ut^3 \\
& + 96u^2t^2 + 97u^3 t + u^4) s + 3(t+u)^4(t^4 + 30ut^3 + 36u^2t^2 + 30u^3 t + u^4))H(3, 3, 2, y)(s+u)^6 - 216s^3t^2(s+t)^6u^3(t+u)^6(2s^2 \\
& - 3us + 4u^2)H(0, z)H(3, 3, 2, y)(s+u)^6 + 216s^2t^2(s+t)^6 u^2(t+u)^6(4s^4 + 2(t+u)s^3 + 9(t^2 + u^2) s^2 + 4(t^2 + ut \\
& + u^2)^2)H(1, z)H(3, 3, 2, y)(s+u)^6 + 216s^2t^2(s+t)^6u^2(t+u)^6(4s^4 + 6(t+u)s^3 + 3(t^2 + u^2) s^2 + 8(t^3 + u^3) s + 4(t^2 + ut \\
& + u^2)^2)H(1, z)H(3, 3, 3, y) (s+u)^6 - 324s^2t^2(s+t)^6u^3(t+u)^6(2s^3 + 3us^2 + 2u^2s - 4t(t^2 - ut + u^2))H(0, 0, 0, 1, z)(s+u)^6
\end{aligned}$$

$$\begin{aligned}
& + 432s^2t^2(s+t)^6u^2(t+u)^6(s^4+(2t-u)s^3+3(t^2+u^2)s^2+2t^3s+t^4+u^4+3t^2u^2-t^3u)H(0,0,1,0,y)(s+u)^6 \\
& + 432s^2t^2(s+t)^6u^3(t+u)^6(3s^3+2u^2s-2t^3-3tu^2)H(0,0,1,0,z)(s+u)^6+108s^2t^2(s+t)^6u^2(t+u)^6(2s^4+(4t-2u)s^3+(6t^2 \\
& -3u^2)s^2+(4t^3-2u^3)s+2(t^2+ut+u^2)^2)H(0,0,1,1,z)(s+u)^6+108s^2t^2(s+t)^6u^2(t+u)^6(2s^4+(4t-2u)s^3+(6t^2-3u^2)s^2 \\
& + (4t^3-2u^3)s+2(t^2+ut+u^2)^2)H(0,0,2,2,y)(s+u)^6-108s^2t^2(s+t)^6u^2(t+u)^6(4s^4+2(4t+u)s^3+3(4t^2+5u^2)s^2+(8t^3 \\
& -2u^3)s+4(t^4-ut^3+6u^2t^2-u^3t+u^4))H(0,0,3,2,y)(s+u)^6+108s^2t^2(s+t)^6u^2(t+u)^6(2s^4+4(t-u)s^3+6(t^2-u^2)s^2+4(t^3 \\
& -u^3)s+2t^4+2u^4+18tu^3-3t^2u^2+18t^3u)H(0,1,0,1,z)(s+u)^6-108s^2t^2(s+t)^6u^2(t+u)^6(2s^4+2(2t+u)s^3+3(2t^2+u^2)s^2 \\
& +2(2t^3+u^3)s+2t^4+2u^4+2tu^3+3t^2u^2+2t^3u)H(0,1,0,2,y)(s+u)^6+432s^2t^2(s+t)^6u^2(t+u)^6(2s^4+2(2t+u)s^3+3(2t^2 \\
& +u^2)s^2+2(2t^3+u^3)s+2t^4+2u^4+2tu^3+3t^2u^2+2t^3u)H(0,1,1,0,y)(s+u)^6+108s^2t^2(s+t)^6u^2(t+u)^6(2s^4+4(t-u)s^3 \\
& +6(t^2+2u^2)s^2+4t^3s+2t^4+2u^4-10tu^3+3t^2u^2-6t^3u)H(0,1,1,0,z)(s+u)^6-108s^2t^2(s+t)^6u^2(t+u)^6(2s^4+2(2t+u)s^3 \\
& +3(2t^2+u^2)s^2+2(2t^3+u^3)s+2t^4+2u^4+2tu^3+3t^2u^2+2t^3u)H(0,1,2,0,y)(s+u)^6+108s^2t^2(s+t)^6u^2(t+u)^6(2s^4 \\
& + (4t-2u)s^3+(6t^2-3u^2)s^2+(4t^3-2u^3)s+2(t^2+ut+u^2)^2)H(0,2,0,2,y)(s+u)^6-216s^2t^2(s+t)^6u^2(t+u)^6(s^4 \\
& +2(t-2u)s^3+3(t^2+u^2)s^2+2(t^3-u^3)s+t^4+u^4+4tu^3+6t^3u)H(0,2,1,0,y)(s+u)^6+108s^2t^2(s+t)^6u^2(t+u)^6(2s^4 \\
& + (4t-2u)s^3+(6t^2-3u^2)s^2+(4t^3-2u^3)s+2(t^2+ut+u^2)^2)H(0,2,2,0,y)(s+u)^6-216s^2t^2(s+t)^6u^2(t+u)^6(s^4 \\
& +2(t-u)s^3+3(t^2+u^2)s^2+2(t^3-2u^3)s+t^4+u^4-4tu^3+9t^2u^2-4t^3u)H(0,2,3,2,y)(s+u)^6-216s^2t^2(s+t)^6u^2(t+u)^6(2s^4 \\
& +2(t+u)s^3+3(t^2+u^2)s^2+2(t^3+u^3)s+2(t^2+ut+u^2)^2)H(0,3,0,2,y)(s+u)^6-216s^2t^2(s+t)^6u^2(t+u)^6(2s^4+2(t+u)s^3 \\
& +3(t^2+u^2)s^2+2(t^3+u^3)s+2(t^2+ut+u^2)^2)H(0,3,2,0,y)(s+u)^6-108s^2t^2(s+t)^6u^2(t+u)^6(4s^4+(6t-2u)s^3+9(t^2 \\
& +u^2)s^2+6(t^3-u^3)s+4(t^2+ut+u^2)^2)H(0,3,2,2,y)(s+u)^6-108s^3t^2(s+t)^6u^2(t+u)^6(2(t+u)s^2+3(t^2-3u^2)s+2(t^3 \\
& +3u^3))H(0,3,3,2,y)(s+u)^6+108s^2t^2(s+t)^6u^2(t+u)^6(2s^4+(4t-6u)s^3+3(2t^2+u^2)s^2+2(2t^3-5u^3)s+2(t^4-2ut^3+6u^2t^2 \\
& +u^4))H(1,0,0,1,z)(s+u)^6-216s^2t^2(s+t)^6u^2(t+u)^6(2s^4+4ts^3+6t^2s^2+4t^3s+2t^4+2u^4+2tu^3+9t^2u^2)H(1,0,0,2,y)(s+u)^6 \\
& +216s^2t^2(s+t)^6u^2(t+u)^6(4s^4+8ts^3+3(4t^2+3u^2)s^2+2(4t^3+u^3)s+4t^4+4u^4+2tu^3+9t^2u^2)H(1,0,1,0,y)(s+u)^6 \\
& +108s^2t^2(s+t)^6u^2(t+u)^6(2s^4+2(2t+9u)s^3+(6t^2-3u^2)s^2+2(2t^3+9u^3)s+2(t^4-2ut^3-3u^2t^2-2u^3t \\
& +u^4))H(1,0,1,0,z)(s+u)^6-216s^2t^2(s+t)^6u^2(t+u)^6(2s^4+4ts^3+6t^2s^2+4t^3s+2t^4+2u^4+2tu^3+9t^2u^2)H(1,0,2,0,y)(s+u)^6 \\
& -216s^2t^2(s+t)^6u^3(t+u)^6(2s^3-3us^2+4u^2s+6t(t^2-ut+u^2))H(1,0,3,2,y)(s+u)^6+216s^2t^2(s+t)^6u^2(t+u)^6(4s^4+8ts^3 \\
& +3(4t^2+3u^2)s^2+2(4t^3+u^3)s+4t^4+4u^4+2tu^3+9t^2u^2)H(1,1,0,0,y)(s+u)^6+108s^2t^2(s+t)^6u^2(t+u)^6(2s^4+4(t+u)s^3 \\
& +6(t^2+u^2)s^2+4(t^3+u^3)s+2t^4+2u^4-2tu^3-3t^2u^2-2t^3u)H(1,1,0,0,z)(s+u)^6-432s^2t^2(s+t)^6u^3(t+u)^6(2s^3 \\
& +3u^2s-3t^3-2tu^2)H(1,1,0,1,z)(s+u)^6-216s^2t^3(s+t)^6u^3(t+u)^6(4t^2-3ut+2u^2)H(1,1,0,2,y)(s+u)^6 \\
& +216s^2t^2(s+t)^6u^2(t+u)^6(4s^4+8(t+u)s^3+3(4t^2+u^2)s^2+(8t^3+6u^3)s+4t^4+4u^4+6tu^3+3t^2u^2+8t^3u)H(1,1,1,0,y)(s+u)^6 \\
& +324s^2t^2(s+t)^6u^3(t+u)^6(4s^3-4us^2+4u^2s-t(2t^2+3ut+2u^2))H(1,1,1,0,z)(s+u)^6-216s^2t^3(s+t)^6u^3(t+u)^6(4t^2-3ut \\
& +2u^2)H(1,1,2,0,y)(s+u)^6-216s^2t^2(s+t)^6u^2(t+u)^6(2s^4+4ts^3+6t^2s^2+4t^3s+2t^4+2u^4+2tu^3+9t^2u^2)H(1,2,0,0,y)(s+u)^6 \\
& -216s^3t^2(s+t)^6u^3(t+u)^6(4s^2-3us+2u^2)H(1,2,1,0,y)(s+u)^6+216s^2t^2(s+t)^6u^3(t+u)^6(2s^3-3us^2+4u^2s+6t(t^2 \\
& -ut+u^2))H(1,2,3,2,y)(s+u)^6+108s^2t^2(s+t)^6u^2(t+u)^6(2s^4+(4t-2u)s^3+(6t^2-3u^2)s^2+(4t^3-2u^3)s+2(t^2 \\
& +ut+u^2)^2)H(2,0,0,2,y)(s+u)^6-216s^2t^2(s+t)^6u^2(t+u)^6(s^4-4(t+u)s^3+3(3t^2+u^2)s^2-2(2t^3+u^3)s+(t^2 \\
& +ut+u^2)^2)H(2,0,1,0,y)(s+u)^6+108s^2t^2(s+t)^6u^2(t+u)^6(2s^4+(4t-2u)s^3+(6t^2-3u^2)s^2+(4t^3-2u^3)s+2(t^2 \\
& +ut+u^2)^2)H(2,0,2,0,y)(s+u)^6-216s^2t^2(s+t)^6u^2(t+u)^6(s^4+(4t-2u)s^3+3u^2s^2+(6t^3-4u^3)s+(t^2+ut \\
& +u^2)^2)H(2,0,3,2,y)(s+u)^6-108s^2t^2(s+t)^6u^2(t+u)^6(4s^4+(8t-6u)s^3+3(4t^2+3u^2)s^2+(8t^3-2u^3)s+4t^4+4u^4+6tu^3 \\
& +9t^2u^2+6t^3u)H(2,1,0,0,y)(s+u)^6-216s^2t^2(s+t)^6u^2(t+u)^6(2s^4+2(2t+u)s^3+3(2t^2+u^2)s^2+2(2t^3+u^3)s+2t^4+2u^4+2tu^3 \\
& +3t^2u^2+2t^3u)H(2,1,0,2,y)(s+u)^6-108s^2t^2(s+t)^6u^3(t+u)^6(6s^3-9us^2+2u^2s+t(2t^2+3ut+2u^2))H(2,1,1,0,y)(s+u)^6 \\
& -216s^2t^2(s+t)^6u^2(t+u)^6(2s^4+2(2t+u)s^3+3(2t^2+u^2)s^2+2(2t^3+u^3)s+2t^4+2u^4+2tu^3+3t^2u^2+2t^3u)H(2,1,2,0,y)(s+u)^6 \\
& +108s^2t^2(s+t)^6u^2(t+u)^6(2s^4+(4t-2u)s^3+(6t^2-3u^2)s^2+(4t^3-2u^3)s+2(t^2+ut+u^2)^2)H(2,2,0,0,y)(s+u)^6
\end{aligned}$$

$$\begin{aligned}
& -108s^2t^2(s+t)^6u^2(t+u)^6(4s^4-2(2t+u)s^3+3(8t^2+5u^2)s^2+(2u^3-4t^3)s+4(t^2+ut+u^2)^2)H(2,2,1,0,y)(s+u)^6 \\
& +432s^2t^2(s+t)^6u^2(t+u)^6(s^4+3(t^2+u^2)s^2-(t^3+u^3)s+(t^2+ut+u^2)^2)H(2,2,3,2,y)(s+u)^6-108s^2t^2(s+t)^6u^2(t+u)^6(2s^4 \\
& +2(t+u)s^3+3(t^2+u^2)s^2+2(t^3+u^3)s+2(t^2+ut+u^2)^2)H(2,3,0,2,y)(s+u)^6-108s^2t^2(s+t)^6u^2(t+u)^6(2s^4+2(t+u)s^3 \\
& +3(t^2+u^2)s^2+2(t^3+u^3)s+2(t^2+ut+u^2)^2)H(2,3,2,0,y)(s+u)^6+432s^2t^2(s+t)^6u^2(t+u)^6(2s^4+2(t+u)s^3+3(t^2 \\
& +u^2)s^2+2(t^3+u^3)s+2(t^2+ut+u^2)^2)H(2,3,3,2,y)(s+u)^6+216s^3t^2(s+t)^6u^2(t+u)^6((6t+4u)s^2-3(2t^2+u^2)s \\
& +2(3t^3+u^3))H(3,0,1,0,y)(s+u)^6-216s^2t^2(s+t)^6u^2(t+u)^6(2s^4+2ts^3+9t^2s^2+2(t^2+ut+u^2)^2)H(3,0,2,2,y)(s+u)^6 \\
& -216s^3t^2(s+t)^6u^3(t+u)^6(2s^2-3us+4u^2)H(3,0,3,2,y)(s+u)^6-216s^2t^2(s+t)^6u^2(t+u)^6(2s^4+2ts^3+9t^2s^2+2(t^2+ut \\
& +u^2)^2)H(3,2,0,2,y)(s+u)^6-216s^3t^2(s+t)^6u^2(t+u)^6((6t+4u)s^2-3(2t^2+u^2)s+2(3t^3+u^3))H(3,2,1,0,y)(s+u)^6 \\
& -216s^2t^2(s+t)^6u^2(t+u)^6(2s^4+2ts^3+9t^2s^2+2(t^2+ut+u^2)^2)H(3,2,2,0,y)(s+u)^6+216s^2t^2(s+t)^6u^2(t+u)^6(4s^4+2(t+u)s^3 \\
& +9(t^2+u^2)s^2+4(t^2+ut+u^2)^2)H(3,2,3,2,y)(s+u)^6-216s^3t^3(s+t)^6(2s^2-3ts+4t^2)u^2(t+u)^6H(3,3,0,2,y)(s+u)^6 \\
& -216s^3t^3(s+t)^6(2s^2-3ts+4t^2)u^2(t+u)^6H(3,3,2,0,y)(s+u)^6+216s^2t^2(s+t)^6u^2(t+u)^6(4s^4+2(t+u)s^3+9(t^2+u^2)s^2 \\
& +4(t^2+ut+u^2)^2)H(3,3,2,2,y)(s+u)^6+216s^2t^2(s+t)^6u^2(t+u)^6(4s^4+6(t+u)s^3+3(t^2+u^2)s^2+8(t^3+u^3)s+4(t^2 \\
& +ut+u^2)^2)H(3,3,3,2,y)(s+u)^6-s^2t^2(s+t)^3u^2(t+u)^3(7948(t+u)^3s^{10}+(39359t^4+155744ut^3+236082u^2t^2+155744u^3t \\
& +39359u^4)s^9+(93651t^5+434331ut^4+850587u^2t^3+850587u^3t^2+434331u^4t+93651u^5)s^8+3(46598t^6+240304ut^5+550627u^2t^4 \\
& +717154u^3t^3+550627u^4t^2+240304u^5t+46598u^6)s^7+(139794t^7+836962ut^6+2146599u^2t^5+3271156u^3t^4+3271156u^4t^3 \\
& +2146599u^5t^2+836962u^6t+139794u^7)s^6+3(31217t^8+240304ut^7+715533u^2t^6+1216094u^3t^5+1422608u^4t^4+1216094u^5t^3 \\
& +715533u^6t^2+240304u^7t+31217u^8)s^5+(39359t^9+434331ut^8+1651881u^2t^7+3271156u^3t^6+4267824u^4t^5+4267824u^5t^4 \\
& +3271156u^6t^3+1651881u^7t^2+434331u^8t+39359u^9)s^4+(7948t^{10}+155744ut^9+850587u^2t^8+2151462u^3t^7+3271156u^4t^6 \\
& +3648282u^5t^5+3271156u^6t^4+2151462u^7t^3+850587u^8t^2+155744u^9t+7948u^{10})s^3+3tu(7948t^9+78694ut^8+283529u^2t^7 \\
& +550627u^3t^6+715533u^4t^5+715533u^5t^4+550627u^6t^3+283529u^7t^2+78694u^8t+7948u^9)s^2+t^2u^2(t+u)^2(23844t^6+108056ut^5 \\
& +194375u^2t^4+224106u^3t^3+194375u^4t^2+108056u^5t+23844u^6)s+ t^3u^3(t+u)^3(7948t^4+15515ut^3+23262u^2t^2+15515u^3t \\
& +7948u^4)(s+u)^3+18s^2t^2u^2((11t^6+162ut^5+153u^2t^4+884u^3t^3+255u^4t^2+246u^5t+33u^6)s^{13}+(62t^7+1339ut^6 \\
& +2160u^2t^5+8525u^3t^4+7390u^4t^3+3807u^5t^2+1728u^6t+189u^7)s^{12}+6(26t^8+774ut^7+1639u^2t^6+5548u^3t^5+7678u^4t^4 \\
& +4900u^5t^3+2621u^6t^2+826u^7t+84u^8)s^{11}+2(140t^9+4728ut^8+12480u^2t^7+37199u^3t^6+69840u^4t^5+60090u^5t^4+36224u^6t^3 \\
& +17091u^7t^2+4188u^8t+404u^9)s^{10}+(534t^{10}+13578ut^9+45012u^2t^8+119424u^3t^7+270061u^4t^6+311178u^5t^5+220301u^6t^4 \\
& +125964u^7t^3+47997u^8t^2+9560u^9t+839u^{10})s^9+3(340t^{11}+5526ut^{10}+22370u^2t^9+55138u^3t^8+129254u^4t^7+190253u^5t^6 \\
& +166896u^6t^5+109793u^7t^4+53466u^8t^3+15573u^9t^2+2466u^{10}t+189u^{11})s^8+2(736t^{12}+9471ut^{11}+44292u^2t^{10}+110988u^3t^9 \\
& +235059u^4t^8+387831u^5t^7+413404u^6t^6+317445u^7t^5+187035u^8t^4+72214u^9t^3+15774u^{10}t^2+1827u^{11}t+116u^{12})s^7 \\
& +2(708t^{13}+9054ut^{12}+47823u^2t^{11}+134712u^3t^{10}+269098u^4t^9+435561u^5t^8+508839u^6t^7+430834u^7t^6+288621u^8t^5 \\
& +141397u^9t^4+43186u^{10}t^3+7236u^{11}t^2+541u^{12}t+22u^{13})s^6+3t(285t^{13}+4132ut^{12}+24795u^2t^{11}+81510u^3t^{10}+175113u^4t^9 \\
& +286188u^5t^8+351323u^6t^7+311558u^7t^6+211822u^8t^5+112744u^9t^4+42788u^{10}t^3+10552u^{11}t^2+1454u^{12}t+56u^{13})s^5 \\
& +t^2(294t^{13}+5499ut^{12}+38730u^2t^{11}+148723u^3t^{10}+362736u^4t^9+642597u^5t^8+864762u^6t^7+853029u^7t^6+614934u^8t^5 \\
& +328490u^9t^4+124788u^{10}t^3+32430u^{11}t^2+6072u^{12}t+708u^{13})s^4+2t^3(22t^{13}+707ut^{12}+6399u^2t^{11}+29412u^3t^{10}+82842u^4t^9 \\
& +162087u^5t^8+239183u^6t^7+267073u^7t^6+222465u^8t^5+137118u^9t^4+59592u^{10}t^3+16485u^{11}t^2+2553u^{12}t+174u^{13})s^3 \\
& +6t^4u(t+u)^2(26t^{10}+335ut^9+1643u^2t^8+4383u^3t^7+7465u^4t^6+9430u^5t^5+8350u^6t^4+5555u^7t^3+2649u^8t^2+809u^9t+127u^{10})s^2
\end{aligned}$$



$$\begin{aligned}
& + t^5 u^2 (t+u)^3 (162t^8 + 1164ut^7 + 3573u^2t^6 + 6255u^3t^5 + 7589u^4t^4 + 5865u^5t^3 + 3192u^6t^2 + 1112u^7t + 216u^8) s + t^6 u^3 (t+u)^6 (58t^4 \\
& + 100ut^3 + 153u^2t^2 + 100u^3t + 58u^4) H(2, y)H(1, 0, z) (s+u)^3 + st(s+t)^2 u^2 (t+u)^2 (1531t(t+u)^4 s^{13} + 3(3029t^6 + 15191ut^5 \\
& + 28746u^2t^4 + 30440u^3t^3 + 14567u^4t^2 + 3351u^5t + 120u^6) s^{12} + (25433t^7 + 151345u^6 + 347338u^2t^5 + 471508u^3t^4 + 364546u^4t^3 \\
& + 144937u^5t^2 + 32273u^6t + 1800u^7) s^{11} + (44445t^8 + 300713ut^7 + 814816u^2t^6 + 1300511u^3t^5 + 1362455u^4t^4 + 833113u^5t^3 \\
& + 303956u^6t^2 + 65055u^7t + 3960u^8) s^{10} + (53136t^9 + 409309ut^8 + 1281415u^2t^7 + 2291071u^3t^6 + 2894942u^4t^5 + 2471851u^5t^4 \\
& + 1320295u^6t^3 + 459769u^7t^2 + 87252u^8t + 5040u^9) s^9 + (44445t^{10} + 409309ut^9 + 1473770u^2t^8 + 2915618u^3t^7 + 4102638u^4t^6 \\
& + 4464012u^5t^5 + 3318386u^6t^4 + 1630106u^7t^3 + 508285u^8t^2 + 77799u^9t + 3960u^{10}) s^8 + (25433t^{11} + 300713u^2t^{10} + 1281415u^2t^9 \\
& + 2915618u^3t^8 + 4495118u^4t^7 + 5664674u^5t^6 + 5440250u^6t^5 + 3552410u^7t^4 + 1539427u^8t^3 + 391013u^9t^2 + 44585u^{10}t + 1800u^{11}) s^7 \\
& + (9087t^{12} + 151345ut^{11} + 814816u^2t^{10} + 2291071u^3t^9 + 4102638u^4t^8 + 5664674u^5t^7 + 6338504u^6t^6 + 5147724u^7t^5 + 2865079u^8t^4 \\
& + 1027309u^9t^3 + 196900u^{10}t^2 + 15021u^{11}t + 360u^{12}) s^6 + (1531t^{12} + 45573ut^{11} + 347338u^2t^{10} + 1300511u^3t^9 + 2894942u^4t^8 \\
& + 4464012u^5t^7 + 5440250u^6t^6 + 5147724u^7t^5 + 3498698u^8t^4 + 1616591u^9t^3 + 448090u^{10}t^2 + 58725u^{11}t + 2287u^{12}) s^5 + t^2 u (6124t^{11} \\
& + 86238u^2t^{10} + 471508u^2t^9 + 1362455u^3t^8 + 2471851u^4t^7 + 3318386u^5t^6 + 3552410u^6t^5 + 2865079u^7t^4 + 1616591u^8t^3 + 581902u^9t^2 \\
& + 110862u^{10}t + 7726u^{11}) s^4 + t^3 u^2 (9186t^{10} + 91320ut^9 + 364546u^2t^8 + 833113u^3t^7 + 1320295u^4t^6 + 1630106u^5t^5 + 1539427u^6t^4 \\
& + 1027309u^7t^3 + 448090u^8t^2 + 110862u^9t + 11166u^{10}) s^3 + t^4 u^3 (t+u)^2 (6124t^7 + 31453u^6 + 75907u^2t^5 + 120689u^3t^4 + 142484u^4t^3 \\
& + 102628u^5t^2 + 43273u^6t + 7726u^7) s^2 + t^5 u^4 (t+u)^4 (1531t^4 + 3929ut^3 + 7371u^2t^2 + 5873u^3t + 2287u^4) s + 360t^6 u^6 (t+u)^4 (t^2 \\
& + ut + u^2) H(0, y)(s+u)^2 + st^2(s+t)^2 u (t+u)^2 (1531u(t+u)^4 s^{13} + 3(120t^6 + 3351ut^5 + 14567u^2t^4 + 30440u^3t^3 + 28746u^4t^2 \\
& + 15191u^5t + 3029u^6) s^{12} + (1800t^7 + 32273ut^6 + 144937u^2t^5 + 364546u^3t^4 + 471508u^4t^3 + 347338u^5t^2 + 151345u^6t + 25433u^7) s^{11} \\
& + (3960t^8 + 65055ut^7 + 303956u^2t^6 + 833113u^3t^5 + 1362455u^4t^4 + 1300511u^5t^3 + 814816u^6t^2 + 300713u^7t + 44445u^8) s^{10} \\
& + (5040t^9 + 87252u^2t^8 + 459769u^2t^7 + 1320295u^3t^6 + 2471851u^4t^5 + 2894942u^5t^4 + 2291071u^6t^3 + 1281415u^7t^2 + 409309u^8t \\
& + 53136u^9) s^9 + (3960t^{10} + 77799ut^9 + 508285u^2t^8 + 1630106u^3t^7 + 3318386u^4t^6 + 4464012u^5t^5 + 4102638u^6t^4 + 2915618u^7t^3 \\
& + 1473770u^8t^2 + 409309u^9t + 44445u^{10}) s^8 + (1800t^{11} + 44585ut^{10} + 391013u^2t^9 + 1539427u^3t^8 + 3552410u^4t^7 + 5440250u^5t^6 \\
& + 5664674u^6t^5 + 4495118u^7t^4 + 2915618u^8t^3 + 1281415u^9t^2 + 300713u^{10}t + 25433u^{11}) s^7 + (360t^{12} + 15021ut^{11} + 196900u^2t^{10} \\
& + 1027309u^3t^9 + 2865079u^4t^8 + 5147724u^5t^7 + 6338504u^6t^6 + 5664674u^7t^5 + 4102638u^8t^4 + 2291071u^9t^3 + 814816u^{10}t^2 \\
& + 151345u^{11}t + 9087u^{12}) s^6 + u(2287t^{12} + 58725ut^{11} + 448090u^2t^{10} + 1616591u^3t^9 + 3498698u^4t^8 + 5147724u^5t^7 + 5440250u^6t^6 \\
& + 4464012u^7t^5 + 2894942u^8t^4 + 1300511u^9t^3 + 347338u^{10}t^2 + 45573u^{11}t + 1531u^{12}) s^5 + tu^2(7726t^{11} + 110862ut^{10} + 581902u^2t^9 \\
& + 1616591u^3t^8 + 2865079u^4t^7 + 3552410u^5t^6 + 3318386u^6t^5 + 2471851u^7t^4 + 1362455u^8t^3 + 471508u^9t^2 + 86238u^{10}t + 6124u^{11}) s^4 \\
& + t^2 u^3 (11166t^{10} + 110862ut^9 + 448090u^2t^8 + 1027309u^3t^7 + 1539427u^4t^6 + 1630106u^5t^5 + 1320295u^6t^4 + 833113u^7t^3 + 364546u^8t^2 \\
& + 91320u^9t + 9186u^{10}) s^3 + t^3 u^4 (t+u)^2 (7726t^7 + 43273ut^6 + 102628u^2t^5 + 142484u^3t^4 + 120689u^4t^3 + 75907u^5t^2 + 31453u^6t \\
& + 6124u^7) s^2 + t^4 u^5 (t+u)^4 (2287t^4 + 5873ut^3 + 7371u^2t^2 + 3929u^3t + 1531u^4) s + 360t^6 u^6 (t+u)^4 (t^2 + ut + u^2) H(0, z)(s+u)^2 \\
& + 3t^2(s+t)^2 u^2 (t+u) (259(t+u)^5 s^{14} + 36(43t^6 + 242ut^5 + 651u^2t^4 + 764u^3t^3 + 651u^4t^2 + 242u^5t + 43u^6) s^{13} + (4367t^7 + 26163ut^6 \\
& + 84905u^2t^5 + 124733u^3t^4 + 124733u^4t^3 + 84905u^5t^2 + 26163u^6t + 4367u^7) s^{12} + 4(1920t^8 + 12056ut^7 + 43065u^2t^6 + 78684u^3t^5 \\
& + 86470u^4t^4 + 78684u^5t^3 + 43065u^6t^2 + 12056u^7t + 1920u^8) s^{11} + 6(1534t^9 + 10415ut^8 + 38108u^2t^7 + 83108u^3t^6 + 101419u^4t^5 \\
& + 101419u^5t^4 + 83108u^6t^3 + 38108u^7t^2 + 10415u^8t + 1534u^9) s^{10} + 12(640t^{10} + 4992ut^9 + 18355u^2t^8 + 44658u^3t^7 + 62385u^4t^6 \\
& + 60940u^5t^5 + 62385u^6t^4 + 44658u^7t^3 + 18355u^8t^2 + 4992u^9t + 640u^{10}) s^9 + (4367t^{11} + 41875u^2t^{10} + 163877u^2t^9 + 417437u^3t^8 \\
& + 677572u^4t^7 + 645896u^5t^6 + 645896u^6t^5 + 677572u^7t^4 + 417437u^8t^3 + 163877u^9t^2 + 41875u^{10}t + 4367u^{11}) s^8 + 2(774t^{12} \\
& + 9924ut^{11} + 46320u^2t^{10} + 124333u^3t^9 + 232260u^4t^8 + 249279u^5t^7 + 198284u^6t^6 + 249279u^7t^5 + 232260u^8t^4 + 124333u^9t^3 \\
& + 46320u^{10}t^2 + 9924u^{11}t + 774u^{12}) s^7 + (259t^{13} + 5481ut^{12} + 35278u^2t^{11} + 110676u^3t^{10} + 240564u^4t^9 + 349066u^5t^8 + 300068u^6t^7 \\
& + 300068u^7t^6 + 349066u^8t^5 + 240564u^9t^4 + 110676u^{10}t^3 + 35278u^{11}t^2 + 5481u^{12}t + 259u^{13}) s^6 + 2tu(308t^{12} + 3564ut^{11} + 15365u^2t^{10} \\
& + 42591u^3t^9 + 94706u^4t^8 + 136033u^5t^7 + 141098u^6t^6 + 136033u^7t^5 + 94706u^8t^4 + 42591u^9t^3 + 15365u^{10}t^2 + 3564u^{11}t + 308u^{12}) s^5 \\
& + t^2 u^2 (426t^{11} + 3380ut^{10} + 15835u^2t^9 + 65921u^3t^8 + 171209u^4t^7 + 259557u^5t^6 + 259557u^6t^5 + 171209u^7t^4 + 65921u^8t^3 + 15835u^9t^2 \\
& + 3380u^{10}t + 426u^{11}) s^4 - 2t^3 u^3 (t+u)^2 (34t^8 - 527u^7t - 6013u^2t^6 - 19815u^3t^5 - 26374u^4t^4 - 19815u^5t^3 - 6013u^6t^2 - 527u^7t \\
& + 34u^8) s^3 + t^4 u^4 (t+u)^3 (109t^6 + 2242ut^5 + 8867u^2t^4 + 13216u^3t^3 + 8867u^4t^2 + 2242u^5t + 109u^6) s^2 + 30t^5 u^5 (t+u)^6 (10t^2 \\
& + 23ut + 10u^2) s + 120t^6 u^6 (t+u)^5 (t^2 + ut + u^2) H(0, y)H(0, z)(s+u)^2 - s^2 t(s+t)^2 u(t+u)^2 ((360t^6 + 2287ut^5 + 7726u^2t^4 \\
& + 11166u^3t^3 + 7726u^4t^2 + 2287u^5t + 360u^6) s^{12} + 9(200t^7 + 1669ut^6 + 6525u^2t^5 + 12318u^3t^4 + 12318u^4t^3 + 6525u^5t^2 + 1669u^6t \\
& + 200u^7) s^{11} + (3960t^8 + 44585ut^7 + 196900u^2t^6 + 448090u^3t^5 + 581902u^4t^4 + 448090u^5t^3 + 196900u^6t^2 + 44585u^7t + 3960u^8) s^{10}
\end{aligned}$$

$$\begin{aligned}
& + \left( 5040t^9 + 77799ut^8 + 391013u^2t^7 + 1027309u^3t^6 + 1616591u^4t^5 + 1616591u^5t^4 + 1027309u^6t^3 + 391013u^7t^2 + 77799u^8t \right. \\
& + 5040u^9 \left. \right) s^9 + \left( 3960t^{10} + 87252ut^9 + 508285u^2t^8 + 1539427u^3t^7 + 2865079u^4t^6 + 3498698u^5t^5 + 2865079u^6t^4 + 1539427u^7t^3 \right. \\
& + 508285u^8t^2 + 87252u^9t + 3960u^{10} \left. \right) s^8 + \left( 1800t^{11} + 65055ut^{10} + 459769u^2t^9 + 1630106u^3t^8 + 3552410u^4t^7 + 5147724u^5t^6 \right. \\
& + 5147724u^6t^5 + 3552410u^7t^4 + 1630106u^8t^3 + 459769u^9t^2 + 65055u^{10}t + 1800u^{11} \left. \right) s^7 + \left( 360t^{12} + 32273ut^{11} + 303956u^2t^{10} \right. \\
& + 1320295u^3t^9 + 3318386u^4t^8 + 5440250u^5t^7 + 6338504u^6t^6 + 5440250u^7t^5 + 3318386u^8t^4 + 1320295u^9t^3 + 303956u^{10}t^2 + 32273u^{11}t \\
& + 360u^{12} \left. \right) s^6 + tu \left( 10053t^{11} + 144937ut^{10} + 833113u^2t^9 + 2471851u^3t^8 + 4464012u^4t^7 + 5664674u^5t^6 + 5664674u^6t^5 + 4464012u^7t^4 \right. \\
& + 2471851u^8t^3 + 833113u^9t^2 + 144937u^{10}t + 10053u^{11} \left. \right) s^5 + tu \left( 1531t^{12} + 43701ut^{11} + 364546u^2t^{10} + 1362455u^3t^9 + 2894942u^4t^8 \right. \\
& + 4102638u^5t^7 + 4495118u^6t^6 + 4102638u^7t^5 + 2894942u^8t^4 + 1362455u^9t^3 + 364546u^{10}t^2 + 43701u^{11}t + 1531u^{12} \left. \right) s^4 + t^2u^2 \left( 6124t^{11} \right. \\
& + 91320u^{10}t^9 + 471508u^9t^8 + 1300511u^8t^7 + 2291071u^7t^6 + 2915618u^6t^5 + 2915618u^5t^4 + 2291071u^4t^3 + 1300511u^3t^2 + 471508u^2t \\
& + 91320u^{10}t^9 + 6124u^{11} \left. \right) s^3 + t^3u^3(t+u)^2 \left( 9186t^8 + 67866ut^7 + 202420u^2t^6 + 342110u^3t^5 + 394775u^4t^4 + 342110u^5t^3 + 202420u^6t^2 \right. \\
& + 67866u^7t + 9186u^8 \left. \right) s^2 + t^4u^4(t+u)^3 \left( 6124t^6 + 27201ut^5 + 51370u^2t^4 + 58876u^3t^3 + 51370u^4t^2 + 27201u^5t + 6124u^6 \right) s \\
& + t^5u^5(t+u)^4 \left( 1531t^4 + 2963ut^3 + 4395u^2t^2 + 2963u^3t + 1531u^4 \right) H(1, z)(s+u)^2 - s^2t(s+t)^2u(t+u)^2 \left( (360t^6 + 2287ut^5 \right. \\
& + 7726u^2t^4 + 11166u^3t^3 + 7726u^4t^2 + 2287u^5t + 360u^6) s^{12} + 9(200t^7 + 1669ut^6 + 6525u^2t^5 + 12318u^3t^4 + 12318u^4t^3 + 6525u^5t^2 \\
& + 1669u^6t + 200u^7) s^{11} + (3960t^8 + 44585ut^7 + 196900u^2t^6 + 448090u^3t^5 + 581902u^4t^4 + 448090u^5t^3 + 196900u^6t^2 + 44585u^7t \\
& + 3960u^8) s^{10} + (5040t^9 + 77799ut^8 + 391013u^2t^7 + 1027309u^3t^6 + 1616591u^4t^5 + 1616591u^5t^4 + 1027309u^6t^3 + 391013u^7t^2 \\
& + 77799u^8t + 5040u^9) s^9 + (3960t^{10} + 87252ut^9 + 508285u^2t^8 + 1539427u^3t^7 + 2865079u^4t^6 + 3498698u^5t^5 + 2865079u^6t^4 \\
& + 1539427u^7t^3 + 508285u^8t^2 + 87252u^9t + 3960u^{10}) s^8 + (1800t^{11} + 65055ut^{10} + 459769u^2t^9 + 1630106u^3t^8 + 3552410u^4t^7 \\
& + 5147724u^5t^6 + 5147724u^6t^5 + 3552410u^7t^4 + 1630106u^8t^3 + 459769u^9t^2 + 65055u^{10}t + 1800u^{11}) s^7 + (360t^{12} + 32273ut^{11} \\
& + 303956u^2t^{10} + 1320295u^3t^9 + 3318386u^4t^8 + 5440250u^5t^7 + 6338504u^6t^6 + 5440250u^7t^5 + 3318386u^8t^4 + 1320295u^9t^3 \\
& + 303956u^{10}t^2 + 32273u^{11}t + 360u^{12}) s^6 + tu \left( 10053t^{11} + 144937ut^{10} + 833113u^2t^9 + 2471851u^3t^8 + 4464012u^4t^7 + 5664674u^5t^6 \right. \\
& + 5664674u^6t^5 + 4464012u^7t^4 + 2471851u^8t^3 + 833113u^9t^2 + 144937u^{10}t + 10053u^{11} \left. \right) s^5 + tu \left( 1531t^{12} + 43701ut^{11} + 364546u^2t^{10} \right. \\
& + 1362455u^3t^9 + 2894942u^4t^8 + 4102638u^5t^7 + 4495118u^6t^6 + 4102638u^7t^5 + 2894942u^8t^4 + 1362455u^9t^3 + 364546u^{10}t^2 \\
& + 43701u^{11}t + 1531u^{12} \left. \right) s^4 + t^2u^2 \left( 6124t^{11} + 91320u^{10}t^9 + 471508u^9t^8 + 1300511u^8t^7 + 2291071u^7t^6 + 2915618u^6t^5 + 2915618u^5t^4 \right. \\
& + 2291071u^4t^3 + 1300511u^3t^2 + 471508u^2t + 91320u^{10}t^9 + 6124u^{11} \left. \right) s^3 + t^3u^3(t+u)^2 \left( 9186t^8 + 67866ut^7 + 202420u^2t^6 \right. \\
& + 342110u^3t^5 + 394775u^4t^4 + 342110u^5t^3 + 202420u^6t^2 + 67866u^7t + 9186u^8 \left. \right) s^2 + t^4u^4(t+u)^3 \left( 6124t^6 + 27201ut^5 + 51370u^2t^4 \right. \\
& + 58876u^3t^3 + 51370u^4t^2 + 27201u^5t + 6124u^6 \left. \right) s + t^5u^5(t+u)^4 \left( 1531t^4 + 2963ut^3 + 4395u^2t^2 + 2963u^3t + 1531u^4 \right) H(2, y)(s+u)^2 \\
& - 3s^2t^2(t+u)^2 \left( (120t^6 + 300ut^5 + 109u^2t^4 - 68u^3t^3 + 426u^4t^2 + 616u^5t + 259u^6) s^{14} + 2(420t^7 + 1395ut^6 + 1339u^2t^5 + 425u^3t^4 \right. \\
& + 1903u^4t^3 + 3872u^5t^2 + 2870u^6t + 774u^7) s^{13} + (2640t^8 + 11430ut^7 + 18489u^2t^6 + 14984u^3t^5 + 19215u^4t^4 + 37858u^5t^3 + 40759u^6t^2 \\
& + 21396u^7t + 4367u^8) s^{12} + 2(2460t^9 + 13545ut^8 + 31286u^2t^7 + 39401u^3t^6 + 40878u^4t^5 + 57956u^5t^4 + 72977u^6t^3 + 56244u^7t^2 \\
& + 23121u^8t + 3840u^9) s^{11} + 2(3000t^{10} + 20475ut^9 + 62005u^2t^8 + 104385u^3t^7 + 118565u^4t^6 + 137297u^5t^5 + 175620u^6t^4 + 170653u^7t^3 \\
& + 102876u^8t^2 + 33792u^9t + 4602u^{10}) s^{10} + 2(2460t^{11} + 20475ut^{10} + 77358u^2t^9 + 164395u^3t^8 + 215383u^4t^7 + 230739u^5t^6 \\
& + 294815u^6t^5 + 356593u^7t^4 + 290657u^8t^3 + 140082u^9t^2 + 35847u^{10}t + 3840u^{11}) s^9 + (2640t^{12} + 27090ut^{11} + 124010u^2t^{10} \\
& + 328790u^3t^9 + 519114u^4t^8 + 554262u^5t^7 + 649134u^6t^6 + 963078u^7t^5 + 1095009u^8t^4 + 756156u^9t^3 + 291138u^{10}t^2 + 55904u^{11}t \\
& + 4367u^{12}) s^8 + 2(420t^{13} + 5715ut^{12} + 31286u^2t^{11} + 104385u^3t^{10} + 215383u^4t^9 + 277131u^5t^8 + 300068u^6t^7 + 447563u^7t^6 \\
& + 661734u^8t^5 + 642258u^9t^4 + 363648u^{10}t^3 + 110242u^{11}t^2 + 15265u^{12}t + 774u^{13}) s^7 + (120t^{14} + 2790ut^{13} + 18489u^2t^{12} + 78802u^3t^{11} \\
& + 237130u^4t^{10} + 461478u^5t^9 + 649134u^6t^8 + 895126u^7t^7 + 1291792u^8t^6 + 1479900u^9t^5 + 1107162u^{10}t^4 + 486996u^{11}t^3 + 111068u^{12}t^2 \\
& + 10260u^{13}t + 259u^{14}) s^6 + 2tu \left( 150t^{13} + 1339ut^{12} + 7492u^2t^{11} + 40878u^3t^{10} + 137297u^4t^9 + 294815u^5t^8 + 481539u^6t^7 + 661734u^7t^6 \right. \\
& + 739950u^8t^5 + 608514u^9t^4 + 330308u^{10}t^3 + 104819u^{11}t^2 + 16074u^{12}t + 777u^{13} \left. \right) s^5 + t^2u^2 \left( 109t^{12} + 850ut^{11} + 19215u^2t^{10} \right. \\
& + 115912u^3t^9 + 351240u^4t^8 + 713186u^5t^7 + 1095009u^6t^6 + 1284516u^7t^5 + 1107162u^8t^4 + 660616u^9t^3 + 249466u^{10}t^2 + 50940u^{11}t \\
& + 3885u^{12} \left. \right) s^4 + 2t^3u^3 \left( -34t^{11} + 1903ut^{10} + 18929u^2t^9 + 72977u^3t^8 + 170653u^4t^7 + 290657u^5t^6 + 378078u^6t^5 + 363648u^7t^4 \right. \\
& + 243498u^8t^3 + 104819u^9t^2 + 25470u^{10}t + 2590u^{11} \left. \right) s^3 + t^4u^4(t+u)^2 \left( 426t^8 + 6892ut^7 + 26549u^2t^6 + 52498u^3t^5 + 74207u^4t^4 \right. \\
& + 79252u^5t^3 + 58427u^6t^2 + 24378u^7t + 3885u^8 \left. \right) s^2 + 2t^5u^5(t+u)^3 \left( 308t^6 + 1946ut^5 + 3936u^2t^4 + 5167u^3t^3 + 4537u^4t^2 + 2799u^5t \right. \\
& + 777u^6 \left. \right) s + t^6u^6(t+u)^4 \left( 259t^4 + 512ut^3 + 765u^2t^2 + 512u^3t + 259u^4 \right) H(0, z)H(2, y)(s+u)^2 + 3s^2t^2(s+t)^6u^2(t+u)^6 \left( 363s^8 \right. \\
& + 726(t+3u)s^7 + 3(363t^2 + 796ut + 2057u^2) s^6 + 6(121t^3 + 348ut^2 + 480u^2t + 1815u^3) s^5 + (363t^4 + 958ut^3 - 297u^2t^2 + 1782u^3t \\
& + 13068u^4) s^4 + 2u(246t^4 - 58ut^3 - 1296u^2t^2 + 891u^3t + 5445u^4) s^3 + u^2(504t^4 - 116ut^3 - 297u^2t^2 + 2880u^3t + 6171u^4) s^2
\end{aligned}$$

$$\begin{aligned}
& + 2u^3(246t^4 + 479ut^3 + 1044u^2t^2 + 1194u^3t + 1089u^4)s + 363u^4(t^2 + ut + u^2)^2 H(0, 0, z)(s + u)^2 + 36s^2t^2(s + t)^6 u^2(t + u)^6 (22s^8 \\
& + 44(t + 3u)s^7 + 2(33t^2 + 70ut + 187u^2)s^6 + (44t^3 + 246ut^2 + 147u^2t + 660u^3)s^5 + (22t^4 + 115ut^3 + 360u^2t^2 + 41u^3t + 792u^4)s^4 \\
& + u(64t^4 + 95ut^3 + 246u^2t^2 + 2u^3t + 660u^4)s^3 + u^2(84t^4 + 9ut^3 + 84u^2t^2 + 54u^3t + 374u^4)s^2 + u^3(54t^4 - 11u^3t + 36u^2t^2 + 63u^3t \\
& + 132u^4)s + u^4(18t^4 + 4ut^3 + 18u^2t^2 + 21u^3t + 22u^4) H(0, y)H(0, 0, z)(s + u)^2 - 36s^2t^2(s + t)^6 u^2(t + u)^6 (22s^8 + 3(7t + 44u)s^7 \\
& + (18t^2 + 63ut + 374u^2)s^6 + (4t^3 + 36ut^2 + 54u^2t + 660u^3)s^5 + (18t^4 - 11u^3t + 84u^2t^2 + 2u^3t + 792u^4)s^4 + u(54t^4 + 9u^3t \\
& + 246u^2t^2 + 41u^3t + 660u^4)s^3 + u^2(84t^4 + 95ut^3 + 360u^2t^2 + 147u^3t + 374u^4)s^2 + u^3(64t^4 + 115ut^3 + 246u^2t^2 + 140u^3t + 132u^4)s \\
& + 22u^4(t^2 + ut + u^2)^2 H(2, y)H(0, 0, z)(s + u)^2 + 18s^2t^2u^2(t + u)^2((25t^4 + 64ut^3 + 78u^2t^2 + 44u^3t + 11u^4)s^4 + 2(92t^5 + 278ut^4 \\
& + 393u^2t^3 + 307u^3t^2 + 133u^4t + 27u^5)s^3 + (633t^6 + 2332ut^5 + 3918u^2t^4 + 3896u^3t^3 + 2351u^4t^2 + 816u^5t + 124u^6)s^2 + 2(684t^7 \\
& + 2970ut^6 + 5715u^2t^5 + 6827u^3t^4 + 5495u^4t^3 + 2871u^5t^2 + 846u^6t + 96u^7)s^1 + (2094t^8 + 10548ut^7 + 21762u^2t^6 + 27160u^3t^5 \\
& + 25897u^4t^4 + 19800u^5t^3 + 10356u^6t^2 + 2820u^7t + 231u^8)s^0 + 2(1200t^9 + 6984ut^8 + 15768u^2t^7 + 19041u^3t^6 + 16319u^4t^5 \\
& + 14613u^5t^4 + 13072u^6t^3 + 7593u^7t^2 + 2013u^8t + 105u^9)s^9 + (2094t^{10} + 13968ut^9 + 35988u^2t^8 + 47158u^3t^7 + 37273u^4t^6 \\
& + 27528u^5t^5 + 31140u^6t^4 + 31554u^7t^3 + 17931u^8t^2 + 4336u^9t + 130u^{10})s^8 + 2(684t^{11} + 5274ut^{10} + 15768u^2t^9 + 23579u^3t^8 \\
& + 22058u^4t^7 + 21537u^5t^6 + 26874u^6t^5 + 27399u^7t^4 + 18504u^8t^3 + 7571u^9t^2 + 1472u^{10}t + 24u^{11})s^7 + (633t^{12} + 5940ut^{11} \\
& + 21762u^2t^{10} + 38082u^3t^9 + 37273u^4t^8 + 43074u^5t^7 + 83288u^6t^6 + 111834u^7t^5 + 83094u^8t^4 + 33834u^9t^3 + 7744u^{10}t^2 + 1056u^{11}t \\
& + 8u^{12})s^6 + 2t(92t^{12} + 1166ut^{11} + 5715u^2t^{10} + 13580u^3t^9 + 16319u^4t^8 + 13764u^5t^7 + 26874u^6t^6 + 55917u^7t^5 + 62742u^8t^4 \\
& + 36199u^9t^3 + 9748u^{10}t^2 + 930u^{11}t + 72u^{12})s^5 + t^2(25t^{12} + 556ut^{11} + 3918u^2t^{10} + 13654u^3t^9 + 25897u^4t^8 + 29226u^5t^7 \\
& + 31140u^6t^6 + 54798u^7t^5 + 83094u^8t^4 + 72398u^9t^3 + 32492u^{10}t^2 + 6012u^{11}t + 84u^{12})s^4 + 2t^3u(32t^{11} + 393ut^{10} + 1948u^2t^9 \\
& + 5495u^3t^8 + 9900u^4t^7 + 13072u^5t^6 + 15777u^6t^5 + 18504u^7t^4 + 16917u^8t^3 + 9748u^9t^2 + 3006u^{10}t + 368u^{11})s^3 + t^4u^2(t + u)^2(78t^8 \\
& + 458ut^7 + 1357u^2t^6 + 2570u^3t^5 + 3859u^4t^4 + 4898u^5t^3 + 4276u^6t^2 + 1692u^7t + 84u^8)s^2 + 2t^5u^3(t + u)^3(22t^6 + 67ut^5 + 141u^2t^4 \\
& + 200u^3t^3 + 320u^4t^2 + 312u^5t + 72u^6)s + t^6u^4(t + u)^4(11t^4 + 10u^3t + 18u^2t^2 + 16u^3t + 8u^4) H(0, z)H(0, 2, y)(s + u)^2 \\
& + 3t^2(s + t)u^2((17t^6 + 1338ut^5 + 1209u^2t^4 + 3688u^3t^3 + 4269u^4t^2 + 762u^5t + 293u^6)s^15 + (t + u)^2(125t^5 + 9282ut^4 - 1574u^2t^3 \\
& + 24402u^3t^2 + 2031u^4t + 1740u^5)s^14 + (421t^8 + 28668ut^7 + 79874u^2t^6 + 122578u^3t^5 + 210974u^4t^4 + 216624u^5t^3 + 90402u^6t^2 \\
& + 18674u^7t + 4873u^8)s^13 + (t + u)^2(853t^7 + 47050u^6t^6 + 99979u^2t^5 + 64212u^3t^4 + 244839u^4t^3 + 99258u^5t^2 + 22313u^6t + 8520u^7)s^12 \\
& + 4(288t^{10} + 12551ut^9 + 71057u^2t^8 + 139212u^3t^7 + 179702u^4t^6 + 266064u^5t^5 + 276429u^6t^4 + 139626u^7t^3 + 41347u^8t^2 + 13917u^9t \\
& + 2547u^{10})s^11 + 2(t + u)^2(546t^9 + 13510ut^8 + 92097u^2t^7 + 124154u^3t^6 + 79909u^4t^5 + 282798u^5t^4 + 136349u^6t^3 + 25806u^7t^2 \\
& + 17949u^8t + 4260u^9)s^10 + (745t^{12} + 5476u^2t^{11} + 88790u^2t^{10} + 380158u^3t^9 + 559919u^4t^8 + 624124u^5t^7 + 1280316u^6t^6 + 1630684u^7t^5 \\
& + 908135u^8t^4 + 264280u^9t^3 + 94614u^{10}t^2 + 32670u^{11}t + 4873u^{12})s^9 + (t + u)^2(361t^{11} - 5942ut^{10} - 13109u^2t^9 + 45310u^3t^8 \\
& - 83270u^4t^7 - 225424u^5t^6 + 359776u^6t^5 + 341850u^7t^4 + 131133u^8t^3 + 49098u^9t^2 + 8565u^{10}t + 1740u^{11})s^8 + (113t^{14} - 5422ut^{13} \\
& - 49927u^2t^{12} - 155092u^3t^{11} - 318038u^4t^{10} - 778482u^5t^9 - 1327656u^6t^8 - 974758u^7t^7 - 19040u^8t^6 + 432306u^9t^5 + 380872u^{10}t^4 \\
& + 185882u^{11}t^3 + 39939u^{12}t^2 + 2122u^{13}t + 293u^{14})s^7 + t(t + u)^2(17t^{12} - 2466ut^{11} - 25660u^2t^{10} - 88158u^3t^9 - 136236u^4t^8 \\
& - 237708u^5t^7 - 370210u^6t^6 - 209898u^7t^5 - 117978u^8t^4 - 9304u^9t^3 + 43600u^{10}t^2 + 14262u^{11}t + 49u^{12})s^6 - t^2u(424t^{13} + 9046ut^{12} \\
& + 64296u^2t^{11} + 209881u^3t^{10} + 368916u^4t^9 + 405336u^5t^8 + 306108u^6t^7 + 185900u^7t^6 + 201510u^8t^5 + 255266u^9t^4 + 158896u^{10}t^3 \\
& + 31479u^{11}t^2 - 5494u^{12}t - 2252u^{13})s^5 - t^3u^2(t + u)^2(1038t^{10} + 11826ut^9 + 41953u^2t^8 + 50370u^3t^7 - 10747u^4t^6 - 92766u^5t^5 \\
& - 113853u^6t^4 - 35658u^7t^3 + 15137u^8t^2 + 11676u^9t + 2344u^{10})s^4 - t^4u^3(t + u)^3(1108t^8 + 5303ut^7 + 2515u^2t^6 - 23685u^3t^5 \\
& - 48783u^4t^4 - 46581u^5t^3 - 17785u^6t^2 - 2753u^7t - 67u^8)s^3 - t^5u^4(t + u)^4(133t^6 - 1574ut^5 - 8533u^2t^4 - 14102u^3t^3 - 10237u^4t^2 \\
& - 2876u^5t - 167u^6)s^2 + 30t^6u^5(t + u)^6(10t^3 + 37ut^2 + 37u^2t + 14u^3)s + 120t^7u^6(t + u)^6(t^2 + ut + u^2) H(1, 0, z)(s + u)^2 \\
& + 18s^2t^2(s + t)^2u^2((11t^6 + 162ut^5 + 129u^2t^4 + 796u^3t^3 + 129u^4t^2 + 162u^5t + 11u^6)s^12 + 6(11t^7 + 193ut^6 + 349u^2t^5 + 1047u^3t^4 \\
& + 1027u^4t^3 + 313u^5t^2 + 173u^6t + 7u^7)s^11 + (187t^8 + 3280ut^7 + 8506u^2t^6 + 20204u^3t^5 + 32372u^4t^4 + 18608u^5t^3 + 6910u^6t^2 \\
& + 2596u^7t + 73u^8)s^10 + 2(165t^9 + 2522ut^8 + 8324u^2t^7 + 17309u^3t^6 + 35002u^4t^5 + 33469u^5t^4 + 14236u^6t^3 + 6119u^7t^2 + 1745u^8t \\
& + 53u^9)s^9 + (396t^{10} + 4920ut^9 + 19227u^2t^8 + 34792u^3t^7 + 71793u^4t^6 + 105726u^5t^5 + 63533u^6t^4 + 25164u^7t^3 + 13635u^8t^2 \\
& + 3190u^9t + 168u^{10})s^8 + 2(165t^{11} + 1725ut^{10} + 7356u^2t^9 + 10992u^3t^8 + 12447u^4t^7 + 31129u^5t^6 + 30585u^6t^5 + 10947u^7t^4 \\
& + 9212u^8t^3 + 6186u^9t^2 + 1323u^{10}t + 109u^{11})s^7 + (187t^{12} + 1872ut^{11} + 8220u^2t^{10} + 10632u^3t^9 - 15915u^4t^8 - 29212u^5t^7 - 9538u^6t^6 \\
& - 13152u^7t^5 + 1543u^8t^4 + 19604u^9t^3 + 10518u^{10}t^2 + 2096u^{11}t + 185u^{12})s^6 + 2(33t^{13} + 372ut^{12} + 1782u^2t^{11} + 2908u^3t^{10} \\
& - 8202u^4t^9 - 31332u^5t^8 - 35999u^6t^7 - 26337u^7t^6 - 11010u^8t^5 + 8183u^9t^4 + 10293u^{10}t^3 + 3681u^{11}t^2 + 623u^{12}t + 45u^{13})s^5 \\
& + (11t^{14} + 182u^2t^{13} + 1142u^2t^{12} + 3266u^3t^{11} - 2041u^4t^{10} - 30594u^5t^9 - 56568u^6t^8 - 48084u^7t^7 - 20480u^8t^6 + 13148u^9t^5
\end{aligned}$$

$$\begin{aligned}
& +25835u^{10}t^4 + 13918u^{11}t^3 + 3530u^{12}t^2 + 452u^{13}t + 19u^{14})s^4 + 2tu(10t^{13} + 115ut^{12} + 604u^2t^{11} + 1366u^3t^{10} - 633u^4t^9 - 5650u^5t^8 \\
& - 5310u^6t^7 + 1442u^7t^6 + 9166u^8t^5 + 12427u^9t^4 + 8168u^{10}t^3 + 2766u^{11}t^2 + 499u^{12}t + 38u^{13})s^3 + t^2u^2(t+u)^2(24t^{10} + 190ut^9 \\
& + 841u^2t^8 + 1482u^3t^7 + 1601u^4t^6 + 4172u^5t^5 + 4881u^6t^4 + 5362u^7t^3 + 3151u^8t^2 + 930u^9t + 126u^{10})s^2 + 2t^3u^3(t+u)^3(10t^8 \\
& + 70ut^7 + 248u^2t^6 + 399u^3t^5 + 669u^4t^4 + 647u^5t^3 + 545u^6t^2 + 236u^7t + 48u^8)s + t^4u^4(t+u)^6(11t^4 + 22ut^3 + 39u^2t^2 + 28u^3t \\
& + 33u^4)H(0, y)H(1, 0, z)(s+u)^2 + 18s^2t^2(s+t)^2u^2(4(2t^6 + 36ut^5 + 21u^2t^4 + 184u^3t^3 + 21u^4t^2 + 36u^5t + 2u^6)s^{12} + 12(4t^7 \\
& + 88u^6 + 155u^2t^5 + 501u^3t^4 + 501u^4t^3 + 155u^5t^2 + 88u^6t + 4u^7)s^{11} + 2(65t^8 + 1472ut^7 + 3872u^2t^6 + 9748u^3t^5 + 16246u^4t^4 \\
& + 9748u^5t^3 + 3872u^6t^2 + 1472u^7t + 65u^8)s^{10} + 2(105t^9 + 2168ut^8 + 7571u^2t^7 + 16917u^3t^6 + 36199u^4t^5 + 36199u^5t^4 + 16917u^6t^3 \\
& + 7571u^7t^2 + 2168u^8t + 105u^9)s^9 + 3(77t^{10} + 1342ut^9 + 5977u^2t^8 + 12336u^3t^7 + 27698u^4t^6 + 41828u^5t^5 + 27698u^6t^4 + 12336u^7t^3 \\
& + 5977u^8t^2 + 1342u^9t + 77u^{10})s^8 + 6(32t^{11} + 470ut^{10} + 2531u^2t^9 + 5259u^3t^8 + 9133u^4t^7 + 18639u^5t^6 + 18639u^6t^5 + 9133u^7t^4 \\
& + 5259u^8t^3 + 2531u^9t^2 + 470u^{10}t + 32u^{11})s^7 + 4(31t^{12} + 423ut^{11} + 2589u^2t^{10} + 6536u^3t^9 + 7785u^4t^8 + 13437u^5t^7 + 20822u^6t^6 \\
& + 13437u^7t^5 + 7785u^8t^4 + 6536u^9t^3 + 2589u^{10}t^2 + 423u^{11}t + 31u^{12})s^6 + 6(9t^{13} + 136ut^{12} + 957u^2t^{11} + 3300u^3t^{10} + 4871u^4t^9 \\
& + 4588u^5t^8 + 7179u^6t^7 + 7179u^7t^6 + 4588u^8t^5 + 4871u^9t^4 + 3300u^{10}t^3 + 957u^{11}t^2 + 136u^{12}t + 9u^{13})s^5 + (11t^{14} + 266ut^{13} \\
& + 2351u^2t^{12} + 10990u^3t^{11} + 25897u^4t^{10} + 32638u^5t^9 + 37273u^6t^8 + 44116u^7t^7 + 37273u^8t^6 + 32638u^9t^5 + 25897u^{10}t^4 + 10990u^{11}t^3 \\
& + 2351u^{12}t^2 + 266u^{13}t + 11u^{14})s^4 + 2tu(22t^{13} + 307ut^{12} + 1948u^2t^{11} + 6827u^3t^{10} + 13580u^4t^9 + 19041u^5t^8 + 23579u^6t^7 + 23579u^7t^6 \\
& + 19041u^8t^5 + 13580u^9t^4 + 6827u^{10}t^3 + 1948u^{11}t^2 + 307u^{12}t + 22u^{13})s^3 + 6t^2u^2(t+u)^2(13t^{10} + 105ut^9 + 430u^2t^8 + 940u^3t^7 \\
& + 1317u^4t^6 + 1682u^5t^5 + 1317u^6t^4 + 940u^7t^3 + 430u^8t^2 + 105u^9t + 13u^{10})s^2 + 4t^3u^3(t+u)^3(16t^8 + 91ut^7 + 262u^2t^6 + 410u^3t^5 \\
& + 530u^4t^4 + 410u^5t^3 + 262u^6t^2 + 91u^7t + 16u^8)s + t^4u^4(t+u)^6(25t^4 + 34ut^3 + 54u^2t^2 + 34u^3t + 25u^4)H(0, z)H(2, 0, y)(s+u)^2 \\
& + 18s^2t^2u^2(6(11t^6 + 46ut^5 + 156u^2t^4 + 102u^3t^3 + 156u^4t^2 + 46u^5t + 11u^6)s^{14} + 2(270t^7 + 1259ut^6 + 4389u^2t^5 + 4796u^3t^4 \\
& + 5120u^4t^3 + 3729u^5t^2 + 1049u^6t + 204u^7)s^{13} + (2055t^8 + 10770ut^7 + 38032u^2t^6 + 57306u^3t^5 + 58498u^4t^4 + 54214u^5t^3 + 27450u^6t^2 \\
& + 7450u^7t + 1185u^8)s^{12} + 2(2410t^9 + 14457ut^8 + 51810u^2t^7 + 97505u^3t^6 + 109719u^4t^5 + 108252u^5t^4 + 77806u^6t^3 + 32031u^7t^2 \\
& + 8199u^8t + 1059u^9)s^{11} + (7744t^{10} + 53588ut^9 + 198480u^2t^8 + 439066u^3t^7 + 579501u^4t^6 + 598332u^5t^5 + 517783u^6t^4 + 294682u^7t^3 \\
& + 105495u^8t^2 + 24196u^9t + 2541u^{10})s^{10} + 2(4458t^{11} + 35621ut^{10} + 138966u^2t^9 + 344982u^3t^8 + 538700u^4t^7 + 609874u^5t^6 \\
& + 590760u^6t^5 + 426236u^7t^4 + 200386u^8t^3 + 62613u^9t^2 + 12146u^{10}t + 1050u^{11})s^9 + (7450t^{12} + 68928ut^{11} + 290076u^2t^{10} \\
& + 782276u^3t^9 + 1406634u^4t^8 + 1787400u^5t^7 + 1901521u^6t^6 + 1654302u^7t^5 + 999621u^8t^4 + 402156u^9t^3 + 106839u^{10}t^2 + 16578u^{11}t \\
& + 1179u^{12})s^8 + 2(2230t^{13} + 24137ut^{12} + 113268u^2t^{11} + 330723u^3t^{10} + 666867u^4t^9 + 948111u^5t^8 + 1082558u^6t^7 + 1072690u^7t^6 \\
& + 809304u^8t^5 + 421377u^9t^4 + 148590u^{10}t^3 + 32739u^{11}t^2 + 3807u^{12}t + 207u^{13})s^7 + (1830t^{14} + 23864ut^{13} + 129744u^2t^{12} \\
& + 419622u^3t^{11} + 946629u^4t^{10} + 1526944u^5t^9 + 1879479u^6t^8 + 1986148u^7t^7 + 1729402u^8t^6 + 1108500u^9t^5 + 506934u^{10}t^4 \\
& + 157722u^{11}t^3 + 28413u^{12}t^2 + 2220u^{13}t + 69u^{14})s^6 + 2t(232t^{14} + 3972ut^{13} + 26409u^2t^{12} + 97770u^3t^{11} + 247866u^4t^{10} \\
& + 463269u^5t^9 + 652628u^6t^8 + 749862u^7t^7 + 712998u^8t^6 + 514895u^9t^5 + 272466u^{10}t^4 + 106176u^{11}t^3 + 28022u^{12}t^2 + 3996u^{13}t \\
& + 159u^{14})s^5 + t^2(55t^{14} + 1614ut^{13} + 14748u^2t^{12} + 66434u^3t^{11} + 190555u^4t^{10} + 406308u^5t^9 + 671989u^6t^8 + 896290u^7t^7 \\
& + 978039u^8t^6 + 811640u^9t^5 + 480198u^{10}t^4 + 201792u^{11}t^3 + 59561u^{12}t^2 + 11310u^{13}t + 1083u^{14})s^4 + 2t^3u(74t^{13} + 1262ut^{12} \\
& + 7944u^2t^{11} + 27682u^3t^{10} + 67049u^4t^9 + 125496u^5t^8 + 189647u^6t^7 + 237429u^7t^6 + 234672u^8t^5 + 169330u^9t^4 + 85057u^{10}t^3 \\
& + 28209u^{11}t^2 + 5389u^{12}t + 424u^{13})s^3 + t^4u^2(t+u)^2(192t^{10} + 1868ut^9 + 7244u^2t^8 + 17304u^3t^7 + 30738u^4t^6 + 40806u^5t^5 \\
& + 45573u^6t^4 + 36880u^7t^3 + 20764u^8t^2 + 7278u^9t + 1137u^{10})s^2 + 2t^5u^3(t+u)^3(64t^8 + 420u^7t^7 + 1164u^2t^6 + 2189u^3t^5 + 2787u^4t^4 \\
& + 2772u^5t^3 + 1870u^6t^2 + 855u^7t + 183u^8)s + t^6u^4(t+u)^6(47t^4 + 64ut^3 + 117u^2t^2 + 92u^3t + 83u^4)H(0, 1, 0, z)(s+u)^2
\end{aligned}$$

$$\begin{aligned}
& + 36s^2t^2(s+t)^6u^2(t+u)^6 \left( 22s^8 + 44(t+3u)s^7 + 2(33t^2 + 70ut + 187u^2) s^6 + (44t^3 + 246ut^2 + 147u^2t + 660u^3) s^5 + (22t^4 \right. \\
& + 115u t^3 + 360u^2t^2 + 41u^3t + 792u^4) s^4 + u(64t^4 + 95ut^3 + 246u^2t^2 + 2u^3t + 660u^4) s^3 + u^2(84t^4 + 9ut^3 + 84u^2t^2 + 54u^3t \\
& + 374u^4) s^2 + u^3(54t^4 - 11ut^3 + 36u^2t^2 + 63u^3t + 132u^4) s + u^4(18t^4 + 4ut^3 + 18u^2t^2 + 21u^3t + 22u^4) \left. \right) H(1, 0, 0, z)(s+u)^2 \\
& + 36s^2t^2u^3 \left( (48t^5 - 6u t^4 + 332u^2t^3 + 45u^3t^2 + 90u^4t + 11u^5) s^{14} + (420t^6 + 282u t^5 + 2684u^2t^4 + 2292u^3t^3 + 810u^4t^2 \right. \\
& + 542u^5t + 42u^6) s^{13} + (1386t^7 + 1149ut^6 + 7038u^2t^5 + 12044u^3t^4 + 4972u^4t^3 + 2592u^5t^2 + 1202u^6t + 73u^7) s^{12} \\
& + (2181t^8 - 6ut^7 + 3u^2t^6 + 15414u^3t^5 + 7299u^4t^4 - 896u^5t^3 + 2931u^6t^2 + 1368u^7t + 106u^8) s^{11} + (985t^9 - 9867ut^8 \\
& - 44480u^2t^7 - 48559u^3t^6 - 45186u^4t^5 - 50331u^5t^4 - 19580u^6t^3 + 585u^7t^2 + 1097u^8t + 168u^9) s^{10} - (2469t^{10} + 31352ut^9 \\
& + 135204u^2t^8 + 241022u^3t^7 + 253354u^4t^6 + 222072u^5t^5 + 127806u^6t^4 + 30846u^7t^3 + 657u^8t^2 - 980u^9t - 218u^{10}) s^9 \\
& - (5517t^{11} + 52233ut^{10} + 228083u^2t^9 + 506619u^3t^8 + 645063u^4t^7 + 575952u^5t^6 + 368997u^6t^5 + 131304u^7t^4 + 16832u^8t^3 \\
& - 1527u^9t^2 - 936u^{10}t - 185u^{11}) s^8 - (5797t^{12} + 55314ut^{11} + 250929u^2t^{10} + 646444u^3t^9 + 990366u^4t^8 + 1001980u^5t^7 \\
& + 717884u^6t^6 + 319380u^7t^5 + 58843u^8t^4 - 6082u^9t^3 - 4017u^{10}t^2 - 684u^{11}t - 90u^{12}) s^7 - (3849t^{13} + 40039ut^{12} + 191778u^2t^{11} \\
& + 546879u^3t^{10} + 969791u^4t^9 + 1126182u^5t^8 + 922078u^6t^7 + 512534u^7t^6 + 148569u^8t^5 - 1403u^9t^4 - 14004u^{10}t^3 - 3726u^{11}t^2 \\
& - 315u^{12}t - 19u^{13}) s^6 - t(1647t^{13} + 19818ut^{12} + 104248u^2t^{11} + 323862u^3t^{10} + 638973u^4t^9 + 819288u^5t^8 + 723606u^6t^7 + 455700u^7t^6 \\
& + 180305u^8t^5 + 24144u^9t^4 - 13260u^{10}t^3 - 8070u^{11}t^2 - 1683u^{12}t - 66u^{13}) s^5 - t^2(413t^{13} + 6240ut^{12} + 38435u^2t^{11} + 133574u^3t^{10} \\
& + 291906u^4t^9 + 405133u^5t^8 + 357472u^6t^7 + 200055u^7t^6 + 58195u^8t^5 - 7313u^9t^4 - 13779u^{10}t^3 - 6238u^{11}t^2 - 1920u^{12}t - 309u^{13}) s^4 \\
& - t^3(48t^{13} + 1112ut^{12} + 8730u^2t^{11} + 35276u^3t^{10} + 86245u^4t^9 + 130602u^5t^8 + 113599u^6t^7 + 38248u^7t^6 - 30777u^8t^5 - 50450u^9t^4 \\
& - 31999u^{10}t^3 - 10602u^{11}t^2 - 1774u^{12}t - 114u^{13}) s^3 - t^4u(t+u)^2(84t^{10} + 898ut^9 + 3400u^2t^8 + 6309u^3t^7 + 5217u^4t^6 - 2505u^5t^5 \\
& - 8514u^6t^4 - 9343u^7t^3 - 5743u^8t^2 - 2007u^9t - 336u^{10}) s^2 - t^5u^2(t+u)^3(48t^8 + 200ut^7 + 135u^2t^6 - 571u^3t^5 - 1726u^4t^4 - 1854u^5t^3 \\
& - 1219u^6t^2 - 459u^7t - 90u^8) s + t^6u^4(t+u)^6(23t^3 + 54ut^2 + 46u^2t + 26u^3) \left. \right) H(1, 1, 0, z)(s+u)^2 + 9(s+t)^2u^2(t+u) \left( 2(92t^7 + 224ut^6 \right. \\
& + 807u^2t^5 + 41u^3t^4 + 227u^4t^3 + 71u^5t^2 + 70u^6t + 20u^7) s^{15} + 2(548t^8 + 1800ut^7 + 6507u^2t^6 + 5556u^3t^5 + 2001u^4t^4 + 2149u^5t^3 \\
& + 864u^6t^2 + 535u^7t + 120u^8) s^{14} + (3080t^9 + 12672ut^8 + 43909u^2t^7 + 68677u^3t^6 + 39172u^4t^5 + 27176u^5t^4 + 19411u^6t^3 + 8427u^7t^2 \\
& + 3620u^8t + 640u^9) s^{13} + (5400t^{10} + 26796ut^9 + 85362u^2t^8 + 182471u^3t^7 + 168303u^4t^6 + 105098u^5t^5 + 92562u^6t^4 + 53097u^7t^3 \\
& + 21885u^8t^2 + 7050u^9t + 1000u^{10}) s^{12} + (6464t^{11} + 38196ut^{10} + 114563u^2t^9 + 283713u^3t^8 + 385450u^4t^7 + 275704u^5t^6 + 227431u^6t^5 \\
& + 183473u^7t^4 + 90148u^8t^3 + 33770u^9t^2 + 8600u^{10}t + 1000u^{11}) s^{11} + (5400t^{12} + 38196ut^{11} + 123420u^2t^{10} + 320669u^3t^9 + 573417u^4t^8 \\
& + 513000u^5t^7 + 343086u^6t^6 + 321375u^7t^5 + 218509u^8t^4 + 96742u^9t^3 + 32200u^{10}t^2 + 6690u^{11}t + 640u^{12}) s^{10} + (3080t^{13} + 26796ut^{12} \\
& + 114563u^2t^{11} + 320669u^3t^{10} + 641380u^4t^9 + 698714u^5t^8 + 386310u^6t^7 + 282028u^7t^6 + 279284u^8t^5 + 162550u^9t^4 + 65139u^{10}t^3 \\
& + 18779u^{11}t^2 + 3220u^{12}t + 240u^{13}) s^9 + (1096t^{14} + 12672ut^{13} + 85362u^2t^{12} + 283713u^3t^{11} + 573417u^4t^{10} + 698714u^5t^9 \\
& + 392272u^6t^8 + 129314u^7t^7 + 178058u^8t^6 + 158492u^9t^5 + 72298u^{10}t^4 + 25025u^{11}t^3 + 6257u^{12}t^2 + 870u^{13}t + 40u^{14}) s^8 + t(184t^{14} \\
& + 3600ut^{13} + 43909u^2t^{12} + 182471u^3t^{11} + 385450u^4t^{10} + 513000u^5t^9 + 386310u^6t^8 + 129314u^7t^7 + 92160u^8t^6 + 110380u^9t^5 \\
& + 48211u^{10}t^4 + 11865u^{11}t^3 + 3700u^{12}t^2 + 994u^{13}t + 100u^{14}) s^7 + t^2u(448t^{13} + 13014ut^{12} + 68677u^2t^{11} + 168303u^3t^{10} \\
& + 275704u^4t^9 + 343086u^5t^8 + 282028u^6t^7 + 178058u^7t^6 + 110380u^8t^5 + 33784u^9t^4 - 4267u^{10}t^3 - 3791u^{11}t^2 - 474u^{12}t + 42u^{13}) s^6 \\
& + t^3u^2(1614t^{12} + 11112ut^{11} + 39172u^2t^{10} + 105098u^3t^9 + 227431u^4t^8 + 321375u^5t^7 + 279284u^6t^6 + 158492u^7t^5 + 48211u^8t^4 \\
& - 4267u^9t^3 - 7188u^{10}t^2 - 1770u^{11}t - 164u^{12}) s^5 + t^4u^3(82t^{11} + 4002ut^{10} + 27176u^2t^9 + 92562u^3t^8 + 183473u^4t^7 + 218509u^5t^6 \\
& + 162550u^6t^5 + 72298u^7t^4 + 11865u^8t^3 - 3791u^9t^2 - 1770u^{10}t - 204u^{11}) s^4 + t^5u^4(t+u)^2(454t^8 + 3390ut^7 + 12177u^2t^6 \\
& + 25353u^3t^5 + 27265u^4t^4 + 16859u^5t^3 + 4156u^6t^2 - 146u^7t - 164u^8) s^3 + t^6u^5(t+u)^3(142t^6 + 1302ut^5 + 4095u^2t^4 + 5552u^3t^3 \\
& + 3527u^4t^2 + 868u^5t + 42u^6) s^2 + 10t^7u^6(t+u)^5(14t^3 + 37ut^2 + 37u^2t + 10u^3) s + 40t^8u^7(t+u)^5(t^2 + ut + u^2) \left. \right) H(1, 0, y)(s+u) \\
& - 3s^2(s+t)^2u^2(t+u)^2 \left( (259t^6 + 616ut^5 + 426u^2t^4 - 68u^3t^3 + 109u^4t^2 + 300u^5t + 120u^6) s^{14} + 2(774t^7 + 2870u t^6 + 3872u^2t^5 \right. \\
& + 1903u^3t^4 + 425u^4t^3 + 1339u^5t^2 + 1395u^6t + 420u^7) s^{13} + (4367t^8 + 21396ut^7 + 40759u^2t^6 + 37858u^3t^5 + 19215u^4t^4 + 14984u^5t^3 \\
& + 18489u^6t^2 + 11430u^7t + 2640u^8) s^{12} + 2(3840t^9 + 23121ut^8 + 56244u^2t^7 + 72977u^3t^6 + 57956u^4t^5 + 40878u^5t^4 + 39401u^6t^3 \\
& + 31286u^7t^2 + 13545u^8t + 2460u^9) s^{11} + 2(4602t^{10} + 33792ut^9 + 102876u^2t^8 + 170653u^3t^7 + 175620u^4t^6 + 137297u^5t^5 + 118565u^6t^4 \\
& + 104385u^7t^3 + 62005u^8t^2 + 20475u^9t + 3000u^{10}) s^{10} + 2(3840t^{11} + 35847ut^{10} + 140082u^2t^9 + 290657u^3t^8 + 356593u^4t^7 \\
& + 294815u^5t^6 + 230739u^6t^5 + 215383u^7t^4 + 164395u^8t^3 + 77358u^9t^2 + 20475u^{10}t + 2460u^{11}) s^9 + (4367t^{12} + 55904ut^{11} \\
& + 291138u^2t^{10} + 756156u^3t^9 + 1095009u^4t^8 + 963078u^5t^7 + 649134u^6t^6 + 554262u^7t^5 + 519114u^8t^4 + 328790u^9t^3 + 124010u^{10}t^2 \\
& + 27090u^{11}t + 2640u^{12}) s^8 + 2(774t^{13} + 15265ut^{12} + 110242u^2t^{11} + 363648u^3t^{10} + 642258u^4t^9 + 661734u^5t^8 + 447563u^6t^7 \\
& + 300068u^7t^6 + 277131u^8t^5 + 215383u^9t^4 + 104385u^{10}t^3 + 31286u^{11}t^2 + 5715u^{12}t + 420u^{13}) s^7 + (259t^{14} + 10260ut^{13} + 111068u^2t^{12}
\end{aligned}$$

$$\begin{aligned}
& +486996u^3 t^{11} + 1107162u^4 t^{10} + 1479900u^5 t^9 + 1291792u^6 t^8 + 895126u^7 t^7 + 649134u^8 t^6 + 461478u^9 t^5 + 237130u^{10} t^4 + 78802u^{11} t^3 \\
& + 18489 u^{12} t^2 + 2790u^{13} t + 120u^{14}) s^6 + 2tu(777t^{13} + 16074 ut^{12} + 104819u^2 t^{11} + 330308u^3 t^{10} + 608514u^4 t^9 + 739950u^5 t^8 \\
& + 661734u^6 t^7 + 481539u^7 t^6 + 294815u^8 t^5 + 137297u^9 t^4 + 40878u^{10} t^3 + 7492u^{11} t^2 + 1339u^{12} t + 150u^{13}) s^5 + t^2 u^2 (3885 t^{12} \\
& + 50940ut^{11} + 249466u^2 t^{10} + 660616u^3 t^9 + 1107162u^4 t^8 + 1284516u^5 t^7 + 1095009u^6 t^6 + 713186u^7 t^5 + 351240u^8 t^4 + 115912u^9 t^3 \\
& + 19215u^{10} t^2 + 850u^{11} t + 109u^{12}) s^4 + 2t^3 u^3 (2590 t^{11} + 25470ut^{10} + 104819u^2 t^9 + 243498u^3 t^8 + 363648u^4 t^7 + 378078 u^5 t^6 \\
& + 290657u^6 t^5 + 170653u^7 t^4 + 72977u^8 t^3 + 18929u^9 t^2 + 1903 u^{10} t - 34u^{11}) s^3 + t^4 u^4 (t + u)^2 (3885t^8 + 24378u t^7 + 58427u^2 t^6 \\
& + 79252u^3 t^5 + 74207u^4 t^4 + 52498u^5 t^3 + 26549u^6 t^2 + 6892u^7 t + 426u^8) s^2 + 2t^5 u^5 (t + u)^3 (777t^6 + 2799u t^5 + 4537u^2 t^4 + 5167u^3 t^3 \\
& + 3936u^4 t^2 + 1946u^5 t + 308u^6) s + t^6 u^6 (t + u)^4 (259t^4 + 512ut^3 + 765u^2 t^2 + 512u^3 t + 259 u^4) H(0, y)H(1, z) + 9s^2 (t + u)^2 (2(20t^8 \\
& + 50u t^7 + 21u^2 t^6 - 82u^3 t^5 - 102u^4 t^4 - 82u^5 t^3 + 21u^6 t^2 + 50u^7 t + 20 u^8) s^{16} + 2(140t^9 + 505ut^8 + 568u^2 t^7 - 298u^3 t^6 - 1069u^4 t^5 \\
& - 1069u^5 t^4 - 298u^6 t^3 + 568u^7 t^2 + 505u^8 t + 140u^9) s^{15} + (880t^{10} + 4370ut^9 + 8221u^2 t^8 + 4262u^3 t^7 - 6199u^4 t^6 - 10932u^5 t^5 \\
& - 6199u^6 t^4 + 4262u^7 t^3 + 8221u^8 t^2 + 4370u^9 t + 880 u^{10}) s^{14} + 2(820t^{11} + 5395ut^{10} + 14563u^2 t^9 + 17988 u^3 t^8 + 5650u^4 t^7 - 8508u^5 t^6 \\
& - 8508u^6 t^5 + 5650u^7 t^4 + 17988u^8 t^3 + 14563u^9 t^2 + 5395u^{10} t + 820u^{11}) s^{13} + (2000 t^{12} + 16930ut^{11} + 60889u^2 t^{10} + 115200u^3 t^9 \\
& + 112888u^4 t^8 + 52018 u^5 t^7 + 18062u^6 t^6 + 52018u^7 t^5 + 112888u^8 t^4 + 115200u^9 t^3 + 60889 u^{10} t^2 + 16930u^{11} t + 2000u^{12}) s^{12} + 2(820t^{13} \\
& + 8825 ut^{12} + 40630u^2 t^{11} + 106430u^3 t^{10} + 162506u^4 t^9 + 145433u^5 t^8 + 94054u^6 t^7 + 94054u^7 t^6 + 145433u^8 t^5 + 162506u^9 t^4 \\
& + 106430u^{10} t^3 + 40630u^{11} t^2 + 8825u^{12} t + 820u^{13}) s^{11} + (880 t^{14} + 12310ut^{13} + 71305u^2 t^{12} + 252860u^3 t^{11} + 542940u^4 t^{10} \\
& + 672624u^5 t^9 + 495141u^6 t^8 + 346704u^7 t^7 + 495141u^8 t^6 + 672624 u^9 t^5 + 542940u^{10} t^4 + 252860u^{11} t^3 + 71305u^{12} t^2 + 12310u^{13} t \\
& + 880u^{14}) s^{10} + 2(140t^{15} + 2785ut^{14} + 20491u^2 t^{13} + 99450u^3 t^{12} + 294436u^4 t^{11} + 490859u^5 t^{10} + 448931u^6 t^9 + 254956u^7 t^8 \\
& + 254956u^8 t^7 + 448931u^9 t^6 + 490859u^{10} t^5 + 294436 u^{11} t^4 + 99450u^{12} t^3 + 20491u^{13} t^2 + 2785u^{14} t + 140u^{15}) s^9 + (40t^{16} + 1490ut^{15} \\
& + 14845u^2 t^{14} + 102820u^3 t^{13} + 419280 u^4 t^{12} + 950788u^5 t^{11} + 1225773u^6 t^{10} + 975710u^7 t^9 + 743060u^8 t^8 + 975710u^9 t^7 + 1225773u^{10} t^6 \\
& + 950788u^{11} t^5 + 419280u^{12} t^4 + 102820u^{13} t^3 + 14845u^{14} t^2 + 1490u^{15} t + 40u^{16}) s^8 + 2tu(90t^{15} + 1540ut^{14} + 16932u^2 t^{13} + 96123u^3 t^{12} \\
& + 304282 u^4 t^{11} + 583798u^5 t^{10} + 762212u^6 t^9 + 803305u^7 t^8 + 803305u^8 t^7 + 762212u^9 t^6 + 583798u^{10} t^5 + 304282u^{11} t^4 + 96123u^{12} t^3 \\
& + 16932u^{13} t^2 + 1540u^{14} t + 90u^{15}) s^7 + t^2 u^2 (282 t^{14} + 6622ut^{13} + 54887u^2 t^{12} + 264008u^3 t^{11} + 776536u^4 t^{10} + 1517240u^5 t^9 \\
& + 2171441u^6 t^8 + 2431080u^7 t^7 + 2171441u^8 t^6 + 1517240u^9 t^5 + 776536u^{10} t^4 + 264008u^{11} t^3 + 54887u^{12} t^2 + 6622u^{13} t + 282u^{14}) s^6 \\
& + 2t^3 u^3 (298t^{13} + 4418u t^{12} + 40731u^2 t^{11} + 190625u^3 t^{10} + 505964u^4 t^9 + 877790u^5 t^8 + 1117090u^6 t^7 + 1117090u^7 t^6 + 877790u^8 t^5 \\
& + 505964u^9 t^4 + 190625 u^{10} t^3 + 40731u^{11} t^2 + 4418u^{12} t + 298u^{13}) s^5 + t^4 u^4 (536t^{12} + 16810ut^{11} + 131975u^2 t^{10} + 463360u^3 t^9 \\
& + 936996u^4 t^8 + 1292362u^5 t^7 + 1406138u^6 t^6 + 1292362u^7 t^5 + 936996u^8 t^4 + 463360 u^9 t^3 + 131975u^{10} t^2 + 16810u^{11} t + 536u^{12}) s^4 \\
& + 2t^5 u^5 (848t^{11} + 13094ut^{10} + 64600u^2 t^9 + 162207u^3 t^8 + 255217u^4 t^7 + 298424u^5 t^6 + 298424u^6 t^5 + 255217u^7 t^4 + 162207u^8 t^3 \\
& + 64600u^9 t^2 + 13094u^{10} t + 848u^{11}) s^3 + t^6 u^6 (t + u)^2 (2062 t^8 + 13122ut^7 + 32971u^2 t^6 + 48846u^3 t^5 + 54292u^4 t^4 + 48846u^5 t^3 \\
& + 32971u^6 t^2 + 13122u^7 t + 2062u^8) s^2 + 4t^7 u^7 (t + u)^3 (158t^6 + 746ut^5 + 1500u^2 t^4 + 1923u^3 t^3 + 1500u^4 t^2 + 746u^5 t + 158 u^6) s \\
& + 8t^8 u^8 (t + u)^4 (23t^4 + 45ut^3 + 67u^2 t^2 + 45u^3 t + 23 u^4) H(1, z)H(3, y) + 3s^2 (s + t)u^2 (t + u)^2 ((17 t^6 - 424ut^5 - 1038u^2 t^4 - 1108u^3 t^3 \\
& - 133u^4 t^2 + 300u^5 t + 120u^6) s^{15} + (113t^7 - 2432ut^6 - 9046u^2 t^5 - 13902u^3 t^4 - 8627u^4 t^3 + 1042 u^5 t^2 + 2910u^6 t + 840u^7) s^{14} + (361t^8 \\
& - 5422ut^7 - 30575u^2 t^6 - 64296u^3 t^5 - 66643u^4 t^4 - 21748u^5 t^3 + 14031u^6 t^2 + 12270u^7 t + 2640 u^8) s^{13} + (745t^9 - 5220ut^8 - 49927u^2 t^7 \\
& - 141944u^3 t^6 - 209881u^4 t^5 - 146102u^5 t^4 - 877u^6 t^3 + 57146u^7 t^2 + 29730u^8 t + 4920 u^9) s^{12} + 2(546t^{10} + 2738ut^9 - 12316u^2 t^8 \\
& - 77546u^3 t^7 - 169106u^4 t^6 - 184458u^5 t^5 - 65973u^6 t^4 + 53495u^7 t^3 + 62003u^8 t^2 + 22935u^9 t + 3000u^{10}) s^{11} + 2(576t^{11} + 14602u t^{10} \\
& + 44395u^2 t^9 + 6575u^3 t^8 - 159019u^4 t^7 - 299169u^5 t^6 - 202668u^6 t^5 + 31945u^7 t^4 + 130735u^8 t^3 + 82071u^9 t^2 + 23475u^{10} t + 2460 u^{11}) s^{10} \\
& + (853t^{12} + 50204ut^{11} + 239326u^2 t^{10} + 380158u^3 t^9 - 5759u^4 t^8 - 778482u^5 t^7 - 981862u^6 t^6 - 306108u^7 t^5 + 310132u^8 t^4 \\
& + 327562u^9 t^3 + 138034u^{10} t^2 + 32010u^{11} t + 2640 u^{12}) s^9 + (421t^{13} + 48756ut^{12} + 284228u^2 t^{11} + 643716 u^3 t^{10} + 559919u^4 t^9 \\
& - 346654u^5 t^8 - 1327656u^6 t^7 - 1188026u^7 t^6 - 185900u^8 t^5 + 356130u^9 t^4 + 244634u^{10} t^3 + 72974u^{11} t^2 + 14070 u^{12} t + 840u^{13}) s^8 \\
& + (125t^{14} + 28668ut^{13} + 194932u^2 t^{12} + 556848u^3 t^{11} + 840628u^4 t^{10} + 624124u^5 t^9 - 174342u^6 t^8 - 974758u^7 t^7 - 907984u^8 t^6 \\
& - 201510u^9 t^5 + 170032u^{10} t^4 + 108262 u^{11} t^3 + 22743u^{12} t^2 + 3630u^{13} t + 120u^{14}) s^7 + t(17 t^{14} + 9532ut^{13} + 79874u^2 t^{12} + 311220u^3 t^{11} \\
& + 718808u^4 t^{10} + 1133540u^5 t^9 + 1280316u^6 t^8 + 835978u^7 t^7 - 19040u^8 t^6 - 455158 u^9 t^5 - 255266u^{10} t^4 - 6292u^{11} t^3 + 26245u^{12} t^2 \\
& + 3544u^{13} t + 420 u^{14}) s^6 + t^2 u (1338t^{13} + 17115ut^{12} + 122578u^2 t^{11} + 473242u^3 t^{10} + 1064256u^4 t^9 + 1563708u^5 t^8 + 1630684u^6 t^7 \\
& + 1174609u^7 t^6 + 432306u^8 t^5 - 92986u^9 t^4 - 158896u^{10} t^3 - 40833 u^{11} t^2 + 2954u^{12} t + 167u^{13}) s^5 + t^3 u^2 (1209 t^{12} + 30536ut^{11} \\
& + 210974u^2 t^{10} + 653148u^3 t^9 + 1105716u^4 t^8 + 1162604u^5 t^7 + 908135u^6 t^6 + 653214u^7 t^5 + 380872u^8 t^4 + 92158u^9 t^3 - 31479u^{10} t^2 \\
& - 16364u^{11} t + 67u^{12}) s^4 + t^4 u^3 (3688 t^{11} + 49261ut^{10} + 216624u^2 t^9 + 465668u^3 t^8 + 558504u^4 t^7 + 411820 u^5 t^6 + 264280u^6 t^5
\end{aligned}$$

$$\begin{aligned}
& + 237894u^7t^4 + 185882u^8t^3 + 72173u^9t^2 + 5494u^{10}t - 2344u^{11})s^3 + t^5u^4(t+u)^2(4269t^8 + 21666ut^7 + 42801u^2t^6 + 45136u^3t^5 \\
& + 32315u^4t^4 + 22162u^5t^3 + 17975u^6t^2 + 9856u^7t + 2252u^8)s^2 + t^6u^5(t+u)^3(762t^6 + 3225u^5t^5 + 6713u^2t^4 + 8777u^3t^3 + 5973u^4t^2 \\
& + 1975u^5t + 49u^6)s + t^7u^6(t+u)^4(293t^4 + 568ut^3 + 843u^2t^2 + 568u^3t + 293u^4)H(0, 1, z) + 18s^2t^2(s+t)^2u^2(t+u)^2((11t^4 + 20ut^3 \\
& + 24u^2t^2 + 20u^3t + 11u^4)s^{14} + 2(33t^5 + 91ut^4 + 115u^2t^3 + 119u^3t^2 + 100u^4t + 44u^5)s^{13} + (187t^6 + 744ut^5 + 1142u^2t^4 + 1208u^3t^3 \\
& + 1245u^4t^2 + 976u^5t + 336u^6)s^{12} + 2(165t^7 + 936ut^6 + 1782u^2t^5 + 1633u^3t^4 + 1366u^4t^3 + 1677u^5t^2 + 1363u^6t + 406u^7)s^{11} \\
& + (396t^8 + 3450ut^7 + 8220u^2t^6 + 5816u^3t^5 - 2041u^4t^4 - 1266u^5t^3 + 5406u^6t^2 + 5360u^7t + 1391u^8)s^{10} + 2(165t^9 + 2460ut^8 \\
& + 7356u^2t^7 + 5316u^3t^6 - 8202u^4t^5 - 15297u^5t^4 - 5650u^6t^3 + 4428u^7t^2 + 4099u^8t + 897u^9)s^9 + (187t^{10} + 5044ut^9 + 19227u^2t^8 \\
& + 21984u^3t^7 - 15915u^4t^6 - 62664u^5t^5 - 56568u^6t^4 - 10620u^7t^3 + 14826u^8t^2 + 9784u^9t + 1783u^{10})s^8 + 2(33t^{11} + 1640ut^{10} \\
& + 8324u^2t^9 + 17396u^3t^8 + 12447u^4t^7 - 14606u^5t^6 - 35999u^6t^5 - 24042u^7t^4 + 1442u^8t^3 + 9648u^9t^2 + 4481u^{10}t + 668u^{11})s^7 \\
& + (11t^{12} + 1158ut^{11} + 8506u^2t^{10} + 34618u^3t^9 + 71793u^4t^8 + 62258u^5t^7 - 9538u^6t^6 - 52674u^7t^5 - 20480u^8t^4 + 18332u^9t^3 \\
& + 18756u^{10}t^2 + 6076u^{11}t + 702u^{12})s^6 + 2u(81t^{12} + 1047ut^{11} + 10102u^2t^{10} + 35002u^3t^9 + 52863u^4t^8 + 30585u^5t^7 - 6576u^6t^6 \\
& - 11010u^7t^5 + 6574u^8t^4 + 12427u^9t^3 + 6297u^{10}t^2 + 1397u^{11}t + 113u^{12})s^5 + u^2(129t^{12} + 6282ut^{11} + 32372u^2t^{10} + 66938u^3t^9 \\
& + 63533u^4t^8 + 21894u^5t^7 + 1543u^6t^6 + 16366u^7t^5 + 25835u^8t^4 + 16336u^9t^3 + 5137u^{10}t^2 + 760u^{11}t + 33u^{12})s^4 + 2tu^3(398t^{11} \\
& + 3081ut^{10} + 9304u^2t^9 + 14236u^3t^8 + 12582u^4t^7 + 9212u^5t^6 + 9802u^6t^5 + 10293u^7t^4 + 6959u^8t^3 + 2766u^9t^2 + 591u^{10}t + 48u^{11})s^3 \\
& + t^2u^4(t+u)^2(129t^8 + 1620ut^7 + 3541u^2t^6 + 3536u^3t^5 + 3022u^4t^4 + 2792u^5t^3 + 1912u^6t^2 + 746u^7t + 126u^8)s^2 + 2t^3u^5(t+u)^3(81t^6 \\
& + 276ut^5 + 227u^2t^4 + 155u^3t^3 + 173u^4t^2 + 112u^5t + 38u^6)s + t^4u^6(t+u)^4(11t^4 - 2ut^3 + 15u^2t^2 + 14u^3t + 19u^4)H(0, y)H(0, 1, z) \\
& - 18s^2t^2u^2(t+u)^2((47t^4 + 116ut^3 + 144u^2t^2 + 96u^3t + 39u^4)s^{16} + 2(211t^5 + 697ut^4 + 1032u^2t^3 + 886u^3t^2 + 487u^4t + 147u^5)s^{15} \\
& + 3(587t^6 + 2466ut^5 + 4371u^2t^4 + 4476u^3t^3 + 3059u^4t^2 + 1466u^5t + 355u^6)s^{14} + 2(2246t^7 + 11795ut^6 + 25344u^2t^5 + 30555u^3t^4 \\
& + 24384u^4t^3 + 14649u^5t^2 + 6280u^6t + 1255u^7)s^{13} + (7761t^8 + 49924ut^7 + 132409u^2t^6 + 195056u^3t^5 + 184034u^4t^4 + 125820u^5t^3 \\
& + 68009u^6t^2 + 25468u^7t + 4325u^8)s^{12} + 6(1587t^9 + 12289ut^8 + 40330u^2t^7 + 74208u^3t^6 + 86445u^4t^5 + 69435u^5t^4 + 42172u^6t^3 \\
& + 20076u^7t^2 + 6418u^8t + 944u^9)s^{11} + (8447t^{10} + 78224ut^9 + 319917u^2t^8 + 731786u^3t^7 + 1046888u^4t^6 + 1017372u^5t^5 + 727368u^6t^4 \\
& + 404718u^7t^3 + 167685u^8t^2 + 44164u^9t + 5599u^{10})s^{10} + 2(2688t^{11} + 30091ut^{10} + 156379u^2t^9 + 443281u^3t^8 + 763361u^4t^7 \\
& + 878974u^5t^6 + 745371u^6t^5 + 500624u^7t^4 + 259751u^8t^3 + 91571u^9t^2 + 19006u^{10}t + 2015u^{11})s^9 + 3(784t^{12} + 11080ut^{11} + 75305u^2t^{10} \\
& + 263492u^3t^9 + 545731u^4t^8 + 746656u^5t^7 + 740518u^6t^6 + 577912u^7t^5 + 364335u^8t^4 + 170508u^9t^3 + 50345u^{10}t^2 + 7940u^{11}t \\
& + 660u^{12})s^8 + 2(318t^{13} + 6360ut^{12} + 59340u^2t^{11} + 252696u^3t^{10} + 631038u^4t^9 + 1061526u^5t^8 + 1285210u^6t^7 + 1158562u^7t^6 \\
& + 806991u^8t^5 + 444563u^9t^4 + 181058u^{10}t^3 + 45120u^{11}t^2 + 5167u^{12}t + 295u^{13})s^7 + (80t^{14} + 3066ut^{13} + 43714u^2t^{12} + 225298u^3t^{11} \\
& + 680647u^4t^{10} + 1441224u^5t^9 + 2222801u^6t^8 + 2456276u^7t^7 + 1932681u^8t^6 + 1122364u^9t^5 + 510799u^{10}t^4 + 177102u^{11}t^3 \\
& + 37210u^{12}t^2 + 2790u^{13}t + 80u^{14})s^6 + 6tu(58t^{13} + 1689u^2t^{12} + 11116u^3t^{11} + 42847u^4t^{10} + 116103u^5t^9 + 225254u^6t^8 + 308029u^7t^7 \\
& + 293932u^8t^6 + 196649u^9t^5 + 94795u^{10}t^4 + 34537u^{11}t^3 + 9491u^{12}t^2 + 1574u^{13}t + 58u^{14})s^5 + t^2u^2(1092t^{12} + 11428ut^{11} + 67756u^2t^{10} \\
& + 245052u^3t^9 + 575825u^4t^8 + 929600u^5t^7 + 1064520u^6t^6 + 875584u^7t^5 + 515905u^8t^4 + 213096u^9t^3 + 59096u^{10}t^2 + 10508u^{11}t \\
& + 1092u^{12})s^4 + 2t^3u^3(394t^{11} + 5820ut^{10} + 29696u^2t^9 + 83756u^3t^8 + 156154u^4t^7 + 208169u^5t^6 + 204213u^6t^5 + 148024u^7t^4 \\
& + 77656u^8t^3 + 27425u^9t^2 + 5475u^{10}t + 394u^{11})s^3 + 6t^4u^4(t+u)^2(173t^8 + 987ut^7 + 2643u^2t^6 + 4684u^3t^5 + 5690u^4t^4 + 4568u^5t^3 \\
& + 2519u^6t^2 + 941u^7t + 173u^8)s^2 + 2t^5u^5(t+u)^3(150t^6 + 629ut^5 + 1361u^2t^4 + 1851u^3t^3 + 1353u^4t^2 + 606u^5t + 150u^6)s \\
& + 66t^6u^6(t+u)^4(t^2 + ut + u^2)^2H(2, y)H(0, 1, z) - 3s^2(s+t)^2u^2(t+u)^2((259t^6 + 616ut^5 + 426u^2t^4 - 68u^3t^3 + 109u^4t^2 + 300u^5t \\
& + 120u^6)s^{14} + 2(774t^7 + 2870ut^6 + 3872u^2t^5 + 1903u^3t^4 + 425u^4t^3 + 1339u^5t^2 + 1395u^6t + 420u^7)s^{13} + (4367t^8 + 21396ut^7 \\
& + 40759u^2t^6 + 37858u^3t^5 + 19215u^4t^4 + 14984u^5t^3 + 18489u^6t^2 + 11430u^7t + 2640u^8)s^{12} + 2(3840t^9 + 23121ut^8 + 56244u^2t^7 \\
& + 72977u^3t^6 + 57956u^4t^5 + 40878u^5t^4 + 39401u^6t^3 + 31286u^7t^2 + 13545u^8t + 2460u^9)s^{11} + 2(4602t^{10} + 33792ut^9 + 102876u^2t^8 \\
& + 170653u^3t^7 + 175620u^4t^6 + 137297u^5t^5 + 118565u^6t^4 + 104385u^7t^3 + 62005u^8t^2 + 20475u^9t + 3000u^{10})s^{10} + 2(3840t^{11} \\
& + 35847ut^{10} + 140082u^2t^9 + 290657u^3t^8 + 356593u^4t^7 + 294815u^5t^6 + 230739u^6t^5 + 215383u^7t^4 + 164395u^8t^3 + 77358u^9t^2 \\
& + 20475u^{10}t + 2460u^{11})s^9 + (4367t^{12} + 55904ut^{11} + 291138u^2t^{10} + 756156u^3t^9 + 1095009u^4t^8 + 963078u^5t^7 + 649134u^6t^6 \\
& + 554262u^7t^5 + 519114u^8t^4 + 328790u^9t^3 + 124010u^{10}t^2 + 27090u^{11}t + 2640u^{12})s^8 + 2(774t^{13} + 15265ut^{12} + 110242u^2t^{11} \\
& + 363648u^3t^{10} + 642258u^4t^9 + 661734u^5t^8 + 447563u^6t^7 + 300068u^7t^6 + 277131u^8t^5 + 215383u^9t^4 + 104385u^{10}t^3 + 31286u^{11}t^2 \\
& + 5715u^{12}t + 420u^{13})s^7 + (259t^{14} + 10260ut^{13} + 111068u^2t^{12} + 486996u^3t^{11} + 1107162u^4t^{10} + 1479900u^5t^9 + 1291792u^6t^8 \\
& + 895126u^7t^7 + 649134u^8t^6 + 461478u^9t^5 + 237130u^{10}t^4 + 78802u^{11}t^3 + 18489u^{12}t^2 + 2790u^{13}t + 120u^{14})s^6 + 2tu(777t^{13} \\
& + 16074ut^{12} + 104819u^2t^{11} + 330308u^3t^{10} + 608514u^4t^9 + 739950u^5t^8 + 661734u^6t^7 + 481539u^7t^6 + 294815u^8t^5 + 137297u^9t^4
\end{aligned}$$

$$\begin{aligned}
& + 40878u^{10}t^3 + 7492u^{11}t^2 + 1339u^{12}t + 150u^{13})s^5 + t^2u^2(3885t^{12} + 50940ut^{11} + 249466u^2t^{10} + 660616u^3t^9 + 1107162u^4t^8 \\
& + 1284516u^5t^7 + 1095009u^6t^6 + 713186u^7t^5 + 351240u^8t^4 + 115912u^9t^3 + 19215u^{10}t^2 + 850u^{11}t + 109u^{12})s^4 + 2t^3u^3(2590t^{11} \\
& + 25470ut^{10} + 104819u^2t^9 + 243498u^3t^8 + 363648u^4t^7 + 378078u^5t^6 + 290657u^6t^5 + 170653u^7t^4 + 72977u^8t^3 + 18929u^9t^2 + 1903u^{10}t \\
& - 34u^{11})s^3 + t^4u^4(t+u)^2(3885t^8 + 24378u^7t^7 + 58427u^2t^6 + 79252u^3t^5 + 74207u^4t^4 + 52498u^5t^3 + 26549u^6t^2 + 6892u^7t + 426u^8)s^2 \\
& + 2t^5u^5(t+u)^3(777t^6 + 2799u^5t^5 + 4537u^2t^4 + 5167u^3t^3 + 3936u^4t^2 + 1946u^5t + 308u^6)s + t^6u^6(t+u)^4(259t^4 + 512ut^3 + 765u^2t^2 \\
& + 512u^3t + 259u^4)H(0, 2, y) - 18s^2t^2u^2(t+u)^3(2t(7t^2 + 15u^2 + 12u^2)s^{16} + 12(8t^4 + 24ut^3 + 29u^2t^2 + 12u^3t - u^4)s^{15} + 3(101t^5 \\
& + 423ut^4 + 720u^2t^3 + 556u^3t^2 + 111u^4t - 31u^5)s^{14} + (598t^6 + 3066ut^5 + 7134u^2t^4 + 8992u^3t^3 + 5154u^4t^2 + 510u^5t - 318u^6)s^{13} \\
& + (851t^7 + 4495u^6t^6 + 13290u^2t^5 + 25506u^3t^4 + 26949u^4t^3 + 12309u^5t^2 + 688u^6t - 652u^7)s^{12} + 6(158t^8 + 586ut^7 + 2628u^2t^6 \\
& + 7708u^3t^5 + 11649u^4t^4 + 9092u^5t^3 + 3324u^6t^2 + 218u^7t - 155u^8)s^{11} + (851t^9 - 417ut^8 + 9564u^2t^7 + 62150u^3t^6 + 123813u^4t^5 \\
& + 121269u^5t^4 + 67982u^6t^3 + 23208u^7t^2 + 2838u^8t - 1002u^9)s^{10} + 2(299t^{10} - 2075ut^9 - 1896u^2t^8 + 23751u^3t^7 + 72903u^4t^6 \\
& + 97515u^5t^5 + 71423u^6t^4 + 31963u^7t^3 + 10800u^8t^2 + 1966u^9t - 409u^{10})s^9 + 3(101t^{11} - 1463ut^{10} - 3896u^2t^9 + 208u^3t^8 + 20429u^4t^7 \\
& + 58669u^5t^6 + 80268u^6t^5 + 55172u^7t^4 + 19400u^8t^3 + 4832u^9t^2 + 1000u^{10}t - 156u^{11})s^8 + 2(48t^{12} - 1128ut^{11} - 4410u^2t^{10} \\
& - 17090u^3t^9 - 31983u^4t^8 + 6084u^5t^7 + 100874u^6t^6 + 143160u^7t^5 + 88338u^8t^4 + 23800u^9t^3 + 2622u^{10}t^2 + 582u^{11}t - 81u^{12})s^7 \\
& + (14t^{13} - 572ut^{12} - 3036u^2t^{11} - 35818u^3t^{10} - 106376u^4t^9 - 101688u^5t^8 + 48822u^6t^7 + 213630u^7t^6 + 239397u^8t^5 + 134809u^9t^4 \\
& + 31274u^{10}t^3 - 36u^{11}t^2 + 157u^{12}t - 25u^{13})s^6 - 6tu(8t^{12} + 37ut^{11} + 3213u^2t^{10} + 11984u^3t^9 + 14592u^4t^8 + 19875u^5t^7 - 12914u^6t^6 \\
& - 20563u^7t^5 - 20499u^8t^4 - 11612u^9t^3 - 2423u^{10}t^2 + 147u^{11}t + 3u^{12})s^5 + t^2u^2(102t^{11} - 5234ut^{10} - 25530u^2t^9 - 39126u^3t^8 \\
& - 12408u^4t^7 + 24648u^5t^6 + 35505u^6t^5 + 40505u^7t^4 + 40476u^8t^3 + 21240u^9t^2 + 3629u^{10}t - 267u^{11})s^4 + 2t^3u^3(-266t^{10} - 1804u^9t^9 \\
& - 4752u^2t^8 - 4830u^3t^7 + 378u^4t^6 + 5301u^5t^5 + 6806u^6t^4 + 6178u^7t^3 + 3642u^8t^2 + 1119u^9t + 156u^{10})s^3 + 3t^4u^4(t+u)^2(16t^7 \\
& - 382ut^6 - 532u^2t^5 + 8u^3t^4 + 467u^4t^3 + 637u^5t^2 + 265u^6t - 71u^7)s^2 - 2t^5u^5(t+u)^3(48t^5 + 151ut^4 - 84u^2t^3 + 18u^3t^2 - 160u^4t \\
& - 15u^5)s + t^6u^7(t+u)^3(12t^3 + 3ut^2 + 2u^2t - 11u^3)H(1, z)H(0, 3, y) - 3s^2(s+t)^2u^2(t+u)^2((259t^6 + 616ut^5 + 426u^2t^4 - 68u^3t^3 \\
& + 109u^4t^2 + 300u^5t + 120u^6)s^{14} + 2(774t^7 + 2870ut^6 + 3872u^2t^5 + 1903u^3t^4 + 425u^4t^3 + 1339u^5t^2 + 1395u^6t + 420u^7)s^{13} + (4367t^8 \\
& + 21396ut^7 + 40759u^2t^6 + 37858u^3t^5 + 19215u^4t^4 + 14984u^5t^3 + 18489u^6t^2 + 11430u^7t + 2640u^8)s^{12} + 2(3840t^9 + 23121ut^8 \\
& + 56244u^2t^7 + 72977u^3t^6 + 57956u^4t^5 + 40878u^5t^4 + 39401u^6t^3 + 31286u^7t^2 + 13545u^8t + 2460u^9)s^{11} + 2(4602t^{10} + 33792ut^9 \\
& + 102876u^2t^8 + 170653u^3t^7 + 175620u^4t^6 + 137297u^5t^5 + 118565u^6t^4 + 104385u^7t^3 + 62005u^8t^2 + 20475u^9t + 3000u^{10})s^{10} \\
& + 2(3840t^{11} + 35847ut^{10} + 140082u^2t^9 + 290657u^3t^8 + 356593u^4t^7 + 294815u^5t^6 + 230739u^6t^5 + 215383u^7t^4 + 164395u^8t^3 \\
& + 77358u^9t^2 + 20475u^{10}t + 2460u^{11})s^9 + (4367t^{12} + 55904ut^{11} + 291138u^2t^{10} + 756156u^3t^9 + 1095009u^4t^8 + 963078u^5t^7 \\
& + 649134u^6t^6 + 554262u^7t^5 + 519114u^8t^4 + 328790u^9t^3 + 124010u^{10}t^2 + 27090u^{11}t + 2640u^{12})s^8 + 2(774t^{13} + 15265ut^{12} \\
& + 110242u^2t^{11} + 363648u^3t^{10} + 642258u^4t^9 + 661734u^5t^8 + 447563u^6t^7 + 300068u^7t^6 + 277131u^8t^5 + 215383u^9t^4 + 104385u^{10}t^3 \\
& + 31286u^{11}t^2 + 5715u^{12}t + 420u^{13})s^7 + (259t^{14} + 10260ut^{13} + 111068u^2t^{12} + 486996u^3t^{11} + 1107162u^4t^{10} + 1479900u^5t^9 \\
& + 1291792u^6t^8 + 895126u^7t^7 + 649134u^8t^6 + 461478u^9t^5 + 237130u^{10}t^4 + 78802u^{11}t^3 + 18489u^{12}t^2 + 2790u^{13}t + 120u^{14})s^6 \\
& + 2tu(777t^{13} + 16074ut^{12} + 104819u^2t^{11} + 330308u^3t^{10} + 608514u^4t^9 + 739950u^5t^8 + 661734u^6t^7 + 481539u^7t^6 + 294815u^8t^5 \\
& + 137297u^9t^4 + 40878u^{10}t^3 + 7492u^{11}t^2 + 1339u^{12}t + 150u^{13})s^5 + t^2u^2(3885t^{12} + 50940ut^{11} + 249466u^2t^{10} + 660616u^3t^9 \\
& + 1107162u^4t^8 + 1284516u^5t^7 + 1095009u^6t^6 + 713186u^7t^5 + 351240u^8t^4 + 115912u^9t^3 + 19215u^{10}t^2 + 850u^{11}t + 109u^{12})s^4 \\
& + 2t^3u^3(2590t^{11} + 25470ut^{10} + 104819u^2t^9 + 243498u^3t^8 + 363648u^4t^7 + 378078u^5t^6 + 290657u^6t^5 + 170653u^7t^4 + 72977u^8t^3 \\
& + 18929u^9t^2 + 1903u^{10}t - 34u^{11})s^3 + t^4u^4(t+u)^2(3885t^8 + 24378u^7t^7 + 58427u^2t^6 + 79252u^3t^5 + 74207u^4t^4 + 52498u^5t^3 \\
& + 26549u^6t^2 + 6892u^7t + 426u^8)s^2 + 2t^5u^5(t+u)^3(777t^6 + 2799u^5t^5 + 4537u^2t^4 + 5167u^3t^3 + 3936u^4t^2 + 1946u^5t + 308u^6)s \\
& + t^6u^6(t+u)^4(259t^4 + 512ut^3 + 765u^2t^2 + 512u^3t + 259u^4)H(2, 0, y) - 18s^2t^2u^2(t+u)^2((83t^4 + 224u^3t^3 + 312u^2t^2 + 224u^3t \\
& + 83u^4)s^{16} + (646t^5 + 2236ut^4 + 3738u^2t^3 + 3738u^3t^2 + 2236u^4t + 646u^5)s^{15} + 3(795t^6 + 3434u^5t^5 + 6735u^2t^4 + 8252u^3t^3 + 6735u^4t^2 \\
& + 3434u^5t + 795u^6)s^{14} + (5590t^7 + 29722ut^6 + 68154u^2t^5 + 96362u^3t^4 + 96362u^4t^3 + 68154u^5t^2 + 29722u^6t + 5590u^7)s^{13} + (9297t^8 \\
& + 59792u^7t^7 + 162893u^2t^6 + 265856u^3t^5 + 307366u^4t^4 + 265856u^5t^3 + 162893u^6t^2 + 59792u^7t + 9297u^8)s^{12} + 6(1912t^9 + 14697ut^8 \\
& + 48146u^2t^7 + 92627u^3t^6 + 123322u^4t^5 + 123322u^5t^4 + 92627u^6t^3 + 48146u^7t^2 + 14697u^8t + 1912u^9)s^{11} + (10571t^{10} + 97460ut^9 \\
& + 390525u^2t^8 + 895950u^3t^7 + 1372200u^4t^6 + 1560372u^5t^5 + 1372200u^6t^4 + 895950u^7t^3 + 390525u^8t^2 + 97460u^9t + 10571u^{10})s^{10} \\
& + 2(3555t^{11} + 40253ut^{10} + 202415u^2t^9 + 561210u^3t^8 + 989305u^4t^7 + 1257298u^5t^6 + 1257298u^6t^5 + 989305u^7t^4 + 561210u^8t^3 \\
& + 202415u^9t^2 + 40253u^{10}t + 3555u^{11})s^9 + 3(1100t^{12} + 16144u^11t + 105097u^2t^{10} + 356156u^3t^9 + 736699u^4t^8 + 1061804u^5t^7 \\
& + 1182566u^6t^6 + 1061804u^7t^5 + 736699u^8t^4 + 356156u^9t^3 + 105097u^{10}t^2 + 16144u^{11}t + 1100u^{12})s^8 + 2(471t^{13} + 10059u^12t^{12}
\end{aligned}$$



$$\begin{aligned}
& + 89007u^2t^{11} + 370856u^3t^{10} + 918809u^4t^9 + 1568172u^5t^8 + 2010976u^6t^7 + 2010976u^7t^6 + 1568172u^8t^5 + 918809u^9t^4 + 370856u^{10}t^3 \\
& + 89007u^{11}t^2 + 10059u^{12}t + 471u^{13})s^7 + (124t^{14} + 5166ut^{13} + 68942u^2t^{12} + 360694u^3t^{11} + 1093775u^4t^{10} + 2281660u^5t^9 \\
& + 3515021u^6t^8 + 4060864u^7t^7 + 3515021u^8t^6 + 2281660u^9t^5 + 1093775u^{10}t^4 + 360694u^{11}t^3 + 68942u^{12}t^2 + 5166u^{13}t + 124u^{14})s^6 \\
& + 6tu(102t^{13} + 2718u^{12} + 19299u^2t^{11} + 75952u^3t^{10} + 198691u^4t^9 + 370135u^5t^8 + 503605u^6t^7 + 503605u^7t^6 + 370135u^8t^5 \\
& + 198691u^9t^4 + 75952u^{10}t^3 + 19299u^{11}t^2 + 2718u^{12}t + 102u^{13})s^5 + t^2u^2(1752t^{12} + 21508ut^{11} + 127396u^2t^{10} + 438996u^3t^9 \\
& + 986209u^4t^8 + 1559032u^5t^7 + 1808388u^6t^6 + 1559032u^7t^5 + 986209u^8t^4 + 438996u^9t^3 + 127396u^{10}t^2 + 21508u^{11}t + 1752u^{12})s^4 \\
& + 2t^3u^3(834t^{11} + 10755ut^{10} + 52845u^2t^9 + 146657u^3t^8 + 271322u^4t^7 + 363015u^5t^6 + 363015u^6t^5 + 271322u^7t^4 + 146657u^8t^3 \\
& + 52845u^9t^2 + 10755u^{10}t + 834u^{11})s^3 + 6t^4u^4(t+u)^2(283t^8 + 1733ut^7 + 4779u^2t^6 + 8360u^3t^5 + 10092u^4t^4 + 8360u^5t^3 + 4779u^6t^2 \\
& + 1733u^7t + 283u^8)s^2 + 2t^5u^5(t+u)^3(282t^6 + 1178u^5t^5 + 2417u^2t^4 + 3162u^3t^3 + 2417u^4t^2 + 1178u^5t + 282u^6)s + 110t^6u^6(t+u)^4(t^2 \\
& + ut + u^2)^2H(1, z)H(2, 3, y) + 9s^2(t+u)^2(2(20t^8 + 50ut^7 + 21u^2t^6 - 82u^3t^5 - 102u^4t^4 - 82u^5t^3 + 21u^6t^2 + 50u^7t + 20u^8)s^{16} \\
& + 2(140t^9 + 505u^8t^8 + 568u^2t^7 - 298u^3t^6 - 1069u^4t^5 - 1069u^5t^4 - 298u^6t^3 + 568u^7t^2 + 505u^8t + 140u^9)s^{15} + (880t^{10} + 4370ut^9 \\
& + 8221u^2t^8 + 4262u^3t^7 - 6199u^4t^6 - 10932u^5t^5 - 6199u^6t^4 + 4262u^7t^3 + 8221u^8t^2 + 4370u^9t + 880u^{10})s^{14} + 2(820t^{11} + 5395u^{10}t^{10} \\
& + 14563u^2t^9 + 17988u^3t^8 + 5650u^4t^7 - 8508u^5t^6 - 8508u^6t^5 + 5650u^7t^4 + 17988u^8t^3 + 14563u^9t^2 + 5395u^{10}t + 820u^{11})s^{13} \\
& + (2000t^{12} + 16930ut^{11} + 60889u^2t^{10} + 115200u^3t^9 + 112888u^4t^8 + 52018u^5t^7 + 18062u^6t^6 + 52018u^7t^5 + 112888u^8t^4 + 115200u^9t^3 \\
& + 60889u^{10}t^2 + 16930u^{11}t + 2000u^{12})s^{12} + 2(820t^{13} + 8825u^2t^{12} + 40630u^2t^{11} + 106430u^3t^{10} + 162506u^4t^9 + 145433u^5t^8 \\
& + 94054u^6t^7 + 94054u^7t^6 + 145433u^8t^5 + 162506u^9t^4 + 106430u^{10}t^3 + 40630u^{11}t^2 + 8825u^{12}t + 820u^{13})s^{11} + (880t^{14} + 12310ut^{13} \\
& + 71305u^2t^{12} + 252860u^3t^{11} + 542940u^4t^{10} + 672624u^5t^9 + 495141u^6t^8 + 346704u^7t^7 + 495141u^8t^6 + 672624u^9t^5 + 542940u^{10}t^4 \\
& + 252860u^{11}t^3 + 71305u^{12}t^2 + 12310u^{13}t + 880u^{14})s^{10} + 2(140t^{15} + 2785u^2t^{14} + 20491u^2t^{13} + 99450u^3t^{12} + 294436u^4t^{11} \\
& + 490859u^5t^{10} + 448931u^6t^9 + 254956u^7t^8 + 254956u^8t^7 + 448931u^9t^6 + 490859u^{10}t^5 + 294436u^{11}t^4 + 99450u^{12}t^3 + 20491u^{13}t^2 \\
& + 2785u^{14}t + 140u^{15})s^9 + (40t^{16} + 1490ut^{15} + 14845u^2t^{14} + 102820u^3t^{13} + 419280u^4t^{12} + 950788u^5t^{11} + 1225773u^6t^{10} \\
& + 975710u^7t^9 + 743060u^8t^8 + 975710u^9t^7 + 1225773u^{10}t^6 + 950788u^{11}t^5 + 419280u^{12}t^4 + 102820u^{13}t^3 + 14845u^{14}t^2 + 1490u^{15}t \\
& + 40u^{16})s^8 + 2tu(90t^{15} + 1540u^2t^{14} + 16932u^2t^{13} + 96123u^3t^{12} + 304282u^4t^{11} + 583798u^5t^{10} + 762212u^6t^9 + 803305u^7t^8 \\
& + 803305u^8t^7 + 762212u^9t^6 + 583798u^{10}t^5 + 304282u^{11}t^4 + 96123u^{12}t^3 + 16932u^{13}t^2 + 1540u^{14}t + 90u^{15})s^7 + t^2u^2(282t^{14} \\
& + 6622ut^{13} + 54887u^2t^{12} + 264008u^3t^{11} + 776536u^4t^{10} + 1517240u^5t^9 + 2171441u^6t^8 + 2431080u^7t^7 + 2171441u^8t^6 + 1517240u^9t^5 \\
& + 776536u^{10}t^4 + 264008u^{11}t^3 + 54887u^{12}t^2 + 6622u^{13}t + 282u^{14})s^6 + 2t^3u^3(298t^{13} + 4418ut^{12} + 40731u^2t^{11} + 190625u^3t^{10} \\
& + 505964u^4t^9 + 877790u^5t^8 + 1117090u^6t^7 + 1117090u^7t^6 + 877790u^8t^5 + 505964u^9t^4 + 190625u^{10}t^3 + 40731u^{11}t^2 + 4418u^{12}t \\
& + 298u^{13})s^5 + t^4u^4(536t^{12} + 16810ut^{11} + 131975u^2t^{10} + 463360u^3t^9 + 936996u^4t^8 + 1292362u^5t^7 + 1406138u^6t^6 + 1292362u^7t^5 \\
& + 936996u^8t^4 + 463360u^9t^3 + 131975u^{10}t^2 + 16810u^{11}t + 536u^{12})s^4 + 2t^5u^5(848t^{11} + 13094ut^{10} + 64600u^2t^9 + 162207u^3t^8 \\
& + 255217u^4t^7 + 298424u^5t^6 + 298424u^6t^5 + 255217u^7t^4 + 162207u^8t^3 + 64600u^9t^2 + 13094u^{10}t + 848u^{11})s^3 + t^6u^6(t+u)^2(2062t^8 \\
& + 13122ut^7 + 32971u^2t^6 + 48846u^3t^5 + 54292u^4t^4 + 48846u^5t^3 + 32971u^6t^2 + 13122u^7t + 2062u^8)s^2 + 4t^7u^7(t+u)^3(158t^6 \\
& + 746ut^5 + 1500u^2t^4 + 1923u^3t^3 + 1500u^4t^2 + 746u^5t + 158u^6)s + 8t^8u^8(t+u)^4(23t^4 + 45ut^3 + 67u^2t^2 + 45u^3t + 23u^4)H(3, 2, y) \\
& - 36s^2t^2u^3(t+u)^2(-12t(4t^2 + 7ut + 4u^2)s^{16} - (413t^4 + 1112ut^3 + 1066u^2t^2 + 344u^3t - 23u^4)s^{15} - 3(549t^5 + 2080ut^4 + 2910u^2t^3 \\
& + 1760u^3t^2 + 293u^4t - 64u^5)s^{14} - (3849t^6 + 19818ut^5 + 38435u^2t^4 + 35276u^3t^3 + 14007u^4t^2 + 482u^5t - 715u^6)s^{13} - (5797t^7 \\
& + 40039u^6t^6 + 104248u^2t^5 + 133574u^3t^4 + 86245u^4t^3 + 21235u^5t^2 - 2834u^6t - 1572u^7)s^{12} - 3(1839t^8 + 18438ut^7 + 63926u^2t^6 \\
& + 107954u^3t^5 + 97302u^4t^4 + 43534u^5t^3 + 4746u^6t^2 - 2870u^7t - 757u^8)s^{11} - (2469t^9 + 52233ut^8 + 250929u^2t^7 + 546879u^3t^6 \\
& + 638973u^4t^5 + 405133u^5t^4 + 113599u^6t^3 - 8307u^7t^2 - 12530u^8t - 2258u^9)s^{10} + (985t^{10} - 31352ut^9 - 228083u^2t^8 - 646444u^3t^7 \\
& - 969791u^4t^6 - 819288u^5t^5 - 357472u^6t^4 - 38248u^7t^3 + 28876u^8t^2 + 11404u^9t + 1557u^{10})s^9 + 3(727t^{11} - 3289ut^{10} - 45068u^2t^9 \\
& - 168873u^3t^8 - 330122u^4t^7 - 375394u^5t^6 - 241202u^6t^5 - 66685u^7t^4 + 10259u^8t^3 + 10981u^9t^2 + 2326u^{10}t + 240u^{11})s^8 + (1386t^{12} \\
& - 6ut^{11} - 44480u^2t^{10} - 241022u^3t^9 - 645063u^4t^8 - 1001980u^5t^7 - 922078u^6t^6 - 455700u^7t^5 - 58195u^8t^4 + 50450u^9t^3 + 22836u^{10}t^2 \\
& + 2866u^{11}t + 202u^{12})s^7 + (420t^{13} + 1149ut^{12} + 3u^2t^{11} - 48559u^3t^{10} - 253354u^4t^9 - 575952u^5t^8 - 717884u^6t^7 - 512534u^7t^6 \\
& - 180305u^8t^5 + 7313u^9t^4 + 31999u^{10}t^3 + 10093u^{11}t^2 + 729u^{12}t + 26u^{13})s^6 + 3t(16t^{13} + 94ut^{12} + 2346u^2t^{11} + 5138u^3t^{10} - 15062u^4t^9 \\
& - 74024u^5t^8 - 122999u^6t^7 - 106460u^7t^6 - 49523u^8t^5 - 8048u^9t^4 + 4593u^{10}t^3 + 3534u^{11}t^2 + 893u^{12}t + 30u^{13})s^5 + t^2u( - 6t^{12} \\
& + 2684ut^{11} + 12044u^2t^{10} + 7299u^3t^9 - 50331u^4t^8 - 127806u^5t^7 - 131304u^6t^6 - 58843u^7t^5 + 1403u^8t^4 + 13260u^9t^3 + 6238u^{10}t^2 \\
& + 1774u^{11}t + 336u^{12})s^4 + 2t^3u^2(166t^{11} + 1146u^2t^{10} + 2486u^2t^9 - 448u^3t^8 - 9790u^4t^7 - 15423u^5t^6 - 8416u^6t^5 + 3041u^7t^4
\end{aligned}$$

$$\begin{aligned}
& + 7002u^8t^3 + 4035u^9t^2 + 960u^{10}t + 57u^{11})s^3 + 3t^4 u^3(t+u)^2(15t^8 + 240ut^7 + 369u^2t^6 - u^3t^5 - 172u^4t^4 + 126u^5t^3 + 429u^6t^2 \\
& + 355u^7t + 103u^8)s^2 + t^5u^4(t+u)^3(90t^6 + 272ut^5 + 116u^2t^4 + 114u^3t^3 + 135u^4t^2 + 117u^5t + 66u^6) s + t^6u^5(t+u)^4(11t^4 - 2ut^3 \\
& + 15u^2t^2 + 14u^3t + 19u^4)H(0, 0, 1, z) + 18s^2t^2(s+t)^2u^2(2(55t^6 + 282ut^5 + 849u^2t^4 + 834u^3t^3 + 876u^4t^2 + 306u^5t + 62u^6)s^{14} \\
& + 2(330t^7 + 2024ut^6 + 6897u^2t^5 + 10755u^3t^4 + 10754u^4t^3 + 8154u^5t^2 + 2583u^6t + 471u^7)s^{13} + 2(935t^8 + 6797ut^7 + 25584u^2t^6 \\
& + 52845u^3t^5 + 63698u^4t^4 + 57897u^5t^3 + 34471u^6t^2 + 10059u^7t + 1650u^8)s^{12} + 2(1650t^9 + 14229ut^8 + 58953u^2t^7 + 146657u^3t^6 \\
& + 219498u^4t^5 + 227856u^5t^4 + 180347u^6t^3 + 89007u^7t^2 + 24216u^8t + 3555u^9)s^{11} + (3960t^{10} + 40664ut^9 + 189546u^2t^8 + 542644u^3t^7 \\
& + 986209u^4t^6 + 1192146u^5t^5 + 1093775u^6t^4 + 741712u^7t^3 + 315291u^8t^2 + 80506u^9t + 10571u^{10})s^{10} + 2(1650t^{11} + 20332u^2t^{10} \\
& + 110712u^2t^9 + 363015u^3t^8 + 779516u^4t^7 + 1110405u^5t^6 + 1140830u^6t^5 + 918809u^7t^4 + 534234u^8t^3 + 202415u^9t^2 + 48730u^{10}t \\
& + 5736u^{11})s^9 + (1870t^{12} + 28458ut^{11} + 189546u^2t^{10} + 726030u^3t^9 + 1808388u^4t^8 + 3021630u^5t^7 + 3515021u^6t^6 + 3136344u^7t^5 \\
& + 2210097u^8t^4 + 1122420u^9t^3 + 390525u^{10}t^2 + 88182u^{11}t + 9297u^{12})s^8 + 2(330t^{13} + 6797ut^{12} + 58953u^2t^{11} + 271322u^3t^{10} \\
& + 779516u^4t^9 + 1510815u^5t^8 + 2030432u^6t^7 + 2010976u^7t^6 + 1592706u^8t^5 + 989305u^9t^4 + 447975u^{10}t^3 + 144438u^{11}t^2 + 29896u^{12}t \\
& + 2795u^{13})s^7 + (110t^{14} + 4048ut^{13} + 51168u^2t^{12} + 293314u^3t^{11} + 986209u^4t^{10} + 2220810u^5t^9 + 3515021u^6t^8 + 4021952u^7t^7 \\
& + 3547698u^8t^6 + 2514596u^9t^5 + 1372200u^{10}t^4 + 555762u^{11}t^3 + 162893u^{12}t^2 + 29722u^{13}t + 2385u^{14})s^6 + 2u(282t^{14} + 6897ut^{13} \\
& + 52845u^2t^{12} + 219498u^3t^{11} + 596073u^4t^{10} + 1140830u^5t^9 + 1568172u^6t^8 + 1592706u^7t^7 + 1257298u^8t^6 + 780186u^9t^5 + 369966u^{10}t^4 \\
& + 132928u^{11}t^3 + 34077u^{12}t^2 + 5151u^{13}t + 323u^{14})s^5 + u^2(1698t^{14} + 21510u^2t^{13} + 127396u^2t^{12} + 455712u^3t^{11} + 1093775u^4t^{10} \\
& + 1837618u^5t^9 + 2210097u^6t^8 + 1978610u^7t^7 + 1372200u^8t^6 + 739932u^9t^5 + 307366u^{10}t^4 + 96362u^{11}t^3 + 20205u^{12}t^2 + 2236u^{13}t \\
& + 83u^{14})s^4 + 2tu^3(834t^{13} + 10754ut^{12} + 57897u^2t^{11} + 180347u^3t^{10} + 370856u^4t^9 + 534234u^5t^8 + 561210u^6t^7 + 447975u^7t^6 \\
& + 277881u^8t^5 + 132928u^9t^4 + 48181u^{10}t^3 + 12378u^{11}t^2 + 1869u^{12}t + 112u^{13})s^3 + t^2u^4(t+u)^2(1752t^{10} + 12804ut^9 + 41582u^2t^8 \\
& + 82046u^3t^7 + 109617u^4t^6 + 103550u^5t^5 + 73808u^6t^4 + 37710u^7t^3 + 13665u^8t^2 + 3114u^9t + 312u^{10})s^2 + 2t^3u^5(t+u)^3(306t^8 \\
& + 1665ut^7 + 4146u^2t^6 + 6477u^3t^5 + 6719u^4t^4 + 4996u^5t^3 + 2469u^6t^2 + 782u^7t + 112u^8)s + t^4u^6(t+u)^6(124t^4 + 198ut^3 + 252u^2t^2 \\
& + 148u^3t + 83u^4)H(0, 1, 0, y) - 18s^2t^2u^2(t+u)^3(2t(7t^2 + 15ut + 12u^2)s^{16} + 12(8t^4 + 24ut^3 + 29u^2t^2 + 12u^3t - u^4)s^{15} \\
& + 3(101t^5 + 423u^4t^4 + 720u^2t^3 + 556u^3t^2 + 111u^4t - 31u^5)s^{14} + (598t^6 + 3066ut^5 + 7134u^2t^4 + 8992u^3t^3 + 5154u^4t^2 + 510u^5t \\
& - 318u^6)s^{13} + (851t^7 + 4495ut^6 + 13290u^2t^5 + 25506u^3t^4 + 26949u^4t^3 + 12309u^5t^2 + 688u^6t - 652u^7)s^{12} + 6(158t^8 + 586u^6t^7 \\
& + 2628u^2t^6 + 7708u^3t^5 + 11649u^4t^4 + 9092u^5t^3 + 3324u^6t^2 + 218u^7t - 155u^8)s^{11} + (851t^9 - 417ut^8 + 9564u^2t^7 + 62150u^3t^6 \\
& + 123813u^4t^5 + 121269u^5t^4 + 67982u^6t^3 + 23208u^7t^2 + 2838u^8t - 1002u^9)s^{10} + 2(299t^{10} - 2075ut^9 - 1896u^2t^8 + 23751u^3t^7 \\
& + 72903u^4t^6 + 97515u^5t^5 + 71423u^6t^4 + 31963u^7t^3 + 10800u^8t^2 + 1966u^9t - 409u^{10})s^9 + 3(101t^{11} - 1463ut^{10} - 3896u^2t^9 \\
& + 208u^3t^8 + 20429u^4t^7 + 58669u^5t^6 + 80268u^6t^5 + 55172u^7t^4 + 19400u^8t^3 + 4832u^9t^2 + 1000u^{10}t - 156u^{11})s^8 + 2(48t^{12} - 1128ut^{11} \\
& - 4410u^2t^{10} - 17090u^3t^9 - 31983u^4t^8 + 6084u^5t^7 + 100874u^6t^6 + 143160u^7t^5 + 88338u^8t^4 + 23800u^9t^3 + 2622u^{10}t^2 + 582u^{11}t \\
& - 81u^{12})s^7 + (14t^{13} - 572u^2t^{12} - 3036u^2t^{11} - 35818u^3t^{10} - 106376u^4t^9 - 101688u^5t^8 + 48822u^6t^7 + 213630u^7t^6 + 239397u^8t^5 \\
& + 134809u^9t^4 + 31274u^{10}t^3 - 36u^{11}t^2 + 157u^{12}t - 25u^{13})s^6 - 6tu(8t^{12} + 37u^2t^{11} + 3213u^2t^{10} + 11984u^3t^9 + 14592u^4t^8 + 1987u^5t^7 \\
& - 12914u^6t^6 - 20563u^7t^5 - 20499u^8t^4 - 11612u^9t^3 - 2423u^{10}t^2 + 147u^{11}t + 3u^{12})s^5 + t^2u^2(102t^{11} - 5234ut^{10} - 25530u^2t^9 \\
& - 39126u^3t^8 - 12408u^4t^7 + 24648u^5t^6 + 35505u^6t^5 + 40505u^7t^4 + 40476u^8t^3 + 21240u^9t^2 + 3629u^{10}t - 267u^{11})s^4 + 2t^3u^3(- \\
& 266t^{10} - 1804ut^9 - 4752u^2t^8 - 4830u^3t^7 + 378u^4t^6 + 5301u^5t^5 + 6806u^6t^4 + 6178u^7t^3 + 3642u^8t^2 + 1119u^9t + 156u^{10})s^3 \\
& + 3t^4u^4(t+u)^2(16t^7 - 382ut^6 - 532u^2t^5 + 8u^3t^4 + 467u^4t^3 + 637u^5t^2 + 265u^6t - 71u^7)s^2 - 2t^5u^5(t+u)^3(48t^5 + 151ut^4 \\
& - 84u^2t^3 + 18u^3t^2 - 160u^4t - 15u^5)s + t^6u^7(t+u)^3(12t^3 + 3ut^2 + 2u^2t - 11u^3)H(0, 3, 2, y) - 18s^2t^2u^2(t+u)^2((55t^4 \\
& + 148ut^3 + 192u^2t^2 + 128u^3t + 47u^4)s^{16} + 2(232t^5 + 807ut^4 + 1262u^2t^3 + 1126u^3t^2 + 612u^4t + 173u^5)s^{15} + 6(305t^6 + 1324ut^5 \\
& + 2458u^2t^4 + 2648u^3t^3 + 1862u^4t^2 + 872u^5t + 201u^6)s^{14} + 2(2230t^7 + 11932ut^6 + 26409u^2t^5 + 33217u^3t^4 + 27682u^4t^3 \\
& + 16830u^5t^2 + 7005u^6t + 1347u^7)s^{13} + (7450t^8 + 48274ut^7 + 129744u^2t^6 + 195540u^3t^5 + 190555u^4t^4 + 134098u^5t^3 + 72590u^6t^2 \\
& + 26532u^7t + 4375u^8)s^{12} + 6(1486t^9 + 11488ut^8 + 37756u^2t^7 + 69937u^3t^6 + 82622u^4t^5 + 67718u^5t^4 + 41832u^6t^3 + 19931u^7t^2 \\
& + 6288u^8t + 910u^9)s^{11} + (7744t^{10} + 71242ut^9 + 290076u^2t^8 + 661446u^3t^7 + 946629u^4t^6 + 926538u^5t^5 + 671989u^6t^4 + 379294u^7t^3 \\
& + 157923u^8t^2 + 41472u^9t + 5271u^{10})s^{10} + 2(2410t^{11} + 26794ut^{10} + 138966u^2t^9 + 391138u^3t^8 + 666867u^4t^7 + 763472u^5t^6 \\
& + 652628u^6t^5 + 448145u^7t^4 + 237429u^8t^3 + 84416u^9t^2 + 17568u^{10}t + 1903u^{11})s^9 + 3(685t^{12} + 9638ut^{11} + 66160u^2t^{10} + 229988u^3t^9 \\
& + 468878u^4t^8 + 632074u^5t^7 + 626493u^6t^6 + 499908u^7t^5 + 326013u^8t^4 + 156448u^9t^3 + 46699u^{10}t^2 + 7420u^{11}t + 638u^{12})s^8 \\
& + 2(270t^{13} + 5385ut^{12} + 51810u^2t^{11} + 219533u^3t^{10} + 538700u^4t^9 + 893700u^5t^8 + 1082558u^6t^7 + 993074u^7t^6 + 712998u^8t^5 \\
& + 405820u^9t^4 + 169330u^{10}t^3 + 42843u^{11}t^2 + 4984u^{12}t + 295u^{13})s^7 + (66t^{14} + 2518ut^{13} + 38032u^2t^{12} + 195010u^3t^{11} + 579501u^4t^{10}
\end{aligned}$$

$$\begin{aligned}
& + 1219748u^5t^9 + 1901521u^6t^8 + 2145380u^7t^7 + 1729402u^8t^6 + 1029790u^9t^5 + 480198u^{10}t^4 + 170114u^{11}t^3 + 36457u^{12}t^2 + 2808u^{13}t \\
& + 83u^{14})s^6 + 6tu(46t^{13} + 1463u t^{12} + 9551u^2t^{11} + 36573u^3t^{10} + 99722u^4t^9 + 196920u^5t^8 + 275717u^6t^7 + 269768u^7t^6 + 184750u^8t^5 \\
& + 90822u^9t^4 + 33632u^{10}t^3 + 9403u^{11}t^2 + 1592u^{12}t + 61u^{13})s^5 + t^2u^2(936t^{12} + 9592ut^{11} + 58498u^2t^{10} + 216504u^3t^9 + 517783u^4t^8 \\
& + 852472u^5t^7 + 999621u^6t^6 + 842754u^7t^5 + 506934u^8t^4 + 212352u^9t^3 + 59561u^{10}t^2 + 10778u^{11}t + 1137u^{12})s^4 + 2t^3u^3(306t^{11} \\
& + 5120u t^{10} + 27107u^2t^9 + 77806u^3t^8 + 147341u^4t^7 + 200386u^5t^6 + 201078u^6t^5 + 148590u^7t^4 + 78861u^8t^3 + 28022u^9t^2 + 5655u^{10}t \\
& + 424u^{11})s^3 + 3t^4u^4(t+u)^2(312t^8 + 1862ut^7 + 5114u^2t^6 + 9264u^3t^5 + 11523u^4t^4 + 9432u^5t^3 + 5226u^6t^2 + 1942u^7t + 361u^8)s^2 \\
& + 2t^5u^5(t+u)^3(138t^6 + 635ut^5 + 1406u^2t^4 + 1938u^3t^3 + 1431u^4t^2 + 633u^5t + 159u^6)s + 3t^6u^6(t+u)^4(22t^4 + 48ut^3 + 71u^2t^2 \\
& + 46u^3t + 23u^4)H(1, 0, 1, z) - 18s^2t^2(s+t)^3u^2((11t^6 - 30ut^5 + 213u^2t^4 - 312u^3t^3 + 267u^4t^2 + 18u^5t + 25u^6)s^{13} + (31t^7 - 410ut^6 \\
& - 369u^2t^5 - 2238u^3t^4 - 3629u^4t^3 + 882u^5t^2 - 157u^6t + 162u^7)s^{12} + 6(4t^8 - 169ut^7 - 548u^2t^6 - 1214u^3t^5 - 3540u^4t^4 - 2423u^5t^3 \\
& + 6u^6t^2 - 194u^7t + 78u^8)s^{11} - 2(8t^9 + 525ut^8 + 3009u^2t^7 + 6178u^3t^6 + 20238u^4t^5 + 34836u^5t^4 + 15637u^6t^3 + 2622u^7t^2 + 1500u^8t \\
& - 409u^9)s^{10} - (47t^{10} + 414ut^9 + 4737u^2t^8 + 13612u^3t^7 + 40505u^4t^6 + 122994u^5t^5 + 134809u^6t^4 + 47600u^7t^3 + 14496u^8t^2 + 3932u^9t \\
& - 1002u^{10})s^9 - 3(13t^{11} - 178ut^{10} - 49u^2t^9 + 3534u^3t^8 + 11835u^4t^7 + 41126u^5t^6 + 79799u^6t^5 + 58892u^7t^4 + 19400u^8t^3 + 7200u^9t^2 \\
& + 946u^{10}t - 310u^{11})s^8 - 2(6t^{12} - 513ut^{11} - 2157u^2t^{10} + 378u^3t^9 + 12324u^4t^8 + 38742u^5t^7 + 106815u^6t^6 + 143160u^7t^5 \\
& + 82758u^8t^4 + 31963u^9t^3 + 11604u^{10}t^2 + 654u^{11}t - 326u^{12})s^7 + 2u(295t^{12} + 1920u t^{11} + 4830u^2t^{10} + 6204u^3t^9 + 5961u^4t^8 \\
& - 24411u^5t^7 - 100874u^6t^6 - 120402u^7t^5 - 71423u^8t^4 - 33991u^9t^3 - 9972u^{10}t^2 - 344u^{11}t + 159u^{12})s^6 + 3u(32t^{13} + 350ut^{12} \\
& + 3168u^2t^{11} + 13042u^3t^{10} + 29184u^4t^9 + 33896u^5t^8 - 4056u^6t^7 - 58669u^7t^6 - 65010u^8t^5 - 40423u^9t^4 - 18184u^{10}t^3 \\
& - 4103u^{11}t^2 - 170u^{12}t + 31u^{13})s^5 + u^2(-48t^{13} + 3608ut^{12} + 25530u^2t^{11} + 71904u^3t^{10} + 106376u^4t^9 + 63966u^5t^8 - 61287u^6t^7 \\
& - 145806u^7t^6 - 123813u^8t^5 - 69894u^9t^4 - 26949u^{10}t^3 - 5154u^{11}t^2 - 333u^{12}t + 12u^{13})s^4 + 2tu^3(266t^{12} + 2617ut^{11} + 9639u^2t^{10} \\
& + 17909u^3t^9 + 17090u^4t^8 - 312u^5t^7 - 23751u^6t^6 - 31075u^7t^5 - 23124u^8t^4 - 12753u^9t^3 - 4496u^{10}t^2 - 834u^{11}t - 72u^{12})s^3 \\
& - 6tu^4(t+u)^2(17t^{10} - 71ut^9 - 381u^2t^8 - 637u^3t^7 - 293u^4t^6 + 591u^5t^5 + 705u^6t^4 + 627u^7t^3 + 256u^8t^2 + 50u^9t + 4u^{10})s^2 \\
& + t^2u^5(t+u)^3(48t^8 + 428ut^7 + 828u^2t^6 + 573u^3t^5 - 481u^4t^4 - 687u^5t^3 - 585u^6t^2 - 198u^7t - 30u^8)s - t^3u^6(t+u)^6(14t^4 \\
& + 12ut^3 + 21u^2t^2 + 12u^3t + 14u^4)H(2, 1, 0, y) - 18s^2t^2u^2(t+u)^2((83t^4 + 224ut^3 + 312u^2t^2 + 224u^3t + 83u^4)s^{16} + (646u^5 \\
& + 2236ut^4 + 3738u^2t^3 + 3738u^3t^2 + 2236u^4t + 646u^5)s^{15} + 3(795t^6 + 3434u t^5 + 6735u^2t^4 + 8252u^3t^3 + 6735u^4t^2 + 3434u^5t \\
& + 795u^6)s^{14} + (5590t^7 + 29722ut^6 + 68154u^2t^5 + 96362u^3t^4 + 96362u^4t^3 + 68154u^5t^2 + 29722u^6t + 5590u^7)s^{13} + (9297t^8 \\
& + 59792u t^7 + 162893u^2t^6 + 265856u^3t^5 + 307366u^4t^4 + 265856u^5t^3 + 162893u^6t^2 + 59792u^7t + 9297u^8)s^{12} + 6(1912u^9 \\
& + 14697ut^8 + 48146u^2t^7 + 92627u^3t^6 + 123322u^4t^5 + 123322u^5t^4 + 92627u^6t^3 + 48146u^7t^2 + 14697u^8t + 1912u^9)s^{11} \\
& + (10571t^{10} + 97460ut^9 + 390525u^2t^8 + 895950u^3t^7 + 1372200u^4t^6 + 1560372u^5t^5 + 1372200u^6t^4 + 895950u^7t^3 + 390525u^8t^2 \\
& + 97460u^9t + 10571u^{10})s^{10} + 2(3555t^{11} + 40253ut^{10} + 202415u^2t^9 + 561210u^3t^8 + 989305u^4t^7 + 1257298u^5t^6 + 1257298u^6t^5 \\
& + 989305u^7t^4 + 561210u^8t^3 + 202415u^9t^2 + 40253u^{10}t + 3555u^{11})s^9 + 3(1100t^{12} + 16144u t^{11} + 105097u^2t^{10} + 356156u^3t^9 \\
& + 736699u^4t^8 + 1061804u^5t^7 + 1182566u^6t^6 + 1061804u^7t^5 + 736699u^8t^4 + 356156u^9t^3 + 105097u^{10}t^2 + 16144u^{11}t + 1100u^{12})s^8 \\
& + 2(471t^{13} + 10059u t^{12} + 89007u^2t^{11} + 370856u^3t^{10} + 918809u^4t^9 + 1568172u^5t^8 + 2010976u^6t^7 + 2010976u^7t^6 + 1568172u^8t^5 \\
& + 918809u^9t^4 + 370856u^{10}t^3 + 89007u^{11}t^2 + 10059u^{12}t + 471u^{13})s^7 + (124t^{14} + 5166ut^{13} + 68942u^2t^{12} + 360694u^3t^{11} \\
& + 1093775u^4t^{10} + 2281660u^5t^9 + 3515021u^6t^8 + 4060864u^7t^7 + 3515021u^8t^6 + 2281660u^9t^5 + 1093775u^{10}t^4 + 360694u^{11}t^3 \\
& + 68942u^{12}t^2 + 5166u^{13}t + 124u^{14})s^6 + 6tu(102t^{13} + 2718u t^{12} + 19299u^2t^{11} + 75952u^3t^{10} + 198691u^4t^9 + 370135u^5t^8 \\
& + 503605u^6t^7 + 503605u^7t^6 + 370135u^8t^5 + 198691u^9t^4 + 75952u^{10}t^3 + 19299u^{11}t^2 + 2718u^{12}t + 102u^{13})s^5 + t^2u^2(1752t^{12} \\
& + 21508ut^{11} + 127396u^2t^{10} + 438996u^3t^9 + 986209u^4t^8 + 1559032u^5t^7 + 1808388u^6t^6 + 1559032u^7t^5 + 986209u^8t^4 + 438996u^9t^3 \\
& + 127396u^{10}t^2 + 21508u^{11}t + 1752u^{12})s^4 + 2t^3u^3(834t^{11} + 10755ut^{10} + 52845u^2t^9 + 146657u^3t^8 + 271322u^4t^7 + 363015u^5t^6 \\
& + 363015u^6t^5 + 271322u^7t^4 + 146657u^8t^3 + 52845u^9t^2 + 10755u^{10}t + 834u^{11})s^3 + 6t^4u^4(t+u)^2(283t^8 + 1733ut^7 + 4779u^2t^6 \\
& + 8360u^3t^5 + 10092u^4t^4 + 8360u^5t^3 + 4779u^6t^2 + 1733u^7t + 283u^8)s^2 + 2t^5u^5(t+u)^3(282t^6 + 1178u t^5 + 2417u^2t^4 + 3162u^3t^3 \\
& + 2417u^4t^2 + 1178u^5t + 282u^6)s + 110t^6u^6(t+u)^4(t^2 + ut + u^2)^2H(2, 3, 2, y) \Big\} / (27s^3t^3u^3(s+t)^6(s+u)^6(t+u)^6)
\end{aligned}$$

## References

- [1] G. Aad *et al.* [ATLAS Collaboration], Phys. Lett. B **710** (2012) 538 [arXiv:1112.2194 [hep-ex]].
- [2] S. Chatrchyan *et al.* [CMS Collaboration], Phys. Rev. Lett. **108** (2012) 111801 [arXiv:1112.0688 [hep-ex]].
- [3] J. Ellis, D. S. Hwang, V. Sanz and T. You, JHEP **1211** (2012) 134 [arXiv:1208.6002 [hep-ph]].
- [4] J. Ellis, R. Fok, D. S. Hwang, V. Sanz and T. You, Eur. Phys. J. C **73**, 2488 (2013) [arXiv:1210.5229 [hep-ph]].
- [5] N. Arkani-Hamed, S. Dimopoulos and G. Dvali, Phys. Lett. B 429 (1998) 263; I. Antoniadis, N. Arkani-Hamed, S. Dimopoulos and G. Dvali, Phys. Lett. B 436 (1998) 257; N. Arkani-Hamed, S. Dimopoulos and G. Dvali, Phys. Rev. D59 (1999) 086004.
- [6] L. Randall and R. Sundrum, Phys. Rev. Lett. 83 (1999) 3370.
- [7] T. Han, J. D. Lykken and R. J. Zhang, Phys. Rev. D59 (1999) 105006
- [8] G. F. Giudice, R. Rattazzi, and J. D. Wells, Nucl. Phys. B544 (1999) 3.
- [9] J. L. Hewett, Phys. Rev. Lett. 82 (1999) 4765; Prakash Mathews, Sreerup Raychaudhuri, K. Sridhar, Phys. Lett. B450 (1999) 343; JHEP 0007 (2000) 008.
- [10] M.C. Kumar, Prakash Mathews, V. Ravindran, Satyajit Seth, Phys.Rev. D85 (2012) 094507; Li Xiao-Zhou, Duan Peng-Fei, Ma Wen-Gan, Zhang Ren-You, Guo Lei, Phys. Rev. D86 (2012) 095008.
- [11] P. Mathews, V. Ravindran, K. Sridhar and W. L. van Neerven, Nucl. Phys. B713 (2005) 333.
- [12] P. Mathews, V. Ravindran, Nucl. Phys. B753 (2006) 1.
- [13] M.C. Kumar, P. Mathews, V. Ravindran, Eur. Phys. J. C49 (2007) 599.
- [14] M.C. Kumar, P. Mathews, V. Ravindran, A. Tripathi, Phys. Lett. B672 (2009) 45.
- [15] M.C. Kumar, Prakash Mathews, V. Ravindran, Anurag Tripathi, Nucl. Phys. B818 (2009) 28.
- [16] N. Agarwal, V. Ravindran, V. K. Tiwari, and A. Tripathi, Nucl. Phys. B 830, 248 (2010).
- [17] N. Agarwal, V. Ravindran, V. K. Tiwari and A. Tripathi, Phys. Lett. B **686** (2010) 244 [arXiv:0910.1551 [hep-ph]].
- [18] N. Agarwal, V. Ravindran, V. K. Tiwari and A. Tripathi, Phys. Rev. D82 (2010) 036001.
- [19] N. Agarwal, V. Ravindran, V. K. Tiwari and A. Tripathi, Phys. Lett. B 690 (2010) 390.
- [20] R. Frederix, M. K. Mandal, P. Mathews, V. Ravindran, S. Seth, P. Torrielli and M. Zaro, JHEP 1212 (2012) 102.
- [21] R. Frederix, M. K. Mandal, P. Mathews, V. Ravindran and S. Seth, Eur. Phys. J. C **74** (2014) 2745 [arXiv:1307.7013 [hep-ph]].
- [22] S. Karg, M. Karamer, Q. Li, and D. Zeppenfeld, Phys. Rev. D 81, 094036 (2010).
- [23] X. Gao, C. S. Li, J. Gao, J. Wang and R. J. Oakes, Phys. Rev. D **81** (2010) 036008 [arXiv:0912.0199 [hep-ph]].
- [24] M. C. Kumar, P. Mathews, V. Ravindran, and S. Seth, Nucl. Phys. B847, 54 (2011); J. Phys. G 38, 055001 (2011).

- [25] D. de Florian, M. Mahakhud, P. Mathews, J. Mazzitelli and V. Ravindran, arXiv:1312.7173 [hep-ph].
- [26] D. de Florian, M. Mahakhud, P. Mathews, J. Mazzitelli and V. Ravindran, JHEP **02** (2014) 035 [arXiv:1312.6528 [hep-ph]].
- [27] T. Gehrmann and E. Remiddi, Nucl. Phys. B **640** (2002) 379 [hep-ph/0207020].
- [28] T. Gehrmann, M. Jaquier, E. W. N. Glover and A. Koukoutsakis, JHEP **1202** (2012) 056 [arXiv:1112.3554 [hep-ph]].
- [29] T. Gehrmann, L. Tancredi and E. Weihs, JHEP **1304** (2013) 101 [arXiv:1302.2630].
- [30] S. Catani, Phys. Lett. B427 (1998) 161 [hep-ph/98-2439].
- [31] G. Sterman and M.E. Tejeda-Yeomans, Phys. Lett. B **552** (2003) 48 [hep-ph/0210130].
- [32] P. Mathews, V. Ravindran and K. Sridhar, JHEP **0408** (2004) 048 [hep-ph/0405292].
- [33] E. Remiddi and J.A.M. Vermaseren, Int. J. Mod. Phys. A **15** (2000) 725 [hep-ph/9905237].
- [34] T. Gehrmann and E. Remiddi, Nucl. Phys. **B601** (2001), 248.
- [35] T. Gehrmann and E. Remiddi, Nucl. Phys. **B601** (2001), 287.
- [36] T. Kinoshita, J. Math. Phys. **3** (1962) 650.
- [37] T. D. Lee and M. Nauenberg, Phys. Rev. **133** (1964) B1549.
- [38] S. M. Aybat, L. J. Dixon and G. F. Sterman, Phys. Rev. Lett. **97** (2006) 072001 [hep-ph/0606254].
- [39] S. M. Aybat, L. J. Dixon and G. F. Sterman, Phys. Rev. D **74** (2006) 074004 [hep-ph/0607309].
- [40] V. Ravindran, J. Smith and W. L. van Neerven, Nucl. Phys. B **665** (2003) 325 [hep-ph/0302135].
- [41] V. Ravindran, J. Smith and W. L. van Neerven, Nucl. Phys. B **704** (2005) 332 [hep-ph/0408315].
- [42] T. Becher and M. Neubert, Phys. Rev. Lett. **102** (2009) 162001 [arXiv:0901.0722 [hep-ph]].
- [43] E. Gardi and L. Magnea, JHEP **0903** (2009) 079 [arXiv:0901.1091 [hep-ph]].
- [44] J. A. M. Vermaseren, math-ph/0010025.
- [45] P. Nogueira, Journal of Computational Physics 105 (1993) 279-289.
- [46] F.V. Tkachov, Phys. Lett. **100B** (1981) 65;  
K.G. Chetyrkin and F.V. Tkachov, Nucl. Phys. **B192** (1981) 159.
- [47] T. Gehrmann and E. Remiddi, Nucl. Phys. B **580** (2000) 485 [hep-ph/9912329].
- [48] S. Laporta, Int. J. Mod. Phys. A **15** (2000) 5087 [hep-ph/0102033].
- [49] C. Anastasiou and A. Lazopoulos, JHEP **0407** (2004) 046 [hep-ph/0404258].
- [50] A. V. Smirnov, JHEP **0810** (2008) 107 [arXiv:0807.3243 [hep-ph]].
- [51] C. Studerus, Comput. Phys. Commun. **181** (2010) 1293 [arXiv:0912.2546 [physics.comp-ph]].
- [52] A. von Manteuffel and C. Studerus, arXiv:1201.4330 [hep-ph].
- [53] R. N. Lee, arXiv:1212.2685 [hep-ph].

- [54] R. N. Lee, arXiv:1310.1145 [hep-ph].
- [55] P. Nason, arXiv:0709.2085 [hep-ph].