

Generation of reference dc currents at 1 nA level with the capacitance-charging method

Luca Callegaro, Pier Paolo Capra, Vincenzo D’Elia and Flavio Galliana

Abstract

The capacitance-charging method is a well-established and handy technique for the generation of dc current in the 100 pA range or lower. The method involves a capacitance standard and a sampling voltmeter, highly stable devices easy to calibrate, and it is robust and insensitive to the voltage burden of the instrument being calibrated. We propose here a range extender amplifier, which can be employed as a plug-in component in existing calibration setups, and allows the generation of currents in the 1 nA range. The extender has been employed in the INRIM setup and validated with two comparisons at 100 pA and 1 nA current level. The calibration accuracy achieved on a top-class instrument is 5×10^{-5} at 1 nA.

Index Terms

Metrology; current measurement; measurement techniques; calibration; measurement uncertainty; measurement standards.

I. INTRODUCTION

THE accurate generation of low dc current values is of relevance for the calibration of low dc current meters (picoammeters, femtoammeters) and for research on electron-counting sources based on single-electron tunneling. Methods based on Ohm’s law, where a current I is generated by applying a dc voltage V to a resistor R , becomes increasingly impractical for lower and lower currents. The primary reasons are that very high-valued resistance standards required have high voltage and temperature coefficients, long time constants, are difficult to calibrate; and that the burden voltage of the instrument under calibration is an important source of error.

Recently, several national metrology institutes have developed generators [1]–[7] based on the displacement current in a capacitor, called *capacitance charging* method. A linear voltage ramp $v(t) = St$, having slope S , is applied to a capacitor C (having capacitance C), and a current $I = C \frac{dv(t)}{dt} = SC$ is generated. Appropriate capacitance standards to be employed in the method can be highly stable and can be accurately calibrated; S can be calculated from readings of a sampling voltmeter. The method is not affected by the ammeter burden voltage, which affects $v(t)$ but not its slope S .

The authors are with the Electromagnetism Division of the Istituto Nazionale di Ricerca Metrologica (INRIM), strada delle Cacce 91, 10135 Torino, Italy, e-mail: l.callegaro@inrim.it

Manuscript received May 12, 2017.

The capacitor must be a gas-dielectric or vacuum capacitance standard, since all solid-dielectric capacitors show the phenomenon of dielectric absorption [8] which would severely limit the generator accuracy. Available commercial standard capacitors range from 1 pF to 10 nF¹. However, capacitances above 1 nF are likely to cause oscillations in the input stage of the instrument being calibrated [10] and therefore cannot be employed.

The maximum $S = \frac{2V_{\max}}{T}$ is limited by the maximum voltage V_{\max} available by the ramp generator and the ramp duration T , which should be adequate for measurement settling.

In most published generators [2], [3], [5], [7], $T = 100$ s to 200 s and $V_{\max} = 10$ V, which in turn limits the maximum available current to 100 pA to 200 pA when $S = 0.1 \text{ V s}^{-1}$ and $C = 1$ nF. In one implementation [4] a maximum current of 1 nA has been reached at the expense of raising the current slope to $S = 1 \text{ V s}^{-1}$, hence reducing the available measurement time to 20 s.

In the following, we investigate a simple range extender amplifier, that can be connected to an existing ramp generator. It raises the voltage to the 100 V range, and thus permits the extension of the maximum current range of the capacitance-charging method to 1 nA range. Calibration measurements performed on a top-level instrument are compared with those obtained with Ohm's law method.

II. MEASUREMENT SETUP

The measurement setup is shown in Fig. 1. The range extender amplifier E has a $\times 10$ gain configuration, and is connected to the existing ramp generator RG [3] (having $V_{\max} = 10$ V). The ramp voltage $v(t)$, sampled by the voltmeter V (Agilent 3458A, 10 V or 100 V range), is applied to the gas-dielectric capacitor C and converted to a current I , measured by the meter under calibration M. The timer T provides a clock pulse to all instruments, which are controlled by a personal computer PC. The current is computed from voltage samples with a simple finite-difference model [3].

[Fig. 1 about here.]

The amplifier circuit is shown in Fig. 2.

[Fig. 2 about here.]

III. EXPERIMENTAL

The quantity measured in all experiments is the *calibration factor* Q defined as

$$Q = \frac{I_r - I_{ro}}{I_g} \quad (1)$$

where I_g is the traceable current generated by the source, I_r is the current reading of M when I_g is applied, I_{ro} the current reading of M when zero current is applied.

¹Values lower than 1 pF can be achieved with the Zickner construction [9].

The range extender allows the generation of voltage ramps at $V_{\max} = 100 \text{ V}$ or higher², having properties very similar to the original ramp at $V_{\max} = 10 \text{ V}$ already described in [3]. The noise of E is specified as $20 \text{ nVHz}^{-1/2}$ at audio frequency. Analyses of samples acquired at 1 Hz rate when generating a 100 V fixed output give a noise increase of $40 \mu\text{V}$ rms when E is inserted. Although the input resistance of V is reduced to $10 \text{ M}\Omega$, it does not constitute a significant load for E.

The standard capacitors C employed are General Radio mod. 1404-B, 100 pF, and 1404-C, 1 nF, sealed dry nitrogen capacitors with Invar electrodes. The units are specified for voltages up to 750 V, therefore the V_{\max} increase is well tolerated. The units are calibrated as two terminal-pair standards [11]. The applied voltage during calibration is 15 V for 100 pF and 1.5 V for 1 nF, and the frequency 1 kHz; very different conditions than those of the experiment. A determination of the voltage dependence of these units has not been performed, but it is known that in capacitors of similar construction is below 1×10^{-7} in the 10 V to 100 V rms range [12], [13]. The frequency dependence is more of concern; in gas-dielectric capacitors it has been ascribed to surface effects [14]–[16]. It has been found [15] that in 1404-C models the ‘ac-dc dependence’, i.e. the capacitance deviation between the very low frequency employed in the experiment ($\approx 10 \text{ mHz}$) and 1 kHz (typically below 20×10^{-6} , but with extremes up to 50×10^{-6}) can be predicted from the measured dependence in the audio frequency range (20 Hz – 1 kHz); for the item employed, the prediction gives an ac-dc dependence lower than 10×10^{-6} .

The calibration strategy and the related acquisition, data processing software and uncertainty analysis described in [3], [17] apply.

All experiments involve a top-class dc low current meter (Keithley mod. 6430A Sub-femtoamp remote source-meter) as the instrument under calibration M. The experiment are performed in an electromagnetically shielded room, controlled at $23.0(5) \text{ }^\circ\text{C}$.

An uncertainty budget for the calibration of M with the source including E, at the 1 nA level, is shown in Tab. I. The uncertainty contribution for C is conservative to include the voltage and frequency dependencies previously discussed.

In order to validate the range extender, two different comparisons have been performed, where M is employed as a transfer standard. Since the instrument ranges are decadic ($\pm 100 \text{ pA}$, $\pm 1 \text{ nA}$) the effective nominal current of the comparisons is slightly lower ($\pm 95 \text{ pA}$, $\pm 0.95 \text{ nA}$) than the decadic value to avoid any possible systematic error caused by noise clipping.

[TABLE 1 about here.]

A. Comparison at 100 pA, including and excluding the range extender E

The current source can generate a current of $\pm 100 \text{ pA}$ in two different configurations, that is: by including the range extender E and employing a 100 pF capacitance standard, or by excluding E and employing a 1 nF capacitance

²The op amp employed is rated for about 450 V absolute maximum output.

standard. This allows a substitution comparison, the results of which are shown in Table II; full agreement between the two configurations can be appreciated.

Since the configuration without E was validated in the context of an international intercomparison [17], the comparison is considered a proper validation of the configuration including E.

At the same time, the comparison gives a validation of the assumptions on the voltage and frequency dependencies of the capacitance standards employed.

[TABLE 2 about here.]

B. Comparison at 1 nA, versus Ohm's law method

The comparison at ± 1 nA involves the capacitance-charging source (including E) and a standard calibration setup based on the Ohm's law method. The setup for Ohm's law method is based on a high-valued resistor R and a calibrated dc voltage source V and similar to that described in [18], [19].

In order to make the comparison meaningful and achieve a similar uncertainty for both methods, we chose $R = 10$ G Ω and $V = \pm 10$ V. This required a special calibration of R (standard calibrations are performed at higher voltages) which has been performed with the method described in [20]–[22]. The corresponding uncertainty budget is shown in Table III.

[TABLE 3 about here.]

The uncertainty of the Ohm's law method at ± 1 nA has been evaluated and is given in Table IV. The contribution due to the voltage burden V_B of M appears dominant (Keithley 6430A specifications give $V_B < 1$ mV) for Keithley 6430A), but it can be much lower for other instruments (e.g., Keithley 6517B specifies $V_B < 20$ μ V).

[TABLE 4 about here.]

Results of the comparison at ± 1 nA are given in Table V, showing good agreement between the two methods.

[TABLE 5 about here.]

IV. CONCLUSIONS

The capacitance-charging is a well-established method for accurate generation of low currents. Typical setups have a current limit in the 100 pA range. The range extender amplifier presented here allows an extension of available currents in the nA range; it has been employed as a plug-in component in the INRIM source, and can be adapted to other sources as well. The accuracy of the new setup allows a calibration of top-level meters with a relative uncertainty of 5×10^{-5} ; validation testing has been performed at two different current levels.

A comparison at ± 100 pA, in the two configurations including and excluding the range extender, was made to test the extender on a point already validated through an international intercomparison. The experiment adds confidence in the assumptions on the electrical behavior of the capacitance standards employed.

The comparison at ± 1 nA, versus an implementation of Ohm's law method, showed good agreement with comparable uncertainties, so the methods are mutually validated and can both be employed. It must be however remarked that Ohm's law method required a special resistor calibration, and is very sensitive to the meter burden voltage.

ACKNOWLEDGMENTS

The authors are indebted with their INRIM colleagues Gian Carlo Bosco, for help during measurements, and Fabrizio Manta, who worked on the data acquisition software.

The work has been performed in the framework of Progetto Premiale MIUR-INRIM "Nanotecnologie per la metrologia elettromagnetica".

REFERENCES

- [1] G. D. Willenberg, H. N. Tauscher, and P. Warnecke, "A traceable precision current source for currents between 100 aA and 10 pA," *IEEE Trans. Instr. Meas.*, vol. 52, no. 2, pp. 436–439, Apr. 2003.
- [2] H. van den Brom, P. de la Court, and G. Rietveld, "Accurate subpicoampere current source based on a differentiating capacitor with software-controlled nonlinearity compensation," *IEEE Trans. Instr. Meas.*, vol. 54, no. 2, pp. 554–558, Apr. 2005.
- [3] L. Callegaro, V. D'Elia, and B. Trinchera, "A current source for picoammeter calibration," *IEEE Trans. Instr. Meas.*, vol. 56, no. 4, pp. 1198–1201, Aug. 2007.
- [4] N. E. Fletcher, S. P. Giblin, J. M. Williams, and K. J. Lines, "New capability for generating and measuring small DC currents at NPL," *IEEE Trans. Instr. Meas.*, vol. 56, no. 2, pp. 326–330, Apr. 2007.
- [5] I. Iisakka, K. Kalliomaki, J. Seppala, and A. Manninen, "Subpicoampere current source based on a digital-to-analog converter," in *Conference on Precision Electromagnetic Measurements (CPEM) Digest*, Broomfield, CO, USA, Jun 8-13 2008, pp. 352–353.
- [6] G.-D. Willenberg and H. N. Tauscher, "Novel digital voltage ramp generator for use in precision current sources in the picoampere range," *IEEE Trans. Instr. Meas.*, vol. 58, no. 4, pp. 756–760, Apr. 2009.
- [7] T. Bergsten, K.-E. Rydler, O. Gunnarsson, G. Eklund, and V. Tarasso, "A precision current source using $\Delta - \Sigma$ modulation," *IEEE Trans. Instr. Meas.*, vol. 60, no. 7, pp. 2341–2346, July 2011.
- [8] R. A. Pease, "Understand capacitor soakage to optimize analog systems," *Electronic Design*, pp. 125–129, 1982.
- [9] G. Zickner, "Eine Messbrücke für sehr kleine Kapazitäten," *Elek. Nachr.-Tech.*, vol. 7, pp. 443–448, 1930.
- [10] R. A. Pease, "Whats all this transimpedance amplifier stuff, anyhow?" *Electronic Design*, Jan 2001.
- [11] L. Callegaro, *Electrical impedance: principles, measurement, and applications*, ser. in Sensors. Boca Raton, FL, USA: CRC press: Taylor & Francis, 2013, ch. 2, iSBN: 978-1-43-984910-1.
- [12] J. F. Hersh, "A highly stable reference standard capacitor," *Gen. Radio Experim.*, Aug. 1963.
- [13] J. Q. Shields, "Voltage dependence of precision air capacitors," *J. Res. Natl. Bureau of Std, C: Eng. and Instrum.*, vol. 69C, pp. 265–274, Aug 1965.
- [14] B. D. Inglis, "Frequency dependence of electrode surface effects in parallel-plate capacitors," *IEEE Trans. Instr. Meas.*, vol. 24, pp. 133–150, Jun 1975.
- [15] S. P. Giblin, G. D. Willenberg, and N. E. Fletcher, "Frequency dependence of gas-dielectric capacitors used in sub-nA reference current generators," in *Conference on Precision Electromagnetic Measurements (CPEM) Digest*, Daejeon, Korea, Jun 13-18 2010, pp. 318–319.
- [16] G. Rietveld, N. Zimmerman, and H. van den Brom, "First experimental results of the frequency dependence of a vacuum-gap capacitor between 1 kHz and 0.02 Hz," in *Conference on Precision Electromagnetic Measurements (CPEM) Digest*, Jul. 2012, pp. 708 –709.
- [17] G.-D. Willenberg, "EUROMET.EM-S24: Supplementary comparison of small current sources," *Metrologia*, vol. 50, no. 1A, p. 01002, 2013.
- [18] L. Callegaro, V. D'Elia, P. P. Capra, and A. Sosso, "Techniques for traceable measurements of small currents," *IEEE Trans. Instr. Meas.*, vol. 56, no. 2, pp. 295–299, Apr. 2007.

- [19] F. Galliana and P. P. Capra, "Hamon $10 \times 100 \text{ M}\Omega$ resistor based traceable source for calibration of picoammeters in the range 100 pA – 100 nA," *Measurement*, vol. 43, no. 9, pp. 1277 – 1281, 2010.
- [20] L. C. A. Henderson, "A new technique for the automatic measurement of high value resistors," *J. Phys. E. Sci. Instrum.*, pp. 492–495, 1987.
- [21] D. G. Jarrett, "Automated guarded bridge for calibration of multimegohm standard resistors from 1 $\text{M}\Omega$ to 1 $\text{T}\Omega$," *IEEE Trans. Instr. Meas.*, vol. 46, no. 2, pp. 325–328, 1997.
- [22] F. Galliana, P. P. Capra, and E. Gasparotto, "Evaluation of two alternative methods to calibrate ultra-high value resistors at INRIM," *IEEE Trans. Instrum. Meas.*, vol. 60, no. 3, pp. 965–970, 2011.
- [23] S. Franco, *Design with operational amplifiers and analog integrated circuits*, 3rd ed. McGraw-Hill, 2002.

LIST OF FIGURES

- | | | |
|---|---|---|
| 1 | Block schematics of the measurement setup. RG is the ramp generator, E the range extender amplifier, C the current-generating gas-dielectric capacitor, V the sampling voltmeter, T the timebase generator, M the meter being calibrated, PC the data acquisition computer. | 8 |
| 2 | Range extender amplifier schematics, based on Apex mod. PA88 high-voltage power MOSFET integrated op amp, in a standard $\times 10$ gain configuration. Diodes give input protection; resistor to pin 2 fixes the current limiter. Components between pins 7 and 8 are the datasheet recommended phase compensation network. Further compensation is given by the capacitor in the feedback network [23]. | 9 |

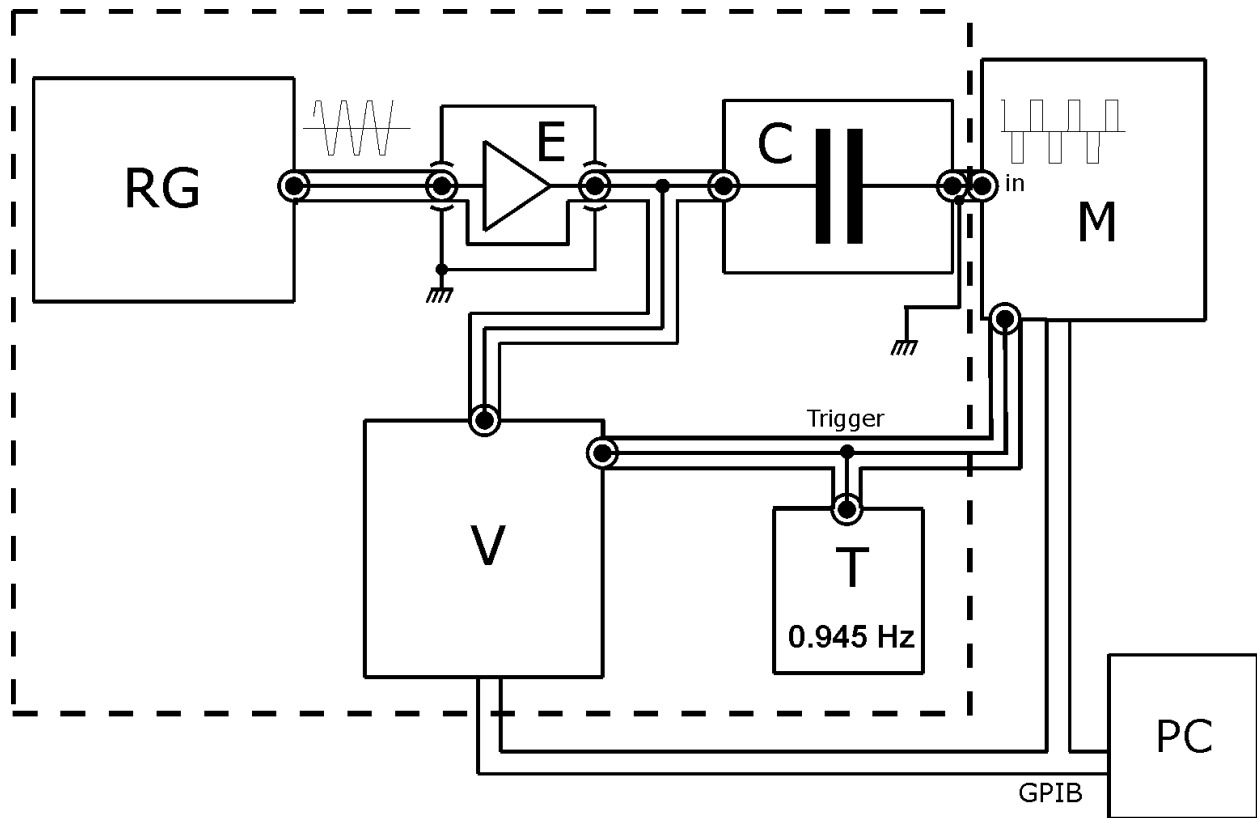

Fig. 1. Block schematics of the measurement setup. RG is the ramp generator, E the range extender amplifier, C the current-generating gas-dielectric capacitor, V the sampling voltmeter, T the timebase generator, M the meter being calibrated, PC the data acquisition computer.

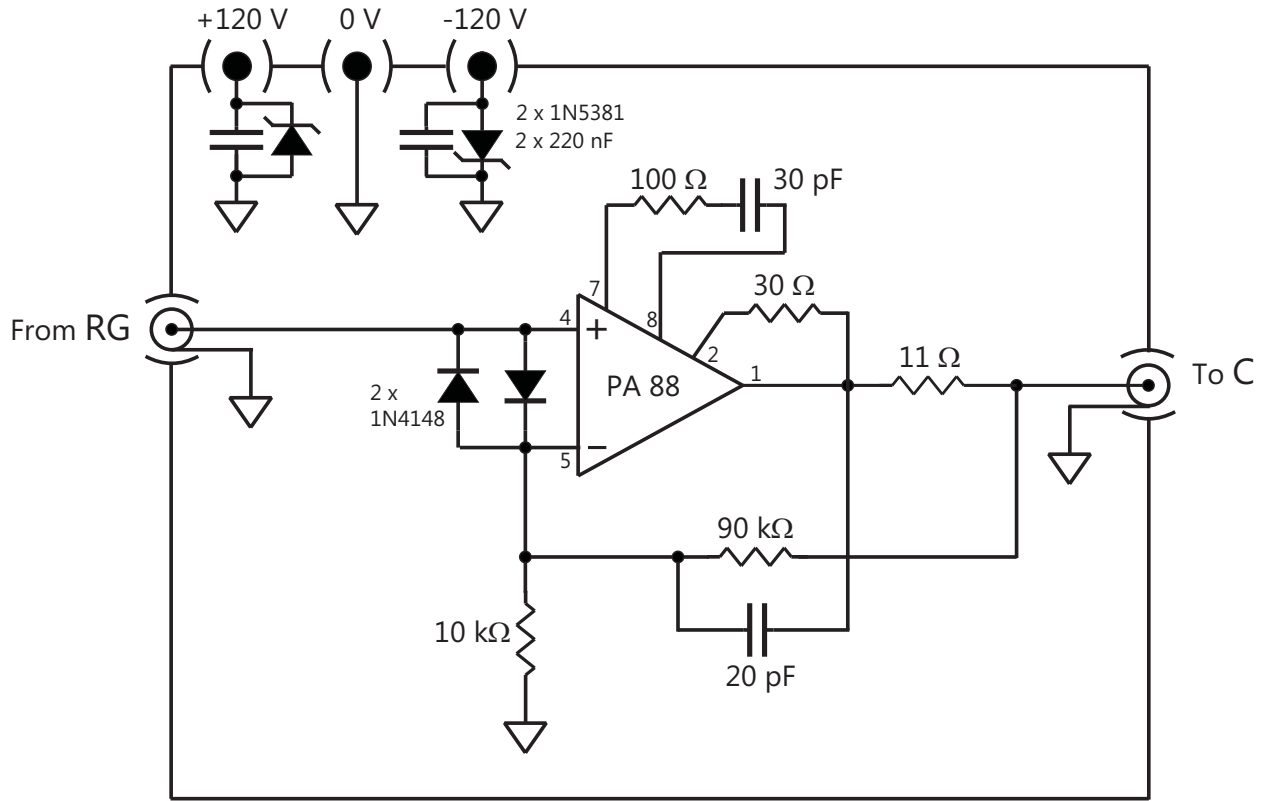

Fig. 2. Range extender amplifier schematics, based on Apex mod. PA88 high-voltage power MOSFET integrated op amp, in a standard $\times 10$ gain configuration. Diodes give input protection; resistor to pin 2 fixes the current limiter. Components between pins 7 and 8 are the datasheet recommended phase compensation network. Further compensation is given by the capacitor in the feedback network [23].

LIST OF TABLES

I	Calibration factor Q at ± 0.95 nA: uncertainty budget	11
II	Comparison at 100 pA	12
III	Calibration of $R = 10$ G Ω at $V = 10$ V: uncertainty budget	13
IV	Ohm's law method, calibration factor Q at ± 0.95 nA: uncertainty budget	14
V	Comparison at 1 nA	15

TABLE I
CALIBRATION FACTOR Q AT ± 0.95 nA: UNCERTAINTY BUDGET

Source	Uncertainty $\mu\text{A A}^{-1}$
M resolution	< 1
C	30
$v(t)$ sampling	6
Timebase	1
Current leakages	10
Reading noise	39
Q	51

TABLE II
COMPARISON AT 100 pA

I	Extender	V_{\max}	C	G
+95 pA	no	9.5 V	1 nF	1.000 390(39)
+95 pA	yes	95 V	100 pF	1.000 372(34)
-95 pA	no	9.5 V	1 nF	1.000 337(37)
-95 pA	yes	95 V	100 pF	1.000 326(34)

TABLE III
CALIBRATION OF $R = 10\text{ G}\Omega$ AT $V = 10\text{ V}$: UNCERTAINTY BUDGET

Source	Uncertainty $\mu\Omega\ \Omega^{-1}$
1 G Ω standard	18
Bridge equilibrium	15
Leakage	3
Bridge ratio	11
Noise	19
$u(R)$	33

TABLE IV
OHM'S LAW METHOD, CALIBRATION FACTOR Q AT ± 0.95 nA: UNCERTAINTY BUDGET

Source	Uncertainty $\mu\text{A A}^{-1}$
R (Tab. III)	33
V	3
M resolution	< 1
M burden voltage	58
Noise	16
$u(Q)$	69

TABLE V
COMPARISON AT 1 nA

I	Method	V or V_{\max}	R or C	Q
+0.95 nA	C charging	95 V	1 nF	1.000 312(50)
+0.95 nA	Ohm's law	+9.5 V	10 G Ω	1.000 320(69)
-0.95 nA	C charging	95 V	1 nF	1.000 265(50)
-0.95 nA	Ohm's law	-9.5 V	10 G Ω	1.000 306(69)