

The Equivalence of the Random Oracle Model and the Ideal Cipher Model, Revisited

Thomas Holenstein* Robin Künzler† Stefano Tessaro‡

May 25, 2022

Abstract

We consider the cryptographic problem of constructing an invertible random permutation from a *public* random function (i.e., which can be accessed by the adversary). This goal is formalized by the notion of *indifferentiability* of Maurer et al. (TCC 2004). This is the natural extension to the public setting of the well-studied problem of building random permutations from random functions, which was first solved by Luby and Rackoff (Siam J. Comput., '88) using the so-called *Feistel* construction.

The most important implication of such a construction is the *equivalence* of the *random oracle model* (Bellare and Rogaway, CCS '93) and the *ideal cipher model*, which is typically used in the analysis of several constructions in symmetric cryptography.

Coron et al. (CRYPTO 2008) gave a rather involved proof that the six-round Feistel construction with independent random round functions is indifferentiable from an invertible random permutation. Also, it is known that fewer than six rounds do not suffice for indifferentiability. The first contribution (and starting point) of our paper is a concrete distinguishing attack which shows that the indifferentiability proof of Coron et al. is *not* correct. In addition, we provide supporting evidence that an indifferentiability proof for the six-round Feistel construction may be very hard to find.

To overcome this gap, our main contribution is a proof that the Feistel construction with eighteen rounds is indifferentiable from an invertible random permutation. The approach of our proof relies on assigning to each of the rounds in the construction a unique and specific role needed in the proof. This avoids many of the problems that appear in the six-round case.

Keywords. Cryptography, random oracle model, ideal cipher model, Feistel construction, indifferentiability.

*ETH Zurich, Department of Computer Science, 8092 Zurich, Switzerland. E-mail: thomas.holenstein@inf.ethz.ch

†ETH Zurich, Department of Computer Science, 8092 Zurich, Switzerland. E-mail: robink@inf.ethz.ch

‡University of California, San Diego, Department of Computer Science & Engineering, La Jolla, CA 92093-0404. E-mail: stessaro@cs.ucsd.edu

Contents

1	Introduction	1
1.1	Random Functions and Permutations: The Feistel Construction	1
1.2	The Random Oracle and Ideal Cipher Models: Indifferentiability	1
1.3	Our Contributions	2
1.4	Sketch of the Previous Problems and the new Proof	3
1.5	Model and Notational Conventions	5
2	The Six-Round Feistel Construction: An Attack	6
2.1	The Simulator of Coron et al.	6
2.2	A problem in the Proof of [CPS08b]	7
2.3	The Attack against the Simulator of [CPS08b]	8
3	Indifferentiability of the Feistel Construction from a Random Permutation	10
3.1	Simulator Definition	10
3.1.1	Informal description	10
3.1.2	The simulator in pseudocode	12
3.2	Proof of Indifferentiability	15
3.2.1	Replacing the permutation with a random function	15
3.2.2	Introducing a Feistel-construction	16
3.2.3	Removing the simulator	17
3.2.4	Indifferentiability	18
3.3	Equivalence of the First and the Second Experiment	18
3.4	Complexity of the Simulator	19
3.5	Equivalence of the Second and the Third Experiment	20
3.5.1	Partial chains	20
3.5.2	Bad events and good executions	21
3.5.3	Bad events are unlikely	23
3.5.4	Properties of good executions	25
3.5.5	Mapping randomness of S_2 to randomness of S_3	29
A	Detailed Definition of the Simulator of Coron et al.	32
B	Detailed Analysis of the Attack against the Simulator of Coron et al.	39
C	A Stronger Attack	46

1 Introduction

1.1 Random Functions and Permutations: The Feistel Construction

Many cryptographic security proofs rely on the assumption that a concrete cryptographic function (e.g. a block cipher or a hash function) behaves as a *random primitive*, i.e., an *ideal* object which answers queries “randomly”. A typical example is a *random function* $\mathbf{F} : \{0, 1\}^m \rightarrow \{0, 1\}^n$, which associates with each m -bit input x a uniformly distributed n -bit value $\mathbf{F}(x)$. We speak of a *random oracle* if the domain consists of all strings of finite length, rather than all m -bit ones. A *random permutation* $\mathbf{P} : \{0, 1\}^n \rightarrow \{0, 1\}^n$ is another example: It behaves as a uniformly-chosen permutation from the set of all permutations on $\{0, 1\}^n$, allowing both *forward queries* $\mathbf{P}(x)$ and *backward queries* $\mathbf{P}^{-1}(y)$.

Many results in cryptography can be recast as finding an explicit construction of a random primitive from another one in a purely information-theoretic setting. For instance, the core of Luby and Rackoff’s seminal result [LR88] on building *pseudorandom permutations* from *pseudorandom functions* (a computational statement) is a construction of a random permutation from random functions via the *r-round Feistel construction* Ψ_r : It implements a permutation taking a $2n$ -bit input $L_0 \| R_0$ (where L_0, R_0 are n -bit values), and the output $L_r \| R_r$ is computed via r rounds mapping L_i, R_i to L_{i+1}, R_{i+1} as

$$L_{i+1} := R_i, \quad R_{i+1} := L_i \oplus \mathbf{F}_{i+1}(R_i),$$

where $\mathbf{F}_1, \dots, \mathbf{F}_r : \{0, 1\}^n \rightarrow \{0, 1\}^n$ are so-called *round functions*. The main statement of [LR88] is that if the round functions are independent random functions, then Ψ_3 is *information-theoretically* indistinguishable from a random permutation which does not allow backward queries, whereas Ψ_4 is indistinguishable from a full-fledged random permutation.

1.2 The Random Oracle and Ideal Cipher Models: Indifferentiability

Random primitives are frequently employed to model an idealized cryptographic function accessible by *all* parties in the scenario at hand, including the adversary. The most prominent example is the *Random Oracle Model* [BR93], where a random oracle models an ideal hash function. Although it is known that no concrete hash function can achieve the functionality of a random oracle [CGH04] (see also [MRH04]), security proofs in the random oracle model provide a common heuristic as to which schemes are expected to remain secure when the random oracle is instantiated with a concrete hash function. In fact, to date, many widely employed practical schemes, such as OEAP [BR94]¹ and FDH [BR96], only enjoy security proofs in the random oracle model.

The *ideal cipher model* is another widespread model in which all parties are granted access to an ideal cipher $\mathbf{E} : \{0, 1\}^\kappa \times \{0, 1\}^n \rightarrow \{0, 1\}^n$, a random primitive such that the restrictions $\mathbf{E}(k, \cdot)$ for $k \in \{0, 1\}^\kappa$ are 2^κ independent random permutations. Application examples of the ideal cipher model range from the analysis of block-cipher based hash function constructions (see, for example [BRS02]) to disproving the existence of generic attacks against constructions such as cascade encryption [BR06, GM09] and to studying generic related-key attacks [BK03].

Equivalence of models and indifferentiability. This paper addresses the fundamental question of determining whether the random oracle model and the ideal cipher model are *equivalent*, where equivalence is to be understood within a simulation-based security framework such as [Can01]: In other words, we aim at answering the following two questions:

¹In fact, standard model instantiations of OAEP for certain classes of trapdoor functions exist [KOS10].

- (1) Can we find a construction \mathbf{C}_1 , which uses an ideal cipher \mathbf{E} , such that $\mathbf{C}_1^{\mathbf{E}}$ is “as good as” a random oracle \mathbf{R} , meaning that any secure cryptographic scheme using \mathbf{R} remains secure when using $\mathbf{C}_1^{\mathbf{E}}$ instead?
- (2) Conversely, is there \mathbf{C}_2 such that $\mathbf{C}_2^{\mathbf{R}}$ is “as good as” an ideal cipher \mathbf{E} ?

Indistinguishability is not sufficient to satisfy the above requirement of being “as good as”, as the adversary can exploit access to the underlying primitive. Instead, the stronger notion of *indifferentiability* due to Maurer et al. [MRH04] is needed: the system $\mathbf{C}_1^{\mathbf{E}}$ is indifferentiable from \mathbf{R} if there exists a *simulator*² \mathbf{S} accessing \mathbf{R} such that $(\mathbf{C}_1^{\mathbf{E}}, \mathbf{E})$ and $(\mathbf{R}, \mathbf{S}^{\mathbf{R}})$ are information-theoretically indistinguishable. This is equivalent to stating that the adversary is able to locally simulate the ideal cipher consistently with \mathbf{R} , given only access to the random oracle and without knowledge of the queries to \mathbf{R} of the honest users. Of course, indifferentiability generalizes to arbitrary primitives: The definition of $\mathbf{C}_2^{\mathbf{R}}$ being indifferentiable from \mathbf{E} is analogous.³

Prior work and applications. Question (1) above is, to date, well understood: Coron et al. [CDMP05], and long series of subsequent work, have presented several constructions of random oracles from ideal ciphers based on hash-function constructions such as the *Merkle-Damgård* construction [Mer89, Dam89] with block-cipher based compression functions. In particular, indifferentiability has become a de-facto standard security requirement for hash function constructions, generally interpreted as the absence of generic attacks against the construction treating the block cipher as a black box.

In a similar vein, answering question (2) could provide new approaches to designing block ciphers from non-invertible primitives. But in contrast to question (1), the problem is far less understood. Dodis and Puniya [DP06] considered constructions in the so-called *honest-but-curious* model, where the adversary only gets to *see* queries made by the construction to the public random function, but is *not* allowed to issue queries of her choice: They showed that $\omega(\log n)$ rounds of the Feistel construction are sufficient to build an ideal cipher.⁴ In the same work, it was first noted that four rounds are insufficient to achieve indifferentiability of the Feistel construction.

Finally, at CRYPTO 2008, Coron et al. [CPS08b] presented a first proof that the six-round Feistel construction Ψ_6 with independent random round functions is indifferentiable from a random permutation,⁵ hence seemingly settling the equivalence of the ideal cipher model and the random oracle model. They also showed that five rounds are insufficient for this task.

1.3 Our Contributions

The surprising starting point of our work is a distinguishing attack, outlined and analyzed in Section 2, which shows that the proof of [CPS08b] is *not* correct: For the simulator given in the proof, our attack distinguishes with overwhelming advantage. Despite hopes, at first, that we could fix the proof of Coron et al. by minor modifications, we were unable to do so. In fact, we provide a stronger attack which appears to succeed against a large class of simulators following the natural

²Usually required to be efficient, i.e., with running time polynomial in the number of queries it processes

³Interestingly, we cannot construct a *non-invertible* random permutation from a random oracle. This follows from a well-known result by Rudich [Rud89].

⁴The notion of honest-but-curious indifferentiability is very subtle, as in general it is not even implied by full indifferentiability.

⁵Note that this implies a construction of an ideal cipher from a random oracle, as we can construct the independent round functions from a random oracle. Moreover, they can be keyed to obtain an independent cipher for each value of the key.

approach of [CPS08b]. Thus, the question of settling the equivalence of the ideal cipher model and of the random oracle model remains open.

In order to overcome this situation, the main contribution of this paper is a proof (given in Section 3) that the eighteen-round Feistel construction Ψ_{18} is indifferentiable from a random permutation. The round number is motivated by the goal of providing a simple to understand proof, rather than by the goal of minimizing the number of rounds. Our proof relies on techniques which are significantly different than the ones used in [CPS08b].

We discuss our results in more detail in the following section.

1.4 Sketch of the Previous Problems and the new Proof

First, we discuss the basic idea of building a random permutation from a random oracle via the r -round Feistel construction Ψ_r . Then we discuss the problems in the previous proofs and finally sketch our new proof.

Simulating by completing chains. The core of the proof is to provide a simulator \mathbf{S} . This simulator should use a given permutation $\mathbf{P} : \{0, 1\}^{2n} \rightarrow \{0, 1\}^{2n}$ and simulate r independent functions $\mathbf{F}_1, \dots, \mathbf{F}_r$ from $\{0, 1\}^n \rightarrow \{0, 1\}^n$. Suppose now that a distinguisher queries round functions as in an evaluation of Ψ_r on input $x \in \{0, 1\}^{2n}$. It is required that the result matches the output of \mathbf{P} on input x .⁶

For this, the simulator somehow needs to recognize such a sequence x_1, \dots, x_r , and set the value of some of the functions $\mathbf{F}_i(x_i)$ such that consistency with \mathbf{P} is ensured. Sequences x_1, \dots, x_r which correspond to a query to the permutation \mathbf{P} are called a *chain*.

The natural idea used by Coron et al. is that one uses some zones in which one detects *partial* chains. An example of a partial chain is a triple (x_1, x_2, x_3) such that $x_3 = x_1 \oplus \mathbf{F}_2(x_2)$, and each of x_1 , x_2 , and x_3 was queried to its corresponding round function \mathbf{F}_i before. On each query to \mathbf{F}_i which the simulator needs to answer, it can check whether such a triple is created.

When such a partial chain is detected (and some additional conditions are met), the simulator *completes* the chain. For this, it defines two values $\mathbf{F}_\ell(x_\ell)$ and $\mathbf{F}_{\ell+1}(x_{\ell+1})$ specifically in order to make the chain match the output of the permutation. In our example, the simulator could first find x_0 , apply the permutation, then apply the Feistel construction backwards until only $\mathbf{F}_4(x_4)$ and $\mathbf{F}_5(x_5)$ are undefined. These two values are then defined such that the partial chain matches up exactly.

At this point, one faces (at least) two possible problems:

- (i) The simulator defines new values at chain completion, and may keep producing new partial chains while it completes chains, hence potentially running forever. Coron et al. solve this problem very elegantly by a smart placement of the zones where they detect chains. Then, they are able to show that the recursion stops after at most $\text{poly}(q)$ steps, where q is the number of queries the distinguisher makes to the permutation. We use their strategy in our proof, even though in the simplified version of [Seu09], as we detect fewer chains.
- (ii) The simulator may try to adapt $\mathbf{F}_\ell(x_\ell)$ to some value in order to match the permutation, even though $\mathbf{F}_\ell(x_\ell)$ has been fixed to a different value before. In this case, the simulator by Coron et al. aborts, and it becomes necessary to show that no distinguisher can make the simulator abort except with negligible probability.

⁶Of course, much more is needed, as the distribution of the output needs to be indistinguishable, but surely, the requirement above is necessary.

Breaking previous simulators. Unfortunately, the proof given in [CPS08b] does not solve (ii) above in a satisfactory manner. In fact, it is possible to find a sequence of queries such that the simulator, with high probability, needs to change the value of a previously fixed $\mathbf{F}_i(x)$. We provide details in Section 2.3. Thus, the simulator given in [CPS08b] can be fully broken. A proof of this fact is contained in Appendix B.

While our proof shows that the simulator does not work, it is clear that it is also possible to simulate the setting. We therefore implemented the simulator from [CPS08b] in Python, and then used our distinguisher on it. The results confirm our analysis. The code is included as an ancillary file in [HKT10], and can be downloaded from there.

In fact, [CPS08b] is *not* the first version of the simulator. The proceedings version of the paper, as well as an earlier version available on the eprint archive [CPS08a] contained a significantly simpler simulator. The simpler simulator, however, suffered from the same problem, except that the attack is also simpler. We assume that the authors were aware of this problem when they modified the simulator, because some of the code seems to specifically rule out some of the attacks we found against the simpler simulator. However, this is speculation: no explanation is given in [CPS08b].

We point out that another, much simpler simulator is given in the PhD thesis of one of the authors [Seu09]. We do not know whether the simulator given in the thesis can be attacked.

Problems with the previous proofs. A natural question is what the problem in the proof is. We explore this question in Section 2.2, but we can give a short explanation here. Consider the example above. When the simulator attempts to define the value of $\mathbf{F}_5(x_5)$, the proof assumes that it can do so, because some time ago, $\mathbf{F}_6(x_6)$ was chosen uniformly at random, and x_5 was set to be $x_5 := x_7 \oplus \mathbf{F}_6(x_6)$. The hope is that this implies that x_5 is a completely new value with high probability, and hence $\mathbf{F}_5(x_5)$ cannot have been defined previously. Unfortunately, between the moment where $\mathbf{F}_6(x_6)$ was chosen uniformly, and the moment where $\mathbf{F}_5(x_5)$ needs to be defined, the simulator may complete a large number of other partial chains. This can destroy the hope completely.⁷ Note that we cannot hope to complete all detected chains immediately, since indeed completing a single chain *can* create a large number of new chains, so that it is not obvious how to solve this problem.

Furthermore, while we do not know whether the simulator in [Seu09] can be attacked, the problems with the proof we describe here are present in [Seu09] as well.

Further problems with previous proofs. There are, in fact, further problems with the previous proofs [CPS08b, Seu09]. All previous proofs reduced the task of proving indifferentiability to the task of upper bounding the abort probability of the given simulator. Yet, it turns out that this reduction is quite delicate as well. In fact, both proofs of [CPS08b] and [Seu09] have several gaps in this part, which we were not able to fill directly.⁸ Thus, we give a completely new proof for this part as well.

Modifications and contributions in this work. We now explain the main ideas we use in order to solve the problems we described. First, since evidence points towards the idea that simulating a 6-round Feistel construction is difficult, we consider the 10-round construction used in [Seu09], which is significantly simpler and much more elegant. Our first idea is that we add buffer rounds

⁷Indeed, our attack exploits such a problem which we found before giving the attack.

⁸In very broad terms, both proofs present a step where an ideal permutation is replaced by the Feistel construction, and values of the round functions are set by the evaluation of the construction: While each of the proofs presents a different approach how this is done, neither of them presents a convincing argument of why this modification does not affect the input-output behavior.

between the zones where chains are detected, and the zones where values are adapted. If we make the buffer big enough, we can identify, in each buffer, a single round i with the following property: in rounds $i - 1$ and $i + 1$, the corresponding values $\mathbf{F}_{i-1}(x_{i-1})$ and $\mathbf{F}_{i+1}(x_{i+1})$ are always defined by setting them to random values, and never by constraints to match the permutation (these rounds are marked green in Figure 2). For the discussion here in the introduction we will call round i and the analogous rounds in the other buffers “protected rounds”. One can show that these protected rounds have the property that at the moment a partial chain is detected, the corresponding values cannot be defined yet.

The hope is that this ensures that (unless an unlikely event happens) the simulator does not define values for protected rounds while completing other chains. This should hold, because the function values in the rounds before and after the protected round are set at random, and so usually the simulator should only run into trouble if some kind of collision happens. However, even though the function values in the rounds before and after are defined at random, once they are defined, it is not a priori clear why no other chain can be set up so it collides with a value in a protected round. For example, it could be that once the *input* value to \mathbf{F}_i in the protected round is known, other chains are set up so that they match this input value. However, it turns out that if we use a queue to enqueue the chains to be completed, this cannot happen. Nevertheless, other problems could arise: for example, it is a priori possible that when values in other chains are *adapted* in order to match the permutation, suddenly collisions with input values in protected rounds appear. This is non-trivial to prevent even if the protected rounds are far away, because it is not easy to understand how chains can be set up in general.

Showing that the values $\mathbf{F}_i(x_i)$ for these protected rounds really *are* undefined when a chain is dequeued (in order to adapt the values so that it matches the permutation) does in fact constitute a large part of our proof.⁹ Furthermore, none of the previous proofs convincingly explains why this property should hold for any round at the moment the chain is *completed*, even if it holds at the moment it is *detected* (in fact, this is exactly the property our attack on [CPS08b] exploits). Once we have given this statement, it is not so hard to show that our simulator does not abort¹⁰, ensuring point (ii) on page 3.

Furthermore, we still have to solve the problem that one needs to show that if it is unlikely that the simulator aborts, then the simulated random function is indistinguishable from an actual random function. For this, we take the following, very explicit approach: we consider the two experiments which we want to show to behave almost the same, and define a map associating randomness in one experiment to randomness in the other experiment. We then study this map. This leads to a more fine-grained understanding and a much more formal treatment of the indistinguishability proof.¹¹

1.5 Model and Notational Conventions

The results throughout this paper are information-theoretic, and consider random experiments where a *distinguisher* \mathbf{D} interacts with some given system \mathbf{S} , outputting a value $\mathbf{D}(\mathbf{S})$. In the context of this paper, such systems consist of the composition $\mathbf{S} = (\mathbf{S}_1, \mathbf{S}_2)$ of two (generally correlated) systems accessible in parallel, where \mathbf{S}_i is either a random primitive (such as a random function \mathbf{F} ,

⁹For later reference: this statement is given in Lemma 3.24 and a large part of Section 3.5.4 is used in order to prove it.

¹⁰Recall that the previous simulator aborted if it needed to overwrite a value when ensuring consistency with the permutation. Our simulator simply overwrites the value in this case, but only because the notation becomes slightly simpler. For the introduction we assume that the simulator aborts instead.

¹¹For reference: this step can be found in Section 3.5.5

a random permutation \mathbf{P} defined above), or a construction $\mathbf{C}^{\mathbf{S}}$ accessing a random primitive \mathbf{S} . In particular, the advantage $\Delta^{\mathbf{D}}(\mathbf{S}, \mathbf{S}')$ of a distinguisher \mathbf{D} in distinguishing two systems \mathbf{S} and \mathbf{S}' is defined as the absolute difference $|\Pr[\mathbf{D}(\mathbf{S}) = 1] - \Pr[\mathbf{D}(\mathbf{S}') = 1]|$.

We dispense to the largest extent with a formal definition of such systems (cf. e.g. the framework of Maurer [Mau02] for a formal treatment). Most systems we consider will be defined formally using pseudocode in a RAM model of computation, following the approach of [BR06, Sho04]. The time complexity of a system/distinguisher is also measured with respect to such a model.

Defining indistinguishability is somewhat subtle, as different definitions [MRH04, CDMP05] are used in the literature. Furthermore, it turns out that our simulator runs in polynomial time only with overwhelming probability (which is a bit weaker than giving a worst-case polynomial bound on its running time). However, it turns out that with both common definitions [MRH04, CDMP05] this is not actually a problem. In fact, we meet the following definition, which implies both of these definitions:

Definition 1.1. For a construction \mathbf{C} accessing independent random functions $\mathbf{F} = (\mathbf{F}_1, \dots, \mathbf{F}_r)$,¹² we say that $\mathbf{C}^{\mathbf{F}}$ is *indifferentiable* from a random permutation \mathbf{P} if there exists a polynomial-time simulator \mathbf{S} such that for all polynomially bounded q , the advantage $\Delta^{\mathbf{D}}((\mathbf{C}^{\mathbf{F}}, \mathbf{F}), (\mathbf{P}, \mathbf{S}^{\mathbf{P}}))$ is negligible for all distinguishers \mathbf{D} issuing totally q queries to the two given systems, where \mathbf{S} is additionally given q as input. \diamond

Finally, we warn the reader that the notation used in Section 2 differs strongly from the one used in Section 3. The reason is that first in Section 2 we aim to stay close to the notation used in [CPS08b] (with some minor modifications which we believe enhance readability). Unfortunately this notation has some obvious problems when as many as 18 rounds are used, which is why we cannot use it in Section 3.

2 The Six-Round Feistel Construction: An Attack

This section presents several problems in the existing proof of Coron et al. [CPS08b]. While we cannot rule out the fact that the six-round Feistel construction is indeed indifferentiable from a random permutation, the contents of this section show that any such proof would be significantly more involved than the one given in [CPS08b].

2.1 The Simulator of Coron et al.

We first provide a high-level description of the simulator \mathbf{S} used in the indistinguishability proof of [CPS08b] for the six-round Feistel construction. This description is sufficient to convey the main ideas underlying our attack and the problems with the existing proof, and a complete description is given in Appendix A. For ease of reference, we use a similar notation to the one of [CPS08b] throughout this section.

Recall that the simulator \mathbf{S} queries \mathbf{P} and \mathbf{P}^{-1} to simulate the round functions $\mathbf{F}_1, \dots, \mathbf{F}_6$ consistently with \mathbf{P} taking the role of the six-round Feistel construction. In particular, for each $i \in \{1, \dots, 6\}$, the simulator stores the values $\mathbf{F}_i(x)$ it has defined up to the current point of execution as a set $\mathcal{H}(\mathbf{F}_i)$ of pairs $(x, \mathbf{F}_i(x))$, called the *history* of \mathbf{F}_i and we denote as $x \in \mathbf{F}_i$ the fact that $\mathbf{F}_i(x)$ is defined. At any point in time, the simulator considers so-called 3-chains, which are triples of values appearing in the histories of three consecutive round functions and which are consistent with the evaluation of the Feistel construction. In the following, when we refer to round

¹²Such a tuple can also be seen as a random primitive.

$i - 1$ or $i + 1$, addition and subtraction are modulo 6, and the elements $\{1, \dots, 6\}$ represent the equivalence classes.

Definition 2.1 (3-chain). A 3-chain is a triple (x, y, z) (where the values are implicitly associated with three consecutive rounds $i - 1$, i , and $i + 1$) which satisfies one of the following conditions with respect to the given histories:

- (i) If $i \in \{2, 3, 4, 5\}$, $x \in \mathbf{F}_{i-1}$, $y \in \mathbf{F}_i$ and $z \in \mathbf{F}_{i+1}$, and $\mathbf{F}_i(y) = x \oplus z$;
- (ii) If $i = 6$, $x \in \mathbf{F}_5$, $y \in \mathbf{F}_6$, $z \in \mathbf{F}_1$, and $\exists x_0 \in \{0, 1\}^n : \mathbf{P}^{-1}(y \parallel \mathbf{F}_6(y) \oplus x) = x_0 \parallel z$;
- (iii) If $i = 1$, $x \in \mathbf{F}_6$, $y \in \mathbf{F}_1$, $z \in \mathbf{F}_2$, and $\exists x_7 \in \{0, 1\}^n : \mathbf{P}(z \oplus \mathbf{F}_1(y) \parallel y) = x \parallel x_7$.

◇

The simulator \mathbf{S} replies with $\mathbf{F}_i(x)$ to a query $x \in \mathbf{F}_i$ for the i -th round function \mathbf{F}_i . Otherwise, if $x \notin \mathbf{F}_i$, the simulator assigns to $\mathbf{F}_i(x)$ a uniform random value, and invokes the procedure CHAINQUERY on input (x, i) . This procedure operates as follows. Let $\mathcal{C}(+, x, i)$ and $\mathcal{C}(-, x, i)$ be the sets of all 3-chains with x in round i as their first value (these are so-called *positive chains*) and as their last value (so-called *negative chains*), respectively. These sets are defined with respect to the point in time where CHAINQUERY(x, i) is called. The procedure iterates over all 3-chains $\mathcal{C}(+, x, i) \cup \mathcal{C}(-, x, i)$, calling the procedure COMPLETECHAIN for each such chain. (More precisely, the simulator only detects a selection of all possible positive and negative 3-chains.)

The procedure COMPLETECHAIN ensures consistency of the defined values with respect to the six-round Feistel construction, and operates as follows on input a positive 3-chain (x, y, z) (a negative chain is processed analogously): It extends it to a 6-tuple (x_1, \dots, x_6) with $x_i = x$, $x_{i+1} = y$ and $x_{i+2} = z$ and the additional property that $\mathbf{F}_i(x_i) = x_{i-1} \oplus x_{i+1}$ for all $i \in \{2, 3, 4, 5\}$ and also that $\mathbf{P}(x_2 \oplus \mathbf{F}_1(x_1) \parallel x_1) = x_6 \parallel \mathbf{F}_6(x_6) \oplus x_5$. This is achieved by first computing x_j for some $j \in \{i - 2, i + 2\}$ and setting the value $\mathbf{F}_j(x_j)$ uniformly at random (if undefined), and then computing the two remaining values x_ℓ and $x_{\ell+1}$, and *adapting* the respective output values $\mathbf{F}_\ell(x_\ell)$ and $\mathbf{F}_{\ell+1}(x_{\ell+1})$ to satisfy the constraint imposed by the permutation \mathbf{P} . Note that it may be that setting these values is not possible (since some $x'_\ell \in \mathbf{F}_\ell$ or some $x'_{\ell+1} \in \mathbf{F}_{\ell+1}$), in which case we say the simulator *aborts*. We point out that in this situation, the simulator is unable to define the remaining chain values consistently with \mathbf{P} . Also, note that the precise choice of how j is chosen depends on the index i , as detailed in Appendix A.

As the completion of these 3-chains defines new entries for the function tables, new 3-chains may appear: Therefore, CHAINQUERY is recursively called on input (x', i') for each value $\mathbf{F}_{i'}(x')$ defined within one of the COMPLETECHAIN calls invoked by CHAINQUERY.

We only briefly point out that some special procedures (called XORQUERY₁, XORQUERY₂, and XORQUERY₃) are called at the beginning of each invocation of CHAINQUERY. Their purpose is to avoid some distinguishing attacks which are possible against the simulator as detailed above. We refer the reader to the Appendix for a complete treatment.

2.2 A problem in the Proof of [CPS08b]

The core of the proof of [CPS08b] consists of a proof that the probability that a distinguisher, while interacting with \mathbf{P} , \mathbf{P}^{-1} , and \mathbf{S} , makes \mathbf{S} abort, is negligible.

The (natural) approach taken in [CPS08b] is, for any execution of CHAINQUERY and under the condition that no abort has occurred so far, to upper bound the probability that \mathbf{S} aborts in one of the recursive calls to CHAINQUERY. To achieve this, the following condition is introduced:

The distribution of $\mathbf{F}_i(x)$ when $\text{CHAINQUERY}(x, i)$ is called is uniform in $\{0, 1\}^n$ given the histories of all round functions, but where the value $\mathbf{F}_i(x)$ is removed from the history, and in the case where the CHAINQUERY invocation results from the completion of a chain, also all other values defined in this completion are removed from the history.

A substantial step is to prove that, in most cases, if the condition holds for a CHAINQUERY invocation, and no abort has occurred so far, then no execution of COMPLETECHAIN aborts, except with negligible probability, and the condition holds for any recursive call to CHAINQUERY . (We note that in some cases it turns out that the condition may not hold, but then a separate proof is given that no abort occurs for such a CHAINQUERY execution, and that the condition holds for all subsequent calls to CHAINQUERY , i.e., such bad invocations do not propagate.)

However, the proof of such statements is very subtle: In particular, between the point in time where the value $\mathbf{F}_i(x)$ is set and the invocation of $\text{CHAINQUERY}(x, i)$, several other CHAINQUERY are potentially made and extend the history. In particular, these additional values in the history may depend on $\mathbf{F}_i(x)$ and may, in fact, fully determine $\mathbf{F}_i(x)$.

It turns out that this possibility is *not* addressed in the proof of [CPS08b] (we also do not see how to extend the proof to cover this), and, as a side note, we just point out that one can build examples which disprove some of the technical claims made in the paper (such as Lemma 10). We refer to [Kün09] for details. We dispense with a description of these arguments, as we give a concrete attack below, which is a much stronger statement, even though this issue is indeed what makes our attack possible.

A Problem in the Proof of [Seu09]. An alternative, and more elegant approach for the 10-round Feistel construction is given by Seurin [Seu09] in his PhD thesis. The core of the proof also consists in proving an upper bound on the abort probability of the simulator.

However, the proof suffers from similar problems as in [CPS08b]. As an example, the proof of Lemma 2.11 in [Seu09] claims that the simulator aborts only with negligible probability in $\text{COMPLETECHAIN}_2(W, R, S, D)$ when adapting $\mathbf{F}_3(X)$, because $X = R \oplus \mathbf{F}_2(W)$, and $\mathbf{F}_2(W)$ is distributed uniformly in $\{0, 1\}^n$. Yet, the statement about $\mathbf{F}_2(W)$ being uniform is questionable, since, similarly to the above case, there are function values defined *after* $\mathbf{F}_2(W) \leftarrow_{\mathbf{R}} \{0, 1\}^n$ occurred, but before $\mathbf{F}_3(X)$ gets adapted. These values might well depend on $\mathbf{F}_2(W)$, and therefore it is not at all clear if $\mathbf{F}_2(W)$ is still distributed uniformly given the values in the history, and how one could prove such a statement.

Orthogonally, conditioning on something different than the complete history at the moment where $\mathbf{F}_2(W)$ is used does also not appear a viable option. This leads us to the conclusion that it is still open if this simulator can be used to prove indistinguishability. However, in contrast to the 6-round case, we have been unable to find a concrete distinguishing attack when this simulator is used.

2.3 The Attack against the Simulator of [CPS08b]

As formalized by the following theorem, we show that there exists a strategy for \mathbf{D} such that \mathbf{S} aborts with overwhelming probability. This immediately implies that \mathbf{S} cannot be used to prove indistinguishability, since using the given strategy, one can distinguish the real setting from the ideal setting (where \mathbf{S} aborts).

Theorem 2.2. *There is a distinguisher \mathbf{D} such that \mathbf{S} aborts with overwhelming probability when \mathbf{D} interacts with \mathbf{P} and \mathbf{S} .*

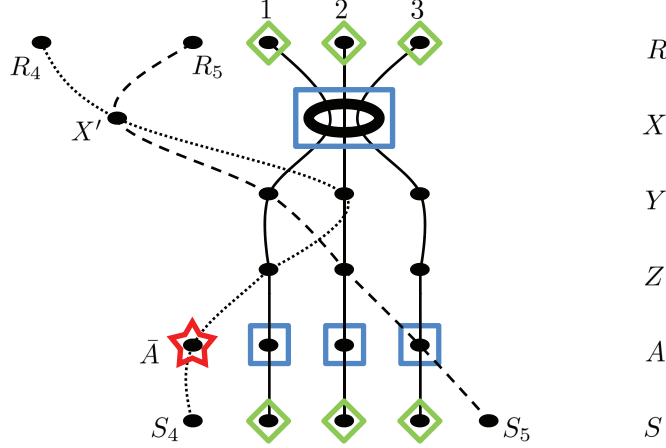

Figure 1: Illustration of the attack provoking the simulator \mathbf{S} to abort.

The main idea of the attack is to ask a very limited number of queries (i.e., 7 queries to the simulator, and three permutations queries) that, when asking the last simulator query, force the simulator to complete five different 3-chains. These are chosen in a way that after completing the first four chains, four values of the completion of the remaining 3-chain are defined *before* the associated permutation query is issued by the simulator. At this point, regardless of the strategy used, it is unlikely that the simulator can set values so that this last chain is completed, and the simulator aborts. Figure 1 illustrates the structure of the (completed) 3-chains.

Outline of the attack and intuition. More concretely, the distinguisher \mathbf{D} chooses n -bit values X , R_2, R_3 , and for $i \in \{2, 3\}$, lets $L_i := \mathbf{F}_1(R_i) \oplus X$, $S_i \| T_i := \mathbf{P}(L_i \| R_i)$, and $A_i := \mathbf{F}_6(S_i) \oplus T_i$. Then, it defines $R_1 := R_2 \oplus A_2 \oplus A_3$, $L_1 := \mathbf{F}_2(X) \oplus R_1$, $S_1 \| T_1 := \mathbf{P}(L_1 \| R_1)$, and $A_1 := \mathbf{F}_6(S_1) \oplus T_1$. It is not hard to verify that (S_i, R_i, X) are all 3-chains for $i = 1, 2, 3$, and when completed to full chains $(R_i, X, Y_i, Z_i, A_i, S_i)$, the values (Y_1, Z_2, A_3) also constitute a 3-chain, since

$$\mathbf{F}_4(Z_2) = A_2 \oplus Y_2 = R_1 \oplus R_2 \oplus A_3 \oplus Y_2 = R_1 \oplus \mathbf{F}_2(X) \oplus A_3 = Y_1 \oplus A_3$$

under the assumption that the first three chains have been completed correctly. Finally, the distinguisher queries $\bar{A} := A_1 \oplus R_1 \oplus R_2$ to \mathbf{F}_5 . Note that (Y_2, Z_1, \bar{A}) also constitutes a 3-chain under the assumptions that the first three chains are completed correctly, since

$$\mathbf{F}_4(Z_1) = Y_1 \oplus A_1 = Y_1 \oplus \bar{A} \oplus R_1 \oplus R_2 = \mathbf{F}_2(X) \oplus \bar{A} \oplus R_2 = \bar{A} \oplus Y_2.$$

Finally, note that

$$Z_1 \oplus \mathbf{F}_3(Y_2) = Z_1 \oplus Z_2 \oplus X = Z_2 \oplus \mathbf{F}_3(Y_1).$$

This means in particular that when completed, the 3-chains (Y_1, Z_2, A_3) and (Y_2, Z_1, \bar{A}) have a common second value, which we denote as X' .

The core idea of the attack is the following: The simulator \mathbf{S} first completes the 3-chains (S_i, R_i, X) for $i = 1, 2, 3$, and only subsequently turns to completing the two remaining 3-chains. Say it completes the 3-chain (Y_2, Z_1, \bar{A}) first: Then, as this chain has a common value with the completion of the 3-chain (Y_1, Z_2, A_3) , in the end the simulator has only two possible values (namely, those at both ends of the completed chain) which are still free to be set to complete the 3-chain

(Y_1, Z_2, A_3) , and this leads to an abort. (In fact, we prove the slightly stronger statement that the simulator fails even if it adopts any other strategy to complete this last chain, once the second-last chain is completed.)

The main difficulty of the full analysis, given in Appendix B, is that the actual simulator makes calls to procedures (called XORQUERY_1 , XORQUERY_2 , and XORQUERY_3) which are intended to prevent (other) attacks, and showing that no such call affects the intuition behind the attack is a rather cumbersome task.

Note that our implementation of the simulator and our attack in Python indeed shows that the simulator aborts (the code can be found as ancilliary file in [HKT10]).

A stronger attack. It is actually possible to come up with a simulator that defines all function values consistently with \mathbf{P} under the attack present in the previous section, and thus the attack falls short of proving that the six-round Feistel construction cannot be indifferntiable from a random permutation. Appendix C presents a stronger distinguishing attack, for which, in fact, we were not able to come up with a simulator which withstands it. We *conjecture* that no simulator within a very large class of simulators is able to withstand this distinguishing attack, but giving such a proof seems to be quite difficult and to require a deeper and more general understanding of the possible dependencies between chains. Nonetheless, we consider this distinguisher to be a useful testbed for any attempt to fix the indifferntiability proof for six rounds.¹³

3 Indifferntiability of the Feistel Construction from a Random Permutation

We prove that the 18-round Feistel construction is indifferntiable from a random permutation.

Theorem 3.1. *The 18-round Feistel construction using 18 independent random functions is indifferntiable from a random permutation.*

The remainder of this section is devoted to the proof of Theorem 3.1. Our task is to provide a simulator \mathbf{S} with access to a random permutation \mathbf{P} such that $(\mathbf{S}^{\mathbf{P}}, \mathbf{P})$ is indistinguishable from $(\mathbf{F}, \Psi^{\mathbf{F}})$, where \mathbf{F} denotes the random functions used in the Feistel construction.

We first define the simulator \mathbf{S} in Section 3.1. Then we transform $(\mathbf{S}^{\mathbf{P}}, \mathbf{P})$ stepwise to $(\mathbf{F}, \Psi^{\mathbf{F}})$. The random functions we consider in this section are always from n bits to n bits, and the random permutation \mathbf{P} is over $2n$ bits.

3.1 Simulator Definition

We first give a somewhat informal, but detailed description of the simulator. We then use pseudocode to specify the simulator in a more formal manner.

3.1.1 Informal description

The simulator provides an interface $\mathbf{S.F}(k, x)$ to query the simulated random function \mathbf{F}_k on input x . For each k , the simulator internally maintains a table that has entries which are pairs (x, y) . They denote pairs of inputs and outputs of $\mathbf{S.F}(k, x)$. We denote these tables by $\mathbf{S.G}_k$ or just G_k when

¹³ We have also implemented this more general attack in Python, and, not surprisingly, its execution also leads to an abort of the simulator \mathbf{S} .

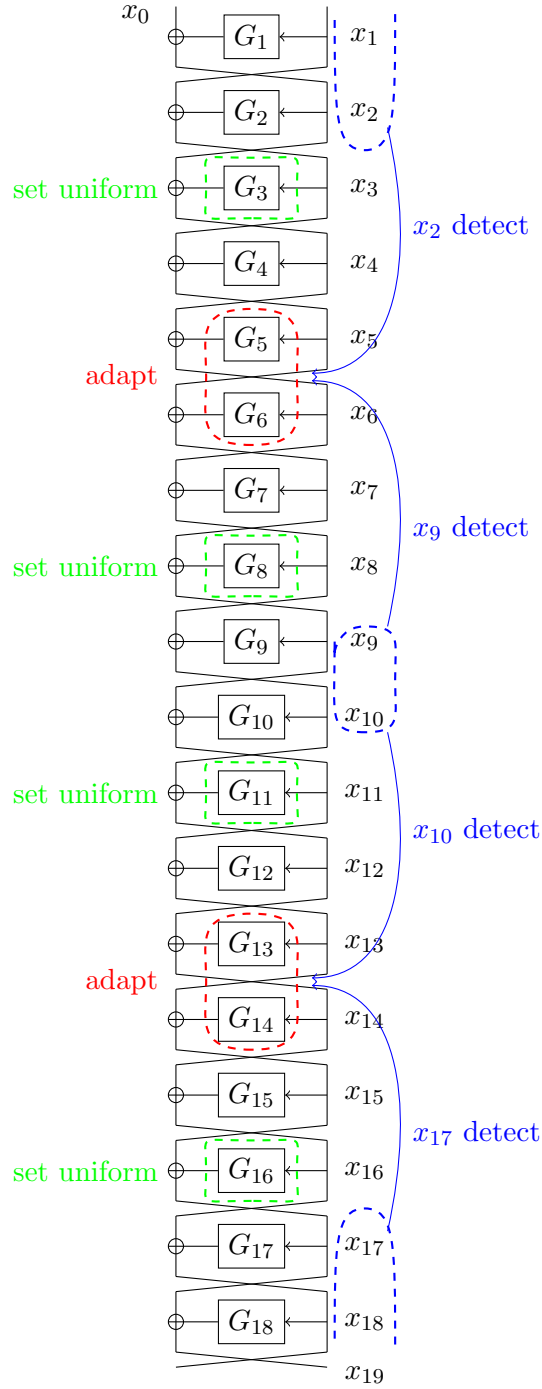

Figure 2: The 18-round Feistel with the zones where our simulator detects chains and adapts them. Whenever a function value $G_2(x_2)$, $G_9(x_9)$, $G_{10}(x_{10})$, or $G_{17}(x_{17})$ is defined, the simulator checks whether the values in the blue dashed zones x_9, x_{10} and x_1, x_2, x_{17}, x_{18} form a partial chain. In case a chain is detected, it is completed; the function values in the red dashed zones are adapted in order to ensure consistency of the chain. We will show in the proof that the function values of G_3 and G_8 are set uniformly at random just before the values in between them are adapted; analogously for G_{11} and G_{16} .

the context is clear. We write $x \in G_k$ to denote that x is a preimage in this table, often identifying G_k with the set of *preimages* stored. When $x \in G_k$, $G_k(x)$ denotes the corresponding image.

On a query $\mathbf{S.F}(k, x)$, the simulator first checks whether $x \in G_k$. If so, it answers with $G_k(x)$. Otherwise the simulator picks a random value y and inserts (x, y) into $G_k(x)$. After this, the simulator takes steps to ensure that in the future it answers consistently with the random permutation \mathbf{P} .

There are two cases in which the simulator performs a specific action for this. First, if $k \in \{2, 17\}$, the simulator considers all newly generated tuples $(x_1, x_2, x_{17}, x_{18}) \in G_1 \times G_2 \times G_{17} \times G_{18}$, and computes $x_0 := x_2 \oplus G_1(x_1)$ and $x_{19} := x_{17} \oplus G_{18}(x_{18})$. It then checks whether $\mathbf{P}(x_0, x_1) = (x_{18}, x_{19})$. Whenever the answer to such a check is positive, the simulator enqueues the detected values in a queue. More precisely, it enqueues a four-tuple $(x_1, x_2, 1, \ell)$. The value 1 ensures that later the simulator knows that the first value x_1 corresponds to G_1 . The value ℓ describes where to adapt values of G_ℓ to ensure consistency with the given permutation. If $k = 2$, then $\ell = 5$ and if $k = 17$ then $\ell = 13$.

The second case is when $k \in \{9, 10\}$. Then, the simulator enqueues all newly generated pairs $(x_9, x_{10}) \in G_9 \times G_{10}$. It enqueues all these pairs into the queue as (x_9, x_{10}, k, ℓ) , where $\ell = 5$ if $k = 9$ and $\ell = 13$ if $k = 10$ (this is illustrated in Figure 2).

After enqueueing this information, the simulator immediately takes the partial chain out of the queue again, and starts completing it. For this, it evaluates the Feistel chain forward and backward (invoking \mathbf{P} or \mathbf{P}^{-1} at one point in order to wrap around), until x_ℓ and $x_{\ell+1}$ are computed, and only the two values $G_\ell(x_\ell)$ and $G_{\ell+1}(x_{\ell+1})$ are possibly undefined. The simulator defines the remaining two values in such a way that consistency is ensured, i.e., $G_\ell(x_\ell) := x_{\ell-1} \oplus x_{\ell+1}$ and $G_{\ell+1}(x_{\ell+1}) := x_\ell \oplus x_{\ell+2}$. If a value for either of these is defined from a previous action of the simulator, the simulator overwrites the value (possibly making earlier chains inconsistent).

During the evaluation of the Feistel chain, the simulator usually defines new values for the tables G . Whenever a value $G_k(x_k)$ for $k \in \{2, 17\}$ is defined, the exact same checks as above are performed on the newly generated tuples $(x_1, x_2, x_{17}, x_{18})$. Whenever a value $G_k(x_k)$ for $k \in \{9, 10\}$ is defined, the simulator similarly enqueues all new pairs (x_9, x_{10}) .

When the simulator has finished completing a chain, it checks whether the queue is now empty. While it is not empty, it keeps dequeuing entries and completing chains, otherwise, it returns the answer to the initial query to the caller.

In order to make sure the simulator does not complete the same chains twice, the simulator additionally keeps a set `CompletedChains` that contains all triples (x_k, x_{k+1}, k) which have been completed previously. Whenever the simulator dequeues a chain, it checks whether it is already in this set before completing it.

3.1.2 The simulator in pseudocode

We now provide pseudocode to describe the simulator as explained above in full detail. Later, during the analysis, we will consider a slightly different simulator \mathbf{T} . For this, we replace whole lines; the replacements are put into boxes next to these lines. The reader can ignore these replacements at the moment.

First, the simulator internally uses a queue and some hashtables to store the function values, and a set `CompletedChains` to remember the chains that have been completed already.

1 **System S:**

System T(f):

2 **Variables:**

3 Queue Q

4 Hashtable G_1, \dots, G_{18}
5 Set CompletedChains := \emptyset

The procedure $F(i, x)$ provides the interface to a distinguisher. It first calls the corresponding internal procedure F^{INNER} , which defines the value and fills the queue if necessary. Then, the procedure $F(i, x)$ completes the chains in the queue that were not completed previously, until the queue is empty.

```

6  public procedure F( $i, x$ )
7       $F^{\text{INNER}}(i, x)$ 
8      while  $\neg Q.\text{EMPTY}()$  do
9           $(x_k, x_{k+1}, k, \ell) := Q.\text{DEQUEUE}()$ 
10         if  $(x_k, x_{k+1}, k) \notin \text{CompletedChains}$  then // ignore previously completed chains
11              $(x_{\ell-3}, x_{\ell-2}) := \text{EVALUATEFORWARD}(x_k, x_{k+1}, k, \ell - 3)$ 
12              $(x_{\ell+3}, x_{\ell+4}) := \text{EVALUATEBACKWARD}(x_k, x_{k+1}, k, \ell + 3)$ 
13              $\text{ADAPT}(x_{\ell-3}, x_{\ell-2}, x_{\ell+3}, x_{\ell+4}, \ell)$ 
14              $(x_1, x_2) := \text{EVALUATEBACKWARD}(x_k, x_{k+1}, k, 1)$ 
15              $(x_9, x_{10}) := \text{EVALUATEFORWARD}(x_1, x_2, 1, 9)$ 
16             CompletedChains := CompletedChains  $\cup \{(x_1, x_2, 1), (x_9, x_{10}, 9)\}$ 
17         return  $G_i(x)$ 

```

The procedure ADAPT adapts the values. It first sets the values marked green in Figure 2 uniformly at random, and also the next ones. It then adapts the values of $G_\ell(x_\ell)$ and $G_{\ell+1}(x_{\ell+1})$ such that the chain matches the permutation.

It would be possible to simplify the code by removing lines 19 to 30 below, and changing the parameters in lines 11 and 12 above. The current notation simplifies notation in the proof.

```

18 private procedure ADAPT( $x_{\ell-3}, x_{\ell-2}, x_{\ell+3}, x_{\ell+4}, \ell$ )
19     if  $x_{\ell-2} \notin G_{\ell-2}$  then
20          $G_{\ell-2}(x_{\ell-2}) \leftarrow_R \{0, 1\}^n$       $G_{\ell-2}(x_{\ell-2}) := f(\ell - 2, x_{\ell-2})$ 
21      $x_{\ell-1} := x_{\ell-3} \oplus G_{\ell-2}(x_{\ell-2})$ 
22     if  $x_{\ell+3} \notin G_{\ell+3}$  then
23          $G_{\ell+3}(x_{\ell+3}) \leftarrow_R \{0, 1\}^n$       $G_{\ell+3}(x_{\ell+3}) := f(\ell + 3, x_{\ell+3})$ 
24      $x_{\ell+2} := x_{\ell+4} \oplus G_{\ell+3}(x_{\ell+3})$ 
25     if  $x_{\ell-1} \notin G_{\ell-1}$  then
26          $G_{\ell-1}(x_{\ell-1}) \leftarrow_R \{0, 1\}^n$       $G_{\ell-1}(x_{\ell-1}) := f(\ell - 1, x_{\ell-1})$ 
27      $x_\ell := x_{\ell-2} \oplus G_{\ell-1}(x_{\ell-1})$ 
28     if  $x_{\ell+2} \notin G_{\ell+2}$  then
29          $G_{\ell+2}(x_{\ell+2}) \leftarrow_R \{0, 1\}^n$       $G_{\ell+2}(x_{\ell+2}) := f(\ell + 2, x_{\ell+2})$ 
30      $x_{\ell+1} := x_{\ell+3} \oplus G_{\ell+2}(x_{\ell+2})$ 
31     FORCEVAL( $x_\ell, x_{\ell+1} \oplus x_{\ell-1}, \ell$ )
32     FORCEVAL( $x_{\ell+1}, x_\ell \oplus x_{\ell+2}, \ell + 1$ )
33
34 private procedure FORCEVAL( $x, y, \ell$ )
35      $G_\ell(x) := y$ 

```

The procedure F^{INNER} provides the internal interface for evaluations of the simulated function. It only fills the queue, but does not empty it.

```

36 private procedure  $F^{\text{INNER}}(i, x):$ 

```

```

37   if  $x \notin G_i$  then
38        $G_i(x) \leftarrow_R \{0, 1\}^n$             $G_i(x_i) := f(i, x_i)$ 
39       if  $i \in \{2, 9, 10, 17\}$  then
40           ENQUEUENEWCHAINS( $i, x$ )
41   return  $G_i(x)$ 

```

The procedure ENQUEUENEWCHAINS detects newly created chains and enqueues them. Sometimes, chains may be detected which have been completed before, but they are ignored when they are dequeued.

```

42 private procedure ENQUEUENEWCHAINS( $i, x$ ):
43   if  $i = 2$  then
44       forall  $(x_1, x_2, x_{17}, x_{18}) \in G_1 \times \{x\} \times G_{17} \times G_{18}$  do
45           if CHECK( $x_2 \oplus G_1(x_1), x_1, x_{18}, x_{17} \oplus G_{18}(x_{18})$ ) then
46                $Q.$ ENQUEUE( $x_1, x_2, 1, 5$ )
47   else if  $i = 17$  then
48       forall  $(x_1, x_2, x_{17}, x_{18}) \in G_1 \times G_2 \times \{x\} \times G_{18}$  do
49           if CHECK( $x_2 \oplus G_1(x_1), x_1, x_{18}, x_{17} \oplus G_{18}(x_{18})$ ) then
50                $Q.$ ENQUEUE( $x_1, x_2, 1, 13$ )
51   else if  $i = 9$  then
52       forall  $(x_9, x_{10}) \in \{x\} \times G_{10}$  do
53            $Q.$ ENQUEUE( $x_9, x_{10}, 9, 5$ )
54   else if  $i = 10$  then
55       forall  $(x_9, x_{10}) \in G_9 \times \{x\}$  do
56            $Q.$ ENQUEUE( $x_9, x_{10}, 9, 13$ )
57
58 private procedure CHECK( $x_0, x_1, x_{18}, x_{19}$ )
59   return  $\mathbf{P}(x_0, x_1) = (x_{18}, x_{19})$             $\mathbf{return} \mathbf{R}.$ CHECK( $x_0, x_1, x_{18}, x_{19}$ )

```

The helper procedures EVALUATEFORWARD and EVALUATEBACKWARD take indices k and ℓ and a pair (x_k, x_{k+1}) of input values for G_k and G_{k+1} , and either evaluate forward or backward in the Feistel to obtain the pair $(x_\ell, x_{\ell+1})$ of input values for G_ℓ and $G_{\ell+1}$.

```

60 private procedure EVALUATEFORWARD( $x_k, x_{k+1}, k, \ell$ ):
61   while  $k \neq \ell$  do
62       if  $k = 18$  then
63            $(x_0, x_1) := \mathbf{P}^{-1}(x_{18}, x_{19})$             $(x_0, x_1) := \mathbf{R}.$  $\mathbf{P}^{-1}(x_{18}, x_{19})$ 
64            $k := 0$ 
65       else
66            $x_{k+2} := x_k \oplus \mathbf{F}^{\text{INNER}}(k + 1, x_{k+1})$ 
67            $k := k + 1$ 
68   return  $(x_\ell, x_{\ell+1})$ 
69
70 private procedure EVALUATEBACKWARD( $x_k, x_{k+1}, k, \ell$ ):
71   while  $k \neq \ell$  do
72       if  $k = 0$  then
73            $(x_{18}, x_{19}) := \mathbf{P}(x_0, x_1)$             $(x_{18}, x_{19}) := \mathbf{R}.$  $\mathbf{P}(x_0, x_1)$ 
74            $k := 18$ 

```



```

75     else
76          $x_{k-1} := x_{k+1} \oplus F^{\text{INNER}}(k, x_k)$ 
77          $k := k - 1$ 
78     return  $(x_\ell, x_{\ell+1})$ 

```

3.2 Proof of Indifferentiability

In this section, we provide the indifferentiability analysis. The overall plan is that we first fix a deterministic distinguisher \mathbf{D} , and suppose that it makes at most q queries. We then show that the probability that \mathbf{D} outputs 1 when interacting with $(\mathbf{P}, \mathbf{S}^{\mathbf{P}})$ differs by at most $\frac{\text{poly}(q)}{2^n}$ from the probability it outputs 1 when interacting with $(\Psi^{\mathbf{F}}, \mathbf{F})$, where Ψ is an 18-round Feistel construction, and \mathbf{F} is a collection of 18 uniform random functions.

We denote the scenario where \mathbf{D} interacts with $(\mathbf{P}, \mathbf{S}^{\mathbf{P}})$ by \mathbf{S}_1 , and the scenario where \mathbf{D} interacts with $(\Psi^{\mathbf{F}}, \mathbf{F})$ by \mathbf{S}_4 . The scenarios \mathbf{S}_2 and \mathbf{S}_3 will be intermediate scenarios.

3.2.1 Replacing the permutation with a random function

Scenario $\mathbf{S}_2(f, p)$ is similar to \mathbf{S}_1 . However, instead of the simulator \mathbf{S} we use a simulator $\mathbf{T}(f)$, and instead of a random permutation \mathbf{P} we use a two-sided random function $\mathbf{R}(p)$. The differences between these systems are as follows:

Explicit randomness: We make the randomness used by the the simulator explicit. Whenever \mathbf{S} sets $G_i(x_i)$ to a random value, $\mathbf{T}(f)$ takes it from $f(i, x_i)$ instead, where f is a table which contains an independent uniform random bitstring of length n for each $i \in \{1, 2, \dots, 18\}$ and $x_i \in \{0, 1\}^n$. This modification does not change the distribution of the simulation, because it is clear that the simulator considers each entry of f at most once.

As depicted in the pseudocode below, the randomness of the two-sided random function $\mathbf{R}(p)$ is also explicit: it is taken from $p(\uparrow, x_0, x_1)$ or $p(\downarrow, x_{18}, x_{19})$, a table in which each entry is an independent uniform random bitstring of length $2n$.

Two-sided random function: We replace the random permutation \mathbf{P} by a two-sided random function $\mathbf{R}(p)$ (see below for pseudocode). This function keeps a hashtable P which contains elements (\downarrow, x_0, x_1) and $(\uparrow, x_{18}, x_{19})$. Whenever the procedure $\mathbf{R}.P(x_0, x_1)$ is queried, \mathbf{R} checks whether $(\downarrow, x_0, x_1) \in P$, and if so, answers accordingly. Otherwise, an independent uniform random output (x_{18}, x_{19}) is picked (by considering p), and (\downarrow, x_0, x_1) as well as $(\uparrow, x_{18}, x_{19})$ are added to P , mapping to each other.

CHECK procedure: Additionally, the two-sided random function \mathbf{R} has a procedure $\text{CHECK}(x_0, x_1, x_{18}, x_{19})$. It checks whether P maps (\downarrow, x_0, x_1) to (x_{18}, x_{19}) , and if so, returns true. If not, it checks whether P maps $(\uparrow, x_{18}, x_{19})$ to (x_0, x_1) , and if so, returns true. Otherwise, it returns false. The simulator $\mathbf{T}(f)$ also differs from \mathbf{S} in that $\mathbf{T}(f).\text{CHECK}$ simply calls $\mathbf{R}.\text{CHECK}$.

Pseudocode for $\mathbf{T}(f)$ can be obtained by using the boxed contents on the right hand side in the pseudocode of \mathbf{S} instead of the corresponding line. For the two-sided random function \mathbf{R} , pseudocode looks as follows:

```

1 System Two-Sided Random Function  $\mathbf{R}(p)$ :
2 Variables:
3     Hashtable  $P$ 
4

```

```

5 public procedure P( $x_0, x_1$ )
6   if ( $\downarrow, x_0, x_1 \notin P$ ) then
7     ( $x_{18}, x_{19}$ ) :=  $p(\downarrow, x_0, x_1)$ 
8      $P(\downarrow, x_0, x_1)$  := ( $x_{18}, x_{19}$ )
9      $P(\uparrow, x_{18}, x_{19})$  := ( $x_0, x_1$ ) // (May overwrite an entry)
10    return  $P(\downarrow, x_0, x_1)$ 
11
12 public procedure P-1( $x_{18}, x_{19}$ )
13   if ( $\uparrow, x_{18}, x_{19} \notin P$ ) then
14     ( $x_0, x_1$ ) :=  $p(\uparrow, x_{18}, x_{19})$ 
15      $P(\downarrow, x_0, x_1)$  := ( $x_{18}, x_{19}$ ) // (May overwrite an entry)
16      $P(\uparrow, x_{18}, x_{19})$  := ( $x_0, x_1$ )
17    return  $P(\uparrow, x_{18}, x_{19})$ 
18
19 public procedure CHECK( $x_0, x_1, x_{18}, x_{19}$ )
20   if ( $\downarrow, x_0, x_1 \in P$ ) then return  $P(\downarrow, x_0, x_1) = (x_{18}, x_{19})$ 
21   if ( $\uparrow, x_{18}, x_{19} \in P$ ) then return  $P(\uparrow, x_{18}, x_{19}) = (x_0, x_1)$ 
22   return false

```

We claim that for uniformly chosen (f, p) , the probability that \mathbf{D} outputs 1 in scenario $\mathbf{S}_2(f, p)$ differs only by $\frac{\text{poly}(q)}{2^n}$ from the probability it outputs 1 in \mathbf{S}_1 . For this, we first note that clearly the simulator can take the randomness from f without any change. Secondly, instead of the procedure CHECK in the simulator \mathbf{S} , we can imagine that the random permutation \mathbf{P} has a procedure $\mathbf{P.CHECK}$ which is implemented exactly as in line 58 of \mathbf{S} , and $\mathbf{S.CHECK}$ simply calls $\mathbf{P.CHECK}$. The following lemma states that such a system \mathbf{P} is indistinguishable from \mathbf{R} as above, which then implies the claim. We prove the lemma in Section 3.3; the proof is neither surprising nor particularly difficult.

Lemma 3.2. *Consider a random permutation over $2n$ bits, to which we add the procedure CHECK as in line 58 of the simulator \mathbf{S} . Then, a distinguisher which issues at most q queries to either the random permutation or to the two-sided random function \mathbf{R} has advantage at most $\frac{10q^2}{2^{2n}}$ in distinguishing the two systems.*

Additionally, we will need that in \mathbf{S}_2 the number of queries made by the simulator is $\text{poly}(q)$. This is given in the following lemma, which we prove in Section 3.4.

Lemma 3.3. *In \mathbf{S}_2 , at any point in the execution we have $|G_i| \leq 6q^2$ for all i . Furthermore, there are at most $6q^2$ queries to both $\mathbf{R.P}$, and $\mathbf{R.P}^{-1}$, and at most $1296q^8$ queries to $\mathbf{R.CHECK}$.*

In order to prove Lemma 3.3, we can follow the elegant idea from [CPS08b]. Thus, while we give the proof for completeness, it should not be considered a contribution of this paper. It is in fact very similar to the corresponding proof in [Seu09].

3.2.2 Introducing a Feistel-construction

In $\mathbf{S}_3(h)$, we replace the above two-sided random function $\mathbf{R}(p)$ by a Feistel construction $\Psi(h)$. For this, we use the following system:

```

1 System  $\Psi(h)$ :
2
3 Variables:

```

```

4     Hashtable  $H_1, \dots, H_{18}$ 
5     Hashtable  $P$ 
6
7     private procedure  $F(i, x_i)$ :
8         if  $x_i \notin H_i$  then
9              $H_i(x_i) := h(i, x_i)$ 
10        return  $H_i(x_i)$ 
11
12    public procedure  $P(x_0, x_1)$ 
13        for  $i := 2$  to  $19$  do
14             $x_i := x_{i-2} \oplus F(i-1, x_{i-1})$ 
15             $P(\downarrow, x_0, x_1) := (x_{18}, x_{19})$ 
16             $P(\uparrow, x_{18}, x_{19}) := (x_0, x_1)$ 
17        return  $(x_{18}, x_{19})$ 
18
19    public procedure  $P^{-1}(x_{18}, x_{19})$ 
20        for  $i := 17$  to  $0$  step  $-1$  do
21             $x_i := x_{i+2} \oplus F(i+1, x_{i+1})$ 
22             $P(\downarrow, x_0, x_1) := (x_{18}, x_{19})$ 
23             $P(\uparrow, x_{18}, x_{19}) := (x_0, x_1)$ 
24        return  $(x_0, x_1)$ 
25
26    public procedure  $CHECK(x_0, x_1, x_{18}, x_{19})$ 
27        if  $(\downarrow, x_0, x_1) \in P$  then return  $P(\downarrow, x_0, x_1) = (x_{18}, x_{19})$ 
28        if  $(\uparrow, x_{18}, x_{19}) \in P$  then return  $P(\uparrow, x_{18}, x_{19}) = (x_0, x_1)$ 
29        return false

```

We define $S_3(h)$ to be the system where the distinguisher interacts with $(\Psi(h), \mathbf{T}(h)^{\Psi(h)})$. Note that the randomness used by Ψ and \mathbf{T} is the same, and we call it h . We show the following lemma in Section 3.5. We believe that our proof is interesting, because it directly maps pairs (f, p) to elements $h = \tau(f, p)$ such that $S_2(f, p)$ and $S_3(h)$ behave the same for most pairs (f, p) , and the distribution induced by τ is close to uniform. The proof of this lemma is the main contribution of this paper. It is completely different from the corresponding step in [CPS08b].

Lemma 3.4. *The probability that a fixed distinguisher answers 1 in $S_2(f, p)$ for uniform random (f, p) differs at most by $\text{poly}(q)/2^n$ from the probability that it answers 1 in $S_3(h)$ for uniform random h .*

3.2.3 Removing the simulator

In S_3 , the distinguisher accesses the random functions through the simulator. We want to show that the distinguisher can instead access the random functions directly.

Lemma 3.5. *Suppose that in $S_3(h)$, the simulator $\mathbf{T}(h)$ eventually answers a query $F(i, x)$. Then, it is answered with $h(i, x)$.*

Proof. The simulator $\mathbf{T}(h)$ either sets $G_i(x) := h(i, x)$ or $G_i(x_i) := x_{i-1} \oplus x_{i+1}$ in a call to adapt. For pairs (i, x) which are set by the first call the lemma is clear. Otherwise, consider the ADAPT call: just before the call, the Feistel construction was evaluated either forward or backward in a call

to $\Psi.P(x_0, x_1)$ or $\Psi.P^{-1}(x_{18}, x_{19})$. Since Ψ evaluates P and P^{-1} with calls to h , the value $G_i(x_i)$ must be $h(i, x)$ as well. \square

3.2.4 Indifferentiability

We can now prove Theorem 3.1, which we restate here for convenience.

Theorem 3.1. *The 18-round Feistel construction using 18 independent random functions is indifferentiable from a random permutation.*

Proof. Fix a distinguisher \mathbf{D} which makes at most q queries. We want to show that \mathbf{D} fails to distinguish $\mathbf{S}_1 = (\mathbf{P}, \mathbf{S}^{\mathbf{P}})$ from $\mathbf{S}_4 = (\Psi^{\mathbf{F}}, \mathbf{F})$, and furthermore, that the simulator runs in polynomial time.

Consider the system \mathbf{S}_1 , where the distinguisher interacts with $(\mathbf{P}, \mathbf{S}^{\mathbf{P}})$. If we replace \mathbf{P} with the two-sided random function \mathbf{R} as described above and the simulator \mathbf{S} by $\mathbf{T}(f)$, then we obtain \mathbf{S}_2 . According to Lemma 3.3 the number of queries the simulator makes in \mathbf{S}_2 to \mathbf{R} is at most $\text{poly}(q)$. Since Lemma 3.2 gives that the permutation is indistinguishable from a two-sided random function, we get that the probability that \mathbf{D} outputs 1 differs by at most $\text{poly}(q)/2^n$ in \mathbf{S}_1 and \mathbf{S}_2 . Furthermore, also by Lemma 3.2, with probability $1 - \frac{\text{poly}(q)}{2^n}$, the first $\text{poly}(q)$ calls are equivalent in \mathbf{S}_1 and \mathbf{S}_2 , so that the simulator is efficient in \mathbf{S}_1 with high probability.

Now, the probability that \mathbf{D} outputs 1 does not differ by more than $\text{poly}(q)/2^n$ in \mathbf{S}_2 and \mathbf{S}_3 , by Lemma 3.4. Finally, since this implies that with probability $1 - \text{poly}(q)/2^n$ the distinguisher must give an answer in \mathbf{S}_3 , we can also use Lemma 3.5 and get that the probability that the distinguisher answers 1 differs in \mathbf{S}_3 and \mathbf{S}_4 by at most $\frac{\text{poly}(q)}{2^n}$. \square

3.3 Equivalence of the First and the Second Experiment

We now show that \mathbf{S}_1 and \mathbf{S}_2 behave the same way, more concretely, that our two-sided random function \mathbf{R} behaves as a uniform random permutation \mathbf{P} .

Lemma 3.2. *Consider a random permutation over $2n$ bits, to which we add the procedure CHECK as in line 58 of the simulator \mathbf{S} . Then, a distinguisher which issues at most q queries to either the random permutation or to the two-sided random function \mathbf{R} has advantage at most $\frac{10q^2}{2^{2n}}$ in distinguishing the two systems.*

Proof. First, assume that the procedures $\mathbf{P}.P$ and $\mathbf{P}.P^{-1}$ of the random permutation are implemented as in the two-sided random-function \mathbf{R} above, but the randomness p provided is chosen from a permutation (i.e., $p(\downarrow, x_0, x_1) = (x_{18}, x_{19})$ if and only if $p(\uparrow, x_{18}, x_{19}) = (x_0, x_1)$). The CHECK procedure of the random permutation is implemented as in the simulator, i.e.:

```

1 public procedure  $\mathbf{P}.$ CHECK( $x_0, x_1, x_{18}, x_{19}$ )
2   return  $p(\downarrow, x_0, x_1) = (x_{18}, x_{19})$ 

```

Now, replace the procedure CHECK in \mathbf{P} with the following code (which does not change anything):

```

1 public procedure  $\mathbf{P}.$ CHECK'( $x_0, x_1, x_{18}, x_{19}$ )
2   if  $(\downarrow, x_0, x_1) \in P$  then return  $P(\downarrow, x_0, x_1) = (x_{18}, x_{19})$ 
3   if  $(\uparrow, x_{18}, x_{19}) \in P$  then return  $P(\uparrow, x_{18}, x_{19}) = (x_0, x_1)$ 
4   return  $p(\downarrow, x_0, x_1) = (x_{18}, x_{19}) \vee p(\uparrow, x_{18}, x_{19}) = (x_0, x_1)$ 

```

Now, replace the table p of a uniform random permutation with the table of a uniform random function, and let the resulting system be \mathbf{R}' . If we make q' queries to p , then this behaves as the

previous table with probability $1 - \frac{(q')^2}{2^{2n}}$, which follows by the standard indistinguishability of a random permutation and a random function. Because $q' \leq 2q$, we see that until now we have at most advantage $\frac{4q^2}{2^{2n}}$ in distinguishing the two systems.

Let \mathbf{R} be the two-sided random function, and consider the system \mathbf{R}' as defined above (\mathbf{R}' is the same as \mathbf{R} , except that `CHECK` is replaced by `CHECK'`). We define a bad event `ContradictCheck` for \mathbf{R} and a bad event `BadCheck` for \mathbf{R}' . We then show that conditioned on neither of these bad events occurring, the two systems behave identically. Then, we show that the events cannot be provoked, which implies the result.

The event `ContradictCheck` occurs in \mathbf{R} if there exists a tuple $(x_0, x_1, x_{18}, x_{19})$ such that during the execution, `CHECK` $(x_0, x_1, x_{18}, x_{19})$ once returned false, and later `P` (x_0, x_1) returned (x_{18}, x_{19}) or `P` $^{-1}(x_{18}, x_{19})$ returned (x_0, x_1) (this can happen if the call to check occurs *before* the first corresponding call to `P` or `P` $^{-1}$).

The event `BadCheck` occurs in \mathbf{R}' if a call to `CHECK'` returns true because of the last line.

Note that conditioned on `BadCheck` not occurring, it is clear that queries to `CHECK` will be answered in the same way as queries to `CHECK'` (and note that conditioning on `ContradictCheck` does not change anything in calls to `CHECK`). Furthermore, conditioned on both events not occurring, the distribution of the answers in queries to `P` and `P` $^{-1}$ is the same: for `P` (x_0, x_1) , if $(\downarrow, x_0, x_1) \notin P$, then it is uniform among all the pairs (x_{18}, x_{19}) for which `CHECK` $(x_0, x_1, x_{18}, x_{19})$ was not previously called.

The probability that the distinguisher can provoke `BadCheck` in \mathbf{R}' is at most $\frac{4q}{2^{2n}}$: for a single call `CHECK'` $(x_0, x_1, x_{18}, x_{19})$ the event `BadCheck` can only occur if neither of the check in the first two lines returns a value, so that we can assume that $(\downarrow, x_0, x_1) \notin P$ and $(\uparrow, x_{18}, x_{19}) \notin P$. Then, the probability that either of the table lookups returns true is at most $\frac{2}{2^{2n}-q} < \frac{4}{2^{2n}}$ (assuming $q < \frac{2^{2n}}{2}$): the value in the table is uniformly chosen from all values which were not previously queried in a corresponding query to `CHECK'`.

The probability that the distinguisher can provoke `ContradictCheck` in \mathbf{R} is at most $\frac{q^2}{2^{2n}}$: for a single query, it only occurs if the randomness chosen (from p) is exactly one of the previously issued queries to `CHECK`. This happens with probability at most $\frac{q}{2^{2n}}$.

In the notation of [Mau02], we have shown $\mathbf{R}|(\neg\text{ContradictCheck}) \equiv \mathbf{R}'|(\neg\text{BadCheck})$. According to [Mau02, Theorem 1 (i)] (which we apply twice), this implies that the distinguisher has advantage at most $\Pr[\text{ContradictCheck occurs}] + \Pr[\text{BadCheck occurs}] \leq \frac{4q+q^2}{2^{2n}}$. \square

3.4 Complexity of the Simulator

In this section we show that the simulator is efficient in scenario S_2 . We will be able to exploit indistinguishability in order to imply that this is also the case in other scenarios.

Lemma 3.6. *Consider S_2 , and suppose that the distinguisher makes at most q queries. Then, the simulator dequeues at most q times a partial chain of the form $(x_1, x_2, 1, \ell)$ for which $(x_1, x_2, 1) \notin \text{CompletedChains}$.*

Proof. Consider such a dequeue call and let $(x_1, x_2, 1, \ell)$ be the partial chain dequeued for which $(x_1, x_2, 1) \notin \text{CompletedChains}$. A chain $(x_1, x_2, 1, \ell)$ is only enqueued when $(x_1, x_2, x_{17}, x_{18})$ is detected, and since neither $G_1(x_1)$ nor $G_{18}(x_{18})$ are ever overwritten, this means that we can find a unique 4-tuple $(x_0, x_1, x_{18}, x_{19})$ associated with $(x_1, x_2, 1)$ for which `CHECK` $(x_0, x_1, x_{18}, x_{19})$ was true at the moment $(x_1, x_2, 1, \ell)$ was enqueued. We can now find a unique query to p which corresponds to $(x_0, x_1, x_{18}, x_{19})$: pick $p(\uparrow, x_{18}, x_{19}) = (x_0, x_1)$ if this was a query and its answer, or otherwise $p(\downarrow, x_0, x_1) = (x_{18}, x_{19})$. This table entry of p was accessed during a call to `P` or `P` $^{-1}$,

and this call was made either by the distinguisher or the simulator. We argue that this call cannot have been by the simulator. The simulator issues such calls only when it completes a chain, and after this completion, it adds $(x_1, x_0 \oplus G_1(x_1), 1)$ to CompletedChains, and so it cannot have been that $(x_1, x_2, 1) \notin$ CompletedChains when it was dequeued. Thus, we found a unique query of the distinguisher associated with this dequeue call, which means that there are at most q such dequeue calls. \square

Lemma 3.3. *Consider S_2 , and suppose that the distinguisher makes at most q queries. Then, at any point in the execution we have $|G_i| \leq 6q^2$ for all i . Furthermore, there are at most $6q^2$ queries to both $\mathbf{R.P}$, and $\mathbf{R.P}^{-1}$, and at most $1296q^8$ queries to $\mathbf{R.CHECK}$.*

Proof. We first show that $|G_9| \leq 2q$ and $|G_{10}| \leq 2q$. Assignments $G_9(x_9) := f(9, x_9)$ and $G_{10}(x_{10}) := f(10, x_{10})$ only happen in two cases: either when the distinguisher directly queries the corresponding value using F, or when the simulator completes a chain $(x_1, x_2, 1, \ell)$ which it dequeued. There can be at most q queries to F, and according to Lemma 3.6 there are at most q such chains which are completed, which implies the bound.

The set G_i can only be enlarged by 1 in the following cases: if the distinguisher queries $F(i, \cdot)$, if a chain of the form $(x_1, x_2, 1, \ell)$ is dequeued and not in CompletedChains, or if a chain $(x_9, x_{10}, 9, \ell)$ is dequeued and not in CompletedChains. There are at most q events of the first kind, at most q events of the second kind (using Lemma 3.6), and at most $|G_9| \cdot |G_{10}| \leq 4q^2$ events of the last kind, giving a total of $4q^2 + 2q \leq 6q^2$.

A query to $\mathbf{R.P}$ or $\mathbf{R.P}^{-1}$ can be made either by the distinguisher, or by the simulator when it completes a chain. At most q events of the first kind, and at most $q + 4q^2$ events of the second kind are possible. Thus, at most $6q^2$ of these queries occur. The number of CHECK queries by the simulator is bounded by $|G_1 \times G_2 \times G_{17} \times G_{18}| \leq (6q^2)^4$. \square

3.5 Equivalence of the Second and the Third Experiment

This section contains the core of our argument: We prove Lemma 3.4, which states that $S_2(f, p)$ and $S_3(h)$ have the same behaviour for uniformly chosen (f, p) and h . For most part of the analysis, we consider the scenario $S_2(f, p)$. We let $G = (G_1, \dots, G_{18})$ be the tuple of tables of the simulator $\mathbf{T}(f)$ in the execution.

3.5.1 Partial chains

Evaluating partial chains. A *partial chain* is a triple $(x_k, x_{k+1}, k) \in \{0, 1\}^n \times \{0, 1\}^n \times \{0, \dots, 18\}$. Given such a partial chain C , and a set of tables $\mathbf{T.G}$ and $\mathbf{R.P}$, it can be that we can move “forward” or “backward” one step in the Feistel construction. This is captured by the functions next and prev. Additionally, the function val^+ and val^- allow us to access additional values of the chain indexed by C , val^+ by invoking next, and val^- by invoking prev. The function val finally gives us the same information in case we do not want to bother about the direction.

Definition 3.7. Fix a set of tables $G = \mathbf{T.G}$ and $P = \mathbf{R.P}$ in an execution of $S_2(f, p)$. Let $C = (x_k, x_{k+1}, k)$ be a partial chain. We define the following procedures (for a chain $C = (x_k, x_{k+1}, k)$, we let $C[1] = x_k$, $C[2] = x_{k+1}$ and $C[3] = k$):

```

1 procedure next( $x_k, x_{k+1}, k$ ):
2   if  $k < 18$  then
3     if  $x_{k+1} \notin G_{k+1}$  then return  $\perp$ 
4      $x_{k+2} := x_k \oplus G_{k+1}(x_{k+1})$ 

```

```

5     return  $(x_{k+1}, x_{k+2}, k + 1)$ 
6   else if  $k = 18$  then
7     if  $(\uparrow, x_{18}, x_{19}) \notin P$  then return  $\perp$ 
8      $(x_0, x_1) := P(\uparrow, x_{18}, x_{19})$ 
9     return  $(x_0, x_1, 0)$ 
10
11  procedure prev( $x_k, x_{k+1}, k$ ):
12    if  $k > 0$  then
13      if  $x_k \notin G_k$  then return  $\perp$ 
14       $x_{k-1} := x_{k+1} \oplus G_k(x_k)$ 
15      return  $(x_{k-1}, x_k, k - 1)$ 
16    else if  $k = 0$  then
17      if  $(\downarrow, x_0, x_1) \notin P$  then return  $\perp$ 
18       $(x_{18}, x_{19}) := P(\downarrow, x_0, x_1)$ 
19      return  $(x_{18}, x_{19}, 18)$ 
20
21  procedure val $_i^+(C)$ 
22    while  $(C \neq \perp) \wedge (C[3] \notin \{i - 1, i\})$  do
23       $C := \text{next}(C)$ 
24    if  $C = \perp$  then return  $\perp$ 
25    if  $C[3] = i$  then return  $C[1]$  else return  $C[2]$ 
26
27  procedure val $_i^-(C)$ 
28    while  $(C \neq \perp) \wedge (C[3] \notin \{i - 1, i\})$  do
29       $C := \text{prev}(C)$ 
30    if  $C = \perp$  then return  $\perp$ 
31    if  $C[3] = i$  then return  $C[1]$  else return  $C[2]$ 
32
33  procedure val $_i(C)$ 
34    if val $_i^+(C) \neq \perp$  return val $_i^+(C)$  else return val $_i^-(C)$ 

```

◇

We use the convention that $\perp \notin G_i$ for any $i \in \{1, \dots, 18\}$. Thus, the expression $\text{val}_i(C) \notin G_i$ means that $\text{val}_i(C) = \perp$ or that $\text{val}_i(C) \neq \perp$ and $\text{val}_i(C) \notin G_i$.

Equivalent partial chains We further use the concept of equivalent partial chains.

Definition 3.8. For a given set of tables G and P , two chains C and D are *equivalent* if they are in the transitive symmetric closure of the relation given by next. ◇

In other words, two chains C and D are equivalent if D can be obtained by applying next or next $^{-1}$ finitely many times on C .

It is possible that two different chains $(x_0, x_1, 0)$ and $(y_0, y_1, 0)$ are equivalent. While we eventually show that for most executions in $S_2(f, p)$ this does not happen, this is not easy to show, and we cannot assume it for most of the following proof.

3.5.2 Bad events and good executions

As usual in indistinguishability proofs, for some pairs (f, p) the system $S_2(f, p)$ does not behave as “it should”. In this section we collect events which we show later to occur with low probability.

We later study $S_2(f, p)$ for pairs (f, p) for which these events do not occur.

All events occur if some unexpected collision happens to one of the partial chains which can be defined with elements of G_1, \dots, G_{18} and P .

Definition 3.9. The set of *table-defined partial chains* contains all chains C for which $\text{next}(C) \neq \perp$ and $\text{prev}(C) \neq \perp$. \diamond

If $C = (x_k, x_{k+1}, k)$ for $k \in \{1, \dots, 17\}$, then C is table-defined if and only if $x_k \in G_k$ and $x_{k+1} \in G_{k+1}$. For $k \in \{0, 18\}$, C is table-defined if the “inner” value is in G_1 or G_{18} , respectively, and a corresponding triple is in P .

Hitting permutations. Whenever we call the two-sided random function, a query to the table p may occur. If such a query has unexpected effects, the event **BadP** occurs.

Definition 3.10. The event **BadP** occurs in an execution of $S_2(f, p)$ if after a call $(x_{18}, x_{19}) := p(\downarrow, x_0, x_1)$ we have one of

- $(\uparrow, x_{18}, x_{19}) \in P$,
- $x_{18} \in G_{18}$.

Also, it occurs if after a call $(x_0, x_1) := p(\uparrow, x_{18}, x_{19})$ we have one of

- $(\downarrow, x_0, x_1) \in P$,
- $x_1 \in G_1$.

\diamond

If **BadP** does not occur, then for chains $C = (x_{18}, x_{19}, 18)$, if we have $\text{next}(C) = \perp$ before an assignment, then $\text{next}(\text{next}(C)) = \perp$ after an assignment. Furthermore, $\text{next}(\text{prev}(C)) \in \{C, \perp\}$ for all chains C .

Chains hitting tables. Consider now a random assignment $G_i(x_i) := f(i, x_i)$. Unless something unexpected happens, such an assignment allows evaluating $\text{next}(C)$ at most *once* more.

Definition 3.11. The event **BadlyHit** occurs if one of the following happens in an execution of $S_2(f, p)$:

- After an assignment $G_k(x_k) := f(k, x_k)$ there is a table-defined chain (x_k, x_{k+1}, k) such that $\text{prev}(\text{prev}(x_k, x_{k+1}, k)) \neq \perp$.
- After an assignment $G_k(x_k) := f(k, x_k)$ there is a table-defined chain $(x_{k-1}, x_k, k-1)$ such that $\text{next}(\text{next}(x_{k-1}, x_k, k-1)) \neq \perp$.

\diamond

Furthermore, if the above happens for some chain C , and C' is a chain equivalent to C before the assignment, we say that C' badly hits the tables.

Colliding chains. Two chains C and D collide if after an assignment suddenly $\text{val}_i(C) = \text{val}_i(D)$, even though this was not expected. More exactly:

Definition 3.12. Let G and P be a set of tables, let $x_k \notin G_k$, and consider two partial chains C and D . An assignment $G_k(x_k) := y$ *badly collides* C and D if for some $\ell \in \{0, \dots, 19\}$ and $\sigma, \rho \in \{+, -\}$ all of the following happen:

- Before the assignment, C and D are not equivalent.
- Before the assignment, $\text{val}_\ell^\sigma(C) = \perp$ or $\text{val}_\ell^\rho(D) = \perp$.
- After the assignment, $\text{val}_\ell^\sigma(C) = \text{val}_\ell^\rho(D) \neq \perp$.

We say that the event **BadlyCollide** occurs in an execution $S_2(f, p)$, if an assignment of the form $G_i(x_i) := f(i, x_i)$ makes two partial chains badly collide, and the two chains are table-defined after the assignment. \diamond

Finally, we say that a pair (f, p) is *good* if none of the above three events happen in an execution of $S_2(f, p)$.

3.5.3 Bad events are unlikely

In this subsection we show that all the bad events we have introduced are unlikely.

Hitting permutations

Lemma 3.13. *Suppose that $S_2(f, p)$ is such that for any (f, p) the tables satisfy $|G_i| \leq T$ for all i and $|P| \leq T$ at any point in the execution. Then, the probability over the choice of (f, p) of the event **BadP** is at most $\frac{2T^2}{2^n}$.*

Proof. For any query to p , only 2 events are possible. In both cases, these events have probability at most $\frac{T}{2^n}$. Since at most T positions of p can be accessed without violating $|P| \leq T$ we get the claim. \square

Chains hitting tables. We now show that the event **BadlyHit** is unlikely.

Lemma 3.14. *Suppose that $S_2(f, p)$ is such that for any (f, p) the tables satisfy $|G_i| \leq T$ for all i and $|P| \leq T$ at any point in the execution. Then, the probability over the choice of (f, p) of the event **BadlyHit** is at most $400 \frac{T^4}{2^n}$.*

Proof. We first bound the probability of the first event, i.e., that after the assignment $G_k(x_k) := f(k, x_k)$ there is a table-defined chain $C = (x_k, x_{k+1}, k)$ such that $\text{prev}(\text{prev}(C)) \neq \perp$.

There are at most T possible choices for x_{k+1} (this also holds if $k = 18!$), and $\text{prev}(\text{prev}(C))$ can only be different from \perp if $x_{k+1} \oplus G_k(x_k)$ has one of at most T different values (namely, it has to be in G_{k-1} in case $k \geq 2$ or in P together with x_1 in case $k = 1$). This happens with probability at most $T^2/2^n$. In total, the probability is at most $36T^2/2^n$ (counting the 18 different choices of k and also the analogous probability for next). \square

Colliding chains We next show that it is unlikely that chains badly collide. First, we give a useful lemma which explains how the chains behave when they do not badly hit G : only one value $\text{val}_i(C)$ can change from \perp to a different value.

Lemma 3.15. *Consider a set of tables G and P , $x_k \notin G_k$, fix a partial chain C , and suppose that C does not badly hit the tables due to the assignment $G_k(x_k) := f(k, x_k)$. Then, for each $\sigma \in \{+, -\}$, at most one value $\text{val}_i^\sigma(C)$ changes from \perp to a different value. Furthermore, if indeed such a value $\text{val}_i^\sigma(C)$ changes from \perp to a different value, then*

$$i = \begin{cases} k + 1 & \text{if } \sigma = +, \\ k - 1 & \text{if } \sigma = - \end{cases}$$

and $\text{val}_k^\sigma(C) = x_k$ before the assignment.

Proof. We give the proof for $\sigma = +$, the other case is symmetric. Thus, suppose that $\text{val}_i^+(C) = \perp$. This means that during the evaluation of $\text{val}_i^+(C)$ at some point the evaluation stopped. This was either because a queried triple was not in P , or because a value x_j was not in G_j during the evaluation. In the first case, the evaluation of $\text{val}_i^+(C)$ will not change due to an assignment to $G_k(x_k)$. In the second case, the evaluation can only change if it stopped because $\text{val}_k^+(C) = x_k$. Then after the assignment, $\text{val}_{k+1}^+(C)$ will change from \perp to a different value. Since C does not badly hit the tables under the assignment, $\text{val}_{k+1}^+(C) \notin G_{k+1}$ after this assignment (in case $k + 1 < 19$), and $(\uparrow, \text{val}_{18}^+(C), \text{val}_{19}^+(C)) \notin P$ (in case $k + 1 = 19$). Thus, there is only one change in the evaluation. \square

Instead of showing that **BadlyCollide** is unlikely, it is slightly simpler to consider the event $(\text{BadlyCollide} \wedge \neg \text{BadlyHit} \wedge \neg \text{BadP})$.

Lemma 3.16. *Suppose that $\mathsf{S}_2(f, p)$ is such that for any (f, p) the tables satisfy $|G_i| \leq T$ for all i and $|P| \leq T$ at any point in the execution. Then, the probability of the event $(\text{BadlyCollide} \wedge \neg \text{BadlyHit} \wedge \neg \text{BadP})$ is at most $30\,000 \frac{T^5}{2^n}$.*

Proof. Fix two table-defined partial chains C, D that are not equivalent, and $\ell \in \{0, \dots, 19\}$. These chains can badly collide for any $\sigma, \rho \in \{+, -\}$. We consider the case where $\sigma = \rho = -$, the arguments for the other combinations are similar.

If these chains badly collide with $\sigma = \rho = -$, at least one of $\text{val}_\ell^-(C) = \perp$ and $\text{val}_\ell^-(D) = \perp$ holds before the assignment, we suppose that the first is the case. We show that the probability that the chains collide and neither of them badly hits the tables is small.

Since no chain badly hits the tables, using Lemma 3.15 the assignment was to $G_{\ell+1}(\text{val}_{\ell+1}^-(C))$. Now, consider the case that $\text{val}_\ell^-(D) = \perp$ before the assignment. Then it must be that $\text{val}_{\ell+1}^-(C) = \text{val}_{\ell+1}^-(D)$ (also because of Lemma 3.15). Since the two chains are not equivalent we have $\text{val}_{\ell+2}^-(C) \neq \text{val}_{\ell+2}^-(D)$. Therefore, after the assignment we have $\text{val}_\ell^-(C) \neq \text{val}_\ell^-(D)$. In the second case, $\text{val}_\ell^-(D) \neq \perp$. In this case, the probability that $\text{val}_\ell^-(C) = \text{val}_\ell^-(D)$ after the assignment is at most $\frac{1}{2^n}$.

There are 4 possibilities for the values of σ and ρ . As previously, there can be at most $19 \cdot T$ such assignments, and the number of table-defined partial chains is at most $19 \cdot T^2$. Thus, the probability that of the event $(\text{BadlyCollide} \wedge \neg \text{BadlyHit} \wedge \neg \text{BadP})$ is at most $\frac{4 \cdot 19 \cdot T \cdot 19^2 \cdot T^4}{2^n}$. \square

Most executions are good We collect our findings in the following lemma:

Lemma 3.17. *Suppose that $S_2(f, p)$ is such that for any (f, p) the tables satisfy $|G_i| \leq T$ for all i and $|P| \leq T$ at any point in the execution. Then, the probability that a uniform randomly chosen (f, p) is not good is at most $31\,000 \cdot \frac{T^5}{2^n}$.*

Proof. This follows immediately from Lemmata 3.14, 3.13, and 3.16. \square

3.5.4 Properties of good executions

We now study executions of $S_2(f, p)$ with good pairs (f, p) . One of the main goals of this section is to prove Lemma 3.25, which states that no call to `FORCEVAL` overwrites a previous entry. However, we later also use Lemma 3.26 (in good executions, evaluating the Feistel construction for a pair (x_0, x_1) leads to $P(x_0, x_1)$ — if not, it would be silly to hope that our simulator emulates a Feistel construction), and Lemma 3.27 (the number of times `ADAPT` is called in $\mathbf{T}(f)$ is exactly the same as the number of times the table p is queried in $\mathbf{R}(p)$).

Lemma 3.18. *Consider an execution of $S_2(f, p)$ with a good pair (f, p) . Suppose that at any point in the execution, two table-defined chains C and D are equivalent. Then, there exists some sequence C_1, \dots, C_r such that*

- $C = C_1$ and $D = C_r$, or else $D = C_1$ and $C = C_r$,
- $C_i = \text{next}(C_{i-1})$ and $C_{i-1} = \text{prev}(C_i)$,
- and each C_i is table-defined.

Proof. In the directed graph whose vertices are chains and where (C', C'') has a directed edge if $C'' = \text{next}(C')$, all vertices have both indegree and outdegree at most 1 as long as `BadP` does not occur. Furthermore, C' has indegree 1 exactly if $\text{prev}(C') \neq \perp$. \square

We first show that assignments $G_i(x_i) := f(i, x_i)$ and also assignments to P and P^{-1} in \mathbf{R} do not change the equivalence relation for chains which were previously defined.

Lemma 3.19. *Consider an execution of $S_2(f, p)$ with a good pair (f, p) . Let C and D be two table-defined partial chains at some point in the execution. Suppose that after this point, there is an assignment $G_i(x_i) := f(i, x_i)$ or a pair of assignments to P in \mathbf{R} . Then C and D are equivalent before the assignment(s) if and only if they are equivalent after the assignment(s).*

Proof. Suppose that C and D are equivalent before the assignment. From Lemma 3.18 we get a sequence $C = C_1, \dots, C_r = D$ of table-defined chains such that C_i and C_{i+1} are directly equivalent. This sequence still implies equivalence after the assignment: since no value in P or G can be overwritten by one of the assignments considered (recall that that `BadP` does not occur), the conditions of Definition 3.8 still hold if they held previously.

Suppose now that C and D are equivalent after the assignment, and again consider the sequence C_1, \dots, C_r as given by Lemma 3.18. Suppose first that the assignment was $G_i(x_i) := f(i, x_i)$. There must be chains $C_{j-1} = (x_{i-1}, x_i, i-1)$ and $C_j = (x_i, x_{i+1}, i)$. It is not possible that $C_j = C_r$, as C_j is not table-defined before the assignment. Thus, after the assignment, $\text{next}(\text{next}(C_{j-1})) \neq \perp$, contradicting that `BadlyHit` does not occur. If the assignment was $P(\uparrow, x_{18}, x_{19}) := (x_0, x_1)$, then there must be $C_j = (x_{18}, x_{19}, 18)$, and again, $\text{next}(\text{next}(C_j)) \neq \perp$, contradicting that `BadP` does not occur. \square

Next, we show that calls to `FORCEVAL` *also* do not change the equivalence relation for previously defined chains. Also, they never overwrite a previously defined value. However, we only show this under the assumption $x_{\ell-2} \notin G_{\ell-2}$ and $x_{\ell+3} \notin G_{\ell+3}$. Later, we will see that this assumption is safe.

Lemma 3.20. *Consider an execution of $S_2(f, p)$ with a good pair (f, p) . Suppose that for a call $\text{ADAPT}(x_{\ell-3}, x_{\ell-2}, x_{\ell+3}, x_{\ell+4}, \ell)$ it holds that $x_{\ell-2} \notin G_{\ell-2}$ and $x_{\ell+3} \notin G_{\ell+3}$ before the call.*

Then, the following properties hold:

- (a) *For both calls $\text{FORCEVAL}(x, \cdot, j)$ we have $x \notin G_j$ before the call.*
- (b) *Let C be a table-defined chain before the call to ADAPT , $i \in \{1, \dots, 18\}$. Then, $\text{val}_i(C)$ stays constant during both calls to FORCEVAL .*
- (c) *Two chains C and D which are table-defined before the calls to ADAPT are equivalent before the calls to FORCEVAL if and only if they are equivalent after the calls to FORCEVAL .*

Proof. Since (f, p) is a good pair, the event `BadP` does not occur. Before `ADAPT` is called, `EVALUATEFORWARD` and `EVALUATEBACKWARD` make sure that all the values $x_{\ell-2}, x_{\ell-3}, \dots, x_0, x_{19}, \dots, x_{\ell+4}, x_{\ell+3}$ corresponding to C are defined. All partial chains defined by these values are equivalent to C (we simply use that `BadP` does not occur, thus the wrap from (x_0, x_1) to (x_{18}, x_{19}) cannot cause any trouble).

By our assumption, $x_{\ell-2} \notin G_{\ell-2}$ and $x_{\ell+3} \notin G_{\ell+3}$, and thus the procedure `ADAPT` defines $G_{\ell-2}(x_{\ell-2}) := f(\ell - 2, x_{\ell-2})$ and $G_{\ell+3}(x_{\ell+3}) := f(\ell + 3, x_{\ell+3})$. These assignments lead to $x_{\ell-1} \notin G_{\ell-1}$ and $x_{\ell+2} \notin G_{\ell+2}$, as otherwise the event `BadlyHit` would occur. Repeating the same argument shows that after the next two assignments in `ADAPT`, $x_\ell \notin G_\ell$ and $x_{\ell+1} \notin G_{\ell+1}$, which shows (a).

We next show (b), i.e., for any C the values $\text{val}_i(C)$ stay constant. For this, note first that this is true for chains equivalent to $(x_{\ell-3}, x_{\ell-2}, \ell - 3)$, because val_i gives exactly x_i both before and after the calls to `FORCEVAL`.

For the other chains, we show that even $\text{val}_i^+(C)$ and $\text{val}_i^-(C)$ stay constant, as otherwise `BadlyCollide` would occur. A value $\text{val}_i^+(C)$ can only change during the execution of $\text{FORCEVAL}(x_\ell, \cdot, \ell)$ if $\text{val}_\ell^+(C) = x_\ell$. But this implies that the assignment $G(x_{\ell-1}) := f(\ell - 1, x_{\ell-1})$ in `ADAPT` made the two partial chains C and $(x_{\ell-2}, x_{\ell-1}, \ell - 2)$ badly collide. The argument for $\text{FORCEVAL}(x_{\ell+1}, \cdot, \ell + 1)$ is the same. Thus, this establishes (b).

We now show (c). If C and D are equivalent before the calls to `FORCEVAL`, they are equivalent afterwards (using (a)). If C and D are equivalent after the calls to `FORCEVAL`, let C_1, \dots, C_r be the sequence from Lemma 3.18. If C and D were not equivalent before the calls to `FORCEVAL`, there was C_{i+1} which was not table-defined. Then, $\text{val}^+(C_i)$ changes during a call to `FORCEVAL`, contradicting the proof of (b). \square

Equivalent chains are put into `CompletedChains` simultaneously:

Lemma 3.21. *Suppose that (f, p) is good. Fix a point in the execution of $S_2(f, p)$, and suppose that until this point, for no call to `FORCEVAL` of the form $\text{FORCEVAL}(x, \cdot, \ell)$ we had $x \in G_\ell$ before the call. Suppose that at this point $C = (x_k, x_{k+1}, k)$ with $k \in \{1, 9\}$ and $D = (y_m, y_{m+1}, m)$ with $m \in \{1, 9\}$ are equivalent. Then, $C \in \text{CompletedChains}$ if and only if $D \in \text{CompletedChains}$.*

Proof. We first show that the lemma holds right after C was added to `CompletedChains`. At this moment, the only chains which are equivalent to C are those of the form $(\text{val}_i(C), \text{val}_{i+1}(C), i)$ because evaluating the Feistel construction one round forward (or backward) is a bijection, and because `BadP` never occurs, the same holds for evaluations of P and P^{-1} .

Now, this bijective property can only be lost if the event `BadP` occurs or else if a value is overwritten by `FORCEVAL`. Thus, we get the lemma. \square

If the simulator detects a chain $(x_9, x_{10}, 9)$ for which val^+ is defined for enough values, a chain equivalent to it was previously enqueued:

Lemma 3.22. *Consider an execution of $\mathcal{S}_2(f, p)$ with a good pair (f, p) . Suppose that at some point, a chain $C = (x_9, x_{10}, 9)$ is enqueued for which $\text{val}_2^+(C) \in G_2$ or $\text{val}_{17}^-(C) \in G_{17}(C)$. Then, there is a chain equivalent to C which was previously enqueued.*

Proof. We only consider the case $\text{val}_2^+(C) \in G_2$, the other case is symmetric. Define $(x_0, x_1, x_2, x_{17}, x_{18}, x_{19}) := (\text{val}_0^+(C), \text{val}_1^+(C), \text{val}_2^+(C), \text{val}_{17}^+(C), \text{val}_{18}^+(C), \text{val}_{19}^+(C))$. All these must be different from \perp , since otherwise $\text{val}_2^+(C) = \perp$.

At some point in the execution, all the following entries are set in their respective hashtables: $G_1(x_1), G_2(x_2), G_{17}(x_{17}), G_{18}(x_{18})$, and $P(\uparrow, x_{18}, x_{19})$. The last one of these must have been $G_2(x_2)$ or $G_{17}(x_{17})$: if it was $P(\uparrow, x_{18}, x_{19})$, then the event `BadP` must have happened. If it was $G_1(x_1)$, then the event `BadlyHit` must have happened (as $(x_0, x_1, 0)$ is table-defined after the assignment). Analogously, $G_{18}(x_{18})$ cannot have been the last one. Thus, since $G_2(x_2)$ or $G_{17}(x_{17})$ was defined last among those, the simulator will detect the chain and enqueue it. \square

If a chain C is enqueued for which previously no equivalent chain has been enqueued, then the assumption of Lemma 3.20 actually *does* hold in good executions. We first show that they hold at the moment when the chains are enqueued (Lemma 3.23), and then that they still hold when the chains are dequeued (Lemma 3.24).

Lemma 3.23. *Consider an execution of $\mathcal{S}_2(f, p)$ with a good pair (f, p) . Let C be a partial chain which is enqueued in the execution at some time and to be completed at position ℓ . Suppose that at the moment the chain is enqueued, no equivalent chain has been previously enqueued.*

Then, before the assignment $G_k(x_k) := f(k, x_k)$ happens which just precedes C being enqueued, $\text{val}_{\ell-2}(C) = \perp$ and $\text{val}_{\ell+3}(C) = \perp$.

Proof. We have $\ell \in \{5, 13\}$. We will assume $\ell = 5$, and due to symmetry of the construction, this also implies the lemma in case $\ell = 13$ for the corresponding rounds.

The assignment sets either the value of $G_9(x_9)$ or $G_2(x_2)$ uniformly (otherwise, `ENQUEUENEWCHAINS` is not called in the simulator). Consider first the case that $G_2(x_2)$ was just set. Then, before this happened, $\text{val}_3^+(C) = \perp$, since $x_2 \notin G_2$. Furthermore, $\text{val}_8^-(C) = \perp$, since otherwise, $\text{val}_9^-(C) \in G_9$, and then $(\text{val}_9^-(C), \text{val}_{10}^-(C), 9)$ would be an equivalent, previously enqueued chain. This implies the statement in case $G_2(x_2)$ is just set. The second case is if $G_9(x_9)$ was just set. Then, before the assignment, $\text{val}_8^-(C) = \perp$, as $x_9 \notin G_9$, and $\text{val}_3^+(C) = \perp$, since otherwise $\text{val}_2^+(C) \in G_2$ and so an equivalent chain would have been previously enqueued, according to Lemma 3.22. \square

Lemma 3.24. *Consider an execution of $\mathcal{S}_2(f, p)$ with a good pair (f, p) . Let C be a partial chain which is enqueued in the execution at some time and to be completed at position ℓ .*

Then, at the moment C is dequeued, it holds that $C \in \text{CompletedChains}$, or that $(\text{val}_{\ell-2}(C) \notin G_{\ell-2}) \wedge (\text{val}_{\ell+3}(C) \notin G_{\ell+3})$.

Proof. Suppose that the lemma is wrong, and let C be the first chain for which it fails. Because this is the first chain for which it fails, Lemma 3.20(a) implies that until the moment C is dequeued, no call to `FORCEVAL` overwrote a value. Now, consider the set \mathfrak{C} of table-defined chains at some point before C is dequeued. Because of Lemmas 3.19 and 3.20(c), the equivalence relation among chains in \mathfrak{C} stays constant from this point until the moment C is dequeued.

We distinguish two cases to prove the lemma. Consider first the case that at the moment C is enqueued, an equivalent chain D was previously enqueued. Then, at the moment C is dequeued, clearly $D \in \text{CompletedChains}$. Because of Lemma 3.21 and the remark about equivalence classes of \mathfrak{C} above, this implies that $C \in \text{CompletedChains}$ when it is dequeued.

The second case is when C has no equivalent chain which was previously enqueued. To simplify notation we assume $\ell = 5$ and show $\text{val}_3(C) \notin G_3$, but the argument is completely generic. From Lemma 3.23 we get that before the assignment which led to C being enqueued, $\text{val}_3(C) = \perp$. If $\text{val}_3(C) \in G_3$ at the time C is dequeued, it must be $G_3(\text{val}_3(C))$ was set during completion of a chain D . This chain D was enqueued before C was enqueued, and dequeued after C was enqueued. Also, at the moment C is dequeued, $\text{val}_3(C) = \text{val}_3(D)$. Furthermore, D cannot be equivalent to C because of the remark about the equivalence classes of \mathfrak{C} above and the fact that C had no previously enqueued chain equivalent to C when it was enqueued.

Consider now the last assignment to a table before $\text{val}_3(C) = \text{val}_3(D) \neq \perp$ was true. This assignment cannot have been of the form $G_i(x_i) := f(i, x_i)$, as otherwise the event `BadlyCollide` would have happened (note that after the assignment, both C and D are table-defined, because this assignment happens earliest right before C is enqueued, and then D is already defined). Also, it cannot have been an assignment of the form $P(\downarrow, x_0, x_1) = (x_{18}, x_{19})$ or $P(\uparrow, x_{18}, x_{19}) = (x_0, x_1)$, as otherwise the event `BadP` would have happened. Also, it cannot be a call to `FORCEVAL`, because of Lemma 3.20(b).

Thus, $\text{val}_3(C) \notin G_3$ when C is dequeued, and the same argument holds for the other cases as well. \square

The following lemma is an important intermediate goal. It states that the simulator never overwrites a value in G in case (f, p) is good.

Lemma 3.25. *Suppose that (f, p) is good. Then, for any call to `FORCEVAL` of the form `FORCEVAL` (x, \cdot, ℓ) we have $x \notin G_\ell$.*

Proof. Assume otherwise, and let C be the first chain during completion of which the lemma fails. Clearly, because of Lemma 3.24 no chain equivalent to C was enqueued before C was enqueued.

However, then Lemma 3.24 implies that $\text{val}_{\ell-2}(C) \notin G_{\ell-2}$ and $\text{val}_{\ell+3}(C) \notin G_{\ell+3}(C)$, and so by Lemma 3.20(a), we get the result. \square

We say that a *distinguisher completes all chains*, if, at the end of the execution, it emulates a call to `EVALUATEFORWARD` $(x_0, x_1, 0, 18)$ for all queries to $P(x_0, x_1)$ or to $(x_0, x_1) = P^{-1}(x_{18}, x_{19})$ which it made during the execution.

Lemma 3.26. *Consider an execution of $\mathbb{S}_2(f, p)$ with a good pair (f, p) in which the distinguisher completes all chains. Suppose that during the execution $P(\downarrow, x_0, x_1)$ is queried. Then, at the end of the execution it holds that $P(\downarrow, x_0, x_1) = (\text{val}_{18}^+(x_0, x_1, 0), \text{val}_{19}^+(x_0, x_1, 0))$. Furthermore, the analogous statement for $P(\uparrow, x_{18}, x_{19})$ and val^- also holds.*

Proof. If the query $P(\downarrow, x_0, x_1)$ was made by the simulator, then this was while it was completing a chain. Then, right after it finished adapting we clearly have the result. By Lemma 3.25 no value is ever overwritten. Since the event `BadP` does not occur, the conclusion of the lemma must also be true at the end of the execution.

Consider now the case that $P(\downarrow, x_0, x_1)$ was a query by the distinguisher. Since it eventually issues the corresponding Feistel queries, it must query the corresponding values x_9 and x_{10} at some point. Thus, $x_9 \in G_9$ and $x_{10} \in G_{10}$ at the end of the execution. One of the two values was defined later, and in that moment, $(x_9, x_{10}, 9)$ was enqueued by the simulator. Thus, it is dequeued at

some point. If it was not in CompletedChains at this point, it is now completed and the conclusion of the lemma holds right after this completion. Otherwise, it was completed before it was inserted in CompletedChains, and the conclusion of the lemma holds after this completion. Again, by Lemma 3.25 no value is ever overwritten, and again BadP never occurs, hence the conclusion also holds at the end of the execution. \square

Lemma 3.27. *Consider an execution of $S_2(f, p)$ with a good pair (f, p) in which the distinguisher completes all chains. Then, the number of calls to ADAPT by the simulator equals the number of queries to $p(\cdot, \cdot, \cdot)$ made by the two-sided random function.*

Proof. Since the event BadP does not occur, the number of queries to $p(\cdot, \cdot, \cdot)$ equals half the number of entries in P at the end of the execution.

For each call to ADAPT, there is a corresponding pair of entries in P : just before ADAPT was called, such an entry was read either in EVALUATEFORWARD or EVALUATEBACKWARD. Furthermore, for no other call to ADAPT the same entry was read, as otherwise a value would have to be overwritten, contradicting Lemma 3.25.

For each query to $p(\cdot, \cdot, \cdot)$, there was a corresponding call to ADAPT. If the query to p occurred in a call to P by the simulator, then we consider the call to ADAPT just following this call (as the simulator only queries P right before it adapts). If the query to p occurred in a call by the distinguisher, the distinguisher eventually queries the corresponding Feistel chain. At the moment it queries $G_{10}(x_{10})$, we find the first chain which is equivalent to $(x_9, x_{10}, 9)$ at this point and was enqueued. This chain must have been adapted according. \square

3.5.5 Mapping randomness of S_2 to randomness of S_3

We next define a map τ which maps a pair of tables (f, p) to a partial table h , where a partial table $h : \{1, \dots, 18\} \times \{0, 1\}^n \mapsto \{0, 1\}^n \cup \{\perp\}$ either has an actual entry for a pair (i, x) , or a symbol \perp which signals that the entry is unused. This map will be such that $S_2(f, p)$ and $S_3(\tau(f, p))$ have “exactly the same behaviour”.

Definition 3.28. The function $h = \tau(f, p)$ is defined as follows: Run a simulation of $S_2(f, p)$ in which the distinguisher completes all chains. If $f(i, x)$ is read at some point, then $h(i, x) := f(i, x)$. If $f(i, x)$ is never read, but for some y a call FORCEVAL(i, x, y) occurs, then $h(i, x) := y$ for the first such call. If $f(i, x)$ is never read and no such call to FORCEVAL occurs, then $h(i, x) := \perp$. \diamond

Lemma 3.29. *Suppose h has a good preimage. Consider any execution of $S_3(h)$ and suppose the distinguisher completes all chains. Then, $S_3(h)$ never queries h on an index (i, x) for which $h(i, x) = \perp$. Furthermore, the following two conditions on (f, p) are equivalent:*

- (1) *The pair (f, p) is good and $\tau(f, p) = h$.*
- (2) *The queries and answers to the two-sided random function in $S_2(f, p)$ are exactly the same as the queries and answers to the Feistel construction in $S_3(h)$; and $h(i, x) = f(i, x)$ for any query (i, x) issued to f or h by the simulator.*

Proof. We first show that (1) implies (2). Because the distinguisher is deterministic, we need to show the following:

- When the simulator sets $G_i(x_i) := f(i, x_i)$, respectively $G_i(x_i) := h(i, x_i)$, the two values are the same.

- When the simulator queries $P(x_0, x_1)$ or $P^{-1}(x_{18}, x_{19})$ it gets a the same answer in $S_2(f, p)$ and $S_3(h)$.

The first bullet is obvious, because if the simulator ever sets $G_i(x_i) := f(i, x_i)$ in $S_2(f, p)$, then h will be set accordingly by definition of τ .

Thus, we consider a query to $P(x_0, x_1)$ (queries to P^{-1} are handled in the same way). Recall that we assume that the distinguisher completes all chains. Because of Lemma 3.26, the answer of the query to P is exactly what we obtain by evaluating the Feistel construction at the end in experiment S_2 . But each query in the evaluation of the Feistel construction was either set as $G_i(x_i) := f(i, x_i)$ or in a `FORCEVAL` call, and in both cases the values of h must agree, since in good executions no value is ever overwritten (Lemma 3.25). Thus, the query to P is answered by the Feistel in the same way.

Thus, assume now that (2) holds. Let (f_h, p_h) be a good preimage of h , i.e., a pair satisfying (1). We know already that condition (2) holds for (f_h, p_h) , and because we assume that it holds for (f, p) , we see that in the two executions $S_2(f_h, p_h)$ and $S_2(f, p)$ all queries to the two-sided random function are the same, and also the entries $f(i, x)$ for values considered match. This implies that (f, p) must be good. Furthermore, this implies $\tau(f, p) = \tau(f_h, p_h)$.

Finally, we argue that $S_3(h)$ never queries h on an index (i, x) for which $h(i, x) = \perp$. However, since h has a good preimage (f_h, p_h) for which (2) holds, we consider the definition of τ again and see that this must be true. \square

Lemma 3.30. *Suppose h has a good preimage. Pick (f, p) uniformly at random. Then,*

$$\Pr[(f, p) \text{ is good} \wedge \tau(f, p) = h] = 2^{-n|h|}, \quad (1)$$

where $|h|$ is the number of pairs (i, x) for which $h(i, x) \neq \perp$.

Proof. Let (f_h, p_h) be a good preimage of h . With probability $2^{-n|h|}$ all queries in $S_2(f, p)$ are answered exactly as those in $S_2(f_h, p_h)$: every query to f is answered the same with probability 2^{-n} , and every query to p with probability 2^{-2n} . Because of Lemma 3.27 the number $|h|$ of non-nil entries in h is exactly the number of queries to f plus twice the number of queries to p . \square

Lemma 3.4. *The probability that a fixed distinguisher answers 1 in $S_2(f, p)$ differs at most by $\text{poly}(q)/2^n$ from the probability that it answers 1 in $S_3(\tau(f, p))$.*

Proof. First, modify the distinguisher such that for each query $P(x_0, x_1)$ and each query $P^{-1}(x_{18}, x_{19})$ which it issues (to either the two-sided random function or the Feistel construction), it eventually issues the corresponding Feistel queries to F (i.e., it emulates a call to `EVALUATEFORWARD`($x_0, x_1, 0, 18$)).

Consider first the following distribution over values h^* , which are either tables for $S_3(h^*)$ which contain no entry \perp , or special symbols \perp . To pick an element h^* , we pick a pair (f, p) uniformly at random. If (f, p) is good, we compute $h := \tau(f, p)$ and set each entry of h with $h(i, x) = \perp$ uniformly at random. The result is h^* . If (f, p) is not good, we set $h^* = \perp$.

The probability that any fixed table $h^* \neq \perp$ is output is at most $2^{-n|h^*|}$: First, it cannot be that two different values h which both have a good preimage can yield the same h^* . The reason is that otherwise, due to Lemma 3.30, item (2), all the queries and answers of the Feistel construction would be the same, which clearly implies that the two values for h^* coincide. Thus, the probability of getting a fixed table h^* is $2^{-n(|h|+|h^*|-|h|)}$ in case there exists h with a good preimage which can lead to h^* , and 0 otherwise. In particular, it is always at most the probability of getting h^* when we pick it uniformly at random.

This implies that the statistical distance of the distribution over h^* which we described to the uniform distribution is exactly the probability that (f, p) is not good. Combining Lemma 3.17 with Lemma 3.3, this is at most $\frac{\text{poly}(q)}{2^n}$. \square

References

- [BK03] Mihir Bellare and Tadayoshi Kohno. A theoretical treatment of related-key attacks: RKA-PRPs, RKA-PRFs, and applications. In *Advances in Cryptology — EUROCRYPT 2003*, volume 2656 of *Lecture Notes in Computer Science*, pages 491–506, 2003.
- [BR93] Mihir Bellare and Phillip Rogaway. Random oracles are practical: a paradigm for designing efficient protocols. In *CCS '93: Proceedings of the 1st ACM conference on Computer and communications security*, pages 62–73, New York, NY, USA, 1993. ACM.
- [BR94] Mihir Bellare and Phillip Rogaway. Optimal asymmetric encryption. In *Advances in Cryptology — EUROCRYPT '94*, *Lecture Notes in Computer Science*, pages 92–111, 1994.
- [BR96] Mihir Bellare and Phillip Rogaway. The exact security of digital signatures - How to sign with RSA and Rabin. In *Advances in Cryptology — EUROCRYPT '96*, *Lecture Notes in Computer Science*, pages 399–416, 1996.
- [BR06] Mihir Bellare and Phillip Rogaway. The security of triple encryption and a framework for code-based game-playing proofs. In *Advances in Cryptology — EUROCRYPT 2006*, volume 4004 of *Lecture Notes in Computer Science*, pages 409–426, 2006.
- [BRS02] John Black, Phillip Rogaway, and Thomas Shrimpton. Black-box analysis of the block-cipher-based hash-function constructions from pgv. In *Advances in Cryptology — CRYPTO 2002*, volume 2442 of *Lecture Notes in Computer Science*, pages 320–335, 2002.
- [Can01] Ran Canetti. Universally composable security: A new paradigm for cryptographic protocols. In *FOCS '01: Proceedings of the 42nd IEEE Annual Symposium on Foundations of Computer Science*, pages 136–145, 2001.
- [CDMP05] Jean-Sébastien Coron, Yevgeniy Dodis, Cécile Malinaud, and Prashant Puniya. Merkle–Damgård revisited: How to construct a hash function. *Lecture Notes in Computer Science*, pages 430–448, 2005.
- [CGH04] Ran Canetti, Oded Goldreich, and Shai Halevi. The random oracle methodology, revisited. *J. ACM*, 51(4):557–594, 2004.
- [CPS08a] Jean-Sebastien Coron, Jacques Patarin, and Yannick Seurin. The random oracle model and the ideal cipher model are equivalent. Cryptology ePrint Archive, Report 2008/246, May 2008. Version: 20080603:012059, <http://eprint.iacr.org/>.
- [CPS08b] Jean-Sebastien Coron, Jacques Patarin, and Yannick Seurin. The random oracle model and the ideal cipher model are equivalent. Cryptology ePrint Archive, Report 2008/246, August 2008. Version: 20080816:121712, <http://eprint.iacr.org/>, Extended Abstract at CRYPTO 2008.

- [Dam89] Ivan B. Damgård. A design principle for hash functions. In *Advances in Cryptology — CRYPTO '89*, volume 435 of *Lecture Notes in Computer Science*, pages 416–427, 1989.
- [DP06] Yevgeniy Dodis and Prashant Puniya. On the relation between the ideal cipher and the random oracle models. In *Theory of Cryptography — TCC 2006*, volume 3876 of *Lecture Notes in Computer Science*, pages 184–206, 2006.
- [GM09] Peter Gaži and Ueli Maurer. Cascade encryption revisited. In *Advances in Cryptology — ASIACRYPT 2009*, volume 5912 of *Lecture Notes in Computer Science*, pages 37–51, December 2009.
- [HKT10] Thomas Holenstein, Robin Künzler, and Stefano Tessaro. The equivalence of the random oracle model and the ideal cipher model, revisited, 2010. Available on [arXiv.org](http://arxiv.org).
- [KOS10] Eike Kiltz, Adam O’Neill, and Adam Smith. Instantiability of rsa-oaep under chosen-plaintext attack. In *Advances in Cryptology — CRYPTO 2009*, volume 6223 of *Lecture Notes in Computer Science*, pages 295–313, 2010.
- [Kün09] Robin Künzler. Are the random oracle and the ideal cipher models equivalent? Master’s thesis, ETH Zurich, Switzerland, 2009. Available on <http://www.complexity.ethz.ch/>.
- [LR88] Michael Luby and Charles Rackoff. How to construct pseudorandom permutations from pseudorandom functions. *SIAM J. Comput.*, 17(2):373–386, 1988.
- [Mau02] Ueli Maurer. Indistinguishability of random systems. In *Advances in Cryptology — EUROCRYPT 2002*, volume 2332 of *Lecture Notes in Computer Science*, pages 110–132, 2002.
- [Mer89] Ralph C. Merkle. A certified digital signature. In *Advances in Cryptology — CRYPTO '89*, volume 435 of *Lecture Notes in Computer Science*, pages 218–238, 1989.
- [MRH04] Ueli Maurer, Renato Renner, and Clemens Holenstein. Indifferentiability, impossibility results on reductions, and applications to the random oracle methodology. In *Theory of Cryptography Conference — TCC 2004*, volume 2951 of *Lecture Notes in Computer Science*, pages 21–39, February 2004.
- [Rud89] Steven Rudich. *Limits on the Provable Consequences of One-way Functions*. PhD thesis, 1989.
- [Seu09] Yannick Seurin. *Primitives et protocoles cryptographiques à sécurité prouvée*. PhD thesis, Université de Versailles Saint-Quentin-en-Yvelines, UFR de Sciences - École doctorale SoFt - Laboratoire PRiSM, 2009.
- [Sho04] Victor Shoup. Sequences of games: A tool for taming complexity in security proofs, 2004.

A Detailed Definition of the Simulator of Coron et al.

We proceed to provide the full definition of the simulator in [CPS08b]. In particular, for ease of reference, we stick to the same variable naming used within their work, even though this is inconsistent with the notation used in the rest of this paper.

As sketched in the simulator overview, \mathbf{S} keeps a *history* of the function values it has defined up to the current point of execution, which consist of sets $\mathcal{H}(\mathbf{F}_i)$ of pairs $(x, \mathbf{F}_i(x))$. With some abuse of notation, and to improve readability, we denote as $\mathbf{F}_i := \{x \mid (x, \mathbf{F}_i(x)) \in \mathcal{H}(\mathbf{F}_i)\}$ the set of \mathbf{F}_i -queries whose values have been defined. We define the history $\mathcal{H} := \{(x, \mathbf{F}_i(x), i) \mid (x, \mathbf{F}_i(x)) \in \mathcal{H}(\mathbf{F}_i) \text{ for some } i\}$.

Also, if the history size gets too big, i.e. $|\mathcal{H}(\mathbf{F}_i)| > h_{\max}$ for some \mathbf{F}_i and a value h_{\max} depending only on the number of distinguisher queries q , the simulator aborts.

Procedures QUERY and CHAINQUERY. Upon a query x for \mathbf{F}_k issued by \mathbf{D} , the simulator \mathbf{S} executes the following procedure $\text{QUERY}(x, k)$:

```

1 procedure QUERY( $x, k$ ):
2   if  $x \in \mathbf{F}_k$  then
3     return  $\mathbf{F}_k(x)$  from  $\mathcal{H}(\mathbf{F}_k)$ 
4   else
5      $\mathbf{F}_k(x) \leftarrow_{\mathbf{R}} \{0, 1\}^n$ 
6     CHAINQUERY( $x, k$ )
7   return  $\mathbf{F}_k(x)$  from  $\mathcal{H}(\mathbf{F}_k)$ 

```

Procedure CHAINQUERY checks if 3-chains as defined in Fig. 3 w.r.t. query x occur. Note that this is only a selection of all possible chains one might consider. Observe that the chain sets for $\mathbf{F}_1, \mathbf{F}_2$ and \mathbf{F}_3 are defined symmetrically to those of $\mathbf{F}_4, \mathbf{F}_5$ and \mathbf{F}_6 . In particular, the sets \mathbf{F}_6^* and \mathbf{F}_1^* are

Query to	Chain Sets
\mathbf{F}_1	$\mathcal{C}(-, R, 1) = \{(S, A) \in (\mathbf{F}_6, \mathbf{F}_5) \mid \mathbf{P}^{-1}(S \parallel A \oplus \mathbf{F}_6(S)) _2 = R\}$
\mathbf{F}_2	$\mathcal{C}(+, X, 2) = \{(Y, Z) \in (\mathbf{F}_3, \mathbf{F}_4) \mid X = \mathbf{F}_3(Y) \oplus Z\}$ $\mathcal{C}(-, X, 2) = \{(R, S) \in (\mathbf{F}_1, \mathbf{F}_6^*(X)) \mid \mathbf{P}(X \oplus \mathbf{F}_1(R) \parallel R) _1 = S\}$
\mathbf{F}_3	$\mathcal{C}(+, Y, 3) = \{(Z, A) \in (\mathbf{F}_4, \mathbf{F}_5) \mid Y = \mathbf{F}_4(Z) \oplus A\}$
\mathbf{F}_4	$\mathcal{C}(-, Z, 4) = \{(Y, X) \in (\mathbf{F}_3, \mathbf{F}_2) \mid Z = \mathbf{F}_3(Y) \oplus X\}$
\mathbf{F}_5	$\mathcal{C}(+, A, 5) = \{(S, R) \in (\mathbf{F}_6, \mathbf{F}_1^*(A)) \mid \mathbf{P}^{-1}(S \parallel A \oplus \mathbf{F}_6(S)) _2 = R\}$ $\mathcal{C}(-, A, 5) = \{(Z, Y) \in (\mathbf{F}_4, \mathbf{F}_3) \mid A = \mathbf{F}_4(Z) \oplus Y\}$
\mathbf{F}_6	$\mathcal{C}(+, S, 6) = \{(R, X) \in (\mathbf{F}_1, \mathbf{F}_2) \mid \mathbf{P}(X \oplus \mathbf{F}_1(R) \parallel R) _1 = S\}$

Figure 3: Chains to be considered by Procedure CHAINQUERY.

defined as follows for the understood parameters X and A :

$$\mathbf{F}_6^*(X) := \mathbf{F}_6 \cup \{S \mid \exists (R', X') \in (\mathbf{F}_1, \mathbf{F}_2 \setminus \{X\}), \mathbf{P}(X' \oplus \mathbf{F}_1(R') \parallel R')|_1 = S\}$$

$$\mathbf{F}_1^*(A) := \mathbf{F}_1 \cup \{R \mid \exists (S', A') \in (\mathbf{F}_6, \mathbf{F}_5 \setminus \{A\}), \mathbf{P}^{-1}(S' \parallel A' \oplus \mathbf{F}_6(S'))|_2 = R\}$$

The chains that are considered additionally when using the sets \mathbf{F}_i^* instead of \mathbf{F}_i in the cases of $(\mathbf{F}_2, -)$ and $(\mathbf{F}_5, +)$ chains are called *virtual chains*. These chains do not consist of history values exclusively. If such a chain occurs, the simulator first defines the three values that constitute the 3-chain that are not yet in the history and then completes it. The intuition¹⁴ why such virtual chains are considered in addition is as follows: Every time the sets $\mathcal{C}(-, R, 1)$ for some R and symmetrically $\mathcal{C}(+, S, 6)$ for some S are computed, it will not be possible that more than one such chain is found. Note that it is not clear at this point if this goal can indeed be achieved. Intuitively, such a fact might simplify (or even make possible) the analysis of the recursions of the simulator.

¹⁴This intuition comes from studying the proof in [CPS08a]

The procedure CHAINQUERY now handles the recursions. We still consider the chains in Fig. 3. If such 3-chains occur, CHAINQUERY calls a further procedure, called COMPLETECHAIN, to complete these chains, i.e. it consistently (with \mathbf{P}) fills in the remaining values for each 3-chain. Then, CHAINQUERY is called recursively for the values defined during the completions of chains:

```

8 procedure CHAINQUERY( $x, k$ ):
9   if  $k \in \{1, 2, 5, 6\}$  then XORQUERY1( $x, k$ )
10  if  $k \in \{1, 3, 4, 6\}$  then XORQUERY2( $x, k$ )
11  if  $k \in \{3, 4\}$  then XORQUERY3( $x, k$ )
12   $\mathcal{U} := \emptyset$ 
13  if  $k \in \{2, 3, 5, 6\}$  then
14    forall  $(y, z) \in \mathcal{C}(+, x, k)$  do
15       $\mathcal{U} := \mathcal{U} \cup \text{COMPLETECHAIN}(+, x, y, z, k)$ 
16  if  $k \in \{1, 2, 4, 5\}$  then
17    forall  $(y, z) \in \mathcal{C}(-, x, k)$  do
18       $\mathcal{U} := \mathcal{U} \cup \text{COMPLETECHAIN}(-, x, y, z, k)$ 
19  forall  $(x', k') \in \mathcal{U}$  do
20    CHAINQUERY( $x', k'$ )

```

The first three lines of CHAINQUERY make calls to the so-called XORQUERY procedures: they perform additional CHAINQUERY(x', k') executions for values x' other than x that fulfill certain properties. This ensures that for the values x' , we are always sure that CHAINQUERY(x', k') occurs *before* the chains for CHAINQUERY(x, k) are completed. To understand \mathbf{S} one can ignore, for the moment, the details about the XORQUERY procedures: We first detail COMPLETECHAIN and only subsequently address the XORQUERY procedures.

Procedure COMPLETECHAIN. Procedure COMPLETECHAIN completes a chain (x, y, z) , given direction d and the index k of \mathbf{F}_k according to the following table.

Query x to \mathbf{F}_k	Dir d	(y, z) in History	Additionally set \mathbf{F}_i	Compute	Adapt $(\mathbf{F}_j, \mathbf{F}_{j+1})$
\mathbf{F}_1	–	$(\mathbf{F}_6, \mathbf{F}_5)$	\mathbf{F}_4	$S T$	$(\mathbf{F}_2, \mathbf{F}_3)$
\mathbf{F}_2	+	$(\mathbf{F}_3, \mathbf{F}_4)$	\mathbf{F}_1	$L R$	$(\mathbf{F}_5, \mathbf{F}_6)$
	–	$(\mathbf{F}_1, \mathbf{F}_6)$	\mathbf{F}_3	$L R$	$(\mathbf{F}_4, \mathbf{F}_5)$
\mathbf{F}_3	+	$(\mathbf{F}_4, \mathbf{F}_5)$	\mathbf{F}_6	$S T$	$(\mathbf{F}_1, \mathbf{F}_2)$
\mathbf{F}_4	–	$(\mathbf{F}_3, \mathbf{F}_2)$	\mathbf{F}_1	$L R$	$(\mathbf{F}_5, \mathbf{F}_6)$
\mathbf{F}_5	+	$(\mathbf{F}_6, \mathbf{F}_1)$	\mathbf{F}_4	$S T$	$(\mathbf{F}_2, \mathbf{F}_3)$
	–	$(\mathbf{F}_4, \mathbf{F}_3)$	\mathbf{F}_6	$S T$	$(\mathbf{F}_1, \mathbf{F}_2)$
\mathbf{F}_6	+	$(\mathbf{F}_1, \mathbf{F}_2)$	\mathbf{F}_3	$L R$	$(\mathbf{F}_4, \mathbf{F}_5)$

In detail this looks as follows:

```

21 procedure COMPLETECHAIN( $d, x, y, z, k$ ):
22    $\mathcal{U} := \emptyset$ 
23   if there was a COMPLETECHAIN–execution w.r.t.  $\tilde{\cdot}$  values  $x, y, z$  before then
24     return  $\mathcal{U}$ 
25   else
26     if  $(d, k) = (-, 2)$  and  $z \notin \mathbf{F}_6$  then
27        $\mathbf{F}_6(z) \leftarrow_{\mathbf{R}} \{0, 1\}^n$ 

```

```

28      $\mathcal{U} := \mathcal{U} \cup \{(z, 6)\}$ 
29   if  $(d, k) = (+, 5)$  and  $z \notin \mathbf{F}_1$  then
30      $\mathbf{F}_1(z) \leftarrow_{\mathbf{R}} \{0, 1\}^n$ 
31      $\mathcal{U} := \mathcal{U} \cup \{(z, 1)\}$ 
32   compute  $x_i$  ( $i$  according to the table, additional 'set')
33   if  $x_i \notin \mathbf{F}_i$  then
34      $\mathbf{F}_i(x_i) \leftarrow_{\mathbf{R}} \{0, 1\}^n$ 
35      $\mathcal{U} := \mathcal{U} \cup \{(x_i, i)\}$ 
36   if Compute  $L||R$  (according to the table) then
37     compute  $L||R$ 
38     compute  $S||T := \mathbf{P}(L||R)$ 
39   if Compute  $S||T$  (according to the table) then
40     compute  $S||T$ 
41     compute  $L||R := \mathbf{P}^{-1}(S||T)$ 
42   now all inputs  $(x_1, x_2, \dots, x_6)$  to  $(\mathbf{F}_1, \mathbf{F}_2, \dots, \mathbf{F}_6)$  of the completion of  $(x, y, z)$  are known
43   compute  $x_0 := L, x_7 := T$ 
44   if  $x_j \in \mathbf{F}_j$  or  $x_{j+1} \in \mathbf{F}_{j+1}$  then
45     abort
46   else (adapt according to the table)
47      $\mathbf{F}_j(x_j) := x_{j-1} \oplus x_{j+1}$ 
48      $\mathbf{F}_{j+1}(x_{j+1}) := x_j \oplus x_{j+2}$ 
49      $\mathcal{U} := \mathcal{U} \cup \{(x_j, j), (x_{j+1}, j + 1)\}$ 
50   return  $\mathcal{U}$ 

```

Lines 2 and 3 need further explanation. We assume that the simulator keeps track of the 6-tuples (R, X, Y, Z, A, S) of values that were defined in any COMPLETECHAIN-execution up to the current point of execution. In line 2, COMPLETECHAIN checks whether the values x, y, z for given k, d are part of such a 6-tuple of values that were defined in some earlier COMPLETECHAIN-execution. If so, the empty set is returned. For example, if in CHAINQUERY($R', 1$) we find $(S', A') \in \mathcal{C}(-, R', 1)$, then COMPLETECHAIN($-, R', S', A', 1$) occurs and line 2 checks if there is a 6-tuple (R, X, Y, Z, A, S) from an earlier COMPLETECHAIN-execution where $R = R', S = S'$ and $A = A'$. If so, the chain (S', A') is not completed again and the empty set is returned in line 3 immediately. Note that steps 2 and 3 were not included in the simulator definition in [CPS08b]. But if these steps are not performed, the simulator trivially aborts as soon as a recursive COMPLETECHAIN call occurs in CHAINQUERY. (In the above example of (S', A') , if the values (R', X, Y, Z, A', S') were defined in an earlier COMPLETECHAIN-execution, the simulator would abort at step 29 of COMPLETECHAIN, since both $Y \in \mathbf{F}_3$ and $X \in \mathbf{F}_2$ already.) Furthermore, note that lines 5 to 11 are used to define missing function values for virtual chains.

Fig. 4 illustrates how the simulator \mathbf{S} completes 3-chains.

The XORQUERY procedures. As mentioned earlier, the procedures XORQUERY₁, XORQUERY₂, and XORQUERY₃ perform additional calls to CHAINQUERY *before* the chains for CHAINQUERY(x, k) are completed.

The idea behind XORQUERY₁ is the following: We consider the execution of CHAINQUERY($X, 2$) for some X and in this execution a recursive call to CHAINQUERY($Y, 3$) that occurs for some Y . For CHAINQUERY($Y, 3$), XORQUERY₁ should ensure that for any $(\mathbf{F}_3, +)$ chain (Y, Z, A) , $X := \mathbf{F}_3(Y) \oplus Z$ is not in \mathbf{F}_2 . The same property should be ensured symmetrically for CHAINQUERY($A, 5$).

```

51 procedure XORQUERY1( $x, k$ ):

```

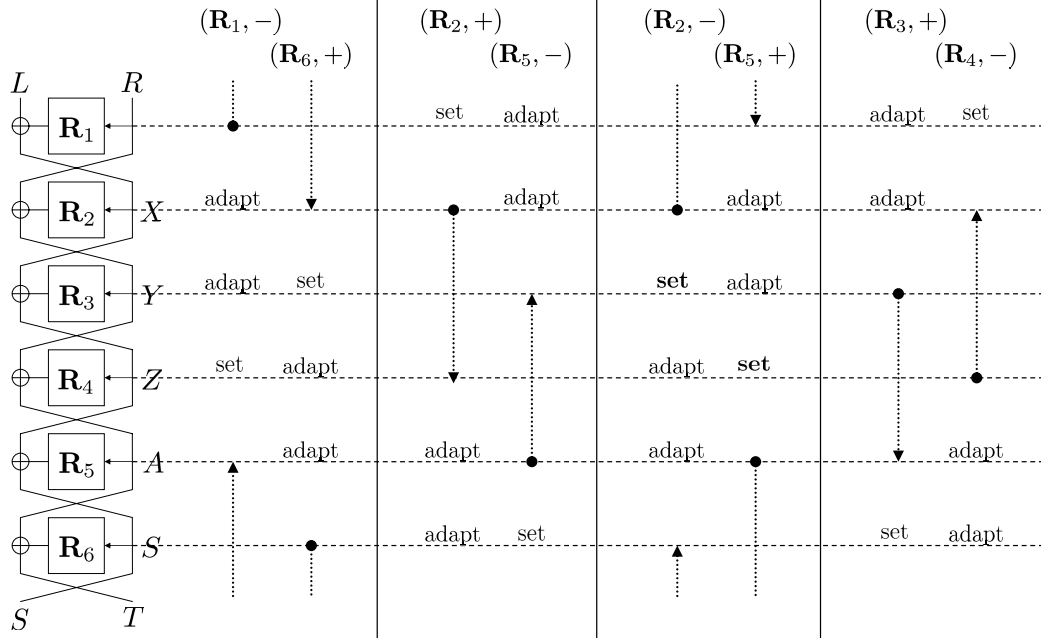

Figure 4: An illustration of how \mathbf{S} completes 3-chains

```

52  if  $k = 5$  then
53     $A' := \{x \oplus R_1 \oplus R_2 \notin \mathbf{F}_5 \mid R_1, R_2 \in \mathbf{F}_1, R_1 \neq R_2\}$ 
54  else if  $k = 1$  then
55     $A' := \{A \oplus x \oplus R_2 \notin \mathbf{F}_5 \mid A \in \mathbf{F}_5, R_2 \in \mathbf{F}_1\}$ 
56  if  $k = 5$  or  $k = 1$  then
57    forall  $A' \in A'$  do
58      if  $\exists R' \in \mathbf{F}_1, \exists S' \in \mathbf{F}_6 : \mathbf{P}^{-1}(S' \parallel \mathbf{F}_6(S') \oplus A')|_2 = R'$  then
59         $\mathbf{F}_5(A') \leftarrow_{\mathbf{R}} \{0, 1\}^n$ 
60        CHAINQUERY( $A', 5$ )
61  if  $k = 2$  then
62     $\mathcal{X}' := \{x \oplus S_1 \oplus S_2 \notin \mathbf{F}_2 \mid S_1, S_2 \in \mathbf{F}_6, S_1 \neq S_2\}$ 
63  else if  $k = 6$  then
64     $\mathcal{X}' := \{X \oplus x \oplus S_2 \notin \mathbf{F}_2 \mid X \in \mathbf{F}_2, S_2 \in \mathbf{F}_6\}$ 
65  if  $k = 2$  or  $k = 6$  then
66    forall  $X' \in \mathcal{X}'$  do
67      if  $\exists S' \in \mathbf{F}_6, \exists R' \in \mathbf{F}_1 : \mathbf{P}(\mathbf{F}_1(R') \oplus X' \parallel R')|_1 = S'$  then
68         $\mathbf{F}_2(X') \leftarrow_{\mathbf{R}} \{0, 1\}^n$ 
69        CHAINQUERY( $X', 2$ )

```

XORQUERY₂ and XORQUERY₃ are used as follows: Consider the execution of CHAINQUERY($Y, 3$) for some Y and in this execution a recursive call to CHAINQUERY($X, 2$). These two procedures should ensure that, under certain assumptions, the simulator does not abort in the next two recursion levels, and after these two levels certain properties hold. The same holds symmetrically for CHAINQUERY($A, 5$) for some A . Again, this is just an intuition and it is not clear at this point if these goals are achievable with XORQUERY₂ and XORQUERY₃.

```

70  procedure XORQUERY2( $x, k$ ):

```

71 $\mathcal{M} := \{(L, R, Z, A, S) | \mathbf{P}^{-1}(S || A \oplus \mathbf{F}_6(S)) = L || R,$
72 $R \notin \mathbf{F}_1,$
73 $A \in \mathbf{F}_5,$
74 $S \in \mathbf{F}_6,$
75 $Z = \mathbf{F}_5(A) \oplus S\}$
76 **forall** $(L, R, Z, A, S) \in \mathcal{M}$ **do**
77 **if** $k = 6$ and $\exists Z' \in \mathbf{F}_4 \setminus \{Z\} : \mathbf{P}(L \oplus Z \oplus Z' || R)|_1 = x$ or
78 $k = 3$ and $\exists S' \in \mathbf{F}_6 : \mathbf{P}(L \oplus x \oplus Z || R)|_1 = S'$ **then**
79 $\mathbf{F}_1(R) \leftarrow_{\mathbf{R}} \{0, 1\}^n$
80 $\text{CHAINQUERY}(R, 1)$
81 $\mathcal{M} := \{(S, T, R, X, Y) | \mathbf{P}(X \oplus \mathbf{F}_1(R) || R) = S || T,$
82 $S \notin \mathbf{F}_5,$
83 $X \in \mathbf{F}_2,$
84 $R \in \mathbf{F}_1,$
85 $Y = \mathbf{F}_2(X) \oplus R\}$
86 **forall** $(S, T, R, X, Y) \in \mathcal{M}$ **do**
87 **if** $k = 1$ and $\exists Y' \in \mathbf{F}_3 \setminus \{Y\} : \mathbf{P}^{-1}(S || T \oplus Y \oplus Y')|_2 = x$ or
88 $k = 4$ and $\exists R' \in \mathbf{F}_1, : \mathbf{P}^{-1}(S || T \oplus x \oplus Y)|_2 = R'$ **then**
89 $\mathbf{F}_6(S) \leftarrow_{\mathbf{R}} \{0, 1\}^n$
90 $\text{CHAINQUERY}(S, 6)$
91
92
93 **procedure** $\text{XORQUERY}_3(x, k):$
94 $\mathcal{R} := \{(Y, R_1, R_2) | \mathbf{P}^{-1}(S_1 || A_1 \oplus \mathbf{F}_6(S_1)) = L_1 || R_1,$
95 $\mathbf{P}^{-1}(S_2 || A_2 \oplus \mathbf{F}_6(S_2)) = L_2 || R_2,$
96 $Y \notin \mathbf{F}_3,$
97 $S_1 \in \mathbf{F}_6$
98 $Z_1 = \mathbf{F}_5(A_1) \oplus S_1, Z_1 \in \mathbf{F}_4,$
99 $A_1 = \mathbf{F}_4(Z_1) \oplus Y, A_1 \in \mathbf{F}_5$
100 $S_2 \in \mathbf{F}_6$
101 $Z_2 = \mathbf{F}_5(A_2) \oplus S_2, Z_2 \in \mathbf{F}_4,$
102 $A_2 = \mathbf{F}_4(Z_2) \oplus Y, A_2 \in \mathbf{F}_5\}$
103 **if** $k = 3$ and $\exists (Y, R_1, R_2) \in \mathcal{R} : Y = x \oplus R_1 \oplus R_2$ **then**
104 $\mathbf{F}_3(Y) \leftarrow_{\mathbf{R}} \{0, 1\}^n$
105 $\text{CHAINQUERY}(Y, 3)$
106 $\mathcal{S} := \{(Z, S_1, S_2) | \mathbf{P}(\mathbf{F}_1(R_1) \oplus X_1 || R_1) = S_1 || T_1,$
107 $\mathbf{P}(\mathbf{F}_1(R_2) \oplus X_2 || R_2) = S_2 || T_2,$
108 $Z \notin \mathbf{F}_4,$
109 $R_1 \in \mathbf{F}_1$
110 $Y_1 = \mathbf{F}_2(X_1) \oplus R_1, Y_1 \in \mathbf{F}_3,$
111 $X_1 = \mathbf{F}_3(Y_1) \oplus Z, X_1 \in \mathbf{F}_2$
112 $R_2 \in \mathbf{F}_1$
113 $Y_2 = \mathbf{F}_2(X_2) \oplus R_2, Y_2 \in \mathbf{F}_3,$
114 $X_2 = \mathbf{F}_3(Y_2) \oplus Z, X_2 \in \mathbf{F}_2\}$
115 **if** $k = 4$ and $\exists (Z, S_1, S_2) \in \mathcal{S} : Z = x \oplus S_1 \oplus S_2$ **then**
116 $\mathbf{F}_4(Z) \leftarrow_{\mathbf{R}} \{0, 1\}^n$
117 $\text{CHAINQUERY}(Z, 4)$

Illustrations describing the XORQUERY procedures. We provide illustrations to better describe procedures XORQUERY₁, XORQUERY₂, and XORQUERY₃.

Fig. 5 illustrates how XORQUERY₁ works. In the figure, the values that are required to be in the history are marked with boxes, and the value x that XORQUERY₁ is called upon is marked with a circle. We abbreviate CHAINQUERY by CQ.

For example, the left upper quarter of Fig. 5 describes calls to XORQUERY₁($A, 5$) for some A . Upon such a call, \mathbf{S} computes the values A' for any pairs R_1, R_2 in \mathbf{F}_1 where $R_1 \neq R_2$. Now if some A' is not in \mathbf{F}_5 (in the figure, there is no box around A'), then \mathbf{S} checks if there is a 3-chain (A', S', R') for some $S' \in \mathbf{F}_6$ and $R' \in \mathbf{F}_1$ (in the figure, there are boxes around these values). If such a chain is found, \mathbf{S} calls CHAINQUERY($A', 5$). In the figure, we write XORQUERY₁($A, 5$) \rightarrow CQ($A', 5$) to say this.

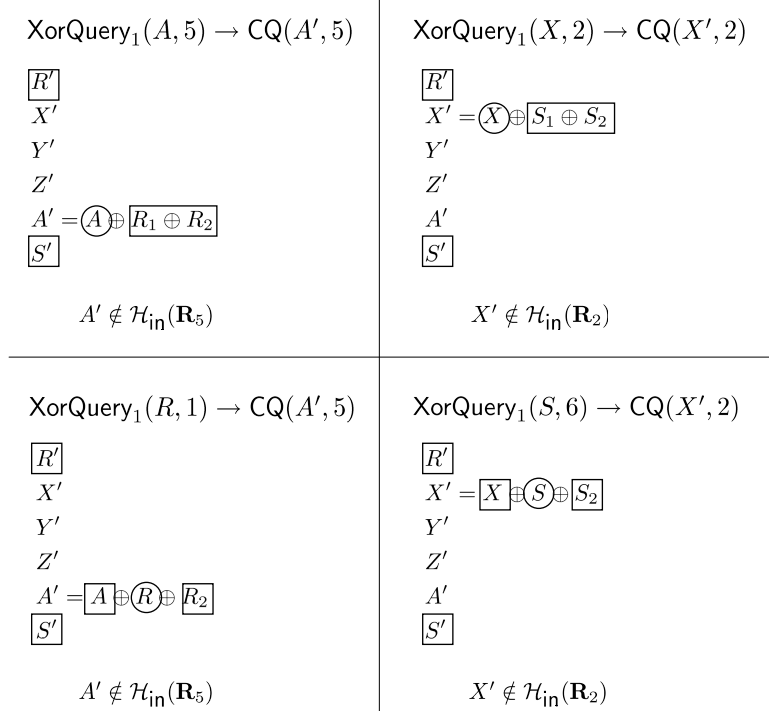

Figure 5: An illustration for XORQUERY₁

Fig. 6 provides an illustration of XORQUERY₂. The notation is the same as in the illustration for XORQUERY₁.

For XORQUERY₃ we provide Fig. 7 to facilitate the understanding.

Here is a description of XORQUERY₃ for the case of $k = 3$: Upon query ($x, 3$) where $x = \bar{Y}$ the procedure sets $\mathbf{F}_3(Y) \leftarrow_{\mathbf{R}} \{0, 1\}^n$ and calls CHAINQUERY($Y, 3$) for any $Y \notin \mathbf{F}_3$ if there are 3-chains (Z_1, A_1, S_1) and (Z_2, A_2, S_2) (as in the figure) in the history and the corresponding R_1 and R_2 are such that $\bar{Y} = Y \oplus R_1 \oplus R_2$.

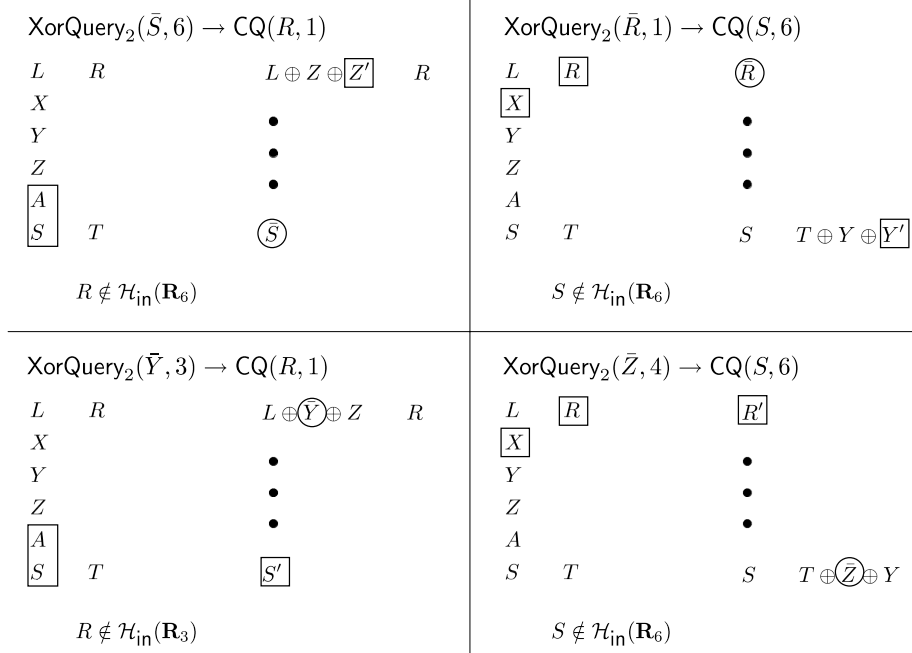

Figure 6: An illustration for XORQUERY₂

B Detailed Analysis of the Attack against the Simulator of Coron et al.

Formally, the distinguisher \mathbf{D} is defined as follows. (The distinguisher's output bit is irrelevant, since its goal is to let the simulator abort.)

- 1 **Distinguisher \mathbf{D}**
- 2 $X \leftarrow_R \{0, 1\}^n, R_2 \leftarrow_R \{0, 1\}^n, R_3 \leftarrow_R \{0, 1\}^n$
- 3 $L_2 := \mathbf{F}_1(R_2) \oplus X, L_3 := \mathbf{F}_1(R_3) \oplus X$
- 4 $S_2 \| T_2 := \mathbf{P}(L_2 \| R_2), S_3 \| T_3 := \mathbf{P}(L_3 \| R_3)$
- 5 $A_2 := \mathbf{F}_6(S_2) \oplus T_2, A_3 := \mathbf{F}_6(S_3) \oplus T_3$
- 6 $R_1 := R_2 \oplus A_2 \oplus A_3$
- 7 $L_1 := \mathbf{F}_1(R_1) \oplus X$
- 8 $S_1 \| T_1 := \mathbf{P}(L_1 \| R_1)$
- 9 $A_1 := \mathbf{F}_6(S_1) \oplus T_1$
- 10 $\bar{A} := A_1 \oplus R_1 \oplus R_2$
- 11 query $\mathbf{F}_5(\bar{A})$

Implementing \mathbf{P} . The distinguisher makes $7 < 2^3$ queries to \mathbf{F} and three permutation queries. Assume without loss of generality that at most $B := 2^{50}$ queries are made to the permutation \mathbf{P} (or its inverse \mathbf{P}^{-1}) by the simulator or by the distinguisher. Once more than B \mathbf{P} queries are made, we assume that the simulator \mathbf{S} aborts. By Lemma 1 in [CPS08b], the probability that abort occurs in the original experiment (where no limit on the number of \mathbf{P} queries made by the simulator is imposed) is at most $2^{55}/2^n = \mathcal{O}(2^{-n})$ lower than in the version where the query number is bounded by B . Note that, while large, B is constant, and although it could be made significantly smaller for the purposes of this section, we use the larger value to rely on the analysis of [CPS08b].

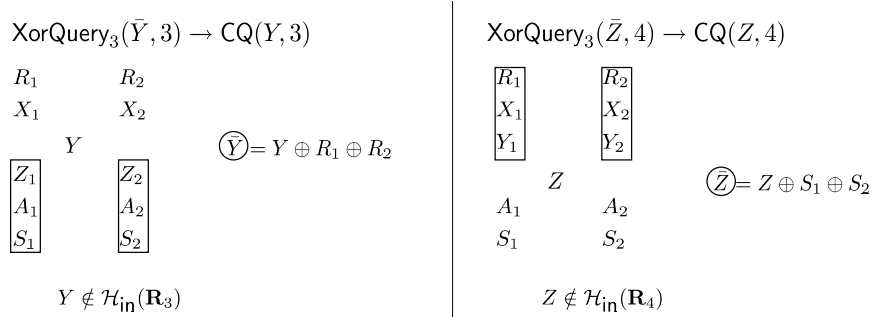

Figure 7: An illustration for XORQUERY₃

It is convenient to think of \mathbf{P} as being implemented as follows: Initially, two lists \mathcal{L}_\downarrow and \mathcal{L}_\uparrow of B uniformly distributed, but distinct, $2n$ -bit values are generated. Then, each time a \mathbf{P} query is issued with input x , we first check if $\mathbf{P}(x)$ is defined (in which case we simply return the previously defined value), or if $\mathbf{P}^{-1}(y) = x$ (in which case we return y .) Otherwise, we assign to $\mathbf{P}(x)$ the first value y in \mathcal{L}_\downarrow such that $\mathbf{P}^{-1}(y)$ is undefined, and let $\mathbf{P}^{-1}(y) := x$. Also, \mathbf{P}^{-1} queries are answered symmetrically. It is not hard to verify that this gives rise to a uniform random permutation as long as at most B queries are made: Each forward query $\mathbf{P}(x)$ assigns a value from \mathcal{L}_\downarrow which is uniformly distributed among all values for which $\mathbf{P}^{-1}(y)$ is not defined, and, if $x \in \mathcal{L}_\uparrow$, ensures that $x \in \mathcal{L}_\downarrow$ cannot be used as an answer to a query to \mathbf{P}^{-1} .

For simplicity, denote as \mathcal{L}_1 and \mathcal{L}_2 the lists containing the first and second halves, respectively, of the elements of $\mathcal{L} := \mathcal{L}_\downarrow \parallel \mathcal{L}_\uparrow$. (Here, \parallel denotes list concatenation.)

Initialization. We consider the interaction of \mathbf{D} and \mathbf{S} , and show that the latter aborts with overwhelming probability. Before executing Line 11, it is clear that no additional $\mathbf{F}_i(x)$ entry is defined by one of the XORQUERY calls, since only XORQUERY₁ and XORQUERY₂ can be called when answering queries to either of \mathbf{F}_1 or \mathbf{F}_6 , but the histories of $\mathbf{F}_2, \mathbf{F}_3, \mathbf{F}_4, \mathbf{F}_5$ are all empty. Thus when $\mathbf{F}_5(\bar{A})$ is called, only the values $R_1, R_2, R_3, S_1, S_2, S_3$ are in the history of \mathbf{S} , and consequently, no 3-chain exists so far. Also, the first three elements of \mathcal{L} are $S_1 \parallel T_1, S_2 \parallel T_2$, and $S_3 \parallel T_3$.

The following definitions introduce bad events: Their definition is tailored at what is needed later, and may appear confusing at first. (We invite the reader to skip their definition, and come back later.)

Definition B.1. The event $\text{Bad}_{\mathbf{P}}$ occurs if one of the following is true:

- (i) There exists a collision among the first or second halves of the elements of \mathcal{L} ;
- (ii) $\mathcal{L}_2 \cap \{R_1, R_2, R_3\} \neq \emptyset$, that is, the second half of some element of \mathcal{L} is in $\{R_1, R_2, R_3\}$;
- (iii) There exists $R, R' \in \mathcal{L}_2$ such that $R_1 \oplus R_2 = R \oplus R'$.

◇

Definition B.2. The event Bad_1 occurs if one of the following is true:

- (i) Two elements among R_1, R_2, R_3 collide;
- (ii) $A \oplus \mathbf{F}_6(S) \in \mathcal{L}_2$ for $(A, S) \in (\mathbf{F}_5 \cup \{\bar{A}\}) \times \mathbf{F}_6 \setminus \{(A_i, S_i) \mid i = 1, 2, 3\}$;

- (iii) There exists $(i, j) \in \{(1, 3), (2, 3)\}$ and $k \in \{1, 2, 3\}$ such that for $A' := \bar{A} \oplus R_i \oplus R_j \notin \mathbf{F}_5$ we have $\mathbf{F}_6(S_k) \oplus A' \in \mathcal{L}_2$;
- (iv) There exist $i, j, k, \ell \in \{1, 2, 3\}$, $i \neq j$, such that for $A'' := A_\ell \oplus R_i \oplus R_j \notin \mathbf{F}_5$ we have $\mathbf{F}_6(S_k) \oplus A'' \in \mathcal{L}_2$;
- (v) $R_i \oplus R_j \oplus A_j \oplus A = 0^n$ for $i \neq j$, $A \in \{\bar{A}, A_1, A_2, A_3\}$, and $(i, j, A) \notin \{(i, i, A_i) \mid i = 1, 2, 3\} \cup \{(1, 2, A_3), (2, 1, \bar{A})\}$.

◇

The following two lemmas upper bound the probability of these events occurring.

Lemma B.3. $\Pr[\text{Bad}_{\mathbf{P}}] = \mathcal{O}(B^2 \cdot 2^{-n})$.

Proof. For (i), note that for any two $i, j \in \{1, \dots, 2B\}$, $i \neq j$, and $h \in \{1, 2\}$,

$$\Pr[V_i|_h = V_j|_h] = 2^n \cdot \frac{2^n \cdot (2^n - 1)}{2^{2n} \cdot (2^{2n} - 1)} = \mathcal{O}(2^{-n})$$

and $\Pr[V_i|_h \in \{R_1, R_2, R_3\}] \leq 3 \cdot 2^{-n}$. The bound follows by the union bound. Finally, an upper bound of the probability of (iii) is $B^2 \cdot 2^n \frac{2^n \cdot (2^n - 1)}{2^{2n} \cdot (2^{2n} - 1)} = \mathcal{O}(B^2 \cdot 2^{-n})$. □

Lemma B.4. $\Pr[\text{Bad}_1] = \mathcal{O}(B \cdot 2^{-n})$.

Proof. For (i), we observe that the random variable R_1 is uniform and independent of R_2 and R_3 , since A_2 and A_3 are independent of R_2 and R_3 due to $\mathbf{F}_6(S_2)$ and $\mathbf{F}_6(S_3)$ being chosen uniformly and independently. Thus, the probability that $R_1 = R_2$, $R_2 = R_3$ or $R_1 = R_3$ is at most $3 \cdot 2^{-n}$.

It is also easy to verify that the value $T' := A \oplus \mathbf{F}_6(S)$ is uniformly distributed and independent of \mathcal{L} for $(A, S) \in (\mathbf{F}_5 \cup \{\bar{A}\}) \times \mathbf{F}_6 \setminus \{(A_i, S_i) \mid i = 1, 2, 3\}$, and therefore $T' \in \mathcal{L}_2$ holds with probability at most $2B \cdot 2^{-n}$; an upper bound on the probability of (ii) follows by the union bound.

To bound (iii), we use the fact that for all $(i, j) \in \{(1, 3), (2, 3)\}$ and $k \in \{1, 2, 3\}$ the value $T' := \mathbf{F}_6(S_k) \oplus A'$ equals

$$\mathbf{F}_6(S_k) \oplus \mathbf{F}_6(S_1) \oplus T_1 \oplus R_1 \oplus R_2 \oplus R_i \oplus R_j$$

and is hence uniformly distributed and independent of \mathcal{L} . Therefore, (iii) occurs with probability at most $2B \cdot 2^{-n}$. Similarly, to bound (iv), we observe that for all $i \neq j$, and $k, \ell \in \{1, 2, 3\}$ the value $T'' := \mathbf{F}_6(S_k) \oplus A''$ equals

$$\mathbf{F}_6(S_k) \oplus \mathbf{F}_6(S_\ell) \oplus T_\ell \oplus R_i \oplus R_j$$

and is therefore uniformly distributed, and independent of \mathcal{L} .

In (v) we see that in all cases, substituting \bar{A} with $A_1 \oplus R_1 \oplus R_2$, A_i with $\mathbf{F}_6(S_i) \oplus T_i$, and R_1 with $R_2 \oplus A_2 \oplus A_3$, we end up in one of the following two cases: Either the given sum still contains at least one term which is uniformly distributed and independent of the other terms, and thus the sum equals 0^n with probability 2^{-n} . Or, the resulting equation is $R_2 = R_3$, which does not hold by the choice of these values by **D**. The actual bound follows by a union bound over all possible combinations. □

From now on, the analysis assumes that neither of $\text{Bad}_{\mathbf{P}}$ and Bad_1 has occurred. Before we proceed in analyzing the rest of the execution, we prove the following lemmas, which will be useful to simplify the analysis below, and rely on the assumptions that the above events do not occur.

Lemma B.5. *As long as $\mathbf{F}_1 = \{R_1, R_2, R_3\}$ and $\mathbf{F}_6 = \{S_1, S_2, S_3\}$, no $\text{XORQUERY}_1(A_i, 5)$ (for $i = 1, 2, 3$) call results in a recursive CHAINQUERY call.*

Proof. For the **if** statement within $\text{XORQUERY}_1(A_i, 5)$ call to be satisfied, there must exist $A'' = A_i \oplus R_i \oplus R_j$ such that $R_i \neq R_j$ and $\mathbf{P}^{-1}(S' \parallel \mathbf{F}(S') \oplus A'')|_2 \in \{R_1, R_2, R_3\}$, where $S' \in \{S_1, S_2, S_3\}$. However, since $\mathbf{F}(S') \oplus A'' \notin \mathcal{L}_2$, as this implies Bad_1 , we need to have $\mathbf{P}^{-1}(S' \parallel \mathbf{F}_6(S') \oplus A'') \in \mathcal{L}$. But then, since $\mathbf{P}^{-1}(S' \parallel \mathbf{F}(S') \oplus A'')|_2 \in \{R_1, R_2, R_3\}$, we also have $\text{Bad}_{\mathbf{P}}$. \square

Lemma B.6. *Assume that $\mathbf{F}_1 = \{R_1, R_2, R_3\}$ and $\mathbf{F}_6 = \{S_1, S_2, S_3\}$. Then, as long as $\text{Bad}_{\mathbf{P}}$ holds, a call to $\text{XORQUERY}_2(x, k)$ for $k \in \{3, 4\}$ and $x \notin \mathbf{F}_{7-k}$ does not set any new values and does not make any new recursive CHAINQUERY calls.*

Proof. Let $k = 3$ and consider a tuple $(L, R, Z, A, S) \in \mathcal{M}$: This means that querying \mathbf{P}^{-1} on input $S \parallel \mathbf{F}_6(S) \oplus A$ (with $S = S_i$ for some $i \in \{1, 2, 3\}$) returns a pair $L \parallel R$ with $R \notin \{R_1, R_2, R_3\}$. This in particular means that $A \neq A_i$ (as otherwise $R = R_i$), and also that $L \parallel R \in \mathcal{L}$, as otherwise $S_i \parallel \mathbf{F}_6(S_i) \oplus A \in \mathcal{L}$, and (ii) for Bad_1 would have occurred. However, if the **if** statement is satisfied, this also means that $\mathbf{P}(L \oplus x \oplus Z \parallel R)|_1 = S' \in \{S_1, S_2, S_3\}$. But since $\text{Bad}_{\mathbf{P}}$ has not happened, this means that there has been a previous \mathbf{P}^{-1} query with input $S' \parallel T'$ which has returned $L \oplus x \oplus Z \parallel R \in \mathcal{L}$. Yet, since $L \oplus x \oplus Z \neq L$ (due to $x \neq Z$, as otherwise $x \in \mathbf{F}_4$), this also means that there has been a collision on the second half, and $\text{Bad}_{\mathbf{P}}$ has occurred.

The case for $k = 4$ is fully symmetric. \square

Added complexity in the execution of \mathbf{S} stems from the fact that it tests for so-called “virtual chains”, and we want to argue that they do not play a role in the upcoming analysis of the attack. First, note that as long as \mathbf{F}_2 contains at most one element (this is the case for most of the attack), $\mathbf{F}_6^* = \mathbf{F}_6$. Additionally, when calling $\text{CHAINQUERY}(A, 5)$ for $A \in \{\bar{A}, A_1, A_2, A_3\}$, in order for $\mathbf{F}_1 \neq \mathbf{F}_1^*$ to occur, we need that there exist $(A, S), (A', S') \in \{\bar{A}, A_1, A_2, A_3\} \times \{S_1, S_2, S_3\}$ such that $A \neq A'$ and $\mathbf{P}^{-1}(S \parallel \mathbf{F}_6(S) \oplus A)|_2 = \mathbf{P}^{-1}(S' \parallel \mathbf{F}_6(S') \oplus A')$. It is not hard to verify that any possible case implies $\text{Bad}_{\mathbf{P}}$ or Bad_1 , and hence we can safely ignore virtual chains in the following. (We will indeed need to ignore virtual chains only for as long as the conditions needed for these arguments hold.)

First phase of the simulator’s execution. From now on, we continue the analysis of the execution under the assumption that Bad_1 , and $\text{Bad}_{\mathbf{P}}$ have not occurred. Upon querying $\mathbf{F}_5(\bar{A})$, the simulator sets $\mathbf{F}_5(\bar{A}) \leftarrow_{\mathbf{R}} \{0, 1\}^n$ and then first executes $\text{XORQUERY}_1(\bar{A}, 5)$: Note that $A_1 = \bar{A} \oplus R_1 \oplus R_2 \notin \mathbf{F}_5$ (since, at this point, the history of \mathbf{F}_5 is empty), and A_1 satisfies the **if** statement (with $S' = S_1$ and $R' = R_1$) so that $\mathbf{F}_5(A_1) \leftarrow_{\mathbf{R}} \{0, 1\}^n$ is set and $\text{CHAINQUERY}(A_1, 5)$ is called. Also, no other CHAINQUERY call occurs, as if the condition in the **if** statement is true for some other value, then since (ii) in the definition of Bad_1 does not occur, this means that, for some input x , $\mathbf{P}(x)$ has been assigned a value from \mathcal{L} whose second half is in $\{R_1, R_2, R_3\}$, which implies $\text{Bad}_{\mathbf{P}}$.

Moreover, in the subsequent execution of $\text{CHAINQUERY}(A_1, 5)$ the procedure XORQUERY_1 also does not invoke CHAINQUERY by Lemma B.5. Moreover, $\mathcal{C}(+, A_1, 5) = \{(S_1, R_1)\}$, since (A_1, S_i, R_j) for $(i, j) \neq (1, 1)$ cannot constitute a chain, as this would either imply (i) in the definition of Bad_1 or the fact that $\text{Bad}_{\mathbf{P}}$ occurs. Also, $\mathcal{C}(-, A_1, 5) = \emptyset$, since no \mathbf{F}_3 and \mathbf{F}_4 values have been defined so far. Therefore, $(S_1, R_1) \in \mathcal{C}(+, A_1, 5)$ is found and gets completed by COMPLETECHAIN to the tuple $(R_1, X, Y_1, Z_1, A_1, S_1)$, by defining

$$\begin{aligned} X &:= \mathbf{F}_1(R_1) \oplus L_1, & Z_1 &:= \mathbf{F}_5(A_1) \oplus S_1, & \mathbf{F}_4(Z_1) &\leftarrow_{\mathbf{R}} \{0, 1\}^n, \\ Y_1 &:= \mathbf{F}_4(Z_1) \oplus A_1, & \mathbf{F}_2(X) &:= R_1 \oplus Y_1, & \mathbf{F}_3(Y_1) &:= Z_1 \oplus X. \end{aligned}$$

We consider the following event defined on these new values.

Definition B.7. The event Bad_2 occurs if one of the following holds:

- (i) $Y_1 = Z_1$;
- (ii) $Y_1 = Z_1 \oplus R_1 \oplus R$ where $R \in \{R_2, R_3\}$;
- (iii) $Z_1 \oplus \mathbf{F}_5(\bar{A}) \in \mathcal{L}_1$;
- (iv) $Z_1 \oplus \mathbf{F}_5(\bar{A}) = S_1$.

◇

Lemma B.8. $\Pr[\text{Bad}_2] = \mathcal{O}(B \cdot 2^{-n})$

Proof. For (i) and (ii), since Y_1 is uniform and independent of Z_1 , R_1 , and R_2 by the fact that $\mathbf{F}_5(Y_1)$ is set uniformly, the values on both sides are equal with probability 2^{-n} . Furthermore, both $\mathbf{F}_5(\bar{A})$ and $\mathbf{F}_5(A_1)$ are set uniformly (since $A_1 \neq \bar{A}$ by Bad_1 not occurring), and thus $Z_1 \oplus \mathbf{F}_5(\bar{A}) = S_1 \oplus \mathbf{F}_5(A_1) \oplus \mathbf{F}_5(\bar{A})$ is uniform and independent of \mathcal{L}_1 , and is thus in the set with probability at most $2B \cdot 2^{-n}$ by the union bound. Similarly, we show that (iv) occurs with probability 2^{-n} only. □

Second phase of the simulator's execution. Subsequently, the simulator schedules calls, in arbitrary¹⁵ order, to $\text{CHAINQUERY}(X, 2)$, $\text{CHAINQUERY}(Y_1, 3)$ and $\text{CHAINQUERY}(Z_1, 3)$.

Lemma B.9. *No CHAINQUERY invocation preceding the invocation of $\text{CHAINQUERY}(X, 2)$ issues a recursive CHAINQUERY call. Furthermore, $\text{XORQUERY}_1(X, 2)$ within $\text{CHAINQUERY}(X, 2)$ also does not trigger a CHAINQUERY invocation.*

Proof. Assume that $\text{CHAINQUERY}(X, 2)$ has not been invoked yet. Calls to XORQUERY_2 cannot invoke CHAINQUERY recursively by Lemma B.6 and the fact that $Y_1 \neq Z_1$ (using Bad_2). Also note that $\text{XORQUERY}_3(Y_1, 3)$ cannot produce recursive CHAINQUERY calls: Note that $A_1 \neq \bar{A}$ (equality implies (i) in Bad_1), and therefore any triple $(Y, R, R') \in \mathcal{R}$ must satisfy $R = R'$ and $Y \notin \mathbf{F}_3$. But then, we cannot have $Y_1 = Y \in \mathbf{F}_3$, and thus the **if** statement is never satisfied. Similarly, the fact that $\text{XORQUERY}_3(Z_1, 4)$ does not invoke CHAINQUERY follows from the fact that both \mathbf{F}_3 and \mathbf{F}_2 only contain one single element.

For both possible CHAINQUERY calls, it also clear that no additional 3-chains to be completed are found. Namely, within $\text{CHAINQUERY}(Y_1, 3)$, only the chains (R_1, X, Y_1) and (Y_1, Z_1, A_1) are possible, and both have been completed. Moreover, when running $\text{CHAINQUERY}(Z_1, 4)$, the 3-chain (X, Y_1, Z_1) has also already been completed, whereas no chain (Z_1, \bar{A}, S_1) exists, as this would yield Bad_2 .

Finally, when $\text{CHAINQUERY}(X, 2)$ is invoked, we also observe that if the **if** statement in the execution of $\text{XORQUERY}_1(X, 2)$ cannot be true: It would imply that there exists $X' \neq X$ such that $\mathbf{P}(X' \oplus \mathbf{F}_1(R_i) \| R_i)_1 \in \{S_1, S_2, S_3\}$, but since $\mathbf{F}_2(X') \oplus R_i \neq L_i$, this implies Bad_P (i). □

We hence can consider the execution of $\text{CHAINQUERY}(X, 2)$, as any previous CHAINQUERY invocation does not affect the history of the simulated round functions. First, note that $\mathcal{C}(-, X, 2) =$

¹⁵In particular, we do not want to make any assumption on the order in which they are called. Of course, it is easier to provide a proof if a certain processing order is assumed, and this would suffice to give a strong argument against \mathbf{S} . Still, we opt for showing the strongest statement.

$\{(R_2, S_2), (R_3, S_3)\}$ and $\mathcal{C}(+, X, 2) = \{(Y_1, Z_1)\}$. The latter chain was already completed, therefore both negative chains are completed, by defining values

$$\begin{aligned} Y_2 &:= \mathbf{F}_2(X) \oplus R_2, & \mathbf{F}_3(Y_2) &\leftarrow_R \{0, 1\}^n, & Z_2 &:= X \oplus \mathbf{F}_3(Y_2), \\ \mathbf{F}_4(Z_2) &:= Y_2 \oplus A_2, & \mathbf{F}_5(A_2) &:= Z_2 \oplus S_2, \end{aligned}$$

as well as

$$\begin{aligned} Y_3 &:= \mathbf{F}_2(X) \oplus R_3, & \mathbf{F}_3(Y_3) &\leftarrow_R \{0, 1\}^n, & Z_3 &:= X \oplus \mathbf{F}_3(Y_3), \\ \mathbf{F}_4(Z_3) &:= Y_3 \oplus A_3, & \mathbf{F}_5(A_3) &:= Z_3 \oplus S_3. \end{aligned}$$

In addition, let us introduce the last bad event in this analysis, defined on the newly defined values.

Definition B.10. The event Bad_3 occurs if one of the following holds:

- (i) $\mathbf{F}_3 \cap \mathbf{F}_4 \neq \emptyset$;
- (ii) $Z \oplus \mathbf{F}_5(A) \in \mathcal{L}_1$ for $(Z, A) \in \mathbf{F}_4 \times \mathbf{F}_5 \setminus \{(Z_i, A_i) \mid i = 1, 2, 3\}$.

◇

Lemma B.11. $\Pr[\text{Bad}_3] \leq \mathcal{O}(2^{-n})$

Proof. For (i), note that the value of Z_i is independent of the value of Y_1, Y_2, Y_3 for $i = 2, 3$, and thus equality only occurs with negligible probability. (Recall that we already assume that $Y_1 \neq Z_1$). Moreover, the case that Z_1 equals Y_2 or Y_3 is would already imply Bad_2 : This is because we would have, for $i = 2, 3$,

$$Z_1 = Y_i = \mathbf{F}_2(X) \oplus R_i = R_1 \oplus Y_1 \oplus R_i.$$

For (ii), we claim that $Z \oplus \mathbf{F}_5(A)$ is always uniform and independent of \mathcal{L} when it is defined. If $Z = Z_1$, then note that $\mathbf{F}_5(\bar{A})$ is set uniformly and independently of Z_1 and \mathcal{L}_1 , whereas $\mathbf{F}_5(A_i) = X \oplus \mathbf{F}_2(Y_i) \oplus S_i$ for $i = 2, 3$, where $\mathbf{F}_2(Y_i)$ is set independently and uniformly. If $Z = Z_i$ for $i = 2, 3$, then note that $\mathbf{F}_5(A_1)$ and $\mathbf{F}_5(\bar{A})$ are set uniformly, whereas by the above $\mathbf{F}_5(A_{5-i})$ is also independent and uniform. □

Final phase of the simulator's execution. From now on, $\text{CHAINQUERY}(Y_i, 3)$, $\text{CHAINQUERY}(Z_i, 4)$ and $\text{CHAINQUERY}(A_i, 5)$ for $i = 2, 3$ are called, in any order.¹⁶ The crucial point is reached as soon as one of $\text{CHAINQUERY}(Y_2, 3)$ or $\text{CHAINQUERY}(A_3, 5)$ is invoked. However, we need to show that all calls preceding one of these calls do not start recursions or set additional function values. First, however, we show that no other chains occur, other than those we expect.

Lemma B.12. *Only the 3-chains (Y_i, Z_i, A_i) for $i = 1, 2, 3$, (Y_1, Z_2, A_3) and (Y_2, Z_1, \bar{A}) exist in $\mathbf{F}_3 \times \mathbf{F}_4 \times \mathbf{F}_5$. Moreover, only the three 3-chains (Z_i, A_i, S_i) for $i = 1, 2, 3$ exist in $\mathbf{F}_4 \times \mathbf{F}_5 \times \mathbf{F}_6$.*

Proof. Such a chain (Y_i, Z_j, A) implies

$$\begin{aligned} Y_i \oplus \mathbf{F}_4(Z_j) \oplus A &= R_i \oplus \mathbf{F}_2(X) \oplus \mathbf{F}_4(Z_j) \oplus A = R_i \oplus \mathbf{F}_2(X) \oplus Y_j \oplus A_j \oplus A \\ &= R_i \oplus R_j \oplus A_j \oplus A = 0^n, \end{aligned}$$

and hence Bad_1 . The second part of the statement follows from Bad_3 not occurring and the fact that $S_1, S_2, S_3 \in \mathcal{L}_1$. □

¹⁶Once again, we dispense with any assumption on the execution order adopted by the simulator.

Lemma B.13. *No CHAINQUERY call preceding the invocation of both CHAINQUERY($Y_2, 3$) and CHAINQUERY($A_3, 5$) provokes a recursive CHAINQUERY call. Also, no XORQUERY within the execution of CHAINQUERY($Y_2, 3$) and CHAINQUERY($A_3, 5$) (whichever is executed first) provokes a recursive CHAINQUERY call.*

Proof. We know, by Lemma B.6 and item (i) in the definition of Bad_3 not taking place, that calls to $\text{XORQUERY}_2(Y_3, 3)$, $\text{XORQUERY}_2(Z_i, 4)$ for $i = 1, 2$ do not provoke any recursive CHAINQUERY calls. Furthermore, $\text{XORQUERY}_3(Y_3, 3)$ cannot invoke CHAINQUERY, as by Lemma B.12, the fact that only the three chains (Z_i, A_i, S_i) for $i = 1, 2, 3$ exist in $\mathbf{F}_4 \times \mathbf{F}_5 \times \mathbf{F}_6$, the set \mathcal{R} must be empty. Also, $\text{XORQUERY}_3(Z_i, 4)$ cannot invoke CHAINQUERY by the fact that X is the only element of \mathbf{F}_2 .

In addition, none of these CHAINQUERY invokes COMPLETECHAIN because of Lemma B.12.

The fact that $\text{XORQUERY}_1(A_2, 5)$ in CHAINQUERY($A_2, 5$) does not make any CHAINQUERY calls is implied by Lemma B.5, whereas if CHAINQUERY($Y_2, 3$) is invoked first, then $\text{XORQUERY}_2(Y_2, 3)$ does not invoke CHAINQUERY by Lemma B.6, whereas $\text{XORQUERY}_3(Y_2, 3)$ does not invoke CHAINQUERY because of Lemma B.12 as above. \square

Finally, we can distinguish two cases:

- (1) CHAINQUERY($Y_2, 3$) is invoked first. As shown above, no XORQUERY call calls CHAINQUERY recursively. Then, \mathbf{S} now finds and completes the chain $(Z_1, \bar{A}) \in \mathcal{C}(+, Y_2, 3)$. No other chains are found by Lemma B.12.

The following values are set:

$$\begin{aligned} X' &:= \mathbf{F}_3(Y_2) \oplus Z_1, & S_4 &:= \mathbf{F}_5(\bar{A}) \oplus Z_1, \\ \mathbf{F}_6(S_4) &\leftarrow_{\mathbf{R}} \{0, 1\}^n, & L_4 \parallel R_4 &:= \mathbf{P}^{-1}(S_4 \parallel \mathbf{F}_6(S_4) \oplus \bar{A}) \\ \mathbf{F}_1(R_4) &:= L_4 \oplus X', & \mathbf{F}_2(X') &:= Y_2 \oplus R_4. \end{aligned}$$

In particular, note that since $S_4 \notin \mathcal{L}_1$ (since Bad_3 (ii) does not occur), then $R_4 \in \mathcal{L}_2$. But then $R_5 := \mathbf{F}_2(X') \oplus Y_1 \notin \mathcal{L}_2$, as otherwise this would imply that $\text{Bad}_{\mathbf{P}}$ (iii) occurs, since

$$R_5 = Y_2 \oplus R_4 \oplus Y_1 = \mathbf{F}_2(X) \oplus R_2 \oplus R_4 \oplus Y_1 = R_1 \oplus R_2 \oplus R_4.$$

Recall that we assume that $S_5 = \mathbf{F}_5(A_3) \oplus Z_2 \notin \mathcal{L}_1$, as this yields Bad_3 (ii). But then, at some point (the latest at the invocation of CHAINQUERY($X', 2$)) the chain going through X' , Y_1 , Z_2 , and A_3 needs to be completed. However, no completion is possible, because $R_5 \notin \mathcal{L}_2$ and $S_5 \notin \mathcal{L}_1$ (by Bad_3 (ii)). In fact, this holds *regardless* of which strategy the simulator employs to complete the chain, and in this concrete case, this is reflected by an abort.

- (2) CHAINQUERY($A_3, 5$) is invoked first. The argument is symmetric. First, by Lemma B.13, no XORQUERY calls trigger CHAINQUERY invocations, and \mathbf{S} now finds and completes the chain $(Y_1, Z_2) \in \mathcal{C}(-, A_3, 5)$, and no other chains are found by Lemma B.12. This in particular means that the following values are set

$$\begin{aligned} X' &:= \mathbf{F}_3(Y_1) \oplus Z_2, & S_5 &:= \mathbf{F}_5(A_3) \oplus Z_2, \\ \mathbf{F}_6(S_5) &\leftarrow_{\mathbf{R}} \{0, 1\}^n, & L_5 \parallel R_5 &:= \mathbf{P}^{-1}(S_5 \parallel \mathbf{F}_6(S_5) \oplus A_3) \\ \mathbf{F}_1(R_4) &:= L_5 \oplus X', & \mathbf{F}_2(X') &:= Y_1 \oplus R_5. \end{aligned}$$

Once again, we have that $R_4 := \mathbf{F}_2(X') \oplus Y_2 \notin \mathcal{L}_2$ because of $\text{Bad}_{\mathbf{P}}$ not occurring, since $R_5 \in \mathcal{L}_2$, and

$$R_4 = Y_1 \oplus R_5 \oplus Y_2 = R_1 \oplus \mathbf{F}_2(X) \oplus R_5 \oplus \mathbf{F}_2(X) \oplus R_2 = R_1 \oplus R_2 \oplus R_5.$$

Also, we have assumed that $\mathbf{F}_6(S_4) \oplus \bar{A} \notin \mathcal{L}_1$. But now, at some point, the chain going through X', Y_2, Z_1 , and \bar{A} has to be completed. However, this is not possible since $R_4 \notin \mathcal{L}_2$, and $\mathbf{F}_6(S_4) \oplus \bar{A} \notin \mathcal{L}_1$.

C A Stronger Attack

We subdivide the distinguisher execution into three phases: chain preparation, computation of chain values, and consistency check, and its description is best represented by means of the following tables: Note that if a value in the column *Queries to S* is named with the letter R (or X, Y, Z, A, S , respectively), it is issued to \mathbf{F}_1 (or $\mathbf{F}_2, \mathbf{F}_3, \mathbf{F}_4, \mathbf{F}_5, \mathbf{F}_6$, respectively).

Chain Preparation.

Step	D computes	Queries to S
1	$X := X_1 = X_2 = X_3 = X_4$ u.a.r.	
2	R_2, R_3 arbitrary s.t. $R_2 \neq R_3$	R_2, R_3
3	$S_2 T_2 := \mathbf{P}(X \oplus \mathbf{F}_1(R_2) R_2)$	S_2
4	$S_3 T_3 := \mathbf{P}(X \oplus \mathbf{F}_1(R_3) R_3)$	S_3
5	$A_2 := \mathbf{F}_6(S_2) \oplus T_2, A_3 := \mathbf{F}_6(S_3) \oplus T_3$	
6	$R_1 := R_2 \oplus A_2 \oplus A_3$	R_1
7	$S_1 T_1 := \mathbf{P}(X \oplus \mathbf{F}_1(R_1) R_1)$	S_1
8	$A_1 := \mathbf{F}_6(S_1) \oplus T_1$	
9	$A_5 := A_1 \oplus R_1 \oplus R_2$	
10	$R_4 := R_3 \oplus A_3 \oplus A_5$	R_4
11	$S_4 T_4 := \mathbf{P}(X \oplus \mathbf{F}_1(R_4) R_4)$	S_4
12	$A_4 := \mathbf{F}_6(S_4) \oplus T_4$	
13	$A_8 := A_4 \oplus R_4 \oplus R_3$	A_8

Computation of Chain Values.

Step	D computes	Queries to S
14		X
15		A_1, A_2, A_3, A_4
16	$Z_i := \mathbf{F}_5(A_i) \oplus S_i$ for $i = 1, 2, 3, 4$	Z_1, Z_2, Z_3, Z_4
17	$Y_i := \mathbf{F}_2(X) \oplus R_i$ for $i = 1, 2, 3, 4$	Y_1, Y_2, Y_3, Y_4
18	$Y_6 := Y_1, Y_5 := Y_2, Y_8 := Y_3, Y_7 := Y_4$	
19	$Z_5 := Z_1, Z_6 := Z_2, Z_7 := Z_3, Z_8 := Z_4$	
20	$A_6 := \mathbf{F}_4(Z_6) \oplus Y_6$	A_6
21	$X_5 := \mathbf{F}_3(Y_5) \oplus Z_5, X_6 := \mathbf{F}_3(Y_6) \oplus Z_6$	X_5, X_6
22	$R_5 := \mathbf{F}_2(X_5) \oplus Y_5, R_6 := \mathbf{F}_2(X_6) \oplus Y_6$	R_5, R_6
23	$S_5 T_5 := \mathbf{P}(X_5 \oplus \mathbf{F}_1(R_5) R_5)$	S_5
24	$S_6 T_6 := \mathbf{P}(X_6 \oplus \mathbf{F}_1(R_6) R_6)$	S_6
25		A_5
26	$X_7 := \mathbf{F}_3(Y_7) \oplus Z_7, X_8 := \mathbf{F}_3(Y_8) \oplus Z_8$	X_7, X_8
27	$R_7 := \mathbf{F}_2(X_7) \oplus Y_7, R_8 := \mathbf{F}_2(X_8) \oplus Y_8$	R_7, R_8
28	$S_7 T_7 := \mathbf{P}(X_7 \oplus \mathbf{F}_1(R_7) R_7)$	S_7
29	$S_8 T_8 := \mathbf{P}(X_8 \oplus \mathbf{F}_1(R_8) R_8)$	S_8
30	$A_7 := \mathbf{F}_4(Z_7) \oplus Y_7$	A_7

Consistency Check. Check if the following equations hold:

- (i) Chain Equalities: for $i = 1, 2, \dots, 8$ we have:
 $\mathbf{F}_1(R_i) = S_i \oplus X_i$, $\mathbf{F}_2(X_i) = R_i \oplus Y_i$, $\mathbf{F}_3(Y_i) = X_i \oplus Z_i$,
 $\mathbf{F}_4(Z_i) = Y_i \oplus A_i$, $\mathbf{F}_5(A_i) = Z_i \oplus S_i$, $\mathbf{F}_6(S_i) = A_i \oplus T_i$
- (ii) Equalities: $X_5 = X_6$, $X_7 = X_8$, $A_7 = A_5$, $A_6 = A_3$

If all the above equalities hold, output 1, else output 0.

Intuition behind the attack Figure 8 provides a picture of the dependencies between chains that have to be defined consistently by the simulator. The intuition behind this attack is as follows:

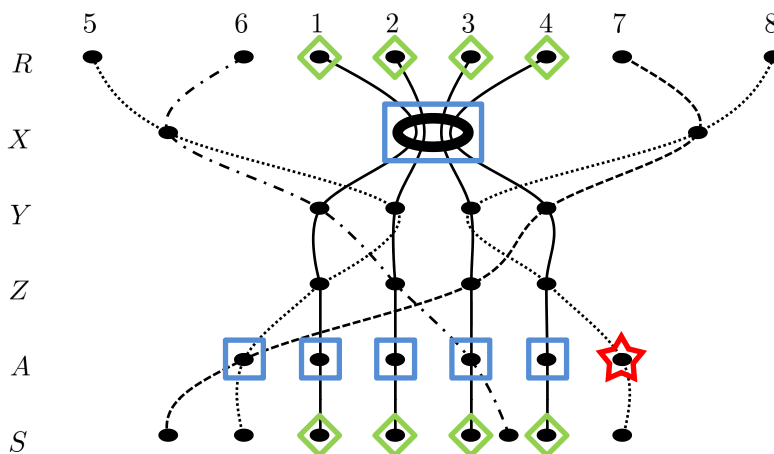

Figure 8: Illustration of the more general attack.

It seems that any simulator that completes chains one after another does not succeed: no matter in which order it completes the chains, it seems to always end up in a situation where some remaining chain cannot be completed consistently.