

The Impossibility of Non-Signaling Privacy Amplification

Esther Hänggi^a, Renato Renner^b, Stefan Wolf^a

^a *Computer Science Department, ETH Zurich, CH-8092 Zurich, Switzerland.
{esther.haengi, wolf}@inf.ethz.ch*

^b *Institute for Theoretical Physics, ETH Zurich, CH-8093 Zurich, Switzerland
renner@phys.ethz.ch*

Abstract

Barrett, Hardy, and Kent have shown in 2005 that protocols for quantum key agreement exist the security of which can be proven under the assumption that quantum *or* relativity theory is correct. More precisely, this is based on the non-local behavior of certain quantum systems, combined with the non-signaling postulate from relativity. An advantage is that the resulting security is independent of what (quantum) systems the legitimate parties' devices operate on: they do not have to be trusted. Unfortunately, the protocol proposed by Barrett *et al.* cannot tolerate any errors caused by noise in the quantum channel. Furthermore, even in the error-free case it is inefficient: its communication complexity is $\Theta(1/\varepsilon)$ when forcing the attacker's information below ε , even if only a single key bit is generated. Potentially, the problem can be solved by *privacy amplification* of relativistic — or non-signaling — secrecy. We show, however, that such privacy amplification is impossible with respect to the most important form of non-local behavior, and application of arbitrary hash functions.

Key words: Device-independent security, quantum key agreement, Bell inequalities, non-locality, cryptography

1. Introduction, Motivation, and Our Contribution

1.1. What is Relativistic Cryptography?

The security of *relativistic cryptography* can be proven under the sole assumption that the non-signaling postulate of relativity theory is correct. The latter states that information transmission faster than at the speed of light is impossible. The basic idea, as proposed by Barrett, Hardy, and Kent [4], is as follows: By communication over a quantum channel, two parties, Alice and Bob, generate some shared entangled quantum state. They then can carry out measurements and use an authentic classical channel to determine the resulting correlation of their respective data.

So far, this is entanglement-based quantum cryptography as proposed by Ekert [14]¹ some years after the first quantum key distribution protocol, proposed by Bennett and

¹Interestingly, the title of Ekert's celebrated article, "Quantum cryptography based on Bell's theorem," suits much more precisely — and might have anticipated in some way — the idea of relativistic cryptography based on non-local correlations: Here, the security proof is directly based on Bell's theorem, which is not the case for Ekert's protocol.

Brassard [7] that is not based on entanglement at all. Let us quickly follow Ekert's path: From the correlations, they conclude on error rates and adversarial information and generate a key, the security of which can be proven based on the assumption that quantum physics with all its Hilbert-space formalism is correct [21]. An additional assumption that usually has to be made is that the devices operate on specified quantum systems of given dimension (e.g., single polarized photons); the security is lost when the actual systems are different (e.g., pairs of photons). The question of device-independent security has been raised already in [1]. It was shown that under certain restrictions on the type of possible attacks, namely to so-called collective, i.e., *i.i.d.*, attacks, it can be achievable at the price of a lower key-generation rate.

Let us now turn back to *relativistic cryptography*: Here, Alice and Bob carry out measurements on their respective systems in a space-like separated fashion (to exclude signaling), and this will allow them to conclude privacy *directly* from the correlations of their resulting data. The proofs then hold for whatever quantum systems the devices operate on; no Hilbert space formalism is used, only classical information theory. Actually, the assumption is not even necessary that the possibilities of what an adversary can do is limited by quantum physics. Quantum physics guarantees the protocol to work, i.e., establishes the expected correlations, the occurrence of which can be verified, *but the security is completely independent of quantum physics*. An interesting consequence is that protocols can be given which are secure if *either* quantum physics *or* relativity (or both, of course) is correct.

How can it be possible to derive secrecy from correlations alone? In quantum physics, this effect is well-known: Quantum correlations, called *entanglement*, are monogamous to some extent [23]. If Alice and Bob are maximally entangled, then Eve must be out of the picture. But classically, we do not know such an effect: If Alice and Bob have highly correlated bits, Eve can nevertheless know them. The point is that we have to look at correlations of *systems*, i.e., bipartite input-output behaviors.

John Bell has proven in 1964 [5] that entangled quantum states can display *non-local correlations* under measurements. More precisely, the system consists of the choice of the particular measurement to be carried out — the inputs — and the corresponding outcomes — the outputs. Bell's work was a reply to Einstein, Podolsky, and Rosen's claim [13] that quantum physics was incomplete and should be augmented by classical variables determining the behavior of every system under any possible measurement. Bell proved that such a thing is impossible: these variables do not exist. This is what can be exploited cryptographically: If they do not exist, then no adversary can have known them before a measurement was carried out.

We explain this in more detail and start with a closer look at systems and correlations.

1.2. Systems, Correlations, and Non-Localities

In order to explain the essence of non-locality, we introduce the notion of *two-partite systems*, defined by their joint input-output behavior $P_{XY|UV}$ (see Figure 1). We classify systems by the correlation they introduce and by the resource required to explain the joint behavior of its parts.

Definition 1. A *system* is a bi- (or more-) partite conditional probability distribution $P_{XY|UV}$. A system $P_{XY|UV}$ is *independent* if $P_{XY|UV} = P_{X|U} \cdot P_{Y|V}$. It is *local* if

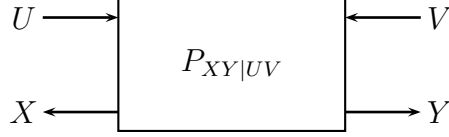

Figure 1: A two-partite system.

$P_{XY|UV} = \sum_{i=1}^n w_i P_{X|U}^i P_{Y|V}^i$ holds for some weights $w_i \geq 0$ and conditional distributions $P_{X|U}^i$ and $P_{Y|V}^i$, $i = 1, \dots, n$. A system is *signaling* if it allows for message transmission, i.e., there exist P_U and P_V such that $I(X; V|U) > 0$ or $I(Y; U|V) > 0$ ². We call a non-signaling system a *box*.

In terms of *classical* resources required to establish them, these categories correspond to no resources at all, shared information, and message transmission, respectively. Of interest for us will be systems that are *neither local nor signaling*, i.e., non-local boxes. Communication is required to explain their behavior classically, but for some of them, distributed *quantum* information is sufficient. Note that because they are non-signaling, this does not contradict relativity. We give an alternative characterization of locality.

Lemma 1. *For any system $P_{XY|UV}$, where \mathcal{U} and \mathcal{V} are the ranges of U and V , respectively, the following conditions are equivalent:*

1. $P_{XY|UV}$ is local,
2. there exist random variables X_u ($u \in \mathcal{U}$) and Y_v ($v \in \mathcal{V}$) with a joint distribution that is such that the marginals satisfy $P_{X_u Y_v} = P_{XY|U=u, V=v}$.

Proof. Assume first that $P_{XY|UV}$ is local, i.e., $P_{XY|UV} = \sum w_i P_{X|U}^i P_{Y|V}^i$. For $\mathcal{U} = \{u_1, u_2, \dots, u_m\}$ and $\mathcal{V} = \{v_1, v_2, \dots, v_n\}$, define

$$P_{X_{u_1} \dots X_{u_m} Y_{v_1} \dots Y_{v_n}}(x_1, \dots, x_m, y_1, \dots, y_n) := \sum w_i P_{X|U=u_1}^i(x_1) \cdots P_{X|U=u_m}^i(x_m) \cdot P_{Y|V=v_1}^i(y_1) \cdots P_{Y|V=v_n}^i(y_n).$$

This distribution has the desired property.

To see the reverse direction, let $X_{u_1} \cdots X_{u_m} Y_{v_1} \cdots Y_{v_n}$ be the shared randomness w . □

Intuitively speaking, we can simply forget about the inputs, and all the alternative outputs can be put under the roof of a single joint distribution (see Figure 2).

² Alternatively, signaling systems can be defined as systems which are *not* non-signaling; a *non-signaling* system being one for which

$$\begin{aligned} \sum_x P_{XY|UV}(x, y, u, v) &= \sum_x P_{XY|UV}(x, y, u', v) \text{ for all } y, v, u, u', \\ \sum_y P_{XY|UV}(x, y, u, v) &= \sum_y P_{XY|UV}(x, y, u, v') \text{ for all } x, u, v, v' \end{aligned}$$

holds. The two definitions are equivalent.

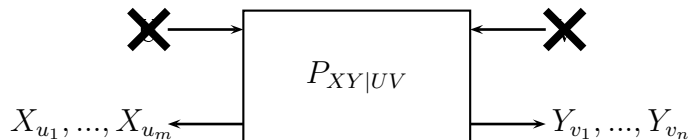

Figure 2: Locality is realism.

Lemma 1 connects *locality* with so-called *realism*: All the outputs to the alternative inputs “co-exist” — and can, hence, be pre-selected — in a consistent way. In other words, non-locality necessarily means that certain data do *not exist* before an input is provided on the respective side.

1.3. Non-Localities Implies Secrecy

In order to explain this more explicitly, let us consider a specific example of a system.

Definition 2. [20] A *Popescu-Rohrlich box* (or *PR box* for short) is the following two-partite system $P_{XY|UV}$: The random variable X is a random bit, given the pair (U, V) , and we have

$$\text{Prob} [X \oplus Y = U \cdot V] = 1 . \quad (1)$$

Bell’s theorem states that this system is indeed non-local. More precisely, any system that behaves like a PR box with probability superior to 75% is. Interestingly, the probabilities coming from measurements on bipartite entangled quantum states — considering the choice of a measurement as the input and the measurement result as the output — can achieve roughly 85%.

Theorem 2. (John Bell, 1964 [5].) *Any system that behaves like a PR box with probability > 75% for random inputs is non-local.*

Proof sketch. Lemma 1 states that a system is local only if the alternative outputs (i.e., outputs to alternative inputs) consistently co-exist. In the case of the PR box, this corresponds to a joint distribution of four bits $P_{X_0X_1Y_0Y_1}$ such that $\text{Prob} [X_0 = Y_0] = \text{Prob} [X_0 = Y_1] = \text{Prob} [X_1 = Y_0] = 1$ and $\text{Prob} [X_1 \neq Y_1] = 1$ hold. These conditions are contradictory: Only three out of the four can be satisfied at a time. \square

Note that although in terms of classical resources, the behavior of a PR box can be explained by message transmission only, the system is actually non-signaling: X and Y separately are perfectly random bits and independent of the input pair. On the other hand, a system $P_{XY|UV}$ (where all variables are bits) satisfying (1) is non-signaling *only* if the outputs are completely unbiased, given the input pair, i.e., $P_{X|U=u, V=v}(0) = P_{Y|U=u, V=v}(0) = 1/2$. In other words, the output bit cannot be pre-determined, not even slightly biased. The outputs are, hence, perfectly random and the randomness must have been generated *after* input reception. This is what we can make use of for key agreement: Assume that Alice and Bob share any kind of physical system, carry out space-like separated measurements (hereby excluding message transmission), and

measure data having the statistics of a PR box. (In order to test this, they exchange all the input bits and some randomly chosen outputs.) The resulting data are then perfectly secret bits, because even conditioned on an adversary’s complete information, the correlation between Alice and Bob must be non-signaling!

Unfortunately, however, perfect PR boxes do not exist in nature: Quantum physics is non-local, but not maximally³. Can we still obtain virtually secret bits from weaker, quantum-physically achievable, non-locality? Barrett, Hardy, and Kent [4] have shown that the answer is *yes*; but their protocol is inefficient: In order to reduce the probability that the adversary learns a generated bit shared by Alice and Bob below ε , they have to communicate $\Theta(1/\varepsilon)$ Qbits. Barrett *et al.*’s protocol and its analysis are based on a type of non-locality different from the one modeled by the PR box — the latter is typically referred to as CHSH [12] non-locality.

Masanes and Winter [19] proposed to use a number of 85%-approximations to the PR box (this is achievable with so-called *singlets*, i.e., maximally entangled Qbit pairs)⁴. Indeed, any, even weak, non-locality implies *some* secrecy, but no perfect secrecy in general. In order to illustrate this, consider a system approximating a PR box with probability $1 - \varepsilon$ for all inputs. More precisely, we have

$$\text{Prob } [X \oplus Y = U \cdot V | U = u, V = v] = 1 - \varepsilon \quad (2)$$

for all $(u, v) \in \{0, 1\}^2$. Then, what is the maximal possible bias

$$p := \text{Prob } [X = 0 | U = 0, V = 0]$$

such that the system is non-signaling?

u	$P_{X U=u, V=v}(0)$	$P_{Y U=u, V=v}(0)$	v
0	p	$p - \varepsilon$	0
0	p	$p - \varepsilon$	1
1	$p - 2\varepsilon$	$p - \varepsilon$	0
1	$p - 2\varepsilon$	$p - \varepsilon$	1

We explain the table: Because of (2), the bias of Y , given $U = V = 0$, must be at least $p - \varepsilon$. Because of non-signaling, X ’s bias must be p as well when $V = 1$, and so on. Finally, condition (2) for $U = V = 1$ implies $p - \varepsilon - (1 - (p - 2\varepsilon)) \leq \varepsilon$, hence, $p \leq 1/2 + 2\varepsilon$. For any $\varepsilon < 1/4$, this is a non-trivial bound. (This reflects the fact that $\varepsilon = 1/4$ is the “local limit,” as we have seen in the proof of Bell’s theorem.) If we apply this, conditioned on Eve’s knowledge, we obtain a lower bound on her uncertainty which is the better the stronger the non-locality is. (A special case is what we have seen above already: *maximal* CHSH non-locality leads to *perfect* secrecy.)

In this paper we consider privacy amplification applied to the outputs of non-local boxes. Privacy amplification is a concept well-known from classical [8], [15], [6] and

³It is a fundamental question, studied by many researchers, why this is the case. Is there a classical significance to the 85%-bound?

⁴The analysis of privacy amplification given in the original paper [19] led to a result which seems to be in contradiction to our claim that privacy amplification is impossible. In the mean-time it has been realized that the security definition used in [19] is incomplete and would only be sufficient if the adversary had to measure before the hash function becomes public (see [18] for a revised version).

quantum [16] cryptography, and means transforming a weakly secret string into a highly secret key by hashing. Because the security of privacy amplification ultimately depends on the abilities of an adversary, security in the context of an adversary governed by quantum mechanics [21] does not necessarily imply security in the context of an adversary only restricted by the non-signaling condition (modeled by the boxes introduced above). In this latter context, security is only known to hold under the additional assumption that the adversary can only attack each of the boxes separately [3], [22], [2]. In general, however, an adversary may of course attack all of them jointly (corresponding to a coherent attack⁵). Such a more general scenario has been considered by Masanes [17] (see also [18]), where the non-signaling postulate is imposed not only between the different parties, but also between subsystems held by one party. In this case, privacy amplification is indeed possible, but this solution requires n devices which are space-like separated and is therefore not practical. We consider the general situation where only a space-like separation between Alice and Bob is imposed and Eve can make arbitrary attacks.

1.4. Our Result: Amplification of Relativistic Privacy is Impossible

We state our main result informally. We look at the following scenario: in a first phase Alice and Bob have access to n realizations of a $(1 - \varepsilon)$ -approximation of a PR box. In a second phase, they can communicate over an authentic but public classical channel, and apply arbitrary one-bit-output functions to their data set. We then show that, for any such function, they can only reduce the information that a general non-signaling adversary can have about the bit, when compared to the raw bits output by the boxes, by at most a factor 4. In other words, privacy amplification by hashing is impossible in the relativistic-cryptography setting.

1.5. Outline

The rest of our paper is organized as follows. In Section 2, we describe the general set of possible strategies of a non-signaling adversary. In Section 3, we illustrate the power of a non-signaling adversary by showing that the XOR of n boxes' output bits is not more secure against a non-signaling attack than a single bit — quite the opposite, in fact. We also describe one concrete (good) adversarial strategy, which allows the adversary to obtain high information about the key bit. This is a special case of our general privacy-amplification no-go result stated in Section 4, which shows that privacy amplification by *any* hash function is impossible.

2. Preliminaries

2.1. Purification of Bipartite Non-Signaling Systems⁶

Assume Alice and Bob share a box. When we take the adversary into account, we get a three-partite scenario. The goal of this section is to reduce this tripartite scenario to

⁵In quantum mechanics, three types of attacks — individual, collective and coherent attacks — are generally considered [11], [10], [9]. In an individual attack, the eavesdropper attacks and measures each system identically and independently; in a collective attack the adversary still attacks each system identically and independently, but can make a joint measurement; finally the strongest attack is a coherent attack, where no restrictions apply.

⁶In quantum mechanics, the purification of a bipartite state is the extension of the state to a third party such that the overall state is pure.

a bipartite one: Given the box Alice and Bob share, what is the most general extension to a third party? This third party will take the role of the adversary.

According to the non-signaling assumption, even the three-partite scenario including the eavesdropper must not allow for signaling. For instance, we have⁷ $P(xy|uvw) = P(xy|uw)$ and $P(x|u) = P(x|uw)$, and so on.

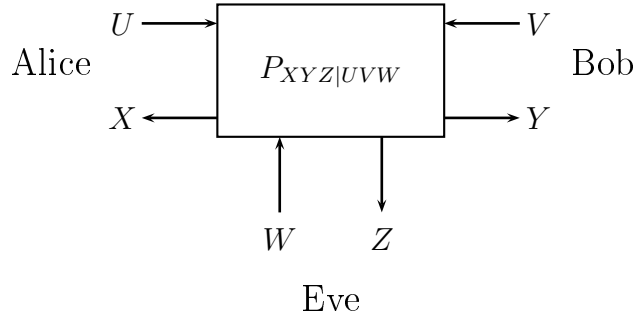

Figure 3: The three-partite scenario including the eavesdropper.

Note that because of the non-signaling property, the *marginal box* (in the very same sense as a marginal probability distribution) of Alice and Bob is well-defined: Their input-output statistics do not depend on what the adversary does, i.e., inputs.

The marginal system $P_{XY|UV}$ corresponds to a box. We will use the notation X (Y , U , V) for binary random variables, boldface letters \mathbf{X} for n -bit random variables and X_i for the i 'th random bit. The values that the random variable take will be denoted by lower-case letters. Note that considering only a single box includes the case where Alice and Bob share many boxes, because these can be seen as one box as long as Alice and Bob each give all their inputs simultaneously⁸. Eve can then attack all these boxes at once through a single input/output interface. This is analogous to an Eve being capable of doing collective attacks in quantum key distribution. Eve's random variables W and Z can have any range. Eve's input w corresponds to the choice of her strategy. In general, we must assume that Eve can delay her choice until all other parameters are known. In an informal way, we can write Eve's possibilities as

$$\begin{aligned}
 \boxed{A \ B} &= p(z_0|w) \cdot \boxed{A \ B}_{z_0} + p(z_1|w) \cdot \boxed{A \ B}_{z_1} + \dots \\
 &= p(z'_0|w') \cdot \boxed{A \ B}_{z'_0} + p(z'_1|w') \cdot \boxed{A \ B}_{z'_1} + \dots
 \end{aligned}$$

Eve's strategy w corresponds to a decomposition of Alice's and Bob's box. Her measurement result z tells her which part of the decomposition occurred.

⁷For the sake of simplicity, we drop indices that name the random variables when they are obvious.

⁸More precisely, Alice gives all her inputs at a given point in space-time and likewise for Bob

Definition 3. A *box partition*⁹ of a given box $P_{\mathbf{XY}|\mathbf{UV}}$ is a family of pairs $(p^z, P_{\mathbf{XY}|\mathbf{UV}}^z)$, where p^z is a weight and $P_{\mathbf{XY}|\mathbf{UV}}^z$ is a box, such that

$$P_{\mathbf{XY}|\mathbf{UV}} = \sum_z p^z \cdot P_{\mathbf{XY}|\mathbf{UV}}^z. \quad (3)$$

Because of the non-signaling condition, the marginal distribution of Alice and Bob must be the same, no matter Eve's strategy. The fact that any two parties cannot signal to the third party (for example, Alice and Eve together cannot signal to Bob) implies that every box defined by the behavior of the box shared by Alice and Bob conditioned on an outcome z , $P_{\mathbf{XY}|\mathbf{UV}, W=w, Z=z}$, must be non-signaling. This is, therefore, the most general way to describe a valid strategy of Eve as stated by the following lemmas.

Lemma 3. For any given tripartite box $P_{\mathbf{XYZ}|\mathbf{UV}W}$ any input w induces a box partition parametrized by z : $p^z := p(z|w)$, $P_{\mathbf{XY}|\mathbf{UV}}^z := P_{\mathbf{XY}|\mathbf{UV}, Z=z, W=w}$.

Lemma 4. Given a bipartite box $P_{\mathbf{XY}|\mathbf{UV}}$ let \mathcal{W} be a set of box partitions

$$w = \{(p^z, P_{\mathbf{XY}|\mathbf{UV}}^z)\}_z.$$

Then the tripartite box, where the input of the third part is $w \in \mathcal{W}$, defined by

$$P_{\mathbf{XYZ}|\mathbf{UV}, W=w}(z) := p^z \cdot P_{\mathbf{XY}|\mathbf{UV}}^z$$

is non-signaling and has marginal box $P_{\mathbf{XY}|\mathbf{UV}}$.

From now on, w will stand for a certain box partition, i.e., an adversarial strategy. We are interested in the question: Which type of box, given outcome z , can occur with what probability p^z ? Let us show that in order to answer this question, it is enough to look at the case where Eve only has *two* possible measurement outcomes z_0 and z_1 , as all other outcomes can be wrapped into a single one. The reason is that the space of non-signaling boxes is convex. We have

$$\boxed{A \quad B} = p^{z_0} \cdot \boxed{A \quad B}_{z_0} + \underbrace{p^{z'_1} \cdot \boxed{A \quad B}_{z'_1} + \dots + p^{z'_m} \cdot \boxed{A \quad B}_{z'_1}}_{p^{z_1} \cdot \boxed{A \quad B}_{z_1}}$$

where $p^{z_1} = p^{z'_1} + \dots + p^{z'_m}$.

Lemma 5. If $(p^{z_0}, P_{\mathbf{XY}|\mathbf{UV}}^{z_0})$ is an element of a box partition with m elements, then it is also an element of a box partition with only two elements.

⁹This is analogous to quantum mechanics, where bipartite states are described by density operators ρ_{AB} and where any measurement on a purifying system corresponds to a partition of the form $\rho_{AB} = \sum_z p^z \rho_{AB}^z$, where ρ_{AB}^z is the state conditioned on the measurement outcome z .

Proof. We define the probability of outcome z_1 as $p^{z_1} = p^{z'_1} + \dots + p^{z'_m}$ and the box given outcome z_1 as

$$P_{\mathbf{XY}|\mathbf{UV}}^{z_1} := \frac{1}{p^{z_1}} \sum_{i=1}^m p^{z'_i} P_{\mathbf{XY}|\mathbf{UV}}^{z'_i} .$$

The marginal distribution defined in this way is the one expected by Alice and Bob because of

$$p^{z_0} P_{\mathbf{XY}|\mathbf{UV}}^{z_0} + p^{z_1} P_{\mathbf{XY}|\mathbf{UV}}^{z_1} = p^{z_0} P_{\mathbf{XY}|\mathbf{UV}}^{z_0} + \sum_{i=1}^m p^{z'_i} P_{\mathbf{XY}|\mathbf{UV}}^{z'_i} = P_{\mathbf{XY}|\mathbf{UV}} .$$

It remains to show that $P_{\mathbf{XY}|\mathbf{UV}}^{z_1}$ is a valid non-signaling probability distribution. The convex combination of several probabilities is again a probability between 0 and 1 and the normalization remains because every part is normalized separately. The distribution is non-signaling because every single part is (the non-signaling property is linear). Therefore, $P_{\mathbf{XY}|\mathbf{UV}}^{z_1}$ is a valid non-signaling probability distribution, and the two outcomes z_0 and z_1 define a box partition. \square

Lemma 5 implies that for showing an impossibility result, we can assume Eve's information (the random variable Z) to be binary. Moreover, we will now show that it is not necessary to determine both parts of the box partition explicitly, but we can find a condition on the box given outcome $z = 0$, which will make sure that there exists a second part, complementing it to a box partition.

Lemma 6. *Given a non-signaling distribution $P_{\mathbf{XY}|\mathbf{UV}}$, there exists a box partition with element $(p, P_{\mathbf{XY}|\mathbf{UV}}^{Z=0})$ if and only if for all inputs and outputs $\mathbf{x}, \mathbf{y}, \mathbf{u}, \mathbf{v}$,*

$$p \cdot P^{Z=0}(\mathbf{xy}|\mathbf{uv}) \leq P(\mathbf{xy}|\mathbf{uv}) . \quad (4)$$

Proof. The convex combination of boxes $P_{\mathbf{XY}|\mathbf{UV}}^{Z=z}$ is again a box. To prove that the outcome $z = 0$ can occur with probability p it is, therefore, needed to show that there exists another valid outcome $z = 1$ which can occur with probability $1 - p$, and that the weighted sum of the two is $P_{\mathbf{XY}|\mathbf{UV}}$. If $P_{\mathbf{XY}|\mathbf{UV}}^{Z=0}$ is a normalized and non-signaling probability distribution, then so is $P_{\mathbf{XY}|\mathbf{UV}}^{Z=1}$, because the sum of the two $P_{\mathbf{XY}|\mathbf{UV}}$ is also non-signaling and normalized. Therefore, we only need to verify that all entries of the complementary box $P_{\mathbf{XY}|\mathbf{UV}}^{Z=1}$ are between 0 and 1. However, this box is the difference

$$P_{\mathbf{XY}|\mathbf{UV}}^{Z=1} = \frac{1}{1-p} (P_{\mathbf{XY}|\mathbf{UV}} - p \cdot P_{\mathbf{XY}|\mathbf{UV}}^{Z=0}) .$$

Requesting this to be greater or equal to 0 is equivalent to (4). We observe that all entries of $P_{\mathbf{XY}|\mathbf{UV}}^{Z=1}$ are now trivially smaller than or equal to 1 because of the normalization: if the sum of positive summands is 1, each of them can be at most 1. \square

2.2. Description of the Scenario and Security Criteria

We study the scenario where Alice and Bob share several approximations of PR boxes. Alice and Bob can test the behavior of the boxes, but we assume that this has

already been done, and that the boxes behave exactly as expected by Alice and Bob; more precisely, we assume that Alice and Bob share n independent and unbiased PR boxes with error ε , defined below.

Definition 4. An *unbiased PR box with error ε* is a system $P_{XY|UV}$, where X, Y, U, V are bits, and for every pair (U, V) X and Y are random bits, and

$$\text{Prob } [X \oplus Y = U \cdot V] = 1 - \varepsilon$$

(see also (6)).

The marginal box as seen by Alice and Bob can, therefore, be expressed as

$$P_{\mathbf{X}\mathbf{Y}|\mathbf{U}\mathbf{V}} := \prod_{i=1}^n P_{X_i Y_i | U_i V_i} ,$$

where $P_{X_i Y_i | U_i V_i}$ is a single unbiased PR box with error ε . This assumption only restricts Eve's possibilities as compared to the case when the marginal is not fixed. To create a key, Alice and Bob take a public input and a public hash function f and apply f to the outcomes of the boxes. The quality of the resulting key can be measured by the distance from the uniform distribution given the adversary's knowledge. In general, the goal of privacy amplification is to create a highly secure bit-string. However, the non-uniformity of the key is lower-bounded by the non-uniformity of a single bit; for showing the impossibility of privacy amplification, it is, therefore, enough to show that the non-uniformity of a single bit is always high. (Indeed, if Alice and Bob cannot even create a single secure bit, they can surely not create several secure bits.)

Since in the protocol, Bob adjusts his output bit to Alice's after the exchange of their inputs, it is enough for Eve to know the output of Alice's hashing, $f(\mathbf{x})$. For taking into account the most general non-signaling attack, we must assume that Eve can adapt her strategy to the choice of f and the inputs. In our case, it will in fact be sufficient for Eve to choose a strategy with only two outputs, $z = 0$ and $z = 1$, each occurring with probability $1/2$, such that given $z = 0$, $f(\mathbf{X})$ is maximally biased towards 0. The knowledge Eve has about the key bit $f(\mathbf{X})$ can be seen as the non-uniformity of this bit, given her outcome z . Obviously, this quantity depends on Eve's strategy (the box partition she uses), Alice's and Bob's inputs and the hash function that is applied to the output bits.

Definition 5. The *non-uniformity* of the bit $f(\mathbf{X})$ given a box partition w and input \mathbf{u}, \mathbf{v} is

$$\delta_w^f(\mathbf{u}, \mathbf{v}) = \frac{1}{2} \sum_z p^z \cdot \left| P_{\mathbf{X}\mathbf{Y}|\mathbf{U}\mathbf{V}}^z(f(\mathbf{x}) = 0|\mathbf{u}\mathbf{v}) - P_{\mathbf{X}\mathbf{Y}|\mathbf{U}\mathbf{V}}^z(f(\mathbf{x}) = 1|\mathbf{u}\mathbf{v}) \right| .$$

Here $\delta_w^f(\mathbf{u}, \mathbf{v}) = 0$ means that the eavesdropper has no knowledge about the bit $f(\mathbf{X})$; on the other hand, $\delta_w^f(\mathbf{u}, \mathbf{v}) = 1/2$ corresponds to complete knowledge. Our goal will be to show that the non-uniformity remains high, no matter what function Alice (and Bob) apply to their output bits and how many boxes they share.

2.3. The Case of a Single Box

In this section, we will show that the knowledge of a non-signaling adversary about the outcome of a box which is non-local is limited, i.e., we consider the case where $P_{XY|UV}$ corresponds to a single unbiased PR box with error ε , and the function that is applied is the identity $f = id$. This is a more detailed justification for the claim already made in Section 1.3, which also shows that the bound given there is tight. The marginal probability distribution as seen by Alice and Bob is given by

		U					
		0		1			
V	X	0		1			
	Y	0	1	0	1		
0	0	$\frac{1}{2} - \frac{\varepsilon}{2}$	$\frac{\varepsilon}{2}$	$\frac{1}{2} - \frac{\varepsilon}{2}$	$\frac{\varepsilon}{2}$		
0	1	$\frac{\varepsilon}{2}$	$\frac{1}{2} - \frac{\varepsilon}{2}$	$\frac{\varepsilon}{2}$	$\frac{1}{2} - \frac{\varepsilon}{2}$		
1	0	$\frac{1}{2} - \frac{\varepsilon}{2}$	$\frac{\varepsilon}{2}$	$\frac{1}{2} - \frac{\varepsilon}{2}$	$\frac{\varepsilon}{2}$		
1	1	$\frac{\varepsilon}{2}$	$\frac{1}{2} - \frac{\varepsilon}{2}$	$\frac{1}{2} - \frac{\varepsilon}{2}$	$\frac{\varepsilon}{2}$		

(5)

The criteria that Alice cannot signal to Bob translates in this notation to the requirement that the probabilities in the light gray and dark gray areas are equal (and similarly for the other rows); that Bob cannot signal to Alice is expressed as the same kind of condition on the columns. The normalization criteria is that the probabilities within a double line must sum up to one.

As an example, we assume that the input bits of Alice and Bob were $(u, v) = (0, 0)$; for symmetry reasons it is clear that Eve has an equivalent strategy also for all other inputs. As shown in [24], the strategy giving maximal information about a bit to Eve is to choose a box partition with three outputs $z = \{0, 1, \delta\}$ such that if she obtains $z = 0$ she knows with certainty that Alice's bit x is 0 and if she obtains δ Alice's bit is a random bit.

$$P_{XY|UV} = p^{Z=0} P_{XY|UV}^{Z=0} + p^{Z=\delta} P_{XY|UV}^{Z=\delta} + p^{Z=1} P_{XY|UV}^{Z=1},$$

where $P^{Z=0}(x = 0|u = 0, v = 0) = 1$ and $P^{Z=1}(x = 1|u = 0, v = 0) = 1$. From the fact that the marginal box of Alice and Bob is unbiased, we can conclude $p^{Z=0} = p^{Z=1}$.

Using this box partition, the non-uniformity of the bit X is given by $\delta_w^{id}(0, 0) = 1/2(p^{Z=0} + p^{Z=1}) = p^{Z=0}$. However, because of the convexity of the theory, we can easily define another box partition w' with only two outcomes, $z' = 0$ and $z' = 1$, which also reaches this maximal non-uniformity by equally distributing the second (δ) outcome into the two others:

$$P_{XY|UV} = p^{Z'=0} P_{XY|UV}^{Z'=0} + p^{Z'=1} P_{XY|UV}^{Z'=1},$$

where $p^{Z'=0} = p^{Z'=1} = 1/2$ and

$$P_{XY|UV}^{Z'=0} = 2p^{Z=0} P_{XY|UV}^{Z=0} + (1 - 2p^{Z=0}) P_{XY|UV}^{Z=\delta}.$$

We, therefore, only have to find the box that is maximally biased towards 0 and which can occur with probability $1/2$. According to (4), this turns into a simple maximization

problem under linear constraints. The result can be written as follows (where the different entries of the table are $P_{XY|UV}^{Z=0}$):

		U		0		1	
		X	0	1	0	1	
V	Y		0	1	0	1	
	0	0	$\frac{1}{2} + \varepsilon$	0	$\frac{1}{2}$	ε	
1		ε	$\frac{1}{2} - 2\varepsilon$	0	$\frac{1}{2} - \varepsilon$		
1	0	$\frac{1}{2} + \varepsilon$	0	ε	$\frac{1}{2}$		
	1	ε	$\frac{1}{2} - 2\varepsilon$	$\frac{1}{2} - \varepsilon$	0		

(6)

This box has a bias of 2ε towards 0: We have $P^{Z'=0}(X=0) = 1/2 + 2\varepsilon$, which means that the non-uniformity of Alice's output bit given box partition w' is bounded by $\delta_w^{id}(0,0) = P^{Z'=0}(X=0) - 1/2 = 2\varepsilon$. This implies that in the case $\varepsilon = 0.25$, Eve can perfectly know Alice's output bit — which corresponds to our expectation since $\varepsilon = 0.25$ -boxes can be simulated with a local hidden-variable theory, and Eve could know the hidden variable. Additionally, for any non-local theory (i.e., $\varepsilon < 0.25$), the non-signaling condition bounds the knowledge of a potential adversary; with *perfect* PR boxes, one perfectly secret bit per use is created, the confidentiality of which relies only on the non-signaling condition, as we have explained in Section 1.3.

3. Impossibility of Privacy Amplification by Linear Hashing

In this section, we show that privacy amplification by applying a linear function — taking the XOR of some subset of the output bits — is impossible. Moreover, we will show that the more bits we take the XOR of, the more Eve can know. At the same time we try to give a more intuitive explanation of the possibilities Eve has, and explain why the strategy we give is actually a good strategy for Eve. The specific box partition we define here will also be used later in the case of general hash functions.

3.1. Intuitive Presentation of the Argument

Let us take as an example the case where Alice and Bob share only two boxes. Then we can define a table with input-output probabilities similar to (5) for the two boxes $P_{X_1 X_2 Y_1 Y_2 | U_1 U_2 V_1 V_2}$. Alice and Bob now have two bits of input and output. As the two boxes as seen by Alice and Bob are independent, the probabilities are simply the product of the input-output probabilities of each box. We give a part of this table — the part for the input $(u_1, u_2, v_1, v_2) = (0, 0, 0, 0)$:

		U_1U_2		00				
				X_1X_2	00	01	10	
00	Y_1Y_2	00	$\left(\frac{1}{2} - \frac{1}{2}\right) \cdot \left(\frac{1}{2} - \frac{1}{2}\right)$	$\left(\frac{1}{2} - \frac{1}{2}\right) \cdot \frac{1}{2}$	$\frac{1}{2} \cdot \left(\frac{1}{2} - \frac{1}{2}\right)$	$\frac{1}{2} \cdot \frac{1}{2}$	← row 1	
	01	$\left(\frac{1}{2} - \frac{1}{2}\right) \cdot \frac{1}{2}$	$\left(\frac{1}{2} - \frac{1}{2}\right) \cdot \left(\frac{1}{2} - \frac{1}{2}\right)$	$\frac{1}{2} \cdot \frac{1}{2}$	$\frac{1}{2} \cdot \left(\frac{1}{2} - \frac{1}{2}\right)$			
	10	$\frac{1}{2} \cdot \left(\frac{1}{2} - \frac{1}{2}\right)$	$\frac{1}{2} \cdot \frac{1}{2}$	$\left(\frac{1}{2} - \frac{1}{2}\right) \cdot \left(\frac{1}{2} - \frac{1}{2}\right)$	$\left(\frac{1}{2} - \frac{1}{2}\right) \cdot \frac{1}{2}$...		
	11	$\frac{1}{2} \cdot \frac{1}{2}$	$\left(\frac{1}{2} - \frac{1}{2}\right) \cdot \frac{1}{2}$	$\frac{1}{2} \cdot \left(\frac{1}{2} - \frac{1}{2}\right)$	$\frac{1}{2} \cdot \frac{1}{2}$			
			⋮					

Now, imagine further that Eve learns the input (later, we will see that this is, in fact, not necessary for her strategy to work), and that the function Alice applies is the XOR (which is the only non-trivial linear function). In the table we mark gray all outcomes for which Alice's final bit is 0 and as white the ones where she will get 1. What is Eve's strategy which gives her as much information as possible about Alice's final bit? Defining a strategy means constructing a decomposition of the double box into two parts corresponding to her two (equally likely) outputs:

$$\boxed{A \ B} = \frac{1}{2} \cdot \boxed{A \ B}_{z=0} + \frac{1}{2} \cdot \boxed{A \ B}_{z=1}$$

In fact, as we have seen before, we only need to construct one part $P_{XY|UV}^{Z=0}$ such that $z = 0$ can occur with probability $1/2$ according to (4); the second part is then automatically defined. As Eve has learned the input 0000 and knows that the function Alice applies is the XOR, we try to make the box given measurement outcome $z = 0$ maximally biased towards 0, that is, Alice's output bits should be likely to be either 00 or 11. In order to construct the conditional box, given measurement outcome $z = 0$, we start from the unbiased box as seen by Alice and Bob (given above) and shift around probabilities. More precisely, we try to take as much probability as possible out of the white area and put it into the gray area, therefore, biasing the XOR towards 0. However, we have to respect a few rules.

1. All entries must remain **probabilities** between 0 and 1.
2. The **normalization** of the probability distribution must remain — this will not be a problem as we only move around probability weights within the same input, taking them out of one cell and putting them into another.
3. The **non-signaling** condition must be satisfied — this implies that even the input is known, we must be able to define the conditional box, given output $z = 0$, for all inputs, and it must be possible to do this in a non-signaling way. We will not worry about this condition too much for the moment, as we will be able to show later that if we proceed as below for all inputs, the box obtained is in fact non-signaling.

4. There **must exist a second measurement outcome** $z = 1$ occurring with probability $1/2$, and such that the conditional box, given outcome $z = 1$, is also a valid probability distribution. This box, given outcome $z = 1$, must be able to compensate for the shifts in probabilities. According to (4), this means that the entry in every cell must be smaller or equal twice the original entry.

Rules 1 and 4 together state that every new entry must be between 0 and twice the original entry.

Now, we can proceed row-wise in the picture (a row corresponds to one specific output on Bob's side) and look at the probabilities in the gray and white areas — i.e., the probability for Alice's final bit to be 0 or 1 respectively. In case of the first row (corresponding to Bob's output $\mathbf{y} = y_1 y_2 = 00$), we see that the probability for Alice to obtain 00 or 11 is $(1/2 - \varepsilon/2)^2$ and $(\varepsilon/2)^2$, respectively, and to obtain 01 or 10 is $(1/2 - \varepsilon/2)(\varepsilon/2)$ each. We try to take as much probability as possible out of the white area and put it into the gray area. If the sum of probabilities in the white area is smaller than the one in the gray area, we can take *all* probability weight out of the white cells and distribute it in the gray cells proportionally to the original entry. As the white area is smaller than the gray, this will at most double the gray entries, and all entries will be within the range allowed by (4). This is the case here: $(1/2 - \varepsilon/2)^2 + (\varepsilon/2)^2 > 2(1/2 - \varepsilon/2)(\varepsilon/2)$, hence, the new entries in the white cells will be 0, and the new entries in the gray cells will be less than twice the amount that was there before. We will call rows of this type $\mathbf{y}_>$ (8), and a generalization of this argument will lead to (13), (14).

The second row is different: The probabilities in the gray area are lower than the ones in the white area $2(1/2 - \varepsilon/2)(\varepsilon/2) < (1/2 - \varepsilon/2)^2 + (\varepsilon/2)^2$, so we cannot shift the entire probability into the gray cells, because this would more than double the entries. The best we can do is to exactly double the entries in the gray region, and take exactly this probability (proportionally) out of the white cells, which means the amount of probability that is shifted is $2(1/2 - \varepsilon/2)(\varepsilon/2)$. This type of row will be called $\mathbf{y}_<$ (7), and the (generalized) expression of the new entries is given in (11), (12).

So, whether we look at a row of type $\mathbf{y}_<$ or $\mathbf{y}_>$, the amount of probability that is shifted is exactly the probability contained in the area with lower total probability (gray or white). The shifted probability will correspond exactly to the bias the box given outcome $z = 0$ has, so we just have to count the lower of the two areas on every row. This is what is said in (18). And this bias is exactly the non-uniformity of the key bit given box partition \bar{w} . In our example of two boxes and the XOR, the probability shift (area with the lower probability) happens to be $2(1/2 - \varepsilon/2)(\varepsilon/2)$ for every row, and there are four rows, therefore, $\delta_{example}^{XOR}(00, 00) = 4 \cdot 2(1/2 - \varepsilon/2)(\varepsilon/2) = 2\varepsilon - 2\varepsilon^2$. Finally, note that if we shift probabilities in this way for all inputs, the resulting box is in fact non-signaling. The fact that Alice cannot signal to Bob is satisfied because we do not shift probabilities between rows. Bob cannot signal to Alice because for every row, the same row (meaning: with the same sequence of probabilities) appears again for another input of Bob (maybe just in a different position) and the same shifts, therefore, occur for all inputs of Bob.

3.2. A Concrete (Good) Adversarial Strategy

Now we will define formally the box partition we described informally in the previous section. We describe a box partition \bar{w} which contains an element $(1/2, P_{\mathbf{XY}|\mathbf{UV}}^{Z=0})$, and which gives a high non-uniformity of the key bit $f(\mathbf{X})$. Our description will be rather general, such that this box partition can also be used when the function f is not the XOR. The probabilities $P^{Z=0}(\mathbf{x}, \mathbf{y}, \mathbf{u}, \mathbf{v})$ are defined in four cases according to \mathbf{x} , \mathbf{y} and the properties of the box $P_{\mathbf{XY}|\mathbf{UV}}$ (in terms of the intuitive explanation above: whether we are in a white or gray cell, whether there is more probability in the white or the gray area and according to the original entry in that cell). For simplicity, let us use the following notation:

$$\mathbf{y}_< := \left\{ \mathbf{y} \mid \sum_{\mathbf{x}|f(\mathbf{x})=0} P(\mathbf{xy}|\mathbf{uv}) < \sum_{\mathbf{x}|f(\mathbf{x})=1} P(\mathbf{xy}|\mathbf{uv}) \right\}, \quad (7)$$

$$\mathbf{y}_> := \left\{ \mathbf{y} \mid \sum_{\mathbf{x}|f(\mathbf{x})=0} P(\mathbf{xy}|\mathbf{uv}) > \sum_{\mathbf{x}|f(\mathbf{x})=1} P(\mathbf{xy}|\mathbf{uv}) \right\}, \quad (8)$$

$$\mathbf{x}_0 := \{ \mathbf{x} | f(\mathbf{x}) = 0 \}, \quad (9)$$

$$\mathbf{x}_1 := \{ \mathbf{x} | f(\mathbf{x}) = 1 \}. \quad (10)$$

Then $P^{Z=0}(\mathbf{xy}|\mathbf{uv})$ is defined as follows:

For all $\mathbf{x} \in \mathbf{x}_0, \mathbf{y} \in \mathbf{y}_<$:

$$P^{Z=0}(\mathbf{xy}|\mathbf{uv}) := 2 \cdot P(\mathbf{xy}|\mathbf{uv}). \quad (11)$$

For all $\mathbf{x} \in \mathbf{x}_1, \mathbf{y} \in \mathbf{y}_<$:

$$P^{Z=0}(\mathbf{xy}|\mathbf{uv}) := \frac{\sum_{\mathbf{x}|f(\mathbf{x})=1} P(\mathbf{xy}|\mathbf{uv}) - \sum_{\mathbf{x}|f(\mathbf{x})=0} P(\mathbf{xy}|\mathbf{uv})}{\sum_{\mathbf{x}|f(\mathbf{x})=1} P(\mathbf{xy}|\mathbf{uv})} \cdot P(\mathbf{xy}|\mathbf{uv}). \quad (12)$$

For all $\mathbf{x} \in \mathbf{x}_0, \mathbf{y} \in \mathbf{y}_>$:

$$P^{Z=0}(\mathbf{xy}|\mathbf{uv}) := \frac{\sum_{\mathbf{x}|f(\mathbf{x})=1} P(\mathbf{xy}|\mathbf{uv}) + \sum_{\mathbf{x}|f(\mathbf{x})=0} P(\mathbf{xy}|\mathbf{uv})}{\sum_{\mathbf{x}|f(\mathbf{x})=0} P(\mathbf{xy}|\mathbf{uv})} \cdot P(\mathbf{xy}|\mathbf{uv}). \quad (13)$$

For all $\mathbf{x} \in \mathbf{x}_1, \mathbf{y} \in \mathbf{y}_>$:

$$P^{Z=0}(\mathbf{xy}|\mathbf{uv}) := 0. \quad (14)$$

Lemma 7. *There exists a box partition with an element $(p^{Z=0} = 1/2, P^{Z=0}(\mathbf{xy}|\mathbf{uv}))$.*

Proof.

Alice cannot signal to Bob:

For all \mathbf{u}, \mathbf{v} and $\mathbf{y} \in \mathbf{y}_<$:

$$\begin{aligned}
\sum_{\mathbf{x}} P^{Z=0}(\mathbf{xy}|\mathbf{uv}) &= \sum_{\mathbf{x}|f(\mathbf{x})=0} 2 \cdot P(\mathbf{xy}|\mathbf{uv}) + \\
&\sum_{\mathbf{x}|f(\mathbf{x})=1} \frac{\sum_{\mathbf{x}'|f(\mathbf{x}')=1} P(\mathbf{xy}|\mathbf{uv}) - \sum_{\mathbf{x}'|f(\mathbf{x}')=0} P(\mathbf{xy}|\mathbf{uv})}{\sum_{\mathbf{x}'|f(\mathbf{x}')=1} P(\mathbf{xy}|\mathbf{uv})} \cdot P(\mathbf{xy}|\mathbf{uv}) \\
&= 2 \sum_{\mathbf{x}|f(\mathbf{x})=0} P(\mathbf{xy}|\mathbf{uv}) + \sum_{\mathbf{x}|f(\mathbf{x})=1} P(\mathbf{xy}|\mathbf{uv}) - \sum_{\mathbf{x}|f(\mathbf{x})=0} P(\mathbf{xy}|\mathbf{uv}) \\
&= \sum_{\mathbf{x}} P(\mathbf{xy}|\mathbf{uv}) = \frac{1}{2^n}.
\end{aligned} \tag{15}$$

For all \mathbf{u}, \mathbf{v} and $\mathbf{y} \in \mathbf{y}_>$:

$$\begin{aligned}
\sum_{\mathbf{x}} P^{Z=0}(\mathbf{xy}|\mathbf{uv}) &= \sum_{\mathbf{x}|f(\mathbf{x})=1} 0 \\
&+ \sum_{\mathbf{x}|f(\mathbf{x})=0} \frac{\sum_{\mathbf{x}'|f(\mathbf{x}')=1} P(\mathbf{xy}|\mathbf{uv}) + \sum_{\mathbf{x}'|f(\mathbf{x}')=0} P(\mathbf{xy}|\mathbf{uv})}{\sum_{\mathbf{x}'|f(\mathbf{x}')=0} P(\mathbf{xy}|\mathbf{uv})} \cdot P(\mathbf{xy}|\mathbf{uv}) \\
&= \sum_{\mathbf{x}|f(\mathbf{x})=1} P(\mathbf{xy}|\mathbf{uv}) + \sum_{\mathbf{x}|f(\mathbf{x})=0} P(\mathbf{xy}|\mathbf{uv}) = \frac{1}{2^n}.
\end{aligned} \tag{16}$$

Bob cannot signal to Alice: For this, we need the fact that

$$P(\mathbf{xy}|\mathbf{uv}') = P(\mathbf{xy}'|\mathbf{uv}),$$

where the i 'th bit of \mathbf{y}' is defined as $y'_i := y_i \oplus u_i \cdot (v'_i - v_i)$ and, therefore, we have for all $\mathbf{x}, \mathbf{u}, \mathbf{v}$:

$$\sum_{\mathbf{y}} P^{Z=0}(\mathbf{xy}|\mathbf{uv}') = \sum_{\mathbf{y}'} P^{Z=0}(\mathbf{xy}'|\mathbf{uv}) = \sum_{\mathbf{y}} P^{Z=0}(\mathbf{xy}|\mathbf{uv}). \tag{17}$$

Normalization: This follows directly from (15), (16):

$$\sum_{\mathbf{x}, \mathbf{y}} P^{Z=0}(\mathbf{xy}|\mathbf{uv}) = \sum_{\mathbf{y}} \left(\sum_{\mathbf{x}} P^{Z=0}(\mathbf{xy}|\mathbf{uv}) \right) = \sum_{\mathbf{y}} \frac{1}{2^n} = 1.$$

$p^{Z=0} = 1/2$: For the case $p = 1/2$ (4) translates to $P^{Z=0}(\mathbf{xy}|\mathbf{uv}) \leq 2 \cdot P(\mathbf{xy}|\mathbf{uv})$, which is satisfied due to the definition of $P^{Z=0}(\mathbf{xy}|\mathbf{uv})$. \square

We can define a complementary box $P^{Z=1}(\mathbf{xy}|\mathbf{uv}) = 2 \cdot P(\mathbf{xy}|\mathbf{uv}) - P^{Z=0}(\mathbf{xy}|\mathbf{uv})$, to give a box partition

$$P_{\mathbf{XY}|\mathbf{UV}} = \frac{1}{2} P^{Z=0}(\mathbf{xy}|\mathbf{uv}) + \frac{1}{2} P^{Z=1}(\mathbf{xy}|\mathbf{uv}).$$

The bias of the bit $f(\mathbf{X})$ for the box $P_{\mathbf{XY}|U\mathbf{V}}^{Z=0}$ and, therefore, also $\delta_{\bar{w}}^f(\mathbf{u}, \mathbf{v})$ is given by

$$\delta_{\bar{w}}^f(\mathbf{u}, \mathbf{v}) = \sum_{\mathbf{y}} \min \left\{ \sum_{\mathbf{x}|f(\mathbf{x})=0} P(\mathbf{xy}|\mathbf{uv}), \sum_{\mathbf{x}|f(\mathbf{x})=1} P(\mathbf{xy}|\mathbf{uv}) \right\}, \quad (18)$$

3.3. The Impossibility Result

We will now show that Alice cannot use any linear function — XOR of some of her output bits — to do privacy amplification. There always exists a box partition (namely \bar{w}) such that the non-uniformity of the key bit given \bar{w} is bigger than ε , the error of the box: $\delta_{\bar{w}}^f(\mathbf{u}, \mathbf{v}) \geq \varepsilon$. Furthermore, taking the XOR of many output bits is actually counter-productive, as the non-uniformity of the key bit grows in the number of bits the XOR is taken of, and in the limit of large n , Eve can even have close-to-perfect knowledge about Alice's final bit.

Lemma 8. *For all linear hash functions $f : \{0, 1\}^n \rightarrow \{0, 1\}$, the non-uniformity of the bit $f(\mathbf{X})$ given box partition \bar{w} is larger than ε : $\delta_{\bar{w}}^f(\mathbf{u}, \mathbf{v}) \geq \varepsilon$.*

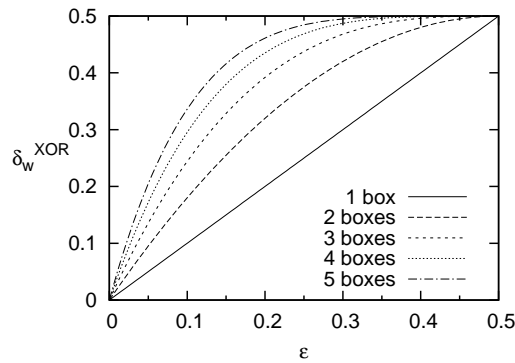

Figure 4: The lower bound on the non-uniformity of the final bit (XOR of all outputs) as given by (19) as function of number of boxes and error. Note that the non-trivial region of ε is below 0.25.

Proof. If the function f is the XOR, we can explicitly determine the non-uniformity of the bit $f(\mathbf{X})$ given the box partition \bar{w} . In fact, we have either

$$\begin{aligned} \sum_{\mathbf{x}|\oplus_i x_i=0} P(\mathbf{xy}|\mathbf{uv}) &= \binom{n}{n} \left(\frac{1-\varepsilon}{2}\right)^n + \binom{n}{n-2} \left(\frac{1-\varepsilon}{2}\right)^{n-2} \left(\frac{\varepsilon}{2}\right)^2 \\ &\quad + \binom{n}{n-4} \left(\frac{1-\varepsilon}{2}\right)^{n-4} \left(\frac{\varepsilon}{2}\right)^4 + \dots \\ \sum_{\mathbf{x}|\oplus_i x_i=1} P(\mathbf{xy}|\mathbf{uv}) &= \binom{n}{n-1} \left(\frac{1-\varepsilon}{2}\right)^{n-1} \left(\frac{\varepsilon}{2}\right)^1 \\ &\quad + \binom{n}{n-3} \left(\frac{1-\varepsilon}{2}\right)^{n-3} \left(\frac{\varepsilon}{2}\right)^3 + \dots \end{aligned}$$

or *vice versa*. Therefore,

$$\begin{aligned}
\delta_{\bar{w}}^{XOR}(\mathbf{u}, \mathbf{v}) &= \sum_y \min \left\{ \binom{n}{n} \left(\frac{1}{2} - \frac{\varepsilon}{2}\right)^n + \binom{n}{n-2} \left(\frac{1}{2} - \frac{\varepsilon}{2}\right)^{n-2} \left(\frac{\varepsilon}{2}\right)^2 + \dots, \right. \\
&\quad \left. \binom{n}{n-1} \left(\frac{1}{2} - \frac{\varepsilon}{2}\right)^{n-1} \left(\frac{\varepsilon}{2}\right)^1 + \binom{n}{n-3} \left(\frac{1}{2} - \frac{\varepsilon}{2}\right)^{n-3} \left(\frac{\varepsilon}{2}\right)^3 + \dots \right\} \\
&= \sum_y \left(\binom{n}{n-1} \left(\frac{1}{2} - \frac{\varepsilon}{2}\right)^{n-1} \left(\frac{\varepsilon}{2}\right)^1 + \binom{n}{n-3} \left(\frac{1}{2} - \frac{\varepsilon}{2}\right)^{n-3} \left(\frac{\varepsilon}{2}\right)^3 + \dots \right) \\
&= \sum_{i=1}^{n/2} \binom{n}{n-(2i-1)} (1-\varepsilon)^{n-(2i-1)} \varepsilon^{2i-1}, \tag{19}
\end{aligned}$$

which is larger than ε for all $n > 1$, and shows that there exists a constant lower bound on the knowledge Eve can always obtain about the key bit by using this strategy. Furthermore, at the limit of large n , the non-uniformity of the bit $f(\mathbf{X})$ tends toward $1/2$ and Eve can have almost perfect knowledge about Alice's output bit, no matter the original error of the box. \square

4. Impossibility of Privacy Amplification by Any Hashing

In this section, we look at the case where Alice and Bob apply any function of their choice to their output bits. First we will show that by using the box partition \bar{w} defined in Section 3.2, Eve can gain the same knowledge for a given function, no matter what the input of Alice and Bob was. This property will make the argument simpler, as it will be sufficient to look at the non-uniformity of the bit $f(\mathbf{X})$ for the all-0 input.

Lemma 9. *The non-uniformity of the bit $f(\mathbf{X})$ conditioned on the box partition \bar{w} defined in Section 3.2 is independent of the values of \mathbf{u}, \mathbf{v} , i.e., $\delta_{\bar{w}}^f(\mathbf{u}, \mathbf{v}) = \delta_{\bar{w}}^f$.*

Proof. Let us first express the probability of the output \mathbf{x}, \mathbf{y} , given input \mathbf{u}, \mathbf{v} , as a function of the probabilities given the 0-input.

$$\begin{aligned}
P(\mathbf{xy}|\mathbf{uv}) &= \left(\frac{1}{2} - \frac{\varepsilon}{2}\right)^{\sum_i 1 \oplus x_i \oplus y_i \oplus u_i \cdot v_i} \cdot \left(\frac{\varepsilon}{2}\right)^{\sum_i x_i \oplus y_i \oplus u_i \cdot v_i} \\
&= P(\mathbf{xy}'|0\dots 0),
\end{aligned}$$

where we have again defined $y'_i = y_i \oplus u_i \cdot v_i$. Therefore,

$$\begin{aligned}
\delta_w^f(\mathbf{u}, \mathbf{v}) &= \sum_{\mathbf{y}} \min \left\{ \sum_{\mathbf{x}|f(\mathbf{x})=0} P(\mathbf{xy}|\mathbf{uv}), \sum_{\mathbf{x}|f(\mathbf{x})=1} P(\mathbf{xy}|\mathbf{uv}) \right\} \\
&= \sum_{\mathbf{y}'} \min \left\{ \sum_{\mathbf{x}|f(\mathbf{x})=0} P(\mathbf{xy}'|0\dots 0), \sum_{\mathbf{x}|f(\mathbf{x})=1} P(\mathbf{xy}'|0\dots 0) \right\} \\
&= \sum_{\mathbf{y}} \min \left\{ \sum_{\mathbf{x}|f(\mathbf{x})=0} P(\mathbf{xy}|0\dots 0), \sum_{\mathbf{x}|f(\mathbf{x})=1} P(\mathbf{xy}|0\dots 0) \right\} \\
&= \delta_w^f(0\dots 0, 0\dots 0) .
\end{aligned}$$

□

Hence, we only have to find a lower bound on the non-uniformity $\delta_w^f(0\dots 0, 0\dots 0)$, which we can explicitly write as

$$\begin{aligned}
\delta_w^f(0\dots 0, 0\dots 0) &= \sum_{\mathbf{y}} \min \left\{ \sum_{\mathbf{x}|f(\mathbf{x})=0} \left(\frac{1}{2} - \frac{\varepsilon}{2} \right)^{n-d_H(\mathbf{x},\mathbf{y})} \cdot \left(\frac{\varepsilon}{2} \right)^{d_H(\mathbf{x},\mathbf{y})}, \right. \\
&\quad \left. \sum_{\mathbf{x}|f(\mathbf{x})=1} \left(\frac{1}{2} - \frac{\varepsilon}{2} \right)^{n-d_H(\mathbf{x},\mathbf{y})} \cdot \left(\frac{\varepsilon}{2} \right)^{d_H(\mathbf{x},\mathbf{y})} \right\} .
\end{aligned}$$

Before we continue, we have to introduce some basic facts about correlations:

We will use the following expression for the *distance from uniform* of a random bit X :

$$\delta(P_X, P_U) = \max(P_X(0), P_X(1)) - \frac{1}{2} .$$

The *correlation* c_{XY} between two random bits X and Y is the probability for the two bits to be equal, minus the probability for the two bits to be different

$$c_{XY} = P(X = Y) - P(X \neq Y) .$$

Two equal random bits have correlation 1 and are called *completely correlated*, two random bits which are always different have correlation -1 and are called *completely anti-correlated*.

Let us further notice here the following: Assume Alice has a random bit-string \mathbf{X} to which she applies a public function f to obtain a single bit: $f : \mathbf{X} \rightarrow \{0, 1\}$. Bob has a random bit-string \mathbf{Y} which is correlated with \mathbf{X} and he would like to calculate a bit Z that is highly correlated with $f(\mathbf{X})$. Then the best achievable correlation is $c_{Zf(\mathbf{X})}^{\text{opt}} = 2\mathbb{E}_{\mathbf{y}}[\max(P(f(\mathbf{X}) = 0|Z = z), P(f(\mathbf{X}) = 1|Z = z))] - 1$, and it is reached by choosing Z to be 0 (respectively 1) if $f(\mathbf{X})$ is more likely to be 0 (1) given the information \mathbf{Y} .

Definition 6. Assume a random variable \mathbf{X} , which is mapped to a bit $f(\mathbf{X}) \in \{0, 1\}$, and a random variable \mathbf{Y} giving some information about the value of \mathbf{X} . The *maximum likelihood function* g of $f(\mathbf{X})$ given \mathbf{Y} is the function $g : \mathbf{Y} \rightarrow \{0, 1\}$ defined as

$$g(\mathbf{y}) = \begin{cases} 0 & \text{if } P(f(\mathbf{X}) = 0 | \mathbf{Y} = \mathbf{y}) \geq P(f(\mathbf{X}) = 1 | \mathbf{Y} = \mathbf{y}) \\ 1 & \text{if } P(f(\mathbf{X}) = 0 | \mathbf{Y} = \mathbf{y}) < P(f(\mathbf{X}) = 1 | \mathbf{Y} = \mathbf{y}) \end{cases}.$$

With these definitions, we can now show the key lemma for the derivation of our result. It states that Eve can always obtain knowledge proportional to the error in correlation between Alice's and Bob's key bit.

Lemma 10. *There exists a box partition w such that $\delta_w^f = 1/2 - 1/2 \cdot c_{f(\mathbf{X})g(\mathbf{Y})}$, where $f, g : \{0, 1\}^n \rightarrow \{0, 1\}$, and where g is the maximum likelihood function of $f(\mathbf{X})$ given \mathbf{Y} .*

Proof. It suffices to show that the box partition \bar{w} given in Section 3.2 (see (18)) reaches this bound:

$$\begin{aligned} \delta_{\bar{w}}^f &= \frac{1}{2^n} \sum_{\mathbf{y}} \min \left\{ \sum_{\mathbf{x}|f(\mathbf{x})=0} (1 - \varepsilon)^{n-d_H(\mathbf{x}, \mathbf{y})} \cdot \varepsilon^{d_H(\mathbf{x}, \mathbf{y})}, \sum_{\mathbf{x}|f(\mathbf{x})=1} (1 - \varepsilon)^{n-d_H(\mathbf{x}, \mathbf{y})} \cdot \varepsilon^{d_H(\mathbf{x}, \mathbf{y})} \right\} \\ &= 1 - \frac{1}{2^n} \sum_{\mathbf{y}} \max \left\{ \sum_{\mathbf{x}|f(\mathbf{x})=0} (1 - \varepsilon)^{n-d_H(\mathbf{x}, \mathbf{y})} \cdot \varepsilon^{d_H(\mathbf{x}, \mathbf{y})}, \sum_{\mathbf{x}|f(\mathbf{x})=1} (1 - \varepsilon)^{n-d_H(\mathbf{x}, \mathbf{y})} \cdot \varepsilon^{d_H(\mathbf{x}, \mathbf{y})} \right\} \\ &= 1 - \mathbb{E}_{\mathbf{y}} [\max(P(f(\mathbf{X}) = 0 | \mathbf{Y} = \mathbf{y}), P(f(\mathbf{X}) = 1 | \mathbf{Y} = \mathbf{y}))]. \end{aligned}$$

However, the last line is exactly equal to $1/2 - 1/2 \cdot c_{f(\mathbf{X})g(\mathbf{Y})}$, where g is the maximum likelihood function of $f(\mathbf{X})$ given \mathbf{Y} . \square

This means that unless Bob is able to create an output bit which is highly correlated with Alice's, the adversary can always obtain knowledge about the key bit. However, if Alice just applies the trivial function mapping all outputs to zero, then the correlation between Alice's and Bob's output bit could become 1, and this bound becomes trivial. We will now show that this does not help because in order to obtain a high correlation, Alice and Bob need to apply a biased hash function, and in that case the adversary can obtain high knowledge as well.

The following theorem, proven by Yang [25], shows the trade-off between randomness and correlation of two random bits.

Theorem 11 (Yang [25]). *Suppose that Alice and Bob share n uniformly random bits with correlation $1 - 2\varepsilon$. Then the maximal correlation that can be reached if Alice and Bob both locally apply a function f (and g , respectively) to their n original bits is $1 - 2\varepsilon(1 - 4\delta^2)$, where $\delta := \max(\delta(P_f(\mathbf{X}), P_U), \delta(P_g(\mathbf{Y}), P_U))$.*

Lemma 10 shows that if δ is small, then Eve's knowledge is high. We now need to see whether we can lower-bound Eve's knowledge for the case of large δ . For δ to be large, either $\delta(P_f(\mathbf{X}), P_U)$ or $\delta(P_g(\mathbf{Y}), P_U)$ needs to be large. Let us first show that if $\delta(P_f(\mathbf{X}), P_U)$ is large, then so is Eve's knowledge about $f(\mathbf{X})$. But this is easy, as the non-uniformity of the bit $f(\mathbf{X})$ is automatically also a lower-bound on the non-uniformity of $f(\mathbf{X})$ as seen from Eve's point of view; i.e., if the key bit is biased, then an adversary has *a priori* information about it. This is stated in Lemma 12.

Lemma 12. *There exists a box partition w such that the non-uniformity of the bit $f(\mathbf{X})$ is at least $\delta(P_{f(\mathbf{X})}, P_U)$, i.e., $\delta_w^f \geq \delta(P_{f(\mathbf{X})}, P_U)$.*

Proof. This bound can be obtained by the trivial box partition:

$$\delta_{no\ partition}^f(\mathbf{u}, \mathbf{v}) = \frac{1}{2} \cdot |P(f(\mathbf{X}) = 0|\mathbf{uv}) - P(f(\mathbf{X}) = 1|\mathbf{uv})| = \delta(P_{f(\mathbf{X})}, P_U) \quad (20)$$

□

We, therefore, found a second bound on the non-uniformity of the bit $f(\mathbf{X})$ given w : $\delta_{no\ partition}^f \geq \delta(P_{f(\mathbf{X})}, P_U)$. It remains to exclude the case that δ is large because $\delta(P_{f(\mathbf{X})}, P_U)$ is small and $\delta(P_{g(\mathbf{Y})}, P_U)$ is large.

Lemma 13. *There exists a box partition w such that the non-uniformity of the bit $f(\mathbf{X})$ is at least the absolute value of the difference between $\delta(P_{f(\mathbf{X})}, P_U)$ and $\delta(P_{g(\mathbf{Y})}, P_U)$, i.e., $\delta_w^f \geq |\delta(P_{g(\mathbf{Y})}, P_U) - \delta(P_{f(\mathbf{X})}, P_U)|$.*

Proof. It is enough to show that the box partition \bar{w} reaches this bound. Note that when $|\delta(P_{g(\mathbf{Y})}, P_U) - \delta(P_{f(\mathbf{X})}, P_U)|$ is large, then the correlation between the bits $f(\mathbf{X})$ and $g(\mathbf{Y})$ must be low:

$$\begin{aligned} c_{f(\mathbf{X})g(\mathbf{Y})} &= 2 \cdot P(f(\mathbf{X}) = g(\mathbf{Y})) - 1 \\ &\leq 2(1 - |\delta(P_{g(\mathbf{Y})}, P_U) - \delta(P_{f(\mathbf{X})}, P_U)|) - 1 \\ &= 1 - 2|\delta(P_{g(\mathbf{Y})}, P_U) - \delta(P_{f(\mathbf{X})}, P_U)|. \end{aligned}$$

Using Lemma 10, we can connect the correlation with the non-uniformity of $f(\mathbf{X})$ given \bar{w} :

$$|\delta(P_{g(\mathbf{Y})}, P_U) - \delta(P_{f(\mathbf{X})}, P_U)| \leq \frac{1}{2} - \frac{1}{2}c_{f(\mathbf{X})g(\mathbf{Y})} = \delta_{\bar{w}}^f.$$

□

Using Lemma 12 and 13, we can now connect the non-uniformity of the bit $f(\mathbf{X})$ with δ :

Lemma 14. *For every hash function f , there exists a box partition w such that $\delta_w^f \geq 1/2 \cdot \delta$, where $\delta := \max(\delta(P_{f(\mathbf{X})}, P_U), \delta(P_{g(\mathbf{Y})}, P_U))$ and g is the maximum likelihood function of $f(\mathbf{X})$ given \mathbf{Y} .*

Note that the box partition w can depend on the choice of hash function f because the adversary can delay the choice of w .

Proof. Lemmas 12 and 13 show that

$$\begin{aligned} \delta_{no\ partition}^f &\geq \delta(P_{f(\mathbf{X})}, P_U) \\ \delta_{\bar{w}}^f &\geq \delta(P_{g(\mathbf{Y})}, P_U) - \delta(P_{f(\mathbf{X})}, P_U). \end{aligned}$$

This implies directly that there exists a suitable box partition (either \bar{w} or the trivial one) such that $\delta_w^f \geq 1/2 \cdot \max(\delta(P_{g(\mathbf{Y})}, P_U), \delta(P_{f(\mathbf{X})}, P_U)) = 1/2 \cdot \delta$. □

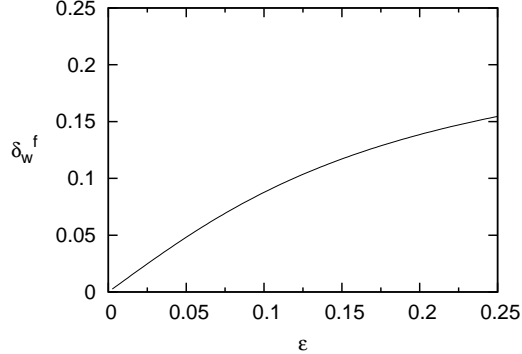

Figure 5: The lower bound on the non-uniformity of the final bit as function of the error of the boxes ϵ .

Now we can put all the previous lemmas together to obtain a general lower bound on the adversary's knowledge.

Theorem 15. *For every hash function f , there exists a box partition w such that the non-uniformity of the bit $f(\mathbf{X})$ given w is at least $\frac{-1+\sqrt{1+64\epsilon^2}}{32\epsilon}$.*

Proof. Lemmas 10 and 14 show that

$$\begin{aligned} \delta_w^f &\geq 1/2 \cdot \delta \\ \delta_w^f &\geq 1/2 - 1/2 \cdot c_{f(\mathbf{X}),g(\mathbf{Y})} \geq \epsilon(1 - 4\delta^2), \end{aligned}$$

where $\delta := \max(\delta(P_{f(\mathbf{X})}, P_U), \delta(P_{g(\mathbf{Y})}, P_U))$. Therefore, $\delta_w^f \geq \max(1/2 \cdot \delta, \epsilon(1 - 4\delta^2))$, which takes its lowest value for $1/2 \cdot \delta = \epsilon(1 - 4\delta^2)$, namely $1/2 \cdot \delta = \frac{-1+\sqrt{1+64\epsilon^2}}{32\epsilon}$. \square

Note that for small ϵ , this lower bound actually gives a value of δ_w^f close to 2ϵ ; for ϵ close to 0.25, it is still larger than $\epsilon/2$. We obtain a constant lower bound (see Fig. 5) depending only on the error of the individual boxes ϵ but not on the number of boxes n . This shows that the non-uniformity of the bit $f(\mathbf{X})$, given w , can never become negligible in the number n of boxes, and, therefore, privacy amplification of relativistic cryptography is impossible.

5. Concluding Remarks

Cryptographic security can be proven only if certain assumptions are made. This can be a limitation on the adversary's computing power, memory space, or accessible information. Another example is quantum cryptography, which is based on the accuracy and completeness of the quantum-physical description of nature. Although this theory has been tested by a great number of experiments, it may be attractive to have an alternative, and to base cryptographic security on the fact that quantum *or* relativity theory is correct. An additional advantage — and more important in practice — of such

“non-signaling” schemes, first proposed by Barrett, Hardy, and Kent [4], over traditional quantum cryptography, going back to Bennett and Brassard [7] as well as Ekert [14], is that the security is *device-independent*: Alice and Bob do not have to trust the manufacturer of the devices or, more precisely, in the fact that they are actually operating on the quantum systems they are supposed to be. They can derive the security directly from the correlations in their classical data.

Unfortunately, it appears that such security cannot be achieved this way unless the physical systems are noiseless and the communication complexity is exponential in any reasonable security parameter (as it is the case for Barrett *et al.*'s protocol). Indeed, we have shown that one of the key ingredients for obtaining unconditional classical as well as quantum key agreement efficiently, namely privacy amplification, fails here. In this light, it may be even more surprising that general quantum privacy amplification is possible [16]. In particular, note that our impossibility result holds even for the case of collective attacks, for which the possibility of device-independent security has been shown [1]. An obvious open question is whether privacy amplification could be made possible by enforcing a time-like ordering between the n systems and therefore imposing a non-signaling condition in one direction. Physically, this would be easily realizable by measuring several quantum systems one after another.

Acknowledgments: We thank two anonymous referees for their valuable comments. This work is supported by the Swiss National Science Foundation.

References

- [1] A. Acín, N. Brunner, N. Gisin, S. Massar, S. Pironio, and V. Scarani. Device-independent security of quantum cryptography against collective attacks. *Physical Review Letters*, 98:230501, 2007.
- [2] A. Acín, N. Gisin, and Ll. Masanes. From Bell's theorem to secure quantum key distribution. *Physical Review Letters*, 97:120405, 2006.
- [3] A. Acín, S. Massar, and S. Pironio. Efficient quantum key distribution secure against no-signalling eavesdroppers. *New Journal of Physics*, 8(8):126, 2006.
- [4] J. Barrett, L. Hardy, and A. Kent. No signalling and quantum key distribution. *Physical Review Letters*, 95:010503, 2005.
- [5] J. S. Bell. On the Einstein-Podolsky-Rosen paradox. *Physics*, 1:195–200, 1964.
- [6] C. Bennett, G. Brassard, C. Crépeau, and U. Maurer. Generalized privacy amplification. In *Proc. 1994 IEEE International Symposium on Information Theory (Abstracts)*, page 350, 1994.
- [7] C. H. Bennett and G. Brassard. Quantum cryptography: public key distribution and coin tossing. In *Proceedings of International Conference on Computers, Systems and Signal Processing*, 1984.
- [8] Ch. Bennett, G. Brassard, and J.-M. Robert. Privacy amplification by public discussion. *SIAM Journal on Computing*, 17(2):210–229, 1988.
- [9] E. Biham, M. Boyer, G. Brassard, J. van de Graaf, and T. Mor. Security of quantum key distribution against all collective attacks. *Algorithmica*, 34(4):372–388, 2008.
- [10] E. Biham and T. Mor. Bounds on information and the security of quantum cryptography. *Physical Review Letters*, 79(20):4034–4037, 1997.
- [11] E. Biham and T. Mor. Security of quantum cryptography against collective attacks. *Physical Review Letters*, 78(11):2256–2259, 1997.
- [12] J. F. Clauser, M. A. Horne, A. Shimony, and R. A. Holt. Proposed experiment to test local hidden-variable theories. *Physical Review Letters*, 23(15):880–884, 1969.
- [13] A. Einstein, B. Podolsky, and N. Rosen. Can quantum-mechanical description of physical reality be considered complete? *Physical Review*, 47:777–780, 1935.
- [14] A. K. Ekert. Quantum cryptography based on Bell's theorem. *Physical Review Letters*, 67(6):661–663, 1991.

- [15] R. Impagliazzo, L. Levin, and M. Luby. Pseudo-random generation from one-way functions. In *STOC '89: Proceedings of the twenty-first annual ACM symposium on Theory of computing*, pages 12–24, 1989.
- [16] R. König, U. Maurer, and R. Renner. On the power of quantum memory. *IEEE Transactions on Information Theory*, 51(7):2391–2401, 2005.
- [17] Ll. Masanes. Universally composable privacy amplification from causality constraints. *Physical Review Letters*, 102(14):140501, 2009.
- [18] Ll. Masanes, R. Renner, A. Winter, J. Barrett, and M. Christandl. Security of key distribution from causality constraints, 2008, quant-ph/0606049v2.
- [19] Ll. Masanes and A. Winter. Unconditional security of key distribution from causality constraints, 2006, quant-ph/0606049v1.
- [20] S. Popescu and D. Rohrlich. Quantum nonlocality as an axiom. *Foundations of Physics*, 24(3):379–385, 1994.
- [21] R. Renner. *Security of quantum key distribution*. PhD thesis, Swiss Federal Institute of Technology (ETH) Zurich, 2005. available at <http://arxiv.org/abs/quant-ph/0512258>.
- [22] V. Scarani, N. Gisin, N. Brunner, Ll. Masanes, S. Pino, and A. Acín. Secrecy extraction from no-signalling correlations. *Physical Review A*, 74(4):042339, 2006.
- [23] B. M. Terhal. Is entanglement monogamous? *IBM Journal of Research and Development*, 48(1):71–78, 2004.
- [24] S. Wolf. Reducing oblivious string transfer to universal oblivious transfer. In *Proceedings of ISIT 2000*, page 311, 2000.
- [25] K. Yang. On the (im)possibility of non-interactive correlation distillation. *Theoretical Computer Science*, 382(2):157–166, 2007.